

CATALOGUE & TECHNICAL GUIDE 2015



TURNING

Alphanumeric index	Tools.....	4-6	
	Inserts	7-8	
ISO Turning	Code keys	Toolholders.....	10-17
		Inserts	18-20
	Principles	Insert shape, principles.....	21
		Toolholders, insert clamping principles	22
		Secolor® principles	23
		Chipbreaker principles.....	24-25
		Insert grade principles	26
	Product guidance	Jetstream Tooling®.....	27-29
		Seco-Capto™.....	30
		Chipbreakers.....	31-36
		Insert grades	37-40
		High Feed inserts	41-42
		High Feed inserts, chipbreakers	43-44
		High Feed inserts, guidelines	45-46
		Cutting data recommendations, SMG v2	47-54
		Small diameter boring, cutting data	55
		Railway wheel machining	56-57
		Railway wheel machining, cutting data	58
		Troubleshooting.....	60-61
		Insert wear and failure modes.....	62-65
		Secomax PCBN, Principles and guidance.....	66-70
		Secomax PCBN, Grades.....	71-74
		Secomax PCBN, Cutting data recommendations SMG v2	75-79
		Secomax PCBN, Troubleshooting.....	80
		Secomax PCD, Principles and grades.....	81
		Secomax PCD, Cutting data recommendations SMG v2.....	82-83
		Secomax PCD, Troubleshooting	84
		Secomax Ceramics, principles	85-86
		Secomax Ceramics, grades	87
		Secomax Ceramics, Cutting data recommendations SMG v2	88-89
		Secomax Ceramics, Troubleshooting.....	90
	Application overview	Toolholders, external	91-99
		Toolholders, internal	100-105
		Toolholders, for boring.....	106
		Cartridges.....	107
	Toolholders	External Jetstream Tooling®, Seco-Capto™	109-118
		External Jetstream Tooling®.....	119-129
		External Seco-Capto™.....	130-177
		External.....	178-246
		Internal Seco-Capto™.....	247-268
		Internal.....	269-303
		Steadyline®, damping holders for GL heads	304-305
		Steadyline®, GL heads.....	306-313
		MTM, Seco-Capto™.....	314-320
		Boring.....	321-322
		Cartridges.....	323-328
		Cassettes for railway wheel machining.....	329-333
	Adapters	Seco-Capto™, adapters for shank tools.....	334-338
		Seco-Capto™, adapters for solid boring bars	339-342

ISO Turning

MDT

Mini shaft

Grooving

Parting-off

X4

Clamping units

Accessories and Spare parts

SMG

ISO Turning	Inserts	Cemented carbide and Cermet	343-399
		Secomax PCBN	400-431
		Secomax PCD	432-435
		Secomax Ceramics	436-437
MDT		General information	439
	Application overview	Toolholders, external, modular blades	440-443
		Toolholders, axial, modular blades	444-447, 450
		Toolholders, internal	448-449
		Toolholders for modular blades	450
		Toolholders, MTM	451
	Code key	Toolholders	452-456
		Inserts	457-458
	Product guidance	Toolholders	459-461
		Inserts and grades	462-469
		Application technique	470-476
		Cutting data	477-486
		Troubleshooting	487-488
	Toolholders	External Jetstream Tooling®, Seco-Capto™	489-495
		External axial Jetstream Tooling®, Seco-Capto™	496-516
		External Jetstream Tooling®	517-522
		External axial Jetstream Tooling®	523-532
		External Seco-Capto™	533-534
		External	535-542
		External axial	543-548
		Internal Seco-Capto™	549-555
		Internal	556-559
		MTM, Jetstream Tooling®, Seco-Capto™	560
		Holders for modular blades, blades	561-572
	Inserts	Cemented carbide	573-591
		Secomax PCBN	592-594
Mini shaft		General information	595
		Code key, Toolholders and Inserts	596-598
		Product guidance and Cutting data	599-600
		Toolholders	601
		Inserts	602-609
Grooving		Code key, Toolholders and Inserts	610-611
		Product guidance	612-615
		Cutting data	616
		Toolholders MTM, Seco-Capto™	617
		Toolholders external	618-620
		Toolholders, internal	621-622
		Inserts	623-632
Parting-off, 150.10		Code key, Toolholders and Inserts	633
		Product guidance	634-639
		Cutting data	640-643
		Toolholders, Seco-Capto™	644-645
		Toolholders and blades, Jetstream Tooling® Duo blades	646-648
		Inserts	649-650

X4	General information	652
	Code key, Toolholders and inserts	653-655
	Product guidance	656-657
	Cutting data	658-660
	Toolholders, external Seco-Capto™, Jetstream Tooling® Duo	661
	Toolholders, external, Jetstream Tooling® Duo	662
	Toolholders, external	663
	Blades	664
	Inserts, cemented carbide	665-668
	Inserts, Secomax PCBN	669
Clamping units	Product guidance	670-673
	Clamping units	674-678
Accessories and Spare parts	Spare parts for Seco-Capto™ Clamping units	679-683
	Accessories for Jetstream Tooling®	684
	Accessories for Seco-Capto™	685
	Screw torque keys and Torque values	686-687
SMG	Workpiece materials – Classification, SMG v2	688-699
	Declaration of conformity	700-702

ISO Turning

MDT

Mini shaft

Grooving

Parting-off

X4

Clamping units

Accessories and Spare parts

SMG

1	
131-	342
132N-	341
150.10	646-648
A	
A.-CGER/L	556
A.-CGFR/L	556-557
A.-CGGR/L	557-558
A.-CGHR/L	556, 559
A.-CGIR/L	557
A.-CGJR/L	556, 559
A.-DDUNR/L...C	284
A.-DWLNR/L...C	303
A.-FR/L	564
A.-PCLNR/L	275-276
A.-PDQNR/L	286
A.-PDUNR/L	282
A.-PDYNR/L	285
A.-PTFNR/L	294-295
A.-PVLNR/L	299
A.-PVPNR/L	299
A.-PWLNR/L	302
A.-SCFCR/L	269
A.-SCFCR/L...R	269
A.-SCFDR/L	273
A.-SCLCR/L	271-272
A.-SCLCR/L...R	271-272
A.-SCLDR/L	273
A.-SDQCR/L	279
A.-SDQCR/L...R	279
A.-SDQNR/L	286
A.-SDUCR/L	280
A.-SDUCR/L...R	280
A.-SDUNR/L	281
A.-SDYNR/L	285
A.-SGXN	601
A.-SGXN...R	601
A.-STFCR/L	291
A.-STFDR/L	292
A.-STLDR/L	292
A.-SVQBR/L	297
A.-SVUBR/L	297
A.-SWLCR/L	300
C	
C.-131	339-340
C.-150.10	644
C.-ASHA	334
C.-ASHA...M	334
C.-ASHR/L	335-336, 338
C.-ASHS	337
C.-CCLNR/L	138
C.-CDIR/L...JET	560
C.-CER/L	617
C.-CER/L...HD	617
C.-CFIR/L	533-534
C.-CFIR/L...JET	489-490, 496-502
C.-CFMR/L...JET	491-492
C.-CFOR/L...JET	493-494, 503-516
C.-CFZR/L...RBJET	495
C.-CGER/L	549-550
C.-CGFR/L	549-552
C.-CGGR/L	551-554
C.-CGHR/L	549-550, 555
C.-CGIR/L	551-552
C.-CGJR/L	549-550, 555
C.-CRSNR/L	148
C.-CSDNN	161
C.-CSKNR/L	162
C.-CSRNR/L	163
C.-CTJNR/L	169
C.-CTUNR/L	262
C.-D...GL	304
C.-DCKNR/L...M	131-132
C.-DCLNR/L	135
C.-DCLNR/L...M	133-134
C.-DCMNN...M	315
C.-DCRNR/L	137
C.-DCRNR/L...M	136
C.-DDJNR/L	141
C.-DDJNR/L...M	141
C.-DDMNR/L...M	316
C.-DDNN...M	143
C.-DDUNR/L	142
C.-DRSNR/L...M	149
C.-DSDNN	160
C.-DSDNN...M	160
C.-DSKNR/L	153
C.-DSKNR/L...M	151-152
C.-DSRNR/L	156
C.-DSRNR/L...M	154-155
C.-DSSNR/L	159
C.-DSSNR/L...M	157-158
C.-DTFNR/L...M	168
C.-DTGNR/L...M	167
C.-DTJNR/L...M	166
C.-DVJNR/L	173
C.-DVMNL...M	319
C.-DWLNR/L	176
C.-FL-V21	561, 563
C.-FR-V21	561, 563
C.-GL-V21	561
C.-GR-V21	561
C.-L150.10	645
C.-LC2030...M	676-677
C.-LC2040	676-677
C.-LC2050	676-677
C.-LC2060	676-677
C.-LC2085	674
C.-LC2085...M	674
C.-LC2090	678
C.-LC2090...M	678
C.-MVUNR/L	265
C.-NC2000	675
C.-NC3000	675
C.-PCLNR/L	250-251
C.-PCLNR/L...JETL	110
C.-PDJNR/L...JETL	112
C.-PDQNR/L	257
C.-PDUNR/L	255-256
C.-PSSNR/L...JETL	114
C.-PTFNR/L...W	261
C.-PTJNR/L...JETL	115
C.-PVJNR/L	174

C.-PVJNR/L...JETL	117	CFMR/L...JET	519
C.-PVUNR/L	265	CFNN	571
C.-PWLNN	320	CFON	572
C.-PWLNR/L	177, 267-268	CFOR/L	539-540
C.-PWLNR/L...JETL	118	CFOR/L...JET	520, 527-532
C.-R/L150.10	645	CFPR/L	539
C.-R/LC2030...M	676-677	CFSR/L	540-541
C.-R/LC2040	676-677	CFSR/L...JET	521
C.-R/LC2050	676-677	CFTR/L	539
C.-R/LC2060	676-677	CFTR/L.ITX	570
C.-R/LC2085	674	CFXR/L.ITX	570
C.-R/LC2085...M	674	CFZR/L	542
C.-R/LC2090	678	CFZR/L...JET	522
C.-R/LC2090...M	678	CFZR/L.ITX	570
C.-SCLCR/L	130, 247-249	CGIR/L	546-548
C.-SCLCR/L...JET	109	CNR/L...A	622
C.-SCMCN	314	CNR/L...DA	622
C.-SDJCR/L	139	CNR/L...AHD	622
C.-SDJCR/L...JET	111	CRDNN	206
C.-SDNCN	140	CRSNR/L	206
C.-SDQNR/L	257	CSBNR/L	209
C.-SDUCR/L	252-253	CSDNN	210
C.-SDUCR/L...X	254	CSKNR/L	210
C.-SDUNR/L	256	CSNR/L	209
C.-SR/L-V21	561	CSSNR/L	211
C.-SRDCN	144-145, 317	CTFNR/L	232
C.-SRDCN...A	145	CTGNR/L...PL	231
C.-SRSCR/L	146-147	CTJNR/L	232
C.-SRSCR/L...JET	113	CT-PLANR/L	330
C.-SR-V21	561	CT-PLFNR/L	331
C.-SSKCR/L	258	CT-PSANR/L	332
C.-SSRCR/L	150	CT-PSFNR/L	333
C.-STFCR/L	259-260	CVVNN	237
C.-STGCR/L	164	D	
C.-STJCR/L	165	D.-GL	305
C.-SVHBR/L	170	DCBNR/L...M	183
C.-SVJBR/L	171	DCKNR/L...M	184
C.-SVJBR/L...JET	116	DCLNR/L...M	185-186
C.-SVMBR/L	318	DDHNR/L	196
C.-SVQBR/L	263-264	DDJNR/L	197
C.-SVVBN	172	DDJNR/L...C	201
C.-SWLCR/L	175, 266	DDJNR/L...M	197
C.-X4FR/L...JET	661	DDNN...C	201
CCBNR/L	191	DRSNR/L...M	207
CCLNR/L	191	DSBNR/L...C	222
CDJNR/L	200	DSBNR/L...M	212
CDNNN	200	DSDNN...M	213
CEAR/L...D	620	DSKNR/L...M	214
CEAR/L...HD	620	DSSNR/L...C	222
CEAR/L...QHD	620	DSSNR/L...M	215-216
CEAR/L...QHD	620	DTFNR/L...M	225
CER/L...D	618	DTGNR/L...M	226
CER/L...QHD	618-619	DVJNR/L	238
CFHN	571	DVJNR/L...C	240
CFIN	571	DVNNN...C	240
CFIR/L	535-536, 543-545	DVPNR/L	239
CFIR/L...JET	517-518, 523-526	DWLNR/L	242
CFJN	571	DWLNR/L...C	245
CFKN	571-572	E	
CFLN	571	E...SCFCR/L...R	270
CFMN	572	E...SGXN	601
CFMR/L	537-538	E...SGXN...R	601

F			
FR/L	562		
G			
GL.-CRSNR/L	311		
GL.-CTUNR/L	312		
GL.-DCLNR/L	308		
GL.-DDUNR/L	310		
GL.-DWLNR/L	313		
GL.-SCLCR/L	306		
GL.-SDUCR/L	309		
GL.-STFCR/L	307		
GR/L	562		
M			
MCBNR/L	187		
MCLNR/L	188		
MSBNR/L	217		
MSRNR	218		
MWLNR/L	243		
P			
PCBNR/L	190		
PCBNR/L...JETL	121		
PCLNR/L	189		
PCLNR/L...JETL	120		
PCLNR/L...JETLB	120		
PDJNR/L	198		
PDJNR/L...JETL	123		
PDJNR/L...JETLB	123		
PDNNR/L	199		
PLBNR/L	246		
PRDCN	205		
PSBNR/L	219		
PSDNN	221		
PSKNR/L	221		
PSSNR/L	220		
PSSNR/L...JETL	125		
PTBNR/L	227		
PTGNR/L	228		
PTGNR/L...A	228		
PTJNR/L	229		
PTJNR/L...JETL	126		
PTNNR/L	227, 230		
PVJNR/L...JETL	128		
PWLNR/L	244		
PWLNR/L...JETL	129		
R			
R/L150.10	646-647		
R/L175.32	329		
S			
S.-CCLNR/L	278		
S.-CRSNR/L	287		
S.-CSKNR/L	289		
S.-CTUNR/L	296		
S.-MCLNR/L	274		
S.-MSKNR/L	288		
S.-MTFNR/L	293		
S.-MVLNR/L	298		
S.-MVPNR/L	298		
S.-MVYNR/L	298		
S.-MWLNR/L	301		
S.-PCLNR/L	277		
S.-PDUNR/L	283		
S.-PSKNR/L	290		
S.-SCACR/L	322		
S.-SCDCR/L	322		
S.-SCECR/L	322		
SCACR/L	178, 321		
SCBCR/L	179		
SCDCR/L	180		
SCECL	321		
SCFCR/L	180, 323		
SCGCR/L	182, 324		
SCLCR/L	181, 323		
SCLCR/L...JET	119		
SCLCR/L...JETB	119		
SCRCR/L	325		
SCSCR/L	324		
SCTCR/L	325		
SCWCR/L	323		
SDACR/L	194		
SDHCR/L	192		
SDJCR/L	193		
SDJCR/L...JET	122		
SDJCR/L...JETB	122		
SDNCN	195		
SFN	571		
SL16	342		
SNR/L	621		
SR/L...V21	562		
SRDCN	204		
SRSCR/L	203		
SRSCR/L...JET	124		
SSDCN	208		
SSKCR/L	326		
STFCR/L	223, 327		
STGCL	328		
STGCR/L	223, 328		
STJCR/L	224		
STRCL	328		
STRCR/L	328		
STSCCL	327		
STSCR/L	327		
STTCL	328		
STTCR/L	328		
STWCR/L	327		
SVABR/L	234		
SVJBR/L	233		
SVJBR/L...JET	127		
SVJCR/L	234		
SVLBR/L	235		
SVVBN	236		
SWLCR/L	241		
T			
TRAOR/L	202		
TRDON	202		
V			
V21-CHR/L	567, 569		
V21-CIR/L	565, 567, 569		
V21-CJR/L	566, 568		
V21-CKR/L	566, 568		
V21-CMR/L	565, 567, 569		
V21-COR/L	566, 568		
X			
X4FR/L	663		
X4FR/L...JET	662		
X4FR/L.ITX	664		

1			
10EAR/L			
..FA	625	
10ER			
..D76	627	
..FD	626	
..FG	624	
..R	628	
12EAR/L			
..FD	625	
12ER			
..FD	626	
14EAR/L			
..AX	630	
..FA	625	
14ER			
..D76	627	
..DY	631	
..FG	624	
..R	628	
..ST	629	
150.10	649-650	
2			
20EAR/L			
..FA	625	
20EAR			
..AX	630	
20ER			
..D76	627	
..DY	631	
..FG	624	
..R	628	
..ST	629	
26ER			
..FG	624	
..R	628	
..ST	629	
9			
9NR/L			
..FG	623	
C			
CCGT	343, 431	
CCGW	400	
CCGX	344	
CCMT	345-347	
CCMW	401, 432	
CDCB	348	
CNGA	402	
CNGG	348	
CNGM	431	
CNGN	436	
CNMA	349	
CNMG	350-353	
CNMM	354-355	
CNMN	403	
D			
DCGT	356	
DCGW	404	
DCMT	357-358	
DCMW	405, 433	
DCMX	359	
DNGA	406	
DNGG	359	
DNGM	359	
DNGN	407	
DNMA	360, 407	
DNMG	361-363	
DNMN	408	
DNMU	364	
DNMX	365	
L			
LCEX	602-609	
LCGA	576	
LCGF	574, 584-586	
LCGN	586-594	
LCMF	573, 575, 577-581	
LCMR	582-583	
LNMX	366-367	
LPGN	632	
R			
RCGN	433	
RCGS	368, 408	
RCGX	436	
RCMT	369	
RCMX	370	
RNGN	409-410, 434, 437	
RNMA	371	
RNMG	371	
RNMN	411	
RPGX	437	
S			
SCGW	412	
SCMN	412	
SCMT	372-373	
SNGA	413	
SNGF	414	
SNGN	414-415	
SNMA	374, 416	
SNMG	375-376	
SNMM	377-378	
SNMN	417	
SNMX	379	
SNUN	379	
SPGW	418	
T			
TCGN	418	
TCGT	380	
TCGW	419	
TCGX	381	
TCMT	382	
TCMW	434	
TCMX	383	
TDAB	383	
TDCH	384	
TNGA	420	
TNGN	421-422	
TNGX	423	
TNMA	385	
TNMG	385-389	
TNMN	424	
TNMX	390, 425	
TPGN	425, 435	

V

VBGT.....	390
VBGW.....	426
VBMT.....	391
VBMW.....	435
VCGR.....	392
VCGT.....	392
VNGA.....	427
VNGG.....	393
VNMA.....	428
VNMG.....	394
VNMU.....	394

W

WCMT.....	395
WNGA.....	429
WNGG.....	395
WNMA.....	396, 430
WNMG.....	397-399

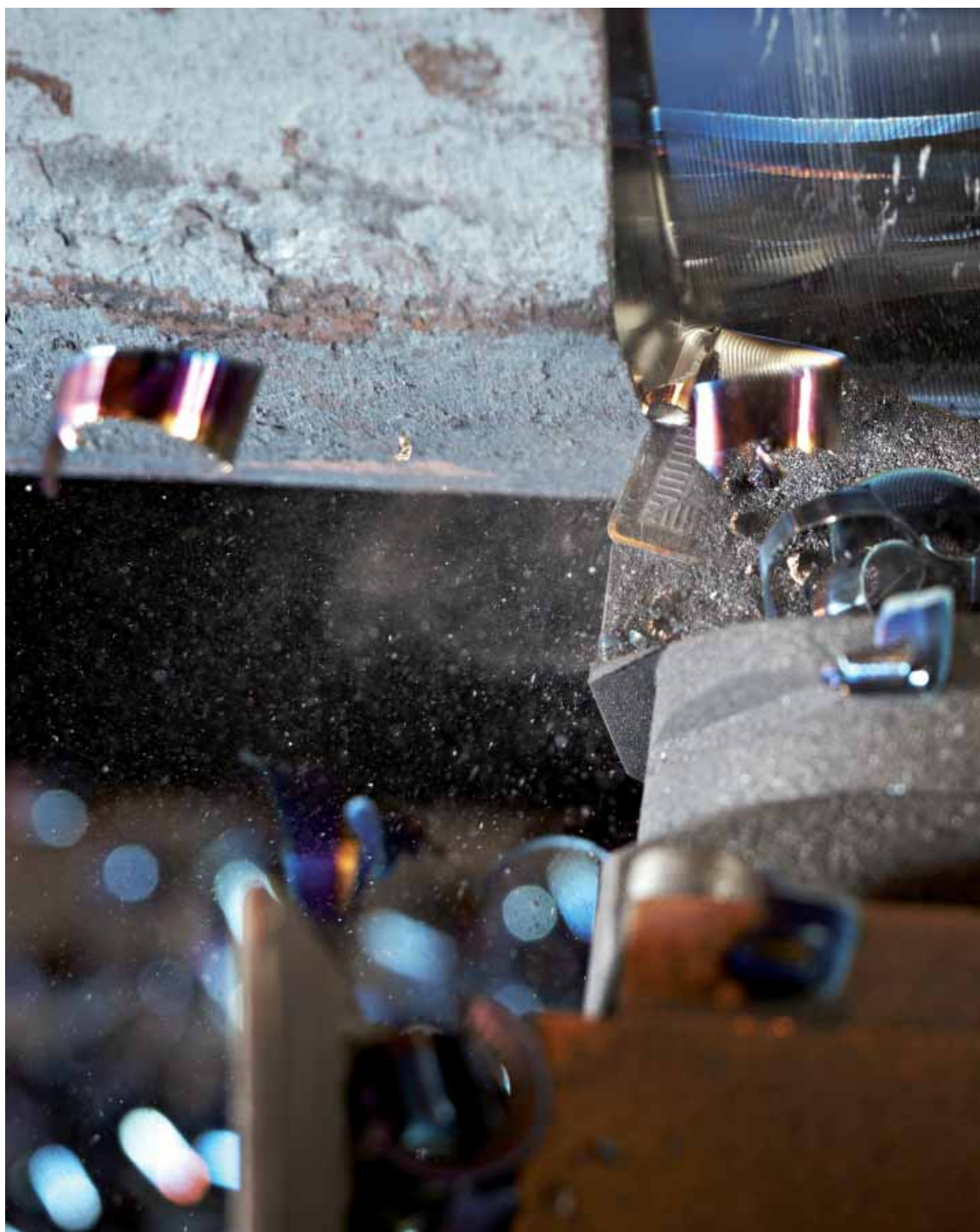

External toolholders

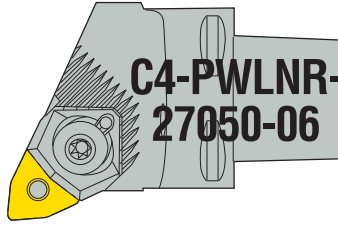

C4	-	P	W	L	N	R	-	27	050	-	06	-	
1		2	3	4	5	6		7	8		9		10

1. Seco-Capto™ size

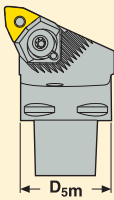

C3 = 32 mm
 C4 = 40 mm
 C5 = 50 mm
 C6 = 63 mm
 C8 = 80 mm

2. Insert clamping

D

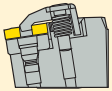

Clamp/inserts with centre hole

P



Pin/Wedge or Lever

M

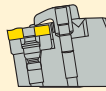

Pin/Clamp

S

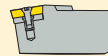

Screw

C

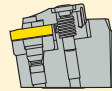

Clamp

3. Insert shape

A



B



C



D



E



H



K



L



M



O



P



R



S



T



V



W



4. Tool type

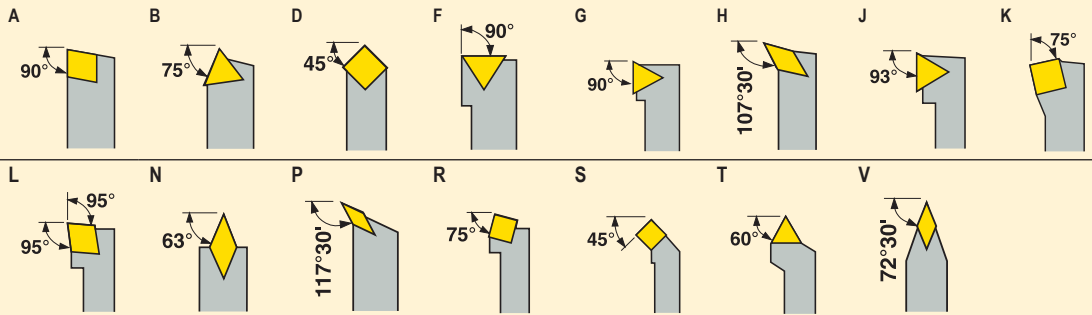

5. Insert side clearance angle

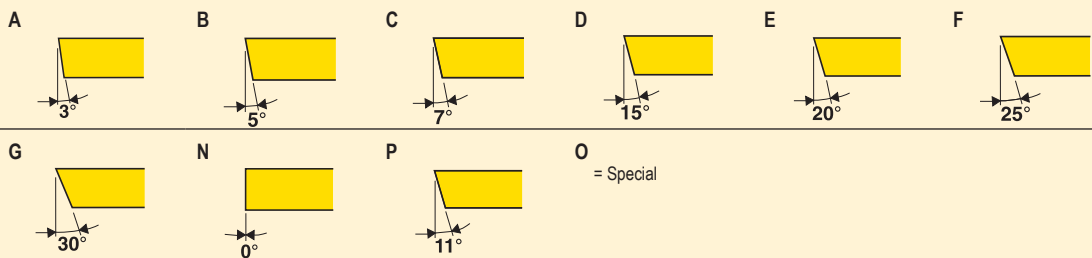

6. Cutting direction

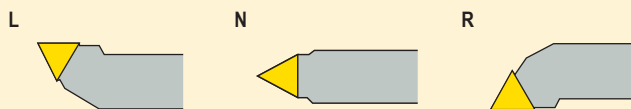

7. f₁-dimension

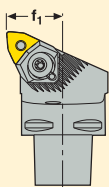

22 = 22 mm
 27 = 27 mm
 35 = 35 mm
 45 = 45 mm
 etc

8. l₁-dimension

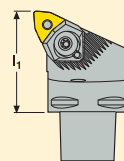

040 = 40 mm
 042 = 42 mm
 044 = 44 mm
 050 = 50 mm
 060 = 60 mm
 etc

9. Cutting edge length

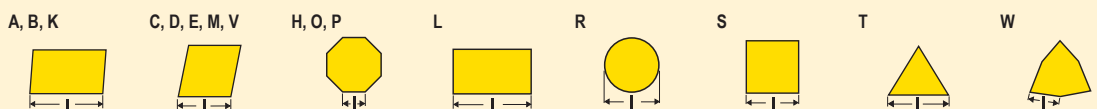

10. Internal designation

JET = Jetstream Tooling®
 JETL = Jetstream Tooling® with P-lever clamp

JETB = Jetstream Tooling® with inlet on backend of shank
 JETLB = Jetstream Tooling® with P-lever clamp and inlet on backend of shank

Internal toolholders and GL heads

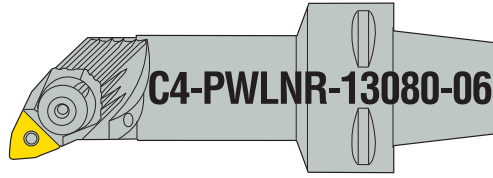

C4	-	P	W	L	N	R	-	13	080	-	06	-	
1		2	3	4	5	6		7	8		9		10

1. Seco-Capto size™

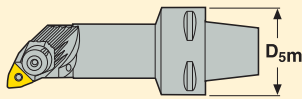

C3 = 32 mm
 C4 = 40 mm
 C5 = 50 mm
 C6 = 63 mm
 C8 = 80 mm

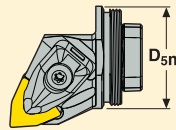

GL32 = 32 mm
 GL40 = 40 mm
 GL50 = 50 mm

2. Insert clamping

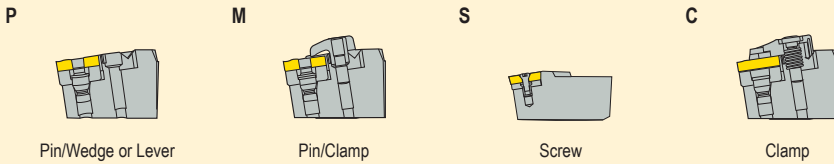

3. Insert shape

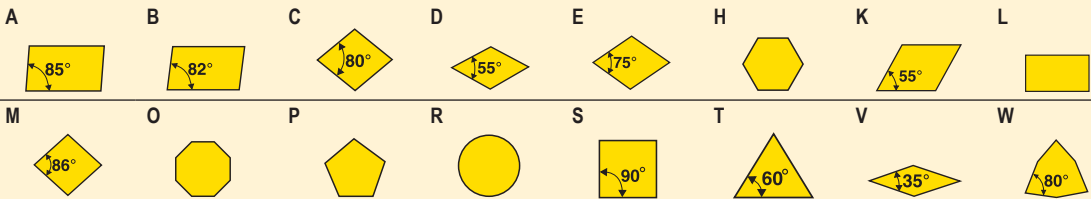

4. Tool type

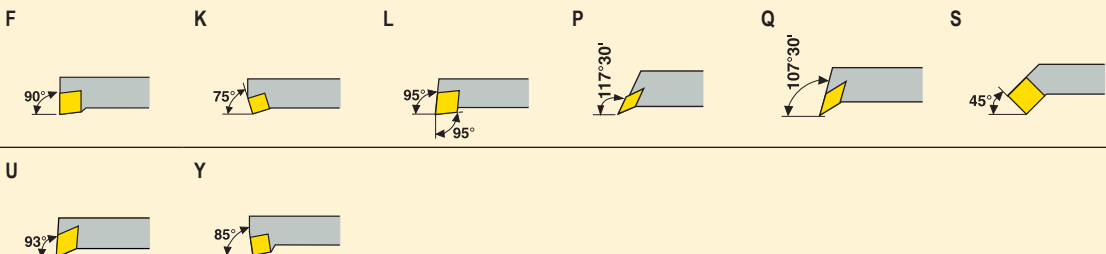

5. Insert side clearance angle

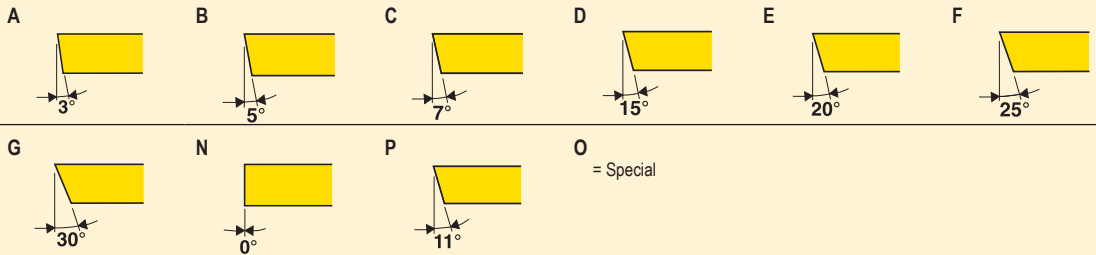

6. Cutting direction

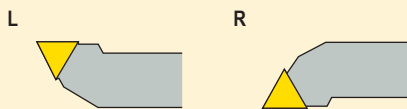

7. f_1 -dimension

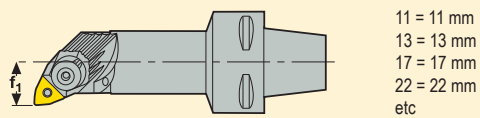

8. l_1 -dimension

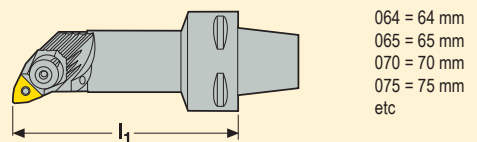

9. Cutting edge length

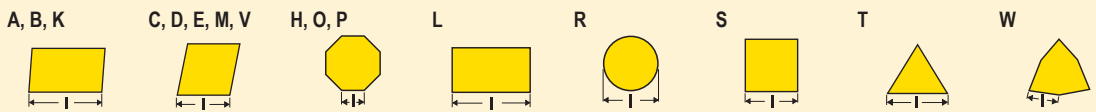

10. Internal designation

External toolholders



P	W	L	N	R	25	25	M	06	
1	2	3	4	5	6	7	8	9	10

1. Insert clamping

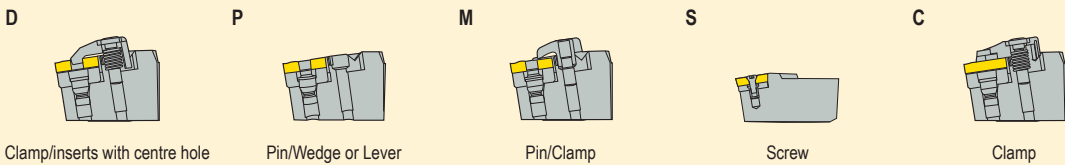

2. Insert shape

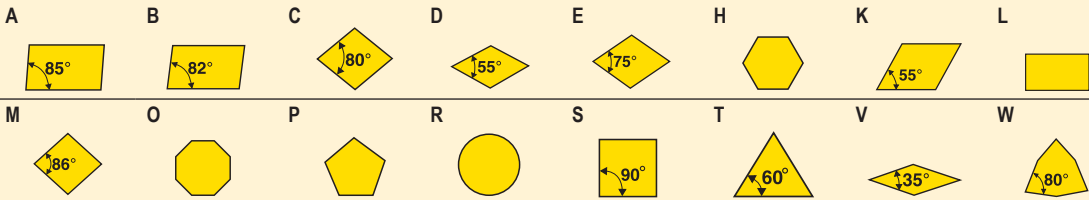

3. Tool type

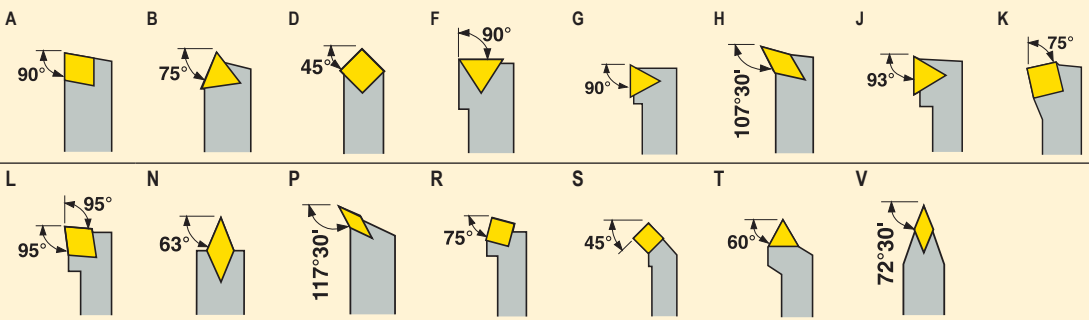

4. Insert side clearance angle

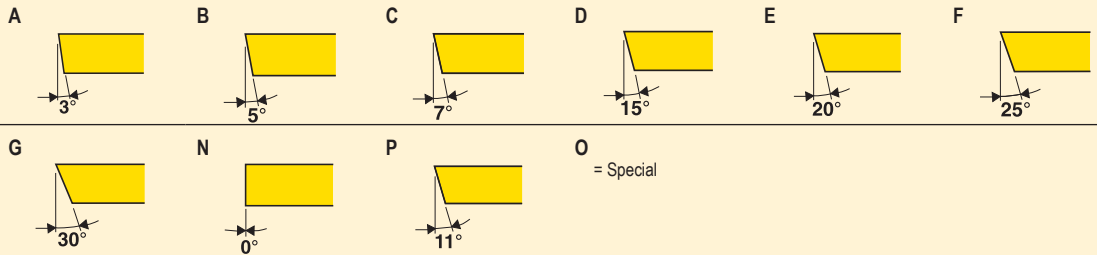

5. Cutting direction

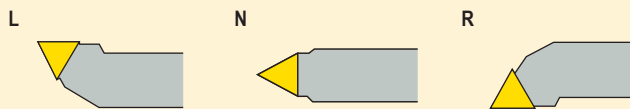

6. Shank height

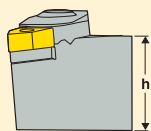

12 = 12 mm
25 = 25 mm
32 = 32 mm
etc

7. Shank width

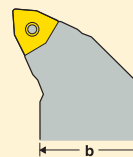

12 = 12 mm
25 = 25 mm
32 = 32 mm
etc

8. Tool length

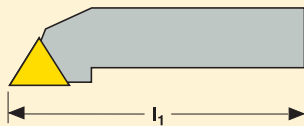

A = 32 mm
C = 50 mm
D = 60 mm
E = 70 mm
F = 80 mm

H = 100 mm
K = 125 mm
M = 150 mm
P = 170 mm
R = 200 mm

S = 250 mm
T = 300 mm
V = 400 mm

Standard length as above

9. Cutting edge length

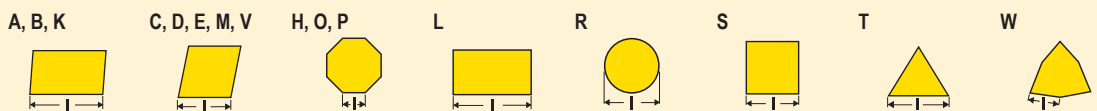

10. Internal designation

JET = Jetstream Tooling®
JETL = Jetstream Tooling® with P-lever clamp

JETB = Jetstream Tooling® with inlet on backend of shank
JETLB = Jetstream Tooling® with P-lever clamp and inlet on backend of shank

-PL = Plunging

Internal toolholders





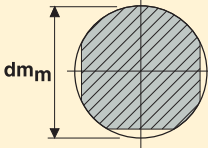

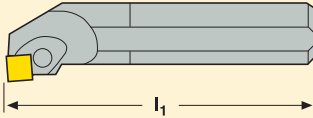

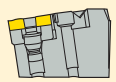
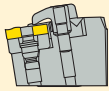
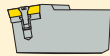
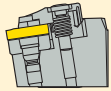









A	20	Q	-	P	W	L	N	R	06	R
1	2	3		4	5	6	7	8	9	10

1. Toolholder type A = Steel with coolant passage S = Solid steel E = Solid carbide with brazed* cutting head and coolant passage *Brazed or equivalent	2. Shank diameter  12 = 12 mm 20 = 20 mm 25 = 25 mm etc
--	---

3. Tool length 	K = 125 mm L = 140 mm M = 150 mm N = 160 mm P = 170 mm	Q = 180 mm R = 200 mm S = 250 mm T = 300 mm U = 350 mm	V = 400 mm
Standard length as above			

P	M	S	C
			
Pin/Wedge or Lever	Pin/Clamp	Screw	Clamp

A	B	C	D	E	H	K	L
							
M	O	P	R	S	T	V	W
							

6. Tool type

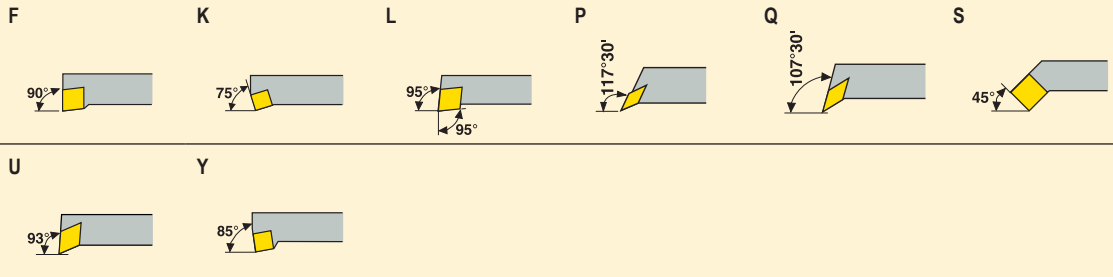

7. Insert side clearance angle

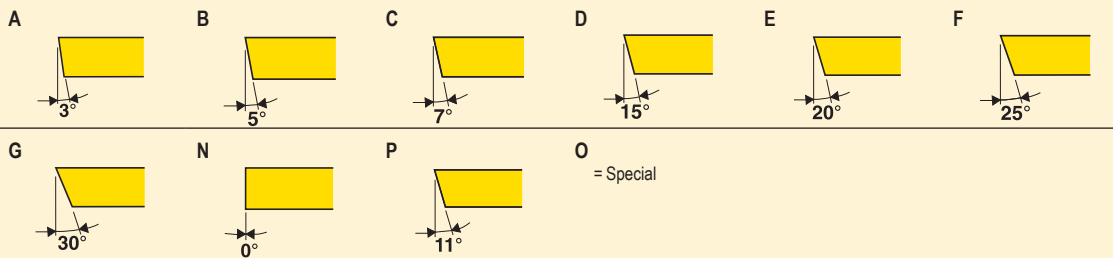

8. Cutting direction

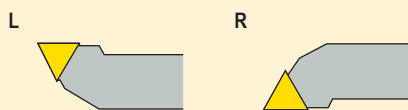

9. Cutting edge length

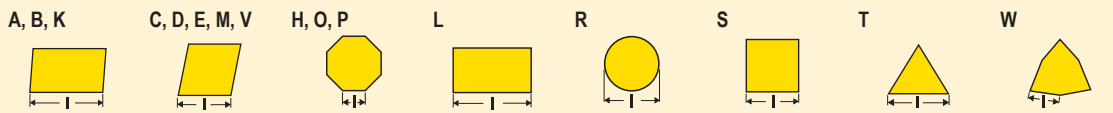

10. Internal designation

R = Round

Insert/Metric series, Extract from ISO 1832-2004

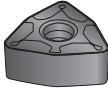

W	N	M	G	06	04	08		M3
1	2	3	4	5	6	7	8	9

Insert/Metric series, Extract from ISO 1832-2004

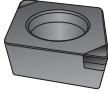

C	C	M	W	09	T3	08	S			L1		B
1	2	3	4	5	6	7	8	9	10	11	12	13

1. Insert shape

A	B	C	D	E	H	K	L
M	O	P	R	S	T	V	W

2. Insert side clearance angle

A	B	C	D	E	F
G	N	P	O	= Special	

3. Tolerances														
Tolerance-class	Tolerance +/- mm		For d, dimension mm											
			3,175*	3,969	4,064	4,760	6,350	9,525	12,700	15,875	19,050	25,400	31,750	38,100
	s	d												
A	0,025	0,025	•			•	•	•	•	•	•	•	•	•
C	0,025	0,025	•	•	•	•	•	•	•	•	•	•	•	•
E	0,025	0,025	•			•	•	•	•	•	•	•	•	•
F	0,025	0,013	•			•	•	•	•	•	•	•	•	•
G	0,130	0,025	•			•	•	•	•	•	•	•	•	•
H	0,025	0,013	•			•	•	•	•	•	•	•	•	•
J	0,025	0,050	•			•	•	•						
	0,025	0,080							•					
	0,025	0,100								•	•			
	0,025	0,130										•		
	0,025	0,150											•	•
K	0,025	0,050	•			•	•	•						
	0,025	0,080							•					
	0,025	0,100								•	•			
	0,025	0,130										•		
M	0,025	0,150											•	•
	0,130	0,050	•			•	•	•						
	0,130	0,080							•					
	0,130	0,100								•	•			
U	0,130	0,130										•		
	0,130	0,150											•	•
	0,130	0,180												
	0,130	0,250											•	•

* Not ISO

4. Fixing and/or chipbreaker						
A	B	G	M	N	R	
T	U	W	X	= Special		

5. Cutting edge length							
A, B, K	C, D, E, M, V	H, O, P	L	R	S	T	W

6. Thickness			
S	S	S	
			01 = 1,59 mm T3 = 3,97 mm 07 = 7,94 mm T1 = 1,98 mm 04 = 4,76 mm 08 = 8,00 mm 02 = 2,38 mm 05 = 5,56 mm 09 = 9,52 mm 03 = 3,18 mm 06 = 6,35 mm

7. Corner configuration

1st letter

A = 45°
D = 60°
E = 75°
F = 85°
P = 90°
Z = Special

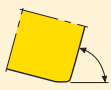

2nd letter

A = 45°
B = 5°
C = 7°
D = 15°
E = 20°
F = 25°
G = 30°
N = 0°
P = 11°
Z = Special



nose radius

M0 = round inserts (metric version)

005 = 0,05 mm
01 = 0,1 mm
02 = 0,2 mm
04 = 0,4 mm
08 = 0,8 mm
12 = 1,2 mm
etc



8. Cutting edge condition

F



E



T



S



W

= High feed inserts

Not mandatory information

9. Cutting direction

L



N

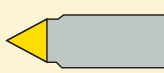

R



Not mandatory information

10. Internal designation

e.g. chipbreaker designation
F = Finishing
M = Medium
R = Roughing

e.g. edge designation
e.g. 01020 = 0,1 mm x 20°

Not mandatory information

11. Manufacturers option

Tip sizes:
L0
L1
L2
LF = full-face insert (sintered layer)

Not mandatory information

12. Internal designation

Turning
e.g. chipbreaker designation
F = Finishing
M = Medium
R = Roughing
WZ = Wiper (PCBN)
etc

Not mandatory information





13. No. of tips

B = 2
C = 3
D = 4
U = 4 (double sided)
V = 6 (double sided)

Not mandatory information

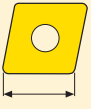
Insert shape and size

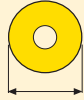
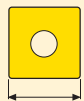
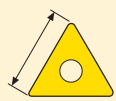
The application often determines what insert shape and size should be utilized

Insert shape	Insert size	Maximum depth of cut a_p (mm)															
		2	4	6	8	10	12	14	16	18	20	22	24	26	28		
C 	04	0.5															
	06	1.0															
	09	1.5	1.0														
	12	2.0	1.5	1.0													
	16	3.0	2.0	1.5	1.0												
	19	4.0	3.0	2.0	1.5	1.0											
	25	6.0	4.0	3.0	2.0	1.5	1.0										
D 	07	1.0															
	11	1.5	1.0														
	15	2.0	1.5	1.0													
R 	06	0.5															
	08	1.0															
	10	1.5	1.0														
	12	2.0	1.5	1.0													
	15	3.0	2.0	1.5	1.0												
	16	3.5	2.5	2.0	1.5												
	19	4.5	3.0	2.5	2.0	1.5											
	32	8.0	5.0	4.0	3.0	2.0	1.5	1.0									
S 	09	1.0															
	12	1.5	1.0														
	15	2.0	1.5	1.0													
	19	3.0	2.0	1.5	1.0												
	25	4.5	3.0	2.0	1.5	1.0											
	38	8.0	5.0	4.0	3.0	2.0	1.5	1.0									
T 	06	0.5															
	11	1.0															
	16	1.5	1.0														
	22	2.0	1.5	1.0													
	33	3.0	2.0	1.5	1.0												
V 	11	1.0															
	16	1.5	1.0														
	22	2.0	1.5	1.0													
W 	06	0.5															
	08	1.0															

D Toolholder

First choice for general machining, external

- For negative basic shape inserts with hole
- Robust, stable locking arrangement

The insert is locked in position by means of a clamp which presses the insert into and down onto the fixed insert seat

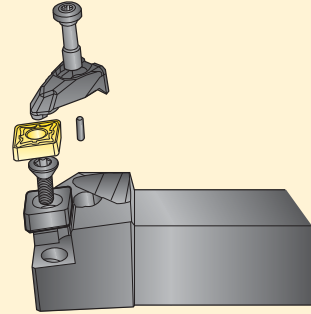

P Toolholder

A complement to the D Toolholder, external

- For negative inserts with hole
- No clamp on the top, facilitates free chip flow

In the illustration when the clamping screw is tightened and the toggle lever secures the insert in the insert seat

In the alternative design the clamping screw act upon the wedge that fix the insert towards the centre pin

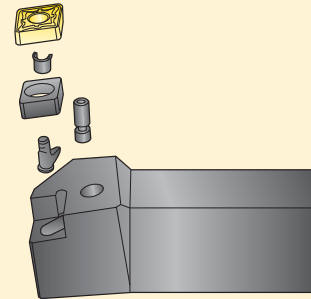

C Toolholder

Designed mainly for Seco PCBN inserts without hole

The insert is locked in position by means of a clamp, which is equipped with a carbide plate

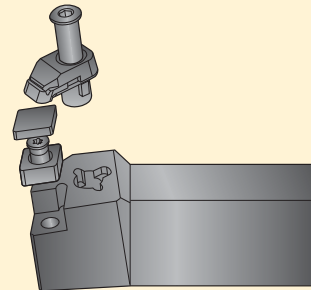

S Toolholder

For external and internal turning with positive inserts

- For positive basic shape inserts with hole

The insert is locked in position by a centre screw

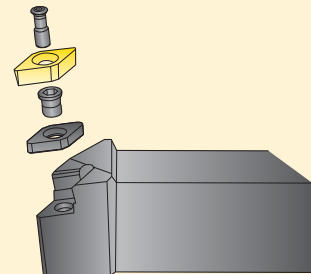

Insert type and size

The insert type and size are often determined by the toolholder choice.
The code on the insert must correspond to the code on the toolholder.

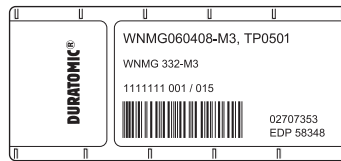

Insert type and size

Secolor is a system for presenting the application area for a specific insert. It is based on a matrix with eighteen squares symbolizing different workpiece materials and different machining conditions. The geometry of the insert i.e. the basic shape and the chipbreaker, together with the carbide grade forms the application area that the insert is meant for.

Black dots in the matrix indicate the main application areas for the inserts and circles indicate alternative areas.

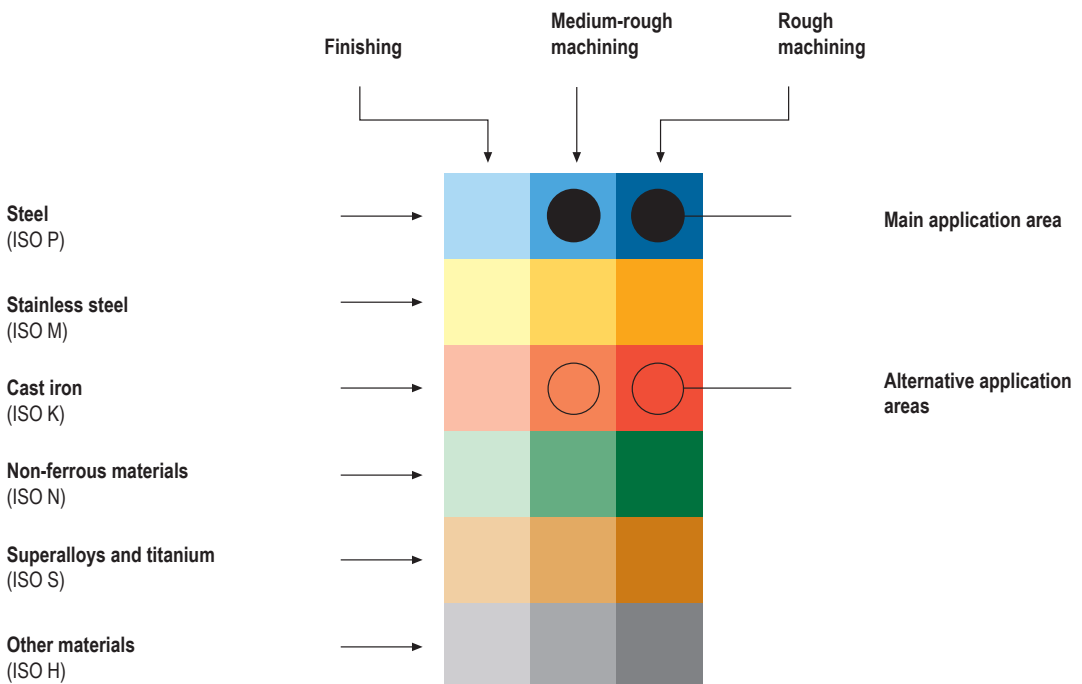

Chipbreakers

Chipbreaker application areas

The chipbreakers are designed to give the insert proper edge geometry for different application areas. Chipbreaker designations describe the application area as follows:

Letters: F = Finishing
M = Medium turning
R = Roughing

Digits: 1 = Low edge strength
9 = High edge strength

The colours in the chart indicates the ISO material group the chipbreakers are adaptable for.

ISO material group use



Stainless steel
(ISO M)



Steel
(ISO P)
Stainless steel
(ISO M)



Steel
(ISO P)
Cast iron
(ISO K)



Steel
(ISO P)
Stainless steel
(ISO M)
Cast iron
(ISO K)

Chipbreaker chart for negative basic shape inserts

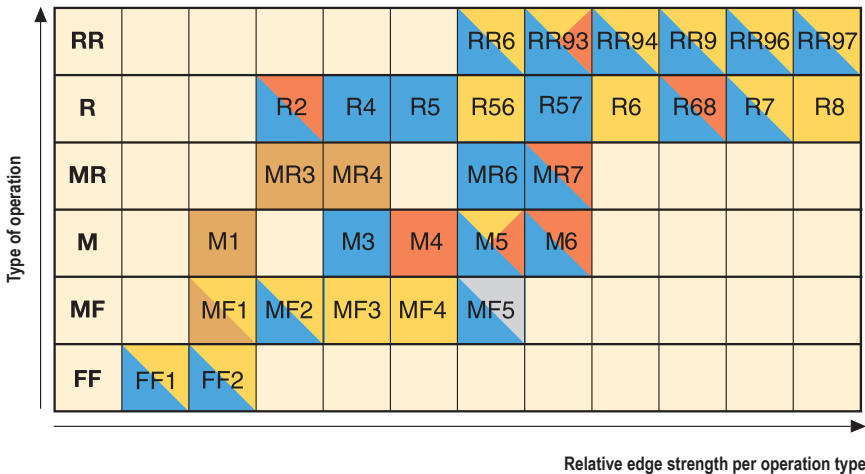

Chipbreaker chart for positive basic shape inserts

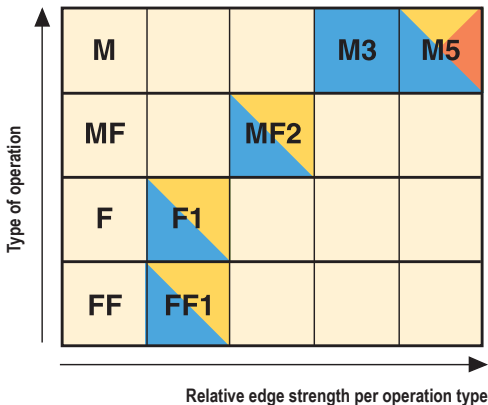

<p>-MF2</p>	<p>WNMG0804..</p>	<p>For finishing</p>
-------------	-------------------	----------------------

<p>-M3</p>	<p>WNMG0804..</p>	<p>For general machining</p>
------------	-------------------	------------------------------

<p>-M5</p>	<p>WNMG0804..</p>	<p>For roughing</p>
------------	-------------------	---------------------

Complete programme is shown on the following pages.

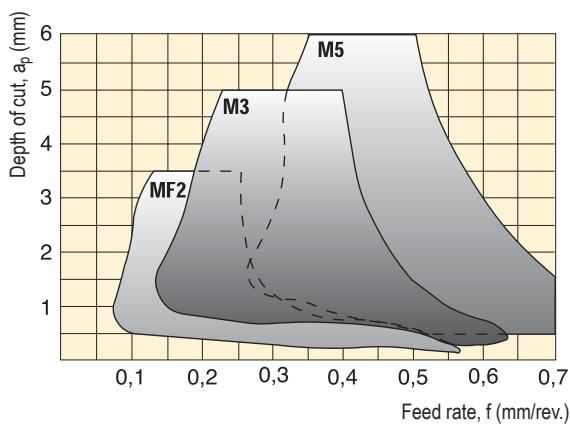

Insert grades

The Seco range consists of coated (CVD and PVD), uncoated, and cermet grades.

The designation of the grades indicates a ranking regarding their wear resistance and toughness behaviour.

All the grades are also classified according to ISO (P, M, K, N, S, H).

The black areas in the chart indicate an insert's main ISO application groups and the white areas indicate other supplementary application groups.

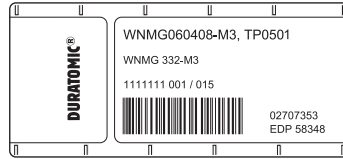

Indicative ISO classification of the grades

Grades	Steel					Stainless steel				Cast iron				Non-ferrous metals				Superalloys and titanium				Hard materials						
	P					M				K				N				S				H						
	P01	P10	P20	P30	P40	P50	M01	M10	M20	M30	M40	K01	K10	K20	K30	K40	N01	N10	N20	N30	S01	S10	S20	S30	H01	H10	H20	H30
CVD	TP0501	Black	Black	Black	Black	Black	White	White	White	White	White	Black	Black	Black	Black	Black	White	White	White	White	White	White	White	White	White	White	White	White
	TP1501	Black	Black	Black	Black	Black	White	White	White	White	White	Black	Black	Black	Black	Black	White	White	White	White	White	White	White	White	White	White	White	White
	TP2501	Black	Black	Black	Black	Black	White	White	White	White	White	Black	Black	Black	Black	Black	White	White	White	White	White	White	White	White	White	White	White	White
	TP3500	Black	Black	Black	Black	Black	White	White	White	White	White	Black	Black	Black	Black	Black	White	White	White	White	White	White	White	White	White	White	White	White
	TP200	Black	Black	Black	Black	Black	White	White	White	White	White	Black	Black	Black	Black	Black	White	White	White	White	White	White	White	White	White	White	White	White
	TP40	Black	Black	Black	Black	Black	White	White	White	White	White	Black	Black	Black	Black	Black	White	White	White	White	White	White	White	White	White	White	White	White
	TM2000	White	White	White	White	White	Black	Black	Black	Black	Black	White	White	White	White	White	Black	Black	Black	Black	White	White	White	White	White	White	White	White
	TM4000	White	White	White	White	White	Black	Black	Black	Black	Black	White	White	White	White	White	Black	Black	Black	Black	White	White	White	White	White	White	White	White
	TK1001	White	White	White	White	White	Black	Black	Black	Black	Black	White	White	White	White	White	Black	Black	Black	Black	White	White	White	White	White	White	White	White
	TK2001	White	White	White	White	White	Black	Black	Black	Black	Black	White	White	White	White	White	Black	Black	Black	Black	White	White	White	White	White	White	White	White
PVD	TH1500	White	White	White	White	White	Black	Black	Black	Black	Black	White	White	White	White	White	Black	Black	Black	Black	White	White	White	White	White	White	White	White
	TS2000	White	White	White	White	White	Black	Black	Black	Black	Black	White	White	White	White	White	Black	Black	Black	Black	White	White	White	White	White	White	White	White
	TS2500	White	White	White	White	White	Black	Black	Black	Black	Black	White	White	White	White	White	Black	Black	Black	Black	White	White	White	White	White	White	White	White
	TH1000	White	White	White	White	White	Black	Black	Black	Black	Black	White	White	White	White	White	Black	Black	Black	Black	White	White	White	White	White	White	White	White
	CP200	White	White	White	White	White	Black	Black	Black	Black	Black	White	White	White	White	White	Black	Black	Black	Black	White	White	White	White	White	White	White	White
	CP500	White	White	White	White	White	Black	Black	Black	Black	Black	White	White	White	White	White	Black	Black	Black	Black	White	White	White	White	White	White	White	White
Cermet	TP1030	Black	Black	Black	Black	Black	White	White	White	White	White	Black	Black	Black	Black	Black	White	White	White	White	White	White	White	White	White	White	White	White
	TP1020	Black	Black	Black	Black	Black	White	White	White	White	White	Black	Black	Black	Black	Black	White	White	White	White	White	White	White	White	White	White	White	White
Uncoated	890	White	White	White	White	White	Black	Black	Black	Black	Black	White	White	White	White	White	Black	Black	Black	Black	White	White	White	White	White	White	White	White
	HX	White	White	White	White	White	Black	Black	Black	Black	Black	White	White	White	White	White	Black	Black	Black	Black	White	White	White	White	White	White	White	White
	KX	White	White	White	White	White	Black	Black	Black	Black	Black	White	White	White	White	White	Black	Black	Black	Black	White	White	White	White	White	White	White	White
	883	White	White	White	White	White	Black	Black	Black	Black	Black	White	White	White	White	White	Black	Black	Black	Black	White	White	White	White	White	White	White	White

Jetstream Tooling® – Introduction

Seco Jetstream Tooling is a revolutionary solution to the problem of delivering coolant precisely to the cutting zone.

It works by delivering a concentrated high pressure jet of coolant at high velocity straight to the optimum position close to the cutting edge.

The jet lifts the chips away from rake face, improving chip control and tool life enabling increased cutting data.

It is proven to show improvement in nearly all material groups and with a wide choice of coolant pressures.

Seco Jetstream Tooling Duo holders, yet another innovation introduced to market, feature both a rake face and flank face jet, that may provide even better chip control and significantly longer tool life. Note the addition of roughing inducer option see page(s) 28.

The standard range of Jetstream Tooling is based on ISO toolholders. It can be mounted and used on a large selection of machines.

Coolant can either be supplied to the toolholder externally through a coolant hose which is attached to one of the inlet positions of the toolholder or internally in the case of Seco-Capto holders.

Hoses are available allowing the coolant supply to be connected to almost any position on the turret or tool block.

Seco Jetstream Tooling consists of holders for external turning, both square shanks and Seco-Capto backends.

Products are available for turning with positive and negative inserts, as well as MDT.

Maximum coolant pressure recommended for use with standard shank type Jetstream Tooling is 4000 psi (275 bar).

For Seco-Capto toolholders the maximum pressure is 1000 psi (70 bar). Here the limitation is the clamping units.

Note that it is up to the skilled artisan to make sure that all aspects of health and security are fulfilled.

Technical information

Designation of Jetstream Tooling holders follows ISO, please see Code keys page(s) 10-11, 14-15.

Jetstream Tooling for Grooving and Parting-off, see page(s) 439, 634, 652.



Finishing inducer

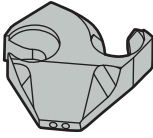

The mounted Jetstream Tooling® Finishing Inducer gives a universally applicable coolant jet, which provides a well positioned coolant wedge from finishing to medium-roughing applications. The inducers have a marked suffix “-F”.

Roughing inducer

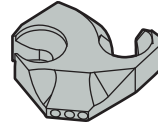

As accessories there are Jetstream Tooling® Roughing Inducers available for easy exchange providing a more boosted coolant wedge for clearer roughing applications or for cases demanding more space for the chip flow. The inducers have a marked suffix “-R”.

Changing the insert

Simply loosen both locking screws, and rotate the inducer clear of the insert. Check the condition of the tool, screws and O-ring and exchange regularly. Change or index the insert in the standard way before rotating the inducer back into position (make sure the inducer O-ring is still in place) and re-tighten the insert locking screw before locking the inducer.



Assembly instructions

For personal safety, Jetstream Tooling® should only be used with the machine door in a fully closed position in accordance with general machine safety procedures. Please ensure that the coolant hose is located correctly and fully tightened with all seals in position. The unused coolant hole should have a blanking plug fitted. Please note the maximum safe working pressures shown below.

The recommended torque for tightening the inducer locking screw 117.26-655 is 4 Nm, see page(s) 686 .

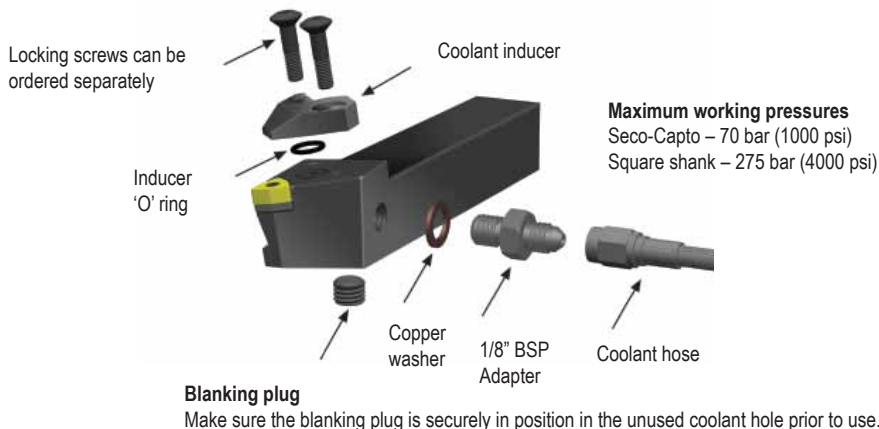

In the rare cases you need to shut off the Duo outlet underneath the insert, first remove the short screw in the side of the toolholder. Then mount the long plugging screw P6SS4X8 (02885815) using suitable glue to seal the thread (e.g. Loctite® 270). Plugging the underneath outlet should be considered permanent and irreversible.



Replace the short screw here with the long screw to shut off underneath coolant

Alternative coolant inlet

The range of toolholders denominated ...B in the description offers one coolant inlet underneath and one in the backend of the shank, see code keys on page(s) 14-15.

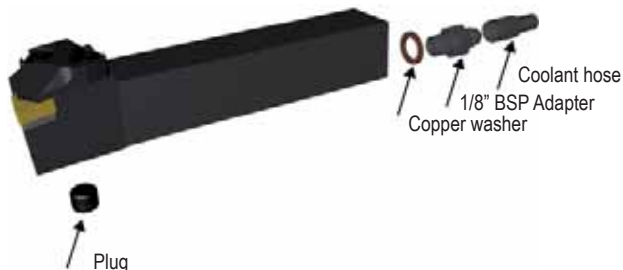

For Accessories, see page(s) 684.

Introduction

Seco-Capto is a quick-change modular tooling system for quick set-up and replacement of the cutting edge.

Advantages

- Quick tool change, increases the available productive time.
- Flexible, same toolholder can be used in different machines which reduces the tool stock.
- Modular, building of tools with extension adapters reduces the tool stock
- Rigid, no reduction of cutting data.
- Accurate, tapered polygon coupling produces a strong, self centering joint with repeatability within $\pm 0,002$ mm.

All toolholders have through holes for coolant.

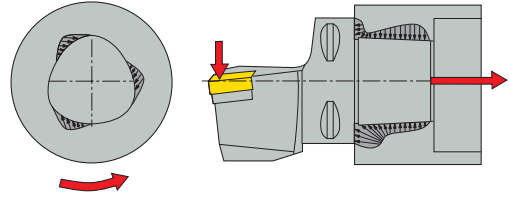

Clamping units

The manual clamping units are available in different versions;

- VDI shaft, straight or angled.
- Shank type to use with external toolholders.
- Cylindrical type to use with internal toolholders.
- Versions for special applications.

The unit is locked with a drawbar or screw from the back

Clamping units, please see page(s) 670-678.

Unclamped position

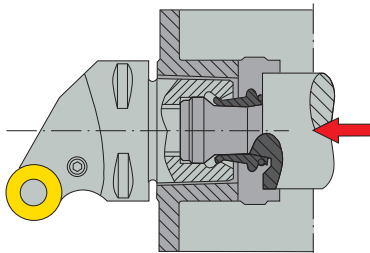

Clamping segments



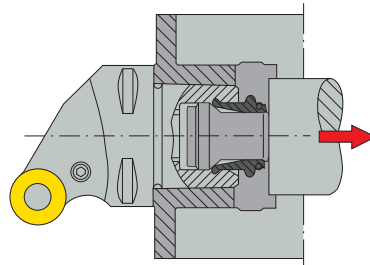

When the drawbar is pushed forward the diameter of the clamping segments decreases and the clamping segments are loosened from the cutting unit. The drawbar also pushes the cutting unit out from the joint.

Clamped position











When the drawbar is pulled back, the diameter of the clamping segments expands and the cutting unit is pulled into position.

Chipbreaker programme, negative basic shape inserts

	<p>-FF1</p>	<p>Chipbreaker for negative inserts. Used to achieve a very fine finish when turning slender steel and stainless steel components. Indicative machining range: $f = 0,08\text{--}0,30$ mm/rev, $a_p = 0,2\text{--}3,0$ mm.</p>
	<p>-FF2</p>	<p>Chipbreaker for negative inserts. Intended for fine-finishing and semi-finishing of steels and stainless steels. The positive, tight chip groove offers light cutting action combined with superior chip forming. Indicative machining range: $f = 0,08\text{--}0,30$ mm/rev, $a_p = 0,2\text{--}1,5$ mm.</p>
	<p>-MF1</p>	<p>Chipbreaker intended for machining stainless steel, superalloys and titanium alloys. Type ..GG insert has a sharp, precision ground edge. Type ..MG insert has a lightly honed cutting edge for increased strength. MF1 is intended for use in semi-finishing and finishing applications. Indicative machining range: $f = 0,08\text{--}0,30$ mm/rev, $a_p = 0,2\text{--}3,5$ mm.</p>
	<p>-MF2</p>	<p>First choice for finishing with negative inserts. Suitable for chip control at depths of cut down to 0,25 mm, provided that the feed rate is in excess of 0,25 mm/rev. Good capacity for medium rough machining. Indicative machining range: $f = 0,10\text{--}0,40$ mm/rev, $a_p = 0,2\text{--}3,0$ mm.</p>
	<p>-MF3</p>	<p>Chipbreaker with positive cutting rake angle intended for moderately difficult stainless steel. The MF3 is also intended for light roughing in relatively soft, "tacky" steel and difficult to machine stainless steel if the depth of cut is limited. MF3 can also be used for finishing of cast iron. Indicative machining range: $f = 0,2\text{--}0,4$ mm/rev, $a_p = 1\text{--}4$ mm.</p>
	<p>-MF4</p>	<p>Chipbreaker intended for medium/finishing of stainless steel, very open and highly positive geometry. Indicative machining range: $f = 0,15\text{--}0,50$ mm/rev, $a_p = 0,5\text{--}4,0$ mm.</p>
	<p>-MF5</p>	<p>Chipbreaker intended for medium finishing of steel and stainless steel at high feeds. Very easy cutting and open geometry. Indicative machining range: $f = 0,2\text{--}0,8$ mm/rev, $a_p = 0,2\text{--}2,7$ mm.</p>
	<p>-M1</p>	<p>Chipbreaker intended for superalloys and titanium alloys. It has a positive cutting rake angle which is slightly honed to increase the edge strength. Also available with a perfectly sharp edge (type ..GG insert). The M1 is intended for light roughing and for semi-finishing. Indicative machining range: $f = 0,2\text{--}0,4$ mm/rev, $a_p = 1,5\text{--}5,0$ mm.</p>





Chipbreaker programme, negative basic shape inserts

	<p>-M3</p>	<p>First choice for medium-rough machining and also the most versatile Seco chipbreaker. In most cases, it is the only chipbreaker needed. Offers the best useful life and best chipbreaking in a wide range of cutting data and workpiece materials. Suitable for precision forged and cast workpieces (NNS or Near Net Shape workpieces) as regards both chip control and edge strength. Indicative machining range: $f = 0,15-0,50$ mm/rev, $a_p = 0,5-5,0$ mm.</p>
	<p>-M4</p>	<p>Chipbreaker intended for cast iron. Positive rake angle with a narrow T-land gives low cutting forces. First choice for cast iron machining at high speeds. Indicative machining range: $f = 0,1-0,7$ mm/rev, $a_p = 0,2-0,7$ mm.</p>
	<p>-M5</p>	<p>The choice for roughing by means of double-sided inserts. Intended for demanding operations at high feed rates in steel, stainless steel and cast iron. Combines high edge strength with comparatively low cutting forces. Indicative machining range: $f = 0,3-0,7$ mm/rev, $a_p = 1,5-7,0$ mm.</p>
	<p>-M6</p>	<p>Strong double-sided chipbreaker, intended for semi-roughing and roughing of steel. A well-balanced design combining excellent chip control and relatively low cutting forces which provides reliable cutting action in both continuous as well as interrupted cuts. Well suited also for machining of ferritic and martensitic stainless steels. Indicative machining range: $f = 0,2-0,8$ mm/rev, $a_p = 1,0-7,0$ mm</p>
	<p>-MR3</p>	<p>Chipbreaker with a positive cutting rake angle that reduces cutting forces and gives a very high edge strength. Intended for medium-rough and rough machining of superalloys, titanium alloys and hardened steel. Indicative machining range: $f = 0,2-0,6$ mm/rev, $a_p = 1,5-7,0$ mm.</p>
	<p>-MR4</p>	<p>The MR4 has a negative T-land, which gives extremely high edge strength. The chipbreaker is intended for more difficult machining applications on superalloys and titanium alloys, such as intermittent cuts and the machining of parts with raw surface. Indicative machining range: $f = 0,15-0,50$ mm/rev, $a_p = 1,5-7,0$ mm.</p>
	<p>-MR6</p>	<p>Chipbreaker for medium and medium roughing of steel. Very easy cutting and open geometry. Double and single-sided. Indicative machining range: $f = 0,25-0,80$ mm/rev, $a_p = 0,9-5,0$ mm.</p>
	<p>-MR7</p>	<p>The strongest chipbreaker for double-sided inserts. The MR7 is suitable for high feed rates and depths of cut that normally require a single-sided insert. The chipbreaker has a wide negative T land, which gives high edge strength. Indicative machining range: $f = 0,35-0,90$ mm/rev, $a_p = 1,5-7,0$ mm.</p>

Chipbreaker programme, negative basic shape inserts

	<p>-R4</p>	<p>Chipbreaker for single-sided inserts. It has a positive cutting edge which gives low cutting forces. Indicative machining range: $f = 0,2\text{--}0,6$ mm/rev, $a_p = 2\text{--}10$ mm.</p>
	<p>-R5</p>	<p>Chipbreaker for single-sided inserts. Recommended for medium-roughing of steel. Indicative machining range: $f = 0,3\text{--}1,0$ mm/rev, $a_p = 2\text{--}12$ mm.</p>
	<p>-56 -R56</p>	<p>Chipbreaker with easy-cutting geometry for single-sided inserts. Intended for stainless steel machining applications. Indicative machining range: $f = 0,4\text{--}0,8$ mm/rev, $a_p = 2\text{--}12$ mm.</p>
	<p>-57 -R57</p>	<p>Chipbreaker for single-sided roughing inserts. Recommended for roughing operations on steel at high feed rates and high depth of cut. Indicative machining range: $f = 0,45\text{--}1,10$ mm/rev, $a_p = 2\text{--}12$ mm.</p>
	<p>-R6</p>	<p>Chipbreaker for single-sided inserts. Recommended for medium-roughing of stainless steel. Indicative machining range: $f = 0,25\text{--}0,70$ mm/rev, $a_p = 2\text{--}10$ mm.</p>
	<p>-R68</p>	<p>Chipbreaker for single sided insert. Recommended for heavy-roughing of steel. Indicative machining range: $f = 0,4\text{--}1,4$ mm/rev, $a_p = 4\text{--}14$ mm.</p>
	<p>-R7</p>	<p>A strong but easy-cutting chipbreaker for single sided inserts. The R7 is well suited for intermittent machining of both stainless and ordinary carbon steel. Indicative machining range: $f = 0,4\text{--}1,6$ mm/rev, $a_p = 3\text{--}18$ mm.</p>
	<p>-R8</p>	<p>A very strong chipbreaker for single-sided inserts. The R8 is intended for high feed rates when machining castings and forgings of austenitic stainless steel. Indicative machining range: $f = 0,35\text{--}0,80$ mm/rev, $a_p = 2\text{--}12$ mm.</p>

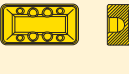

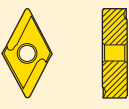

Chipbreaker programme, negative basic shape inserts

	<p>-RR6</p>	<p>A very easy-cutting chipbreaker for single-sided inserts. Recommended for roughing of stainless steel and steel. Indicative machining range: $f = 0,3\text{--}1,0$ mm/rev, $a_p = 2\text{--}12$ mm.</p>
	<p>-RR9</p>	<p>Extremely strong chipbreaker for single-sided negative inserts, for use at high feed rates. Suitable for difficult castings and forgings and for austenitic stainless steel. Indicative machining range: $f = 0,5\text{--}1,2$ mm/rev, $a_p = 2,5\text{--}15,0$ mm.</p>
	<p>-RR93</p>	<p>Heavy roughing chipbreaker for negative single-sided inserts for very high parameters for all materials. Indicative machining range: $f = 1,3\text{--}2,6$ mm/rev, $a_p = 10\text{--}30$ mm.</p>
	<p>-RR96</p>	<p>Heavy roughing chipbreaker for negative single-sided inserts for high parameters and chip control for all materials. Indicative machining range for LNMX50: $f = 1,5\text{--}2,6$ mm/rev, $a_p = 12\text{--}36$ mm.</p>
	<p>-RR97</p>	<p>Heavy roughing chipbreaker for negative single-sided inserts for soft materials. Indicative machining range for LNMX50: $f = 1,5\text{--}2,6$ mm/rev, $a_p = 10\text{--}36$ mm.</p>
	<p>-UX</p>	<p>Chipbreaker for negative inserts. Positive cutting rake with sharp edge. Low cutting force. Suitable for slim components. Indicative machining range: $f = 0,2\text{--}0,4$ mm/rev, $a_p = 1,0\text{--}6,0$ mm.</p>





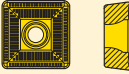







Chipbreaker programme, positive basic shape inserts

	<p>-AL</p>	<p>Chipbreaker for positive inserts. Intended for machining of aluminium alloys. The highly polished rake face and the very large rake angle ensure extremely light cutting action. Indicative machining range: $f = 0,15\text{--}0,60$ mm/rev, $a_p = 0,5\text{--}4,0$ mm.</p>
	<p>-FF1</p>	<p>Chipbreaker for positive inserts. Used to achieve a very fine finish when turning slender steel and stainless steel components. Indicative machining range: $f = 0,05\text{--}0,30$ mm/rev, $a_p = 0,2\text{--}2,0$ mm.</p>
	<p>-F1</p>	<p>Chipbreaker for positive inserts. Positive geometry with sharp cutting edge gives easy-cutting properties. Suitable for high feed rates at fine depths of cut in precision forgings and castings. Indicative machining range: $f = 0,1\text{--}0,5$ mm/rev, $a_p = 0,2\text{--}3,0$ mm. Machining in bar automatics, for instance: $f = 0,08\text{--}0,25$ mm/rev, $a_p = 1\text{--}3$ mm.</p>
	<p>-F2</p>	<p>A reliable semi-finishing to medium roughing chipbreaker ensuring safe chip flow. Suitable for medium cuts in steel and stainless steels application including boring. Indicative machining range: $f = 0,12\text{--}0,60$ mm/rev, $a_p = 0,2\text{--}4,0$ mm.</p>
	<p>-MF2</p>	<p>A versatile finishing to semi-finishing chipbreaker with light-cutting action for positive inserts. Suitable for a wide range of cuts in steel and stainless steel finishing applications including boring. Indicative machining range: $f = 0,08\text{--}0,50$ mm/rev, $a_p = 0,15\text{--}3,00$ mm.</p>
	<p>-M3</p>	<p>A reliable semi-finishing to medium roughing chipbreaker ensuring safe chip flow. Suitable for medium cuts in steel and stainless steels application including boring. Indicative machining range: $f = 0,12\text{--}0,60$ mm/rev, $a_p = 0,2\text{--}4,0$ mm.</p>
	<p>-M5</p>	<p>A highly reliable chipbreaker for positive inserts. Intended for medium-rough and rough machining of steels, stainless steels and cast iron. Combines high edge strength with comparatively low cutting forces. Safe action in interruptions and rough skin on parts also including boring. Indicative machining range: $f = 0,15\text{--}0,60$ mm/rev, $a_p = 1\text{--}5$ mm</p>
	<p>-R2</p>	<p>Chipbreaker for large inserts intended for finishing of railway wheels. Indicative machining range: $f = 0,3\text{--}0,8$ mm/rev, $a_p = 1,0\text{--}5,0$ mm.</p>







Chipbreaker programme, positive basic shape inserts

	<p>-RR94</p>	<p>Chipbreaker for large inserts intended for roughing of railway wheels. Indicative machining range: $f = 0,6\text{--}1,5$ mm/rev, $a_p = 3,0\text{--}10,0$ mm.</p>
	<p>-RR96</p>	<p>Chipbreaker for large inserts intended for machining of steel with high depth of cut and large feed rates. Indicative machining range: $f = 0,6\text{--}2,2$ mm/rev, $a_p = 3,0\text{--}24,0$ mm.</p>
	<p>-RR97</p>	<p>Chipbreaker for large inserts intended for machining of steel with high depth of cut and large feed rates. The –RR97 geometry is stronger than the –RR96. Indicative machining range: $f = 0,8\text{--}2,2$ mm/rev, $a_p = 3,0\text{--}24,0$ mm.</p>
	<p>-UX</p>	<p>Chipbreaker for positive inserts. Smooth and easy chip flow on finishing and medium roughing in steel and stainless steel. Well suited for slim components. Indicative machining range: $f = 0,05\text{--}0,40$ mm/rev, $a_p = 0,5\text{--}4,0$ mm.</p>







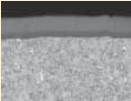

CVD coated grades

<p>TP0501</p>		<p>Duratomic® technology coated grade. A grade having extremely high degree of heat and wear resistance for many steel applications such as in alloy steels and especially capable under dry conditions, but also applicable for demanding applications in cast irons.</p> <p>Ti(C,N) + Al₂O₃ + ...</p>
<p>TP1501</p>		<p>Duratomic® technology coated grade. Highly heat and wear resistant grade extremely well suited for productive general turning of steels and a useful backup in other material groups.</p> <p>Ti(C,N) + Al₂O₃ + ...</p>
<p>TP2501</p>		<p>Duratomic® technology coated grade. Designed with high wear resistance and edge strength applicable in a wide range of turning applications in steels as well as many stainless steels and cast irons.</p> <p>Ti(C,N) + Al₂O₃ + ...</p>
<p>TP3500</p> 		<p>Duratomic® technology coated grade. Enhanced edge toughness still with the characteristic high wear resistance intended for versatile performance in turning applications in steels as well as stainless steels especially including interrupted cuts.</p> <p>Ti(C,N) + Al₂O₃</p>
<p>TP200</p> 		<p>Universal grade for high versatile performance over a wide range of application in steels, stainless steels and cast irons.</p> <p>Ti(C,N) + Al₂O₃ + TiN</p>
<p>TP40</p> 		<p>Universal grade for a extremely secure performance in the most demanding application from steels, stainless steels to superalloys especially in castings and forgings.</p> <p>TiC/Ti(C,N) + TiN</p>
<p>TH1500</p> 		<p>Duratomic® technology coated grade. An extremely hard super micrograin grade intended for machining of partly hardened steels and provides an alternative for cast iron finishing.</p> <p>Ti(C,N) + Al₂O₃</p>
<p>TM2000</p> 		<p>Duratomic® technology coated grade. Highly resistant and optimized grade for stainless steel machining with capability in softer steels.</p> <p>Ti(C,N) + Al₂O₃</p>

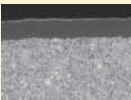

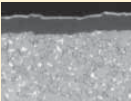

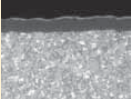
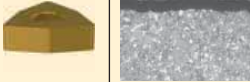
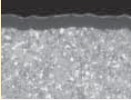



CVD coated grades

<p>TM4000</p> 		<p>Duratomic® technology coated grade. A highly capable stainless steel grade with combinations of high resistance and superior edge toughness making it versatile with high performance also in many steels.</p> <p>Ti(C,N) + Al₂O₃</p>
<p>TK1001</p> 		<p>Duratomic® technology coated grade. A extremely wear resistant optimized grade choice for machining of grey cast iron and easier ductile cast irons.</p> <p>Ti(C,N) + Al₂O₃</p>
<p>TK2001</p> 		<p>Duratomic® technology coated grade. A highly wear resistant grade for cast irons in general as well as in steels. The grade is particularly capable in machining of ductile (nodular) cast irons also in more demanding setups and interrupted cuts.</p> <p>Ti(C,N) + Al₂O₃</p>





PVD coated grades

<p>TH1000</p> 		<p>Very hard supermicrograin grade intended for partly hardened steel components as well as generally workpiece materials such as superalloys and due to remarkable edge toughness it also provides high performance in interrupted cuts and hard-surface removal.</p> <p>Ti-Al-Si-N nanolaminate coating</p>
<p>TS2000</p> 		<p>Hard micrograin wear resistant grade intended for finishing in superalloys and titanium as well as in many in stainless steels.</p> <p>(Ti,Al)N + TiN</p>
<p>TS2500</p> 		<p>Relatively hard micrograin grade for machining of superalloys and titanium in roughing applications and due to its design also applicable in a wide range of materials such as stainless steels.</p> <p>(Ti,Al)N + TiN</p>
<p>CP200</p> 		<p>Hard micrograin grade principally intended for finishing in superalloys and titanium. Also works well in stainless steels.</p> <p>(Ti, Al) N + TiN</p>
<p>CP500</p> 		<p>Tough micrograin grade intended for finishing to medium-roughing of stainless steels but with wide applicability for example in steels and aluminium alloys. Especially suitable in intermittent cuts.</p> <p>(Ti,Al)N + TiN</p>
<p>CP600</p> 		<p>Very tough micrograin grade intended for stainless steels and steels applicable but generally applicable when ever high edge toughness required e.g. more difficult interrupted cuts.</p> <p>(Ti,Al)N + TiN</p>

Uncoated

<p>HX</p> 		<p>Universal uncoated grade intended for machining of cast iron and hardened steels useful also in non-ferrous materials.</p>
<p>KX</p> 		<p>Optimized micrograin grade intended for the machining of aluminium and other non-ferrous materials.</p>
<p>883</p> 		<p>Relatively hard and still tough uncoated micrograin grade for machining of titanium in roughing applications and also suitable for superalloys.</p>
<p>890</p> 		<p>High hardness uncoated micrograin grade maintaining good toughness intended for superalloys and titanium can also be applied in other materials.</p>

Cermet

<p>TP1020</p> 		<p>High wear resistance cermet grade for highest surface finish with predictability, first of all, in steels and stainless steels.</p>
<p>TP1030</p> 		<p>Coated highly wear resistant cermet grade for high surface finish and productivity requirements mainly used in steels and stainless steels. Ti-Al-Si-N nanolaminate coating.</p>

High Feed Wiper inserts – Introduction

The Seco High Feed Wiper inserts offer

- Excellent surface finish at high feed rates.
- Superior surface finish at normal feed rates.

The use of Seco High Feed Wiper inserts often eliminates the need for finishing operations (including grinding).

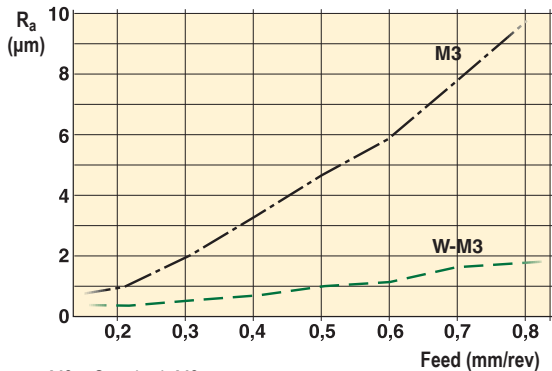

M3 = Standard -M3
W-M3 = Wiper -M3

The diagram shows the superior surface finish in steel achieved with a Seco High Feed W-M3 wiper insert compared to a conventional insert.

CNMG120408W-M3, TP2500, $\kappa = 95^\circ$, $a_p = 1$ mm, cutting speed adjusted for feed, workpiece material: (steel) SMG P4.

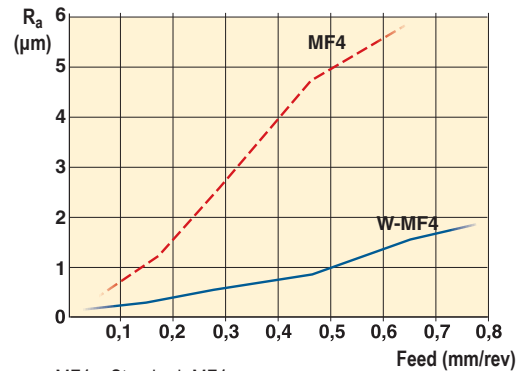

MF4 = Standard -MF4
W-MF4 = Wiper -MF4

When applying a Seco High Feed W-MF4 wiper insert in stainless steel the diagram shows the superior surface finish achieved compared to a conventional insert.

CNMG120408W-MF4, TM4000 $\kappa = 95^\circ$, $a_p = 1$ mm, cutting speed tool life adjusted for feed in SMG M2 (stainless steel).

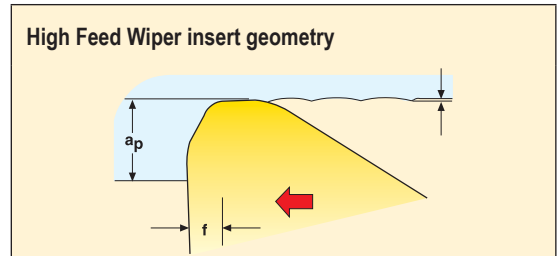
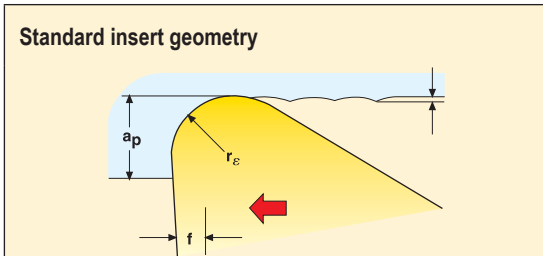

Indicative chipbreaking range

Positive inserts, C and W

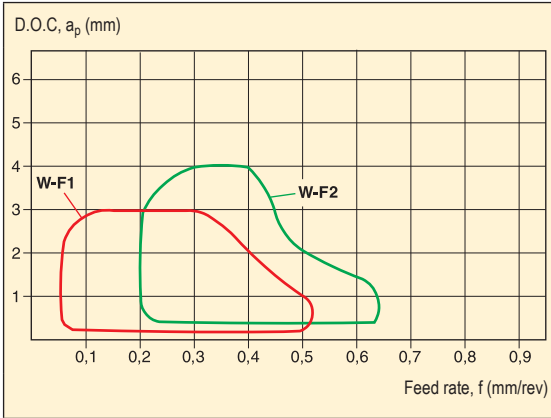

Positive inserts, D and T

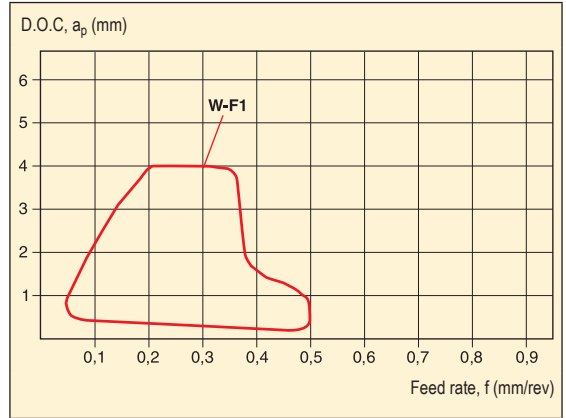

Negative inserts, C and W

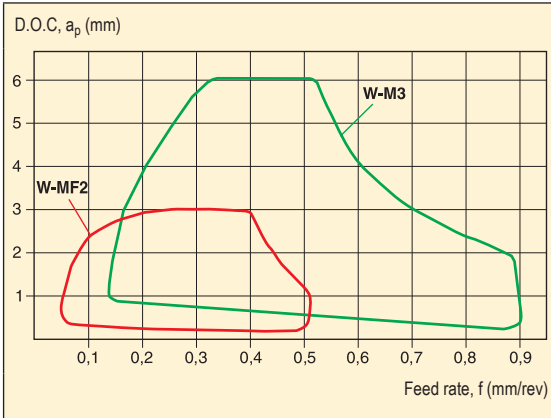

Negative inserts, D and T

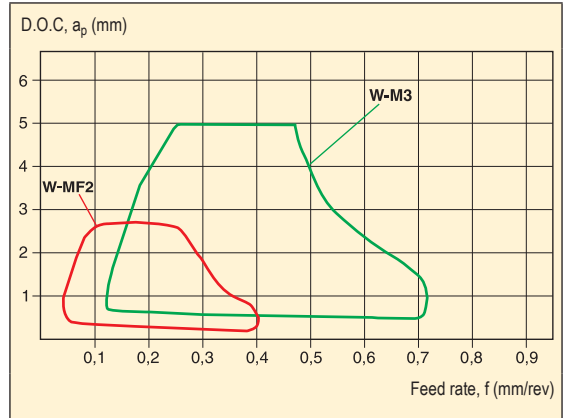

Negative inserts, C and S Chipbreaker W-R4

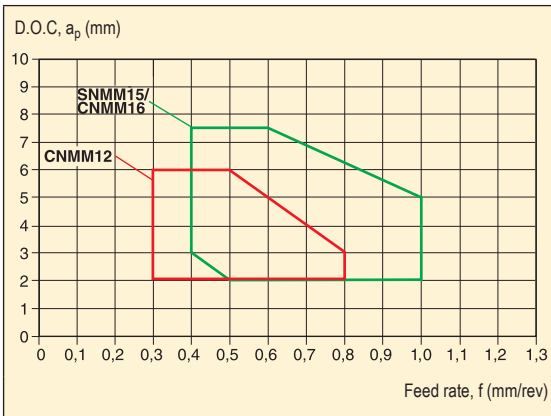

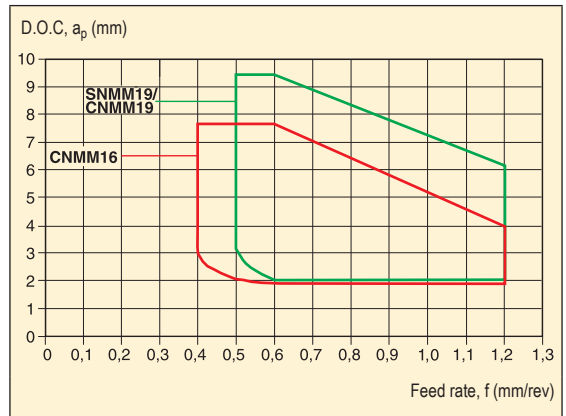

Negative inserts, C and S Chipbreaker W-R7



Chipbreaker programme, High Feed Wiper inserts

	W-F1	<p>A versatile chipbreaker for positive inserts. For finishing machining of steel, stainless steel and cast iron giving good surface finish. Suitable for high feed rates at small depths of cut. Indicative machining range: $f = 0,05-0,50$ mm/rev, $a_p = 0,25-3,00$ mm.</p>
	W-F2	<p>Chipbreaker for high feed finishing and medium-roughing machining of steel and cast iron. Ensures safe and well directed chip flow and good surface finish. Indicative machining range: $f = 0,20-0,65$ mm/rev, $a_p = 0,5-4,0$ mm.</p>
	W-FF2	<p>Chipbreaker for high feed finishing of steel and stainless steel. Wide chip control range in finishing and generates a superior surface quality. Indicative machining range: $f = 0,1-0,5$ mm/rev, $a_p = 0,2-1,5$ mm.</p>
	W-MF2	<p>First choice for finishing with both positive and negative inserts. Chipbreaker suitable for finishing machining of steel, stainless steel and cast iron at high feed rates giving good surface finish. Indicative machining range: $f = 0,05-0,60$ mm/rev, $a_p = 0,5-4,0$ mm.</p>
	W-MF4	<p>Easy cutting action chipbreaker for high feed machining of stainless steel. Provides good surface finish in finishing operations and High Feed Wiper productivity in medium-roughing machining. Indicative machining range: $f = 0,05-0,90$ mm/rev, $a_p = 0,2 - 6,0$ mm</p>
	W-MF5	<p>Chipbreaker intended for medium finishing of steel at high feed. The geometry is very open and highly positive and equipped with wiper radius. Indicative machining range: $f = 0,2-0,8$ mm/rev, $a_p = 0,2-2,7$ mm.</p>
	W-M3	<p>Versatile chipbreaker for high feed finishing and medium-roughing machining of steel, stainless steel and cast iron. Operates in a wide application area. Gives a good surface finish even at high feeds. Indicative machining range: $f = 0,2-0,9$ mm/rev, $a_p = 0,5-6,0$ mm.</p>
	W-M6	<p>Strong double-sided chipbreaker, intended for high-feed semi-roughing and roughing of steel. A well-balanced design combining excellent chip control and relatively low cutting forces which provides reliable cutting action in both continuous as well as interrupted cuts. Indicative machining range: $f = 0,3-1,0$ mm/rev, $a_p = 1,0-7,0$ mm</p>

Chipbreaker programme, High Feed inserts

	<p>W-R4</p>	<p>Chipbreaker for single sided inserts intended for high feed medium-roughing and rough machining of steel, stainless steel and cast iron. Gives a good surface finish even at high feeds. Low cutting forces. Indicative machining range: $f = 0,3-1,0$ mm/rev, $a_p = 2,0-7,5$ mm.</p>
	<p>W-R7</p>	<p>A strong easy cutting chipbreaker for single sided inserts. Intended for the highest feeds when medium-roughing and roughing machining of steel, stainless steel and cast iron. Gives a good surface finish even at the higher feeds. Indicative machining range: $f = 0,4-1,2$ mm/rev, $a_p = 2,0-9,5$ mm.</p>
	<p>-WZ -WZN -WZP</p>	<p>Wiper geometries on PCBN inserts. Available in various insert styles in solid or brazed format. Developed for machining pearlitic grey cast iron and hardened steel. Gives a high quality surface finish at high feeds. See page(s) 46 for further details.</p>

Operation guidelines

- The favourable surface finish results are lost, if the cutting edge angle diverges from 95° (C-and W-style inserts).
- Max diversion allowed: $\pm 2^\circ$.
- Back-turning is NOT recommended.

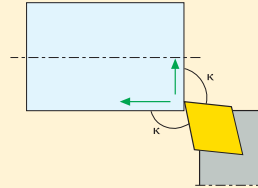

- The favourable surface finish results are lost, if the cutting edge angle diverges from 93° (D-and T-style inserts).
- Max diversion allowed: $\pm 2^\circ$.
- Back-turning is NOT recommended.

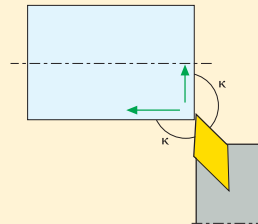

C-style High Feed inserts

On C-style High Feed inserts, except for PCBN inserts, the wiper geometry is also located on the 100° corner.

Chipbreaker W-R4 and W-R7

When using W-R4 or W-R7 chipbreaker use a toolholder with P- or M-type clamping.

S-style High Feed inserts

S-style High Feed insert to be used in a toolholder with 75° setting angle. The favourable surface finish results are lost, if the cutting edge angle diverges from 75°. Max diversion allowed: $\pm 2^\circ$.

Copying with D- and T-style Wiper inserts

Since D- and T-style High Feed inserts not are designed within ISO-tolerances, an adjustment in the tool offset must be made.

A deviation from the nominal nose radius shape, will always occur (D1, D2) when going towards a corner.

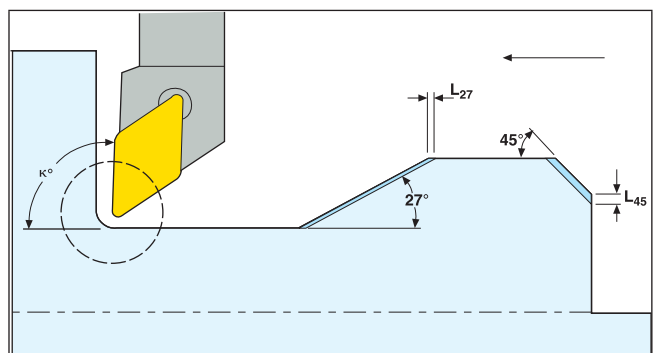
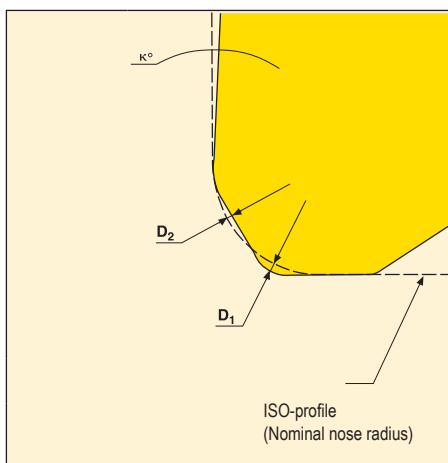

When copying with a D- or T-style High Feed insert, an adjustment must be made for dimensional deviations.

The High Feed geometry on a D-and T-style insert does not provide an exact corner radius.

Seco Crossbill™ Wiper insert

A deviation from the normal radius shape will always occur when a standard wiper geometry is used to machine towards a corner/face.

The Crossbill High Feed insert gives the opportunity to produce a radius without deviation from the normal shape and without losing the advantages from a standard wiper insert.

The Seco High Feed inserts are available in PCBN grade CBN010.

Design/Function

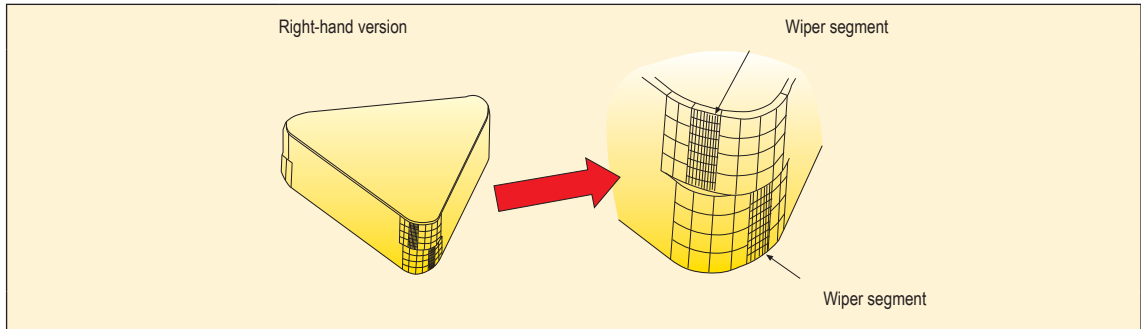
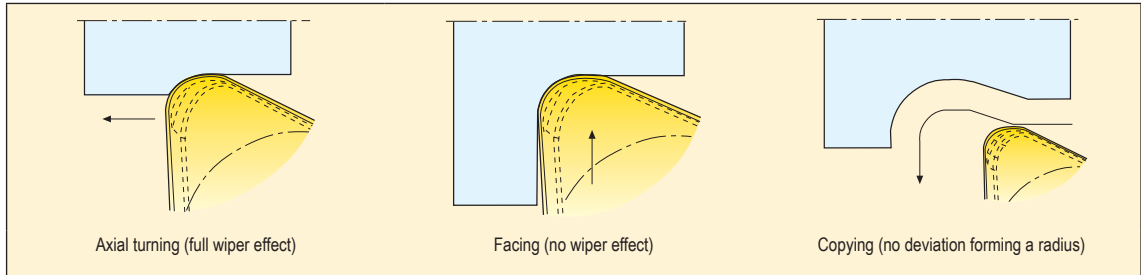

The Helix™ wiper technology

Our unique patented, Helix™ wiper concept is designed for optimization in finish machining. It has a wiper on both sides of the corner radii (as the standard) but the protection chamfer is twisted from negative to positive or from positive to negative depending on the application.

It is available in grade CBN050C. The following considerations apply when selecting the appropriate geometry:

Positive Wiper, WZP

- Reducing vibrations in weak set-ups
- Lower radial cutting forces
- Used where standard wiper cannot be used

Negative Wiper, WZN

- Longer tool life
- Reducing vibrations in stable set-ups
- Increasing compressive stresses

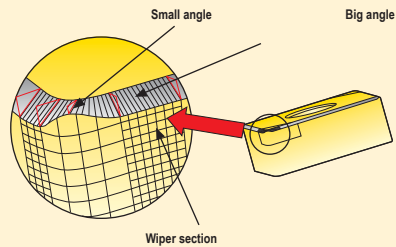
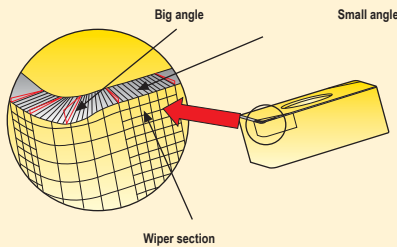

Nomenclature and formulae

RPM	$n = \frac{v_c \cdot 1000}{\pi \cdot D_c}$	(rev/min)
------------	--	-----------

Cutting speed	$v_c = \frac{n \cdot \pi \cdot D_c}{1000}$	(m/min)
----------------------	--	---------

Surface finish (arithmetic average deviation) Rough estimates	$R_a = \frac{f^2 \cdot 50}{r_\varepsilon}$	(μm)
	$R_a = \frac{R_t}{3,5}$	(μm)
Refined estimate	$R_a \approx 770 \cdot \left(1 - \frac{\frac{f}{2 r_\varepsilon}}{\arcsin\left(\frac{f}{2 r_\varepsilon}\right)}\right) \cdot r_\varepsilon \text{ (}\mu\text{m)}$	
Valid for:	$f \leq 2 \sqrt{a_p (2 r_\varepsilon - a_p)} \leq 2 r_\varepsilon$	
	see note and table in page(s) 48	

Surface finish total height of profile estimate	$R_t = k \cdot \frac{f^2 \cdot 1000}{8 \cdot r_\varepsilon}$	(μm)
---	--	-------------------

Power demand estimate	$P_c = \frac{v_c \cdot f \cdot a_p}{25}$	(kW)
---------------------------------	--	------

Metal removal rate	$Q = v_c \cdot f \cdot a_p$	(cm^3/min)
---------------------------	-----------------------------	------------------------------

a_p	= Depth of cut	(mm)
D_c	= Workpiece diameter	(mm)
f	= Feed rate	(mm/rev)
h	= Chip thickness	(mm)
k	= Constant 1,0 for steel and stainless steel 1,4 for cast iron	
n	= RPM	(rev/min)
P_c	= Power demand	(kW)
Q	= Metal removal rate	(cm^3/min)
R_a	= Surface finish (arithmetic average deviation)	(μm)
r_ε	= Nose radius	(mm)
R_t	= Total height of profile surface	(μm)
v_c	= Cutting speed	(m/min)

Depth of cut

The maximum depth of cut that can be used depends on a number of factors. Machine power, stability, workpiece material, insert shape and size, nose radius, chipbreaker, grade and cutting edge angle.

Start with the insert size to get an indication and proceed with the recommendations for the chosen chipbreaker. This will give a suitable maximum depth of cut.

A rule of thumb could be that the minimum depth of cut should not be smaller than the nose radius.

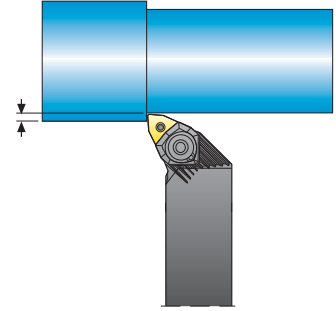

Feed rate

The maximum feed rate that can be used depends on a number of factors. Machine power, stability, workpiece material, insert shape and size, nose radius, chipbreaker, grade and cutting edge angle. Another, very important factor is the required surface finish. Start by looking at the recommendations for the chosen chipbreaker. Then look in the surface finish table below to be sure that the required surface finish can be achieved.

The maximum feed rate should preferably be considerably smaller than the nose radius.

A too low feed rate can result in poor chipbreaking and tool life.

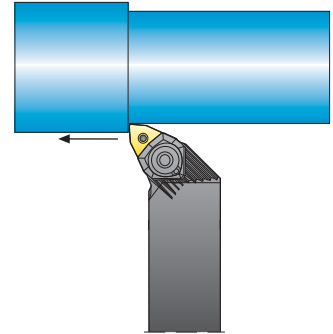

Surface finish

A large nose radius normally produces a better surface finish.

The table gives recommended maximum, theoretical, feed rates to achieve a specified R_a -value.

Always consider the possibility to use high feed inserts (Seco Wiper), for turning with high feed with retained surface finish.

For more information, see page(s) 41-46.

Note: The refined estimate R_a equation is based on work by J-E Ståhl and gives better surface estimates often indicating potential to increase feeds compared to other estimates.

Table A. Data according to refined estimate R_a equation

Surface finish R_a value (μm)	Nose radius, r_c (mm)					
	0,2	0,4	0,8	1,2	1,6	2,4
	Feed rate, f (mm/rev)					
0,6	0,06	0,08	0,12	0,14	0,17	0,21
1,6	0,10	0,14	0,20	0,24	0,28	0,34
3,2	0,14	0,20	0,28	0,34	0,39	0,48
6,3	–	0,27	0,39	0,48	0,55	0,68
8,0	–	–	0,44	0,54	0,63	0,77

In SMG v2 classification of workpiece materials involves a specific material standard in a specific condition assigned as reference for easy and unambiguous adjustment of cutting data for any actual material compared to any Seco reference material. As examples the reference materials EN C45E for SMG P4 and EN 42 CrMo 4 for both SMG P5 and SMG H5 shown below in table 1 where the reference level material property is indicated. (A more complete extract can be found on page(s) 50, 688

SMG	Description	Properties	Reference	SMG	Description	Properties	Reference
P4	Low alloy general structural steels, 0.25% < C < 0.67%wt Low alloy Quench & Temper steels	520 < R _m < 1200	C 45E R _m = 660 N/mm ²	H5	Quenched & Tempered steels	38 < HRC < 56	42 CrMo 4 50 HRC
P5	Structural steels, 0.25% < C < 0.67%wt Quench & Temper steels	550 < R _m < 1200	42 CrMo 4 R _m = 700 N/mm ²				

Focusing specifically on EN 42 CrMo 4 in annealed condition, the ultimate tensile strength R_m may typically vary between R_m = 630 N/mm² and R_m = 780 N/mm², which provide a reference level for SMG P5. In Quenched & Tempered condition, the ultimate tensile strength R_m may typically be between R_m = 900 N/mm² and R_m = 1100 N/mm² thus still belongs to SMG P5. However, if hardened above R_m = 1200 N/mm² it instead belongs to SMG H5.

SMG	EN	W-Nr	AFNOR	BS	UNI	JIS	AISI / ASTM	GOST	Condition	R _{m,nom}	HRC _{nom}
P5	42 CrMo 4	1.1201	42 CD 4	708 M 40	42 CrMo 4	SCM 440 (H)	4142, 4140	38HM	Annealed	700	
	42 CrMo 4	1.1201	42 CD 4	708 M 40	42 CrMo 4	SCM 440 (H)	4142, 4140	38HM	Quenched & Tempered	1000	
H5	42 CrMo 4	1.1201	42 CD 4	708 M 40	42 CrMo 4	SCM 440 (H)	4142, 4140	38HM	Quenched & Tempered		45
	42 CrMo 4	1.1201	42 CD 4	708 M 40	42 CrMo 4	SCM 440 (H)	4142, 4140	38HM	Quenched & Tempered		50

The EN 42CrMo4 quench & tempered steel could be used to illustrate the machinability dependence of materials' condition.

The graphs below indicate how speed recommendations for a nominal conditions may be adjusted for relative R_m (left diagram valid for ISO-P) and for relative HRC (valid for ISO-H).

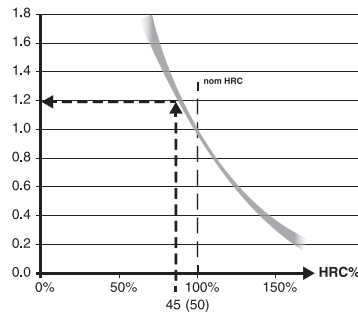
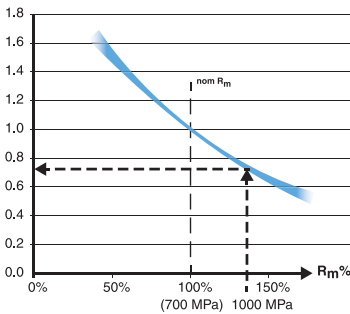

To further illustrate how the SMG v2 SMG P5 nominal v_c can be adjusted to a more accurate recommended v_c we need ultimate tensile strength R_m data and in this case we use the EN 42 CrMo 4 quenched & tempered to R_m = 1000 N/mm² according to above table (bold blue arrows).

Assume that we find that the SMG P5 nominal v_c = 280 m/min for a certain product and machining.

Then, actual recommended v_c = 280 m/min x 0,75 = 210 m/min.

Consequently in the SMG H5 the nominal v_c can be adjusted using the hardened EN 42 CrMo 4 at HRC 45 (smaller grey arrows).

Assume that the SMG H5 nominal v_c = 50 m/min for a certain product and machining using a coated cemented carbide tools then, actual recommended v_c = 50 m/min x 1,2 = 60 m/min.

Note that when using PCBN tools cutting data recommendation starts at page(s) 78.

For further workpiece material details please see page(s) 688 and suggested cutting data at applicable pages.

For more convenient cutting data handling we recommend applicable tools in My Pages – Suggest on www.secotools.com

Extract from Workpiece materials classification on page(s) 688

Steels, ferritic and martensitic stainless steels

SMG	Description	Properties	Reference
P1	Free-cutting steels	$360 < R_m < 880$	11 SMn30 $R_m = 385 \text{ N/mm}^2$
P2	Low alloy ferritic steels, $C < 0.25\% \text{wt}$ Low alloy weldable general structural steels	$320 < R_m < 600$	S235JRG2 $R_m = 420 \text{ N/mm}^2$
P3	Ferritic & ferritic/pearlitic steels, $C < 0.25\% \text{wt}$ Weldable general structural steels Case hardening steels	$430 < R_m < 610$	16 MnCr 5 $R_m = 550 \text{ N/mm}^2$
P4	Low alloy general structural steels, $0.25\% < C < 0.67\% \text{wt}$ Low alloy Quench & Temper steels	$520 < R_m < 1200$	C 45E $R_m = 660 \text{ N/mm}^2$
P5	Structural steels, $0.25\% < C < 0.67\% \text{wt}$ Quench & Temper steels	$550 < R_m < 1200$	42 CrMo 4 $R_m = 700 \text{ N/mm}^2$
P6	Low alloy through hardening steels, $C > 0.67\% \text{wt}$ Low alloy spring and bearing steels	$520 < R_m < 1200$	C 100S $R_m = 600 \text{ N/mm}^2$
P7	Through hardening steels, $C > 0.67\% \text{wt}$ Spring and bearing steels	$600 < R_m < 1200$	100 Cr 6 $R_m = 650 \text{ N/mm}^2$
P8	Tool steels High Speed Steels (HSS)	$600 < R_m < 1200$	X 40 CrMoV 5 1 $R_m = 700 \text{ N/mm}^2$
P11	Ferritic & martensitic stainless steels	$415 < R_m < 1200$	X 20 Cr 13 $R_m = 675 \text{ N/mm}^2$

Hard materials

SMG	Description	Properties	Reference
H3	Case hardened steels	$58 < \text{HRC} < 62$	16 MnCr 5 60 HRC
H5	Quenched & Tempered steels	$38 < \text{HRC} < 56$	42 CrMo 4 50 HRC
H7	Quenched & Tempered steels Bearing steels	$56 < \text{HRC} < 64$	100 Cr 6 60 HRC
H8	Tool steels High Speed Steels	$38 < \text{HRC} < 64$	X 40 CrMoV 5 1 50 HRC
H11	Martensitic stainless steels	$38 < \text{HRC} < 50$	X 20 Cr 13 45 HRC
H12	Precipitation hardened stainless steels	$33 < \text{HRC} < 50$	X 5 CrNiCuNb 16 4 35 HRC
H21	Manganese steels	$23 < \text{HRC} < 64$	X 120 Mn 12 50 HRC
H31	White cast irons	$50 < \text{HRC} < 64$	EN-GJN-HV600(XCr11) 55 HRC

Cutting speed v_c (m/min)

In this section a recommended cutting speed is indicated under specified conditions and a selected SMG (ver.2)

Use the tables beginning on page(s) 688 to classify the workpiece material into a SMG.

In order to increase the accuracy towards the actual cutting conditions and requirements of the applications the recommendation is to use My Pages – Suggest on www.secotools.com

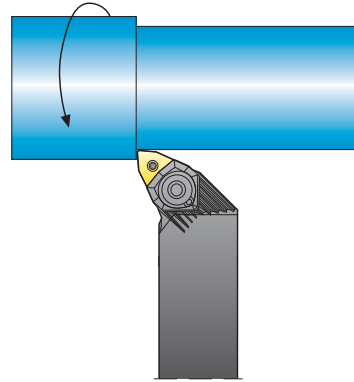

κ_r = cutting edge angle (°) (from holder)

r_n = nose radius (mm)

a_p = depth of cut (mm)

f = feed rate (mm/rev)

Universal insert: CCMT09T304-MF2

Tool life = 15 min

$a_p = 1$ mm

Holder: SCLCL1212M09

SMG	TP1501			TP2501			TP3500			CP500		
	f (mm/r)			f (mm/r)			f (mm/r)			f (mm/r)		
	0,15	0,2	0,25	0,15	0,2	0,25	0,15	0,2	0,25	0,15	0,2	0,25
P1	820	750	700	680	640	600	610	550	510	295	265	250
P2	790	730	680	560	580	580	600	540	490	285	260	240
P3	530	530	520	580	600	590	420	380	340	245	225	210
P4	600	560	520	500	470	440	450	410	375	215	195	185
P5	445	445	435	410	425	425	355	320	290	205	190	175
P6	640	600	550	540	500	475	485	440	400	230	210	195
P7	475	475	460	370	400	410	375	335	305	220	200	185
P8	445	445	435	410	425	425	355	320	290	205	190	175
P11	460	460	445	420	440	435	365	325	295	215	195	180

Universal insert: CCMT09T304-MF2

Tool life = 15 min

$a_p = 1$ mm

Holder: SCLCL1212M09

SMG	TP1030			TP1020		
	f (mm/r)			f (mm/r)		
	0,1	0,2	0,3	0,1	0,2	0,3
P1	550	445	360	350	235	170
P2	540	430	355	340	230	165
P3	465	370	305	295	195	145
P4	410	325	270	260	170	125
P5	390	310	255	245	165	120
P6	440	350	285	280	185	135
P7	415	330	270	260	175	130
P8	390	310	255	245	165	120
P11	400	320	265	255	170	125

Universal insert: CNMG120408-M3
Tool life = 15 min
 $a_p = 2,5$ mm
Holder: DCLNR2525M12-M

SMG	TP0501			TP1501			TP2501			TP3500			TP200		
	f (mm/r)			f (mm/r)			f (mm/r)			f (mm/r)			f (mm/r)		
	0,2	0,3	0,4	0,2	0,3	0,4	0,2	0,3	0,4	0,2	0,3	0,4	0,2	0,3	0,4
P1	780	690	610	690	590	510	590	510	450	510	405	335	335	290	255
P2	760	670	590	680	570	495	560	520	460	490	395	330	330	280	250
P3	620	590	510	500	450	400	570	530	465	345	275	225	280	240	215
P4	580	510	450	510	435	375	435	375	330	375	300	250	250	210	190
P5	520	495	435	420	380	335	405	375	330	290	230	190	235	205	180
P6	620	550	480	550	465	405	465	405	355	400	320	265	265	230	200
P7	550	520	460	445	405	355	390	380	350	305	245	200	250	215	190
P8	520	495	435	420	380	335	405	375	330	290	230	190	235	205	180
P11	540	510	445	435	390	345	420	385	340	295	235	195	245	210	185

Universal insert: CNMG190616-MR7
Tool life = 15 min
 $a_p = 6$ mm
Holder: DCLNR4040R19-M

SMG	TP0501			TP1501			TP2501			TP3500			TP40		
	f (mm/r)			f (mm/r)			f (mm/r)			f (mm/r)			f (mm/r)		
	0,4	0,55	0,7	0,4	0,55	0,7	0,4	0,55	0,7	0,4	0,55	0,7	0,4	0,55	0,7
P1	590	480	400	490	405	340	435	365	315	320	245	195	235	190	155
P2	570	465	385	480	395	335	440	350	285	310	235	190	230	185	155
P3	490	375	290	385	310	250	450	355	285	210	160	125	195	155	130
P4	430	355	295	360	295	250	320	270	230	235	180	145	170	140	115
P5	415	315	245	320	260	210	315	245	195	175	135	105	165	130	110
P6	465	380	315	390	320	270	345	290	250	250	195	155	185	150	125
P7	435	335	260	340	275	225	335	275	225	190	140	115	175	140	115
P8	415	315	245	320	260	210	315	245	195	175	135	105	165	130	110
P11	425	325	250	330	265	220	325	255	200	180	140	110	170	135	115

Universal insert: CNMG120408-MF2
Tool life = 15 min
 $a_p = 1,5$ mm
Holder: DCLNR2525M12-M

SMG	TH1000			TH1500		
	f (mm/r)			f (mm/r)		
	0,1	0,25	0,4	0,1	0,25	0,4
H3	90	70	55	125	80	60
H5	170	125	100	230	150	110
H7	90	70	55	125	80	60
H8	170	125	100	230	150	110
H11	215	160	130	295	195	140
H12	350	260	205	—	—	—
H21	170	125	100	—	—	—

Universal insert: CCMT09T308-MF2
Tool life = 10 min
 $a_p = 1$ mm
Holder: C4-SCLCR-13080-09

SMG	TM4000			CP500			TP3500		
	f (mm/r)			f (mm/r)			f (mm/r)		
	0,1	0,2	0,3	0,1	0,2	0,3	0,1	0,2	0,3
M1	390	335	290	430	335	255	410	370	305
M2	315	270	235	350	270	205	335	300	245
M3	240	205	180	265	205	155	255	230	185
M4	180	155	135	200	155	115	190	170	140
M5	150	130	110	165	130	95	160	140	115

Universal insert: CNMG120408-MF4

Tool life = 10 min

$a_p = 2$ mm

Holder: PCLNL2020K12JETL

SMG	TM2000			TM4000			CP500			TP2500		
	f (mm/r)			f (mm/r)			f (mm/r)			f (mm/r)		
	0,2	0,3	0,4	0,2	0,3	0,4	0,2	0,3	0,4	0,2	0,3	0,4
M1	335	300	270	325	275	240	305	215	160	510	395	305
M2	270	240	215	260	220	190	245	170	125	410	320	250
M3	205	185	165	200	170	145	185	130	95	310	245	190
M4	155	135	125	150	125	110	140	100	75	235	185	140
M5	130	115	105	125	105	90	115	80	60	195	150	120

Universal insert: CCMT09T308-M5

Tool life = 15 min

$a_p = 1$ mm

Holder: C4-SCLCL-17090-09

SMG	TK1001			TK2001			TP0500		
	f (mm/r)			f (mm/r)			f (mm/r)		
	0,2	0,3	0,4	0,2	0,3	0,4	0,2	0,3	0,4
K1	600	560	520	550	500	465	400	355	325
K2	465	435	415	465	430	410	350	310	285
K3	395	365	350	390	365	345	295	260	240
K4	375	350	335	375	345	330	280	250	230
K5	225	210	200	225	205	195	165	150	135
K6	375	340	320	340	310	285	250	220	200
K7	285	265	255	285	265	250	215	190	175

Universal insert: CNMG120412-MR7

Tool life = 15 min

$a_p = 3$ mm

Holder: A40U-PCLNL12

SMG	TK1001			TK2001			TP0500		
	f (mm/r)			f (mm/r)			f (mm/r)		
	0,2	0,35	0,5	0,2	0,35	0,5	0,2	0,35	0,5
K1	550	485	445	500	425	375	360	300	260
K2	430	385	360	425	380	350	310	260	225
K3	365	330	305	360	320	300	265	220	190
K4	345	315	290	345	305	285	250	210	185
K5	205	185	175	205	185	170	150	125	110
K6	340	300	275	310	260	230	220	185	160
K7	265	240	220	265	235	215	190	160	140

Universal insert: CCGT060204F-AL

Tool life = 15 min

$a_p = 1$ mm

Holder: A10L-SCLCR06

SMG	KX		
	f (mm/r)		
	0,1	0,15	0,2
N1	610	540	495
N2	490	435	400
N3	330	290	265
N11	375	335	305

Universal insert: CCMT09T304-F1

Tool life = 10 min

$a_p = 1$ mm

Holder: C4-SCLCR-27050-09JET

SMG	TS2000			CP200			CP500		
	f (mm/r)			f (mm/r)			f (mm/r)		
	0,08	0,15	0,2	0,08	0,15	0,2	0,08	0,15	0,2
S1	90	70	60	48	40	36	42	35	32
S2	70	55	47	39	32	29	36	30	27
S3	60	47	40	33	28	25	31	26	24
S11	130	100	85	70	60	55	—	—	—
S12	100	75	65	55	44	41	—	—	—
S13	75	60	50	41	34	31	—	—	—

Universal insert: CNMG120408-MF1

Tool life = 10 min

$a_p = 1,5$ mm

Holder: PCLNL2525K12JETLB

SMG	TS2000			CP200			890			CP500		
	f (mm/r)			f (mm/r)			f (mm/r)			f (mm/r)		
	0,1	0,2	0,3	0,1	0,2	0,3	0,1	0,2	0,3	0,1	0,2	0,3
S1	80	55	43	44	35	31	40	33	28	38	31	27
S2	65	46	35	36	29	25	33	26	23	33	27	23
S3	55	39	30	31	25	21	28	23	20	29	23	20
S11	115	80	65	65	50	44	60	47	41	—	—	—
S12	90	65	48	49	39	34	45	36	31	—	—	—
S13	70	49	37	38	31	26	35	28	24	—	—	—

Universal insert: CNMG120408-MR4

Tool life = 10 min

$a_p = 3$ mm

Holder: C6-PCLNR-45065-12JETL

SMG	TS2500			883		
	f (mm/r)			f (mm/r)		
	0,2	0,3	0,45	0,2	0,3	0,45
S1	45	34	24	25	21	18
S2	37	27	20	20	17	14
S3	32	24	17	17	15	12
S11	65	49	35	36	30	26
S12	50	38	27	27	23	20
S13	39	29	21	21	18	15

Note: We recommend to use My Pages – Suggest on www.secotools.com, using accurate workpiece material classification, SMG (ver.2)

Introduction

Seco offers a range of small diameter boring bars to machine holes as small as 5,5 mm. Inserts are available in C and T shape.

The toolholders are available in steel and have the possibility for internal through coolant.

Set-up information

When positioned in the machine the insert will sit slightly above centre line. This is a design feature of the tool that compensates for the deflection and improves the machining operation.

When setting the tool in the machine be sure to position it with the flat parallel and in the same plane as the bed of the machine.

The boring bars can be used with or without the cylindrical toolholder sleeve.

Please see page(s) 342.

Position flat parallel
with machine bed

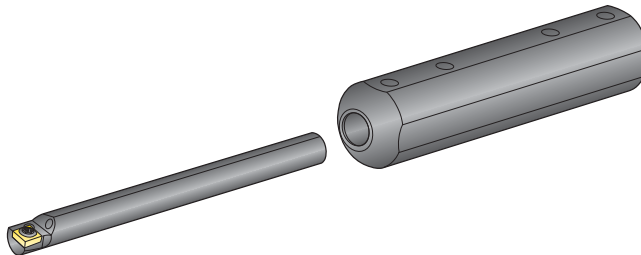
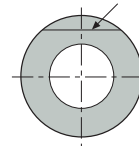

Introduction

Turning – Railway wheels

The product range consists of:

- Inserts for machining of new wheels
- Inserts for railway wheel re-turning (RWRT)
- Cassettes for railway wheel re-turning (RWRT)

Machining of new wheels

RCMX-R2, -RR94, -RR97



Strong geometries for machining at high feed rates.

Feed recommendation: 0,6-1,5 mm/rev
D.O.C. recommendation: $a_p < 15$ mm

SNMM-R7



For roughing operations at high feed rates and large depth of cut.

Feed recommendation: 0,6-1,2 mm/rev
D.O.C. recommendation: $a_p < 15$ mm

Inserts for railway wheel re-turning (RWRT)

LNMX-MF

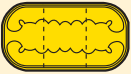

For re-machining at small depth of cut. (Normally used when machining with an under floor lathe.)

Feed recommendation: 0,4-1,0 mm/rev
D.O.C. recommendation: $a_p < 10$ mm

LNMX-MR

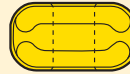

Basic choice for re-machining.

Feed recommendation: 0,6-2,0 mm/rev
D.O.C. recommendation: $a_p < 15$ mm

New inserts and geometries for railway wheel re-turning (RWRT)

LNMX19-R2



R2 – for less worn out, soft wheels for best chip control.

Feed recommendation: 0,40-1,10 mm/rev
D.O.C. recommendation: $a_p = 2-5$ mm

LNMX-RR94



RR94 – for the moderately damaged wheels.

D.O.C. and feed recommendation:
LNMX19, $a_p = 2-5$ mm; $f = 0,45-1,40$ mm/rev
LNMX30, $a_p = 2-10$ mm; $f = 0,55-1,80$ mm/rev

LNMX-RR97



RR97 – for the highly damaged wheels at high parameters.

D.O.C. and feed recommendation:
LNMX30, $a_p = 2-12$ mm; $f = 0,75-1,80$ mm/rev

SNMX-R2

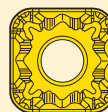

SNMX-R2 inserts can be economically used for less skidded or first time re-turned wheels.

D.O.C. and feed recommendation:
SNMX1911, $a_p = 2-5$ mm; $f = 0,75-1,80$ mm/rev

Cassettes for railway wheel re-turning RWRT

Standard products

CT-PLANR/L (R/L175.32)



Pin clamped cassettes for LNMX19 and LNMX30

Right-hand version shown

CT-PLFNR/L (R/L177.32-3219-19)



Pin clamped cassettes for LNMX19 and LNMX30

Right-hand version shown

CT-PSANR/L



Lever clamped cassettes for SNMX1911

Right-hand version shown

The cassettes are equipped with carbide shims for insert support and cassette protection.

The toolholders for these cassettes are machine specific. The combination cassettes are also machine specific. Some of them are offered as specials

Cutting speed, v_c (m/min)

Use the tables beginning in page(s) 688 to classify the workpiece material into a SMG
 Use the feed rate recommendation table in page(s) 56 to get a start value
 Formulae for cutting data calculation can be found in page(s) 47

v_c = cutting speed (m/min)

D.O.C = insert width (mm)

f = feed rate (mm/rev)

Universal insert: LNMX191940-RR94 Tool life = 60 min a_p = 8 mm Holder: CT-PLANL3223-19

SMG	TP0501			TP2501			TP200		
	f (mm/r)			f (mm/r)			f (mm/r)		
	0,6	0,9	1,2	0,6	0,9	1,2	0,6	0,9	1,2
P4	185	120	90	175	130	105	115	95	80

Universal insert: LNMX401432-RR93 Tool life = 60 min a_p = 5 mm Holder: PLBNR6060V40-A

SMG	TP0501			TP2501		
	f (mm/r)			f (mm/r)		
	0,6	1,0	1,4	0,6	1,0	1,4
P8	175	90	50	155	85	50

Universal insert: RCMX320900-R2 Tool life = 45 min a_p = 3 mm Holder: PRDCN5050T32

SMG	TP0501			TP2501		
	f (mm/r)			f (mm/r)		
	0,6	0,9	1,2	0,6	0,9	1,2
P7	250	160	110	210	150	110

Universal insert: RCMX250700-RR94 Tool life = 60 min a_p = 6 mm Holder: PRDCN4040S25

SMG	TP0501			TP2501			TP200			TP40		
	f (mm/r)			f (mm/r)			f (mm/r)			f (mm/r)		
	0,6	1	1,5	0,6	1	1,5	0,6	1	1,5	0,6	1	1,5
P4	205	125	75	190	135	95	125	95	80	95	60	41

Universal insert: SNMM250724-R7 Tool life = 45 min a_p = 3 mm Holder: PSBNR4040S25

SMG	TP0501			TP2501			TP3500			TP200		
	f (mm/r)			f (mm/r)			f (mm/r)			f (mm/r)		
	0,6	0,9	1,2	0,6	0,9	1,2	0,6	0,9	1,2	0,6	0,9	1,2
P4	265	190	145	230	180	145	170	120	90	140	115	100



Chipbreaking problems

Too long chips

Step 1. Increase the feed rate.

Step 2. Use the chart on page(s) 24 to select a more suitable chipbreaker. Take one to the left or below the one being used.

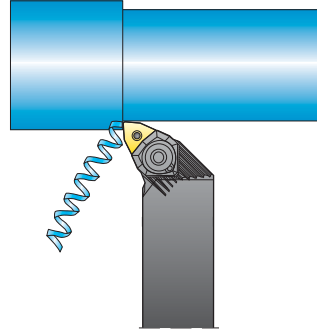

Too hard chipbreaking

Step 1. Reduce the feed rate.

Step 2. Use the chart on page(s) 24 to select a more suitable chipbreaker. Take one to the right or above the one being used.

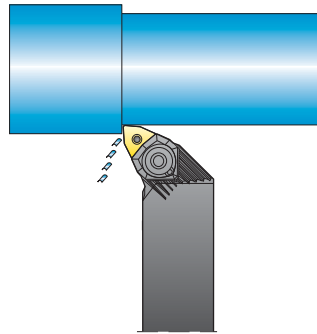

Vibrations

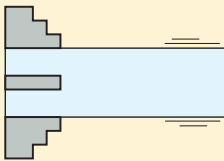

- Improve the stability of the tool and workpiece.
- Change the cutting speed.
- Increase the feed rate.
- Reduce the depth of cut.
- Select a more easy-cutting chipbreaker.
- Select a smaller nose radius.

Poor surface finish

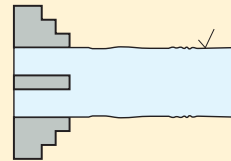

- Reduce the feed rate.
- Increase the cutting speed.
- Use a coolant.
- Improve the stability of the tool and workpiece.
- Select a more easy-cutting chipbreaker.
- Increase the nose radius.

Optimisation – Grades

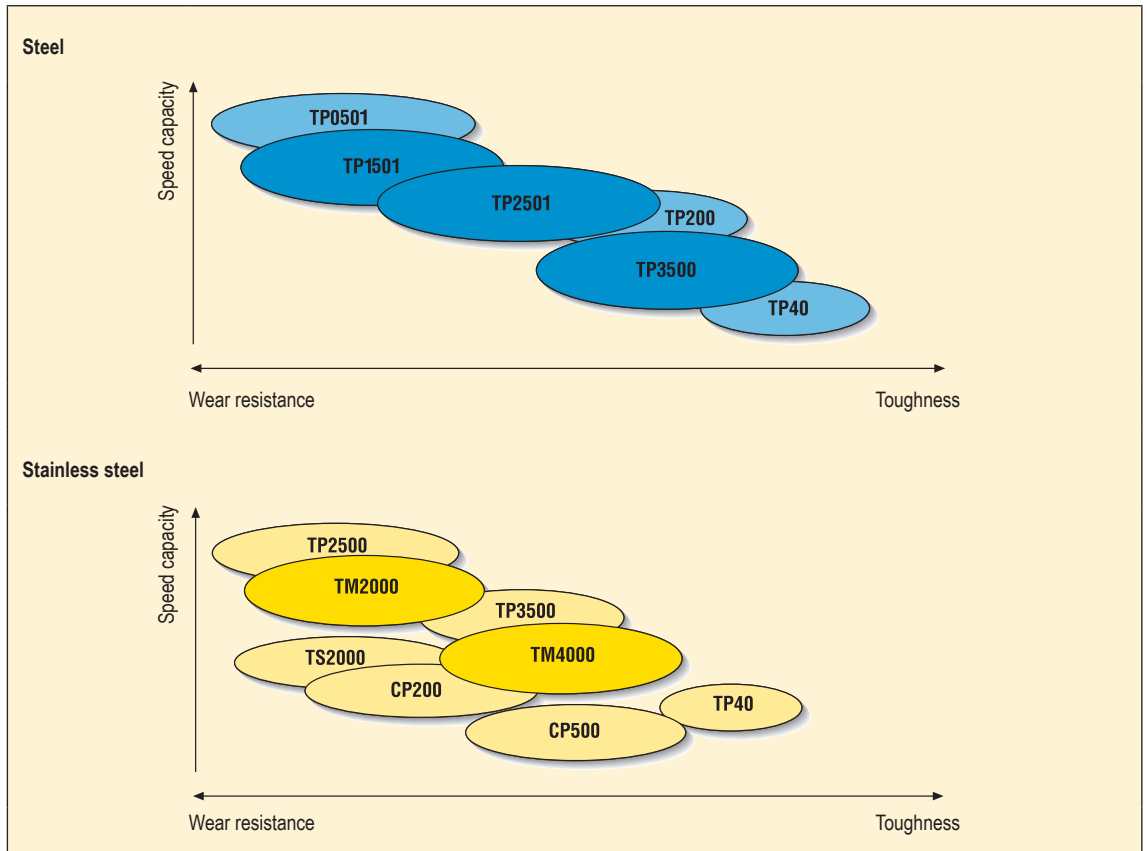

Optimisation – Wear

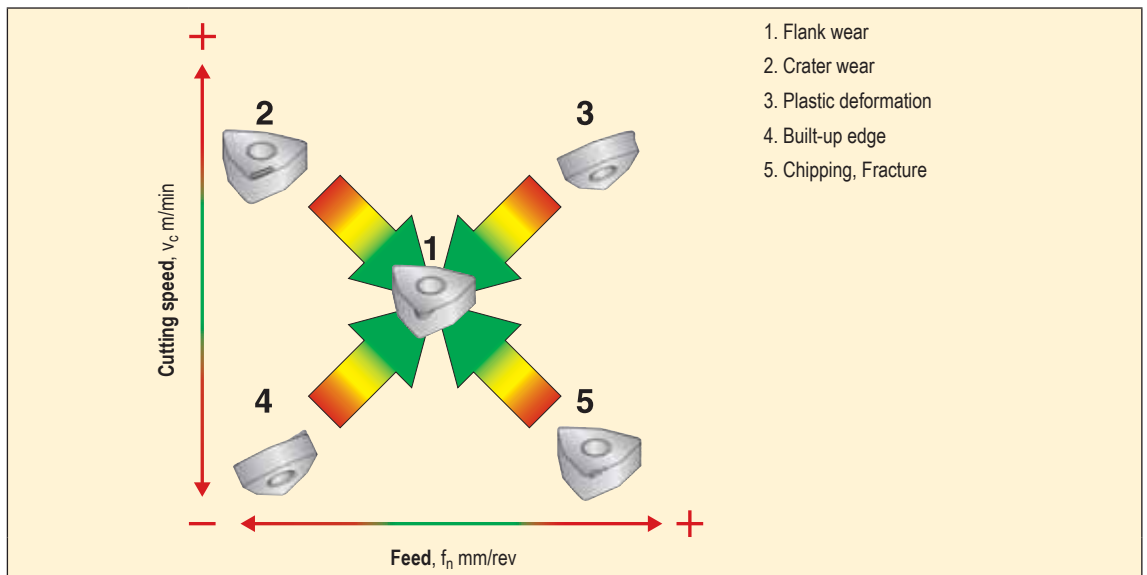

Flank wear

The normal flank wear, since it is uniform, predictable and dependable, is the most desirable wear mode.

Cause

Abrasive wear. Hard microscopic inclusions often of carbides at workpiece material surface in contact with insert cut into the insert. In some cases fractions of non-contained microscopic hard particles that cannot be retained in a matrix may tumble between surfaces in contact and also cut into the insert. A irregular flank wear that initially may look uniform as well as a too rapid uniform flank wear pre-maturely reach a set target wear criterion, require corrective action in some form.

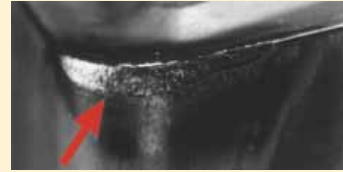

What to look for

- Relatively uniform abrasion along the cutting edge
- Non-uniform appearance may indicate influence of other wear modes (see other wear descriptions)

Note: Metal from the workpiece can be smeared over the cutting edge and can exaggerate the apparent size of the wear scar.

When to expect it

- In all materials, an insert will finally fail due to normal flank wear if it doesn't fail from something else first.

Corrective actions (to rapid flank wear)

- Select a more wear resistant, harder, or coated carbide grade
- Reduce the cutting speed (or RPM)
- Apply coolant correctly
- If possible, select insert with larger radius

Crater wear

Cause

A combination of chemical diffusion, decomposition and abrasive wear causes cratering. Classically the heat from workpiece chips decomposes the tungsten carbide grains in the substrate, and carbon leaches into the chips (diffusion), wearing a 'crater' on the top of the insert. The crater will eventually grow large enough to cause the insert to fail e.g. by chipping or rapid flank wear. Modern coating technology such as Duratomic® has reduced this wear mode drastically, but by achieving better performance by high cutting data it inevitably appears again.

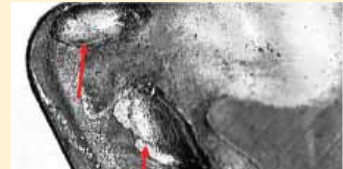

What to look for

- Craters or pits on top of inserts
- Chipbreaking may change to better or worse after cratering started

When to expect it

- Iron or titanium-based alloys

Corrective actions

- Use wear resistant grades and if needed try another grade with other coating design

Or reduce heat by...

- Use coolant
- Use a freer cutting geometry
- Reduce the cutting speed (or RPM)
- Change feed rate

Built-up edge

Cause

Material adhesion. Built-up edge (BUE) is a result of the workpiece material being pressure welded to the cutting edge. This could be an indicator of exit conditions from cutting in workpiece materials with high chemical affinity, high cutting forces/pressure, and locally insufficient temperature around the cutting zone. The wear mode itself could in some cases even be beneficial for tool life, but the consequence of built-up edge breaks off and allows chips to bring pieces of the insert with it or acting as an indicator of chipping, notching or other discontinuous wear modes, makes it important.



What to look for

- Shiny material on the top or flank of the insert edge
- Erratic changes in part size or surface finish

When to expect it

- High temp alloys and stainless steel and other workpiece materials appearing 'gummy'
- At relatively low speeds especially at limited cuts e.g. facing to center & parting-off and even more apparent in the centre of a drill

Corrective actions

- Change of grade to other coating designs may reduce built-up edge.
- Increase the cutting speed (or RPM) or increase the feed rate
- Try an insert with a sharper cutting edge geometry
- Apply coolant correctly or not at all; perhaps do another check on the emulsion concentration

Chipping

Cause

Mechanical instability or material adhesion. Chipping of the insert edge could be a result of vibrations in the workpiece or spindle. Larger hard inclusions in the material being cut and interrupted cuts may result in local stress concentrations that can cause chipping. In addition adhered material may cause a tensile stress that on removal can tear off parts of an insert.

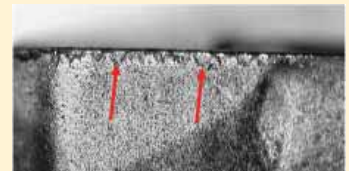

What to look for

- Chippings along the edge of the insert

When to expect it

- Non-rigid set-ups (bad bearings, worn spindles, etc.)
- Demanding entrance and exit conditions
- Hard spots at well as soft spots in work materials
- Powder Metallurgically (PM) made materials

Corrective actions

- Ensure rigid machine tool setup
- Tougher insert grade or stronger cutting edge geometry
- Reduce the feed rate
- In some cases, turn-off the coolant
- See also corrective actions for built-up edge

Thermo mechanical failure

Cause

A combination of thermal cycling (frequency changing the working temperature for the insert rapidly), thermal load (amount of heat), thermal shock (fast temperature change from warm to cold and the other way around in different zones), and mechanical shock (stress change from release to full load) causes thermo mechanical failure. Stress cracks form along the insert edge, eventually causing sections of carbide to pull out and appear to be chipping. Seen most commonly in milling.

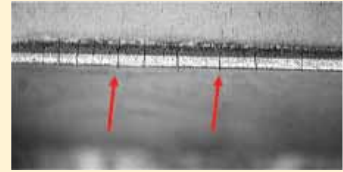

What to look for

- Multiple cracks perpendicular to cutting edge
- Irregular chipping on edges or wear spots on rake face

When to expect it

- Intermittent cuts e.g. facing over slots, but also tool paths when machining a large number of parts creating the thermal cycling or intermittence in coolant flow

Corrective Actions

- Apply coolant differently or not at all
- Select a tougher grade
- Reduce the cutting speed (or RPM) or reducing the feed rate
- Use a free-cutting geometry or chipbreaker to reduce heat

Edge deformation

Cause

Thermal overloading. Excessive heat causes the carbide binder (cobalt) to soften. It could come in combination with mechanical overloading where the pressure of the insert against the workpiece all in all making an insert edge deform partly or fully, eventually breaking off or leading to irregular flank wear.



What to look for

- Deformation at the cutting edge or excessive irregular flank wear
- The dimensions of the workpiece may change drastically

When to expect it

- High speed and/or high feed rates
- Hard steels or work-hardened surfaces
- High temperature superalloys or stainless steels

Corrective actions

- Apply coolant correctly
- Try a harder, more wear resistant grade
- Reduce cutting speed (or RPM) or reduce the feed rate
- Select an insert with other geometric features

Notching

Cause

Combinations of local properties in workpiece materials and cutting conditions. Notching is often caused by the conditions at the surface of the workpiece e.g. surface hardening from previous cuts, forged or cast surfaces, or surface scale. This causes the insert to wear more rapidly in that part of the cutting zone. Local stress concentration can also lead to notching as a result of the compressive stress along the cutting edge and lack of the same behind the cutting edge – the insert is particularly affected at the depth of cut.

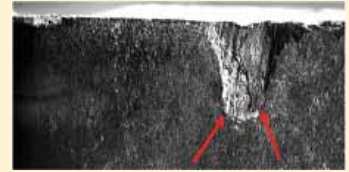

What to look for

- Notching or clusters of chippings for example at the depth of cut area on the insert

Note: The notch could be of two kinds; the smoother which indicate more chemical/abrasive interaction or the irregular more mechanical/adhesive extensive chipping.

When to expect it

- Materials with surface scale or oxidation
- Work hardening materials
- Cast or other process affected surfaces

Corrective actions

- Vary the depth of cut
- Adjust the feed rate or increase cutting speed
(NOTE: This will generate more flank wear)
- Select a tougher insert grade
- Exchange chipbreaker design drastically
- Prevent built-up edge

Mechanical fracture

Cause

Excessive load (also caused by other wear modes than finally) can cause mechanical fracture. Mechanical overload could of course cause the insert to break from the first moments in a cut to the exit or even after the release from cut. To be considered are also surrounding cutting conditions such as the conditions of the shim, workpiece clamping or machine condition.

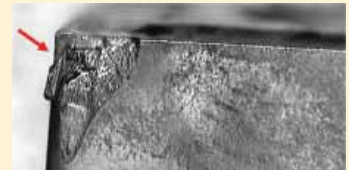

What to look for

- Fracture of insert (e.g. appearing as irregular flank wear often at the insert radius)
- Sudden increase of cutting force level

When to expect it

- Inhomogeneous workpieces e.g. with major inclusions, pores or design features that cause heavy impact or load release
- Unstable cutting conditions
- Low cutting data especially cutting speed

Corrective actions

- Reduce the feed rate or the depth of cut
- Increase speed
- Verify set-up rigidity
- Select a tougher insert grade or a more secure insert or cutting edge
- If possible reduce workpiece's inclusions and difficult geometrical features

Introduction

Polycrystalline Cubic Boron Nitride (PCBN) is a material which is sintered at extremely high pressure and high temperature into a wear-resistant material with properties close to those of diamond. Due to the hot hardness, oxidation resistance and fracture toughness of the material, inserts made of PCBN have excellent edge strength and long tool life when machining hard ferrous materials and pearlitic grey cast iron.

Secomax™ PCBN inserts are suitable for machining:

- Hardened steel (including hard-facing alloys)
- Pearlitic grey cast iron
- Chilled and white cast iron
- Manganese steel
- Cemented carbide
- Valve seat materials
- Powder Metallurgy (PM) alloys
- Nickel-based superalloys e.g. Inconel 718

For more information including a comprehensive guide to understanding and applying PCBN successfully, please ask your sales representative for the Secomax™ PCBN, Technical Guide (available in English).

Selection of insert types

Solid insert



According to the geometry, two sides can be used.

Grades:
CBN060K, CBN100, CBN010
CBN170, CBN200,
CBN300, CBN300P,
CBN400C, CBN500, CBN600

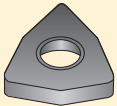

Toolholder styles:
D, P, C and M

CBN060K and CBN300 are also, in some geometries, available with hole.

Sintered layer insert -LF

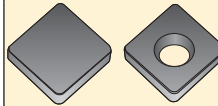

CBN layer sintered on to carbide. One side is usable.

Grades:
CBN10, CBN150, CBN010
CBN060K, CBN160C, CBN200
Toolholder styles: S, C and M

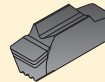

MDT
Grades:
CBN10, CBN010
CBN170, CBN200
Toolholder styles: C (MDT)

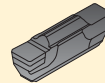

Brazed tip -L1 (single and double sided) and -L2

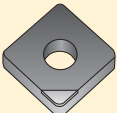

CBN brazed onto standard carbide inserts.

Grades:
CBN10, CBN010,
CBN060K, CBN150,
CBN160C, CBN170, CBN200

Toolholder styles:
D, P, S and M

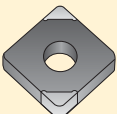
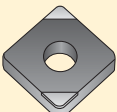

Brazed tip -L0

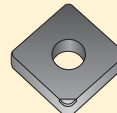

CBN brazed onto standard carbide inserts.

Grades:
CBN10

Toolholder styles:
D, P, S and M

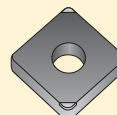

Geometry recommendations

Strong cutting edge geometries are always preferred.

- Negative cutting geometry
- Chamfered cutting edge
- Large nose radius

Sharp positive cutting edge geometry can be advantageous when:

- Finishing of small hardened bores without interruptions
- Finishing of unstable components without interruptions
- Finishing of pearlitic grey cast iron

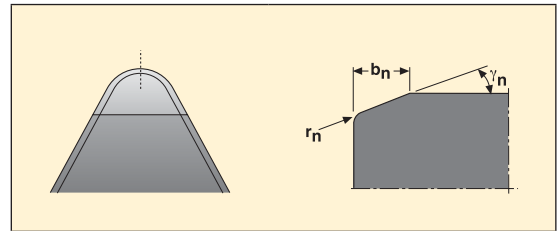

b_n = Chamfer width
 γ_n = Chamfer angle
 r_n = Hone radius

Edge preparation

- E** = Honed
- E25** = Extra honed, intended for Nickel-based superalloys
- S** = Chamfered and honed
- S25** = Chamfered and extra honed intended for PM material
- WZ** = High Feed (Wiper) geometry
- WZP** = High Feed (Wiper) geometry Positive
- WZN** = High Feed (Wiper) geometry Negative

Chamfer size and angle

Solid CBN inserts

- CBN060K** = 0,15 mm x 25°
- CBN010** = 0,10 mm x 20°
- CBN100** = 0,10 mm x 20°
- CBN200** = 0,20 mm x 20°
- CBN300** = 0,20 mm x 20°
- CBN400C** = 0,20 mm x 20°
- CBN500** = 0,20 mm x 20°
- CBN600** = 0,20 mm x 20°
- S-04015** = 0,40 mm x 15°
- X-05015** = 0,50 mm x 15°

Design

- LF** = Complete top layer
- B** = Brazed tips (single sided), Insert geometry C, D and V
- C** = Brazed tips (single sided), Insert geometry T and W
- D** = Brazed tips (single sided), Insert geometry S
- U** = Brazed tips (double sided), Insert geometry C, D and V
- V** = Brazed tips (double sided), Insert geometry T and W

Brazed CBN inserts CBN010, CBN10

- L0** = 0,10 mm x 20°
- L1** = 0,10 mm x 20°
- L2** = 0,20 mm x 20°
- LF** = 0,10 mm x 20°
- LF-MDT** = 0,10 mm x 25°

Brazed CBN inserts CBN200

- L1** = 0,20 mm x 20° (L1-WZ = 0,10mm x 20 °)
- L2** = 0,20 mm x 20°
- LF** = 0,20 mm x 20°
- LF-MDT** = 0,10 mm x 25°

CBN150

- L1** = 0,15 mm x 25°
(positive C-lock inserts, 0,10 mm x 20°)
- LF** = 0,15 mm x 25°

CBN160C, CBN060K

- L1** = 0,15 mm x 25°
- LF** = 0,15 mm x 25°

PCBN Chipbreaker inserts

The laser machined chipbreaker comes in two different styles, one for low and one for high feed applications. The non-wiper Secomax™ chipbreaker insert makes it possible to have a good chip control when low feed rates are used. The wiper Secomax™ chipbreaker insert provides improved chip control when using high feed rates.

Secomax™ PCBN, non-wiper chipbreaker inserts

Turning recommendation

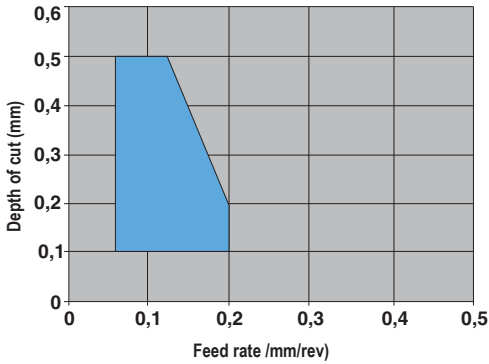

Secomax™ PCBN, wiper chipbreaker inserts

Turning recommendation

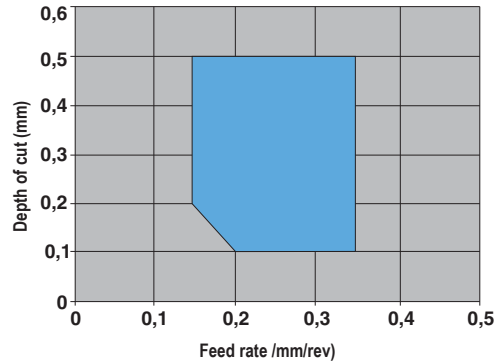

Laser machining provides several benefits over conventional production technologies such as grinding. Laser technology meets the highest requirements regarding dimensional accuracy, geometrical precision and surface quality for the machining of complex, three-dimensional geometries. These advantages and possibilities have led to a complex formed chipbreaker with “bumps” that would have been impossible to produce with any other production technology.



Plunge Turning

The vast majority of heat treated components in the metalworking industry are machined to their final geometrical form after hardening. Seco have developed a method in hard turning, the Seco patented Plunge Turning.

The plunging process consists of an orthogonal cut, using the solid CBN100, CBN010 or CBN060K. Using the Plunge Turning method gives two great advantages compared to conventional hard turning, reduction in cutting time (up to 90%) and improved surface integrity.

Conventional Turning

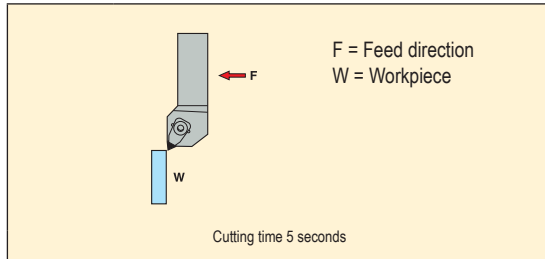

Plunge Turning

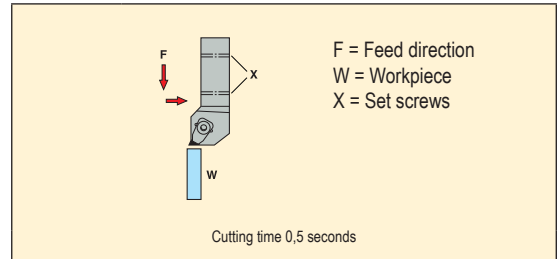

General cutting data recommendation for Plunge Turning is $v_c = 200-400$ m/min and $f = 0,04$ mm/rev. To avoid the cutting edge profile affecting surface finish, complete the operation with a small axial movement.

In addition to the introduction of the Plunge Turning method there are also some standard toolholders. These toolholders have set screws which give the possibility to adjust the toolholder to an exact setting angle. The toolholders have a designation ending with – PL, and are available for inserts in sizes T..11 and T..16.

Maximum depth of cut recommendations

Round inserts

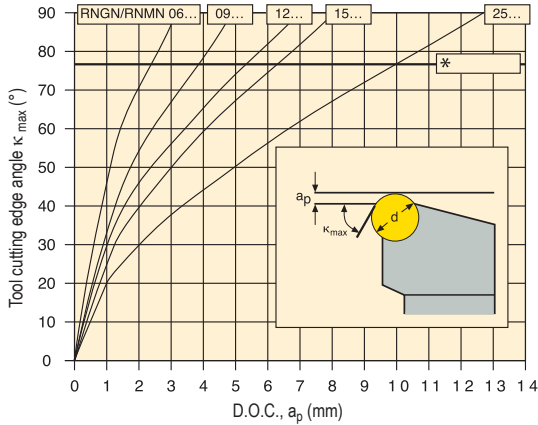

* = κ_{max} limited

The tool cutting edge angle is limited to 75° resulting in maximum depth of cut (a_p).

Max. D.O.C. a_p (mm)	Number of usable cutting edges/side at 80% utilization		
	R...06	R...09	R...12
0,10	20	24	–
0,15	16	20	23
0,20	14	17	20
0,25	12	15	18
0,30	11	14	16
0,40	10	12	14
0,50	8	10	12
0,80	7	8	10
1,00	6	7	9
1,20	5	7	8
1,50	5	6	7
1,80	4	5	6
2,00	4	5	6
2,50	3	4	5
3,00	3	4	5
3,50	–	4	4
4,00	–	3	4
4,50	–	–	4
5,00	–	–	3

Type	Grade	Max. D.O.C. a_p (mm)
L0	CBN10	0,5
L1	CBN060K	0,5
	CBN160C	0,5
	CBN170	0,5
	CBN10	0,5
	CBN010	0,5
	CBN150	0,5
L2	CBN10	0,5
	CBN010	0,5
LF	CBN160C	0,5
	CBN10	0,5
	CBN010	0,5
	CBN150	0,5
	CBN200	30% of cutting edge length
Solid	CBN100	0,5
	CBN010	0,5
	CBN060K	0,5
	CBN200	30% of cutting edge length
	CBN300	30% of cutting edge length
	CBN400C	30% of cutting edge length
	CBN500	30% of cutting edge length
	CBN600	30% of cutting edge length

MDT			
Type	Grade	Max. D.O.C. a_p (mm)	
	-LF	CBN10	0,5
		CBN010	
		CBN170	
		CBN200	
	M0-LF	CBN10	1,5
		CBN010	
		CBN170	
		CBN200	

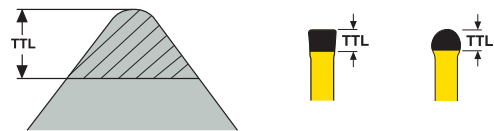

True tip length (TTL) in mm per nose radius (r_n) and tip type

Insert shape	Nose angle	$r_n = 0,4 \text{ mm}$			$r_n = 0,8 \text{ mm}$			$r_n = 1,2 \text{ mm}$	
		L0	L1	L2	L0	L1	L2	L0	L1
C	80°	1,4	2,7	–	1,2	2,4	–	1,6	2,2
D	55°	2,1	3,2	–	1,6	2,7	–	1,2	2,2
S	90°	–	–	–	1,1	2,2	–	–	–
T	60°	1,7	2,6	–	1,3	2,2	–	0,9	1,8
V	35°	2,7	–	5,1	1,7	–	4,2	–	–

MDT size	..-LF	..M0-LF
LC..13..	2,2	2,4
LC..1304..	2,4	2,4

MDT size	..LF	..M0-LF
LC..1603..	2,5	2,5
LC..1604..	2,5	3,1
LC..1605..	2,8	3,1
LC..1606..	3,2	3

The Secomax™ PCBN range of grades consists of both coated and uncoated grades.

The application areas for the Secomax™ grades are shown below.

The black areas in the chart indicate a grade's main ISO application groups and the white areas indicate other supplementary application groups.

Uncoated grades:

- CBN010
- CBN10
- CBN100
- CBN150
- CBN170
- CBN200
- CBN300
- CBN500
- CBN600

PVD coated grades:



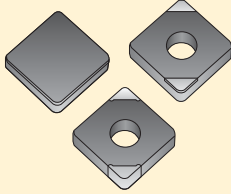
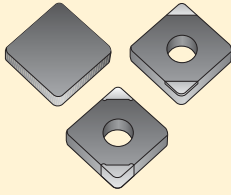
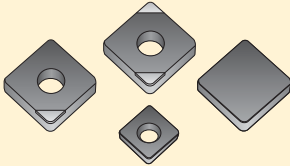
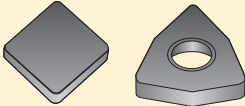
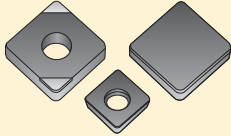
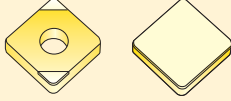

- CBN060K
- CBN160C
- CBN300P
- CBN400C

	P					M				K					N				S				H					
	P01 P10 P20 P30 P40 P50	M01 M10 M20 M30 M40	K01 K10 K20 K30 K40	N01 N10 N20 N30	S01 S10 S20 S30	H01 H10 H20 H30																						
CBN010																												
CBN10																												
CBN100																												
CBN150																												
CBN170																												
CBN200																												
CBN300																												
CBN500																												
CBN600																												
CBN060K																												
CBN160C																												
CBN300P																												
CBN400C																												

Grades

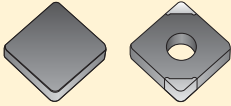
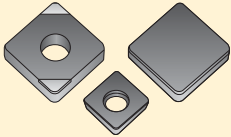
<p>CBN010</p> 	<p>Format: Solid, full-face brazed layer and brazed tips (single and double sided).</p> <p>Composition: 50% cBN content grade with an average grain size of 2 µm and a TiC ceramic binder.</p> <p>Coating: No coating.</p>
<p>CBN060K</p> 	<p>Format: Solid, full-face brazed layer and brazed tips (single and double sided).</p> <p>Composition: 60% cBN content grade with an average grain size of 1-2 µm and a TiCN ceramic binder.</p> <p>Coating: (Ti, Si, Al)N coating.</p>
<p>CBN10</p> 	<p>Format: Full-face brazed layer and brazed tips (single sided).</p> <p>Composition: 50% cBN content grade with an average grain size of 2 µm and a TiC ceramic binder.</p> <p>Coating: No coating.</p>
<p>CBN100</p> 	<p>Format: Solid.</p> <p>Composition: 50% cBN content grade with an average grain size of 2 µm and a TiC ceramic binder.</p> <p>Coating: No coating.</p>
<p>CBN150</p> 	<p>Format: Full-face brazed layer and brazed tips (single sided).</p> <p>Composition: 45% cBN content grade with an average grain size of < 1 µm and a TiCN ceramic binder.</p> <p>Coating: No coating.</p>
<p>CBN160C</p> 	<p>Format: Full-face brazed layer and brazed tips (single sided).</p> <p>Composition: 65% cBN content grade with an average grain size of < 1 µm and a TiCN ceramic binder.</p> <p>Coating: (Ti, Si)N coating.</p>

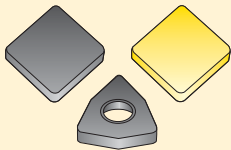
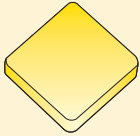
Grades

<p>CBN170</p> 	<p>Format: Full-face brazed layer and brazed tips (double sided).</p> <p>Composition: 65% cBN content grade with an average grain size of 2 µm and a TiCN+SiCw ceramic binder.</p> <p>Coating: No coating.</p>
<p>CBN200 (Tipped and Full-face)</p> 	<p>Format: Full-face brazed layer and brazed tips (single sided).</p> <p>Composition: 85% cBN content grade with an average grain size of 2 µm and a Co-W-Al ceramic binder.</p> <p>Coating: No coating.</p>
<p>CBN200 (Solid)</p> 	<p>Format: Solid.</p> <p>Composition: 90% cBN content grade with an average grain size of 3-6 µm and a Al ceramic binder.</p> <p>Coating: No coating.</p>
<p>CBN300, CBN300P</p> 	<p>Format: Solid.</p> <p>Composition: 90% cBN content grade with an average grain size of 22 µm and a Al ceramic binder.</p> <p>Coating: CBN300: No coating. CBN300P: (Ti, Al)N coating.</p>
<p>CBN400C</p> 	<p>Format: Solid.</p> <p>Composition: 90% cBN content grade with an average grain size of 3-6 µm and a Al ceramic binder.</p> <p>Coating: (Ti, Si)N coating.</p>
<p>CBN500</p> 	<p>Format: Solid.</p> <p>Composition: 90% cBN content grade with an average grain size of 15 µm and a AlN ceramic binder.</p> <p>Coating: No coating.</p>

Grades, PCBN

CBN600

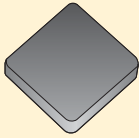

Format:
Solid.

Composition:
90% cBN content grade with multi modal grain size and AlN ceramic binding.

Coating:
No coating.

Cast Irons

SMG	Properties	Reference	Recommendations
K1	Grey cast irons (GCI)	EN-GJL-250	First choice in dry machining: CBN300. Universal option: CBN600. First choice when coolant is used: CBN200. First choice for finish machining: CBN400C. Adjust the depth of cut to get under the casting skin and blow holes.
K2	Compacted graphite irons (CGI)	EN-GJV-400	First choice for finish machining: CBN060K. First choice for rough machining: CBN300. Adjust the depth of cut to get under the casting skin and blow holes.
K4	Nodular cast irons (SGI)	EN-GJS-500-7	First choice for finish machining: CBN010.
K5	Austempered ductile irons (ADI)	EN-GJS-1000-5	First choice for finish machining: CBN010.

Superalloys and Titanium

SMG	Properties	Reference	Recommendations
S1	Iron based superalloys	Disalloy	First choice for finish machining: CBN010 with E25 edge preparation. Use coolant.
S2	Cobalt based superalloys	Stellite 21	First choice for finish machining: CBN010 with E25 edge preparation. Use coolant.
S3	Nickel based superalloys	Inconel 718	PCBN tools can be used on Inconel 718 with following properties. Solution annealed + age hardened Direct age hardened Hardness 32 – 44 Hrc First choice for finish machining: CBN170. Use coolant.

Hard Materials

SMG	Properties	Reference	Recommendations
H3	Case hardened steels	16 MnCr 5 60 HRC	<p>Dry machining is preferable. Coolant can be used. The chips should be fully annealed and brittle. First choice for finish machining: CBN060K. Universal grade for finish machining: CBN010. For high surface finish requirements, use CBN150.</p> <p>In interrupted machining: Moderate interruptions, use CBN060K/CBN010. Aggressive interruptions, use CBN160C/CBN150. Reduce the feed rate. Machine without coolant. If possible, chamfer any sharp edges of the workpiece before machining.</p>
H5	Quenched & Tempered steels	42 CrMo 4 50 HRC	<p>Dry machining is preferable. Coolant can be used. The chips should be fully annealed and brittle. First choice for finish machining: CBN060K. Universal grade for finish machining: CBN010. For high surface finish requirements, use CBN150.</p> <p>In interrupted machining: Moderate interruptions, use CBN060K/CBN010. Aggressive interruptions, use CBN160C/CBN150. Reduce the feed rate. Machine without coolant. If possible, chamfer any sharp edges of the workpiece before machining.</p>
H7	Quenched & Tempered steels Bearing steels	100 Cr 6 60 HRC	<p>Dry machining is preferable. Coolant can be used. The chips should be fully annealed and brittle. First choice for finish machining: CBN060K. Universal grade for finish machining: CBN010. For rough machining, use CBN200/CBN300. For high surface finish requirements, use CBN150.</p> <p>In interrupted machining: Moderate interruptions, use CBN060K/CBN010. Aggressive interruptions, use CBN160C/CBN150. Reduce the feed rate. Machine without coolant. If possible, chamfer any sharp edges of the workpiece before machining.</p>
H8	Tool steels High Speed Steels	X 40 CrMoV 5 1 50 HRC	<p>First choice for finish machining: CBN010. First choice for rough machining: CBN200. Interrupted machining of high speed steels can not be done.</p>
H11	Martensitic stainless steels	X 20 Cr 13 45 HRC	<p>First choice for finish machining: CBN010. First choice for rough machining: CBN300.</p> <p>In interrupted machining: Moderate interruptions, use CBN010. Aggressive interruptions, use CBN160C/CBN150.</p>
H21	Manganese steels	X 120 Mn 12 50 HRC	<p>First choice CBN300. When a tougher grade is needed use CBN500. Use chamfered inserts. Use stable toolholder and rigid clamping of the workpiece. Machine without coolant. Chamfer workpiece edges first.</p>
H31	White cast irons	EN-GJN- HV600(XCr11) 55 HRC	<p>Use CBN300 or when centerlock inserts are used CBN200. When a tougher grade is needed use CBN500. Universal option: CBN600. Adjust the depth of cut to get under the casting skin and blow holes. Dry machining is preferable.</p>

Other Difficult Materials

SMG	Properties	Reference	Recommendations
PM1	Low alloy PM materials	F-0008 Fe-0.7C	<p>PCBN tools can be used on PM parts as soft as 25 HRC. The critical parameter is particle hardness, when the particle hardness exceeds 50 HRC, PCBN is useful, no matter what the bulk hardness is.</p> <p>First choice CBN200. For rough machining CBN300 is an alternative. Use chamfered inserts, S25 edge preparation. Do not use coolant for interrupted cut.</p>
PM2	Medium alloy PM materials	FLC-4608 Fe2Cu1.8Ni0.5Mo0.2Mn0.8C	<p>PCBN tools can be used on PM parts as soft as 25 HRC. The critical parameter is particle hardness, when the particle hardness exceeds 50 HRC, PCBN is useful, no matter what the bulk hardness is.</p> <p>First choice CBN200. For rough machining CBN300 is an alternative. Use chamfered inserts, S25 edge preparation. Do not use coolant for interrupted cut.</p>
PM3	High alloy PM materials Exhaust valve seat materials		<p>First choice CBN150. Second choice CBN010. Use positive inserts. Use chamfered and honed edges for longer tool life. Use honed edges when tight tolerances are required. Machining can be carried out either with or without coolant.</p>
HF1	Hard facing alloys Welded or plasma deposited iron based alloys		<p>Cr-based alloys – Hardness <60 HRC. Co-based alloys – Hardness >35 HRC. Ni-based alloys – Hardness >35 HRC. Fe-based alloys – Hardness >35 HRC.</p> <p>First choice for finish machining: CBN010. First choice for rough machining: CBN300, or when centerlock inserts are used: CBN200. Use round inserts if possible. Use chamfered inserts. Adjust the depth of cut to get under the welding skin and blow holes. Dry machining is preferable. Remove any weld spatter before machining.</p>
HF2	Hard facing alloys Welded or plasma deposited cobalt and nickel based alloys		<p>Cr-based alloys – Hardness <60 HRC. Co-based alloys – Hardness >35 HRC. Ni-based alloys – Hardness >35 HRC. Fe-based alloys – Hardness >35 HRC.</p> <p>First choice for finish machining: CBN010. First choice for rough machining: CBN300, or when centerlock inserts are used: CBN200. Use round inserts if possible. Use chamfered inserts. Adjust the depth of cut to get under the welding skin and blow holes. Dry machining is preferable. Remove any weld spatter before machining.</p>
CC1	Sintered tungsten carbide	G50	<p>Sintered tungsten carbide with a Co content >17%.</p> <p>Basic conditions: Use CBN300. When a tougher grade is needed use CBN500. Use round inserts. Use chamfered inserts. Machining with coolant is preferable. Chamfer the workpiece at entry and exit.</p>

PCBN, Roughing a_p 0,5 – 3,0 mm

SMG	CBN200		CBN300		CBN400C		CBN500		CBN600	
	v_c	f	v_c	f	v_c	f	v_c	f	v_c	f
K1	500 – 1000	0,20 – 0,75	500 – 1500	0,20 – 0,80	600 – 1200	0,20 – 0,80	—	—	500 – 1200	0,20 – 0,75
K2	100 – 375	0,10 – 0,36	100 – 350	0,080 – 0,36	—	—	130 – 330	0,13 – 0,36	—	—
K5	100 – 450	0,10 – 0,24	—	—	—	—	—	—	—	—
H7	70 – 150	0,080 – 0,28	90 – 200	0,080 – 0,28	—	—	90 – 180	0,12 – 0,30	—	—
H8	50 – 150	0,030 – 0,22	50 – 150	0,050 – 0,24	—	—	—	—	—	—
H11	—	—	100 – 200	0,060 – 0,24	—	—	70 – 180	0,10 – 0,24	—	—
H21	140 – 210	0,20 – 0,60	160 – 250	0,20 – 0,60	—	—	130 – 230	0,20 – 0,60	—	—
H31	50 – 100	0,20 – 0,80	—	—	—	—	30 – 130	0,16 – 0,70	30 – 115	0,16 – 0,60
PM1	100 – 200	0,070 – 0,22	100 – 220	0,070 – 0,22	—	—	—	—	—	—
PM2	100 – 200	0,070 – 0,22	—	—	—	—	—	—	—	—
HF1	100 – 150	0,10 – 0,30	—	—	—	—	100 – 200	0,10 – 0,28	—	—
HF2	170 – 250	0,10 – 0,30	—	—	—	—	170 – 270	0,10 – 0,28	—	—
CC1	—	—	20 – 40	0,040 – 0,20	—	—	20 – 35	0,050 – 0,24	—	—

PCBN, Finishing $a_p < 0,5$ mm

SMG	CBN010		CBN060K		CBN150		CBN160C		CBN170	
	v_c	f	v_c	f	v_c	f	v_c	f	v_c	f
K1	—	—	—	—	—	—	—	—	—	—
K2	—	—	150 – 350	0,050 – 0,22	120 – 280	0,040 – 0,22	120 – 300	0,060 – 0,24	—	—
K4	160 – 280	0,050 – 0,20	—	—	180 – 300	0,050 – 0,19	—	—	—	—
K5	80 – 600	0,050 – 0,20	—	—	—	—	80 – 500	0,050 – 0,21	—	—
S1	170 – 350	0,10 – 0,25	—	—	—	—	—	—	—	—
S2	170 – 350	0,050 – 0,20	—	—	—	—	—	—	—	—
S3	170 – 350	0,10 – 0,25	—	—	—	—	—	—	170 – 350	0,010 – 0,28
H3	80 – 230	0,030 – 0,25	100 – 240	0,030 – 0,28	75 – 180	0,030 – 0,20	100 – 200	0,030 – 0,24	—	—
H5	80 – 215	0,030 – 0,25	90 – 220	0,030 – 0,28	70 – 160	0,030 – 0,20	90 – 180	0,030 – 0,24	—	—
H7	100 – 220	0,060 – 0,18	100 – 230	0,060 – 0,20	100 – 170	0,050 – 0,17	100 – 190	0,070 – 0,21	—	—
H8	90 – 200	0,010 – 0,19	90 – 220	0,010 – 0,20	70 – 150	0,020 – 0,15	70 – 180	0,020 – 0,17	—	—
H11	100 – 220	0,030 – 0,16	100 – 230	0,030 – 0,18	60 – 160	0,030 – 0,16	80 – 180	0,040 – 0,18	—	—
H21	—	—	—	—	—	—	—	—	—	—
H31	—	—	—	—	—	—	—	—	—	—
PM1	—	—	—	—	—	—	110 – 250	0,050 – 0,25	—	—
PM2	—	—	—	—	80 – 200	0,050 – 0,25	90 – 200	0,050 – 0,25	—	—
PM3	80 – 170	0,050 – 0,20	—	—	80 – 170	0,050 – 0,20	80 – 170	0,050 – 0,20	—	—
HF1	50 – 150	0,020 – 0,17	—	—	50 – 120	0,020 – 0,17	50 – 150	0,020 – 0,18	—	—
HF2	60 – 190	0,010 – 0,18	—	—	60 – 190	0,020 – 0,17	100 – 200	0,020 – 0,17	—	—
CC1	—	—	—	—	—	—	—	—	—	—

SMG	CBN200		CBN300		CBN400C		CBN500		CBN600	
	v_c	f	v_c	f	v_c	f	v_c	f	v_c	f
K1	500 – 1300	0,10 – 0,50	500 – 1700	0,10 – 0,60	600 – 1800	0,10 – 0,60	—	—	500 – 1300	0,10 – 0,55
K2	—	—	—	—	—	—	—	—	—	—
K4	—	—	—	—	—	—	—	—	—	—
K5	—	—	—	—	—	—	—	—	—	—
S1	—	—	—	—	—	—	—	—	—	—
S2	—	—	—	—	—	—	—	—	—	—
S3	—	—	—	—	—	—	—	—	—	—
H3	—	—	—	—	—	—	—	—	—	—
H5	—	—	—	—	—	—	—	—	—	—
H7	—	—	—	—	—	—	—	—	—	—
H8	—	—	—	—	—	—	—	—	—	—
H11	—	—	—	—	—	—	—	—	—	—
H21	150 – 230	0,10 – 0,60	170 – 250	0,10 – 0,60	—	—	150 – 230	0,10 – 0,60	—	—
H31	50 – 120	0,15 – 0,44	—	—	—	—	40 – 150	0,12 – 0,44	40 – 130	0,12 – 0,36
PM1	130 – 300	0,050 – 0,24	—	—	—	—	—	—	—	—
PM2	120 – 250	0,050 – 0,20	—	—	—	—	—	—	—	—
PM3	100 – 200	0,050 – 0,15	—	—	—	—	—	—	—	—
HF1	—	—	—	—	—	—	—	—	—	—
HF2	—	—	—	—	—	—	—	—	—	—
CC1	—	—	20 – 40	0,040 – 0,15	—	—	—	—	—	—

PCBN, Plunging

SMG	CBN010		CBN060K		CBN150		CBN160C	
	v _c	f	v _c	f	v _c	f	v _c	f
K1	—	—	—	—	—	—	—	—
K2	—	—	150 — 350	0,050 — 0,22	120 — 280	0,040 — 0,22	120 — 300	0,060 — 0,24
K4	160 — 280	0,050 — 0,20	—	—	180 — 300	0,050 — 0,19	—	—
K5	80 — 600	0,050 — 0,20	—	—	—	—	80 — 500	0,050 — 0,21
S1	170 — 350	0,10 — 0,25	—	—	—	—	—	—
S2	170 — 350	0,050 — 0,20	—	—	—	—	—	—
S3	170 — 350	0,10 — 0,25	—	—	—	—	—	—
H3	250 — 400	0,020 — 0,080	270 — 430	0,020 — 0,090	225 — 375	0,020 — 0,080	250 — 400	0,020 — 0,090
H5	230 — 370	0,020 — 0,080	250 — 400	0,030 — 0,090	200 — 350	0,020 — 0,080	230 — 370	0,020 — 0,090
H7	300 — 450	0,010 — 0,070	300 — 480	0,020 — 0,080	250 — 400	0,010 — 0,070	300 — 450	0,010 — 0,080
H8	100 — 250	0,010 — 0,080	120 — 270	0,020 — 0,10	100 — 220	0,010 — 0,080	100 — 250	0,010 — 0,090
H11	150 — 220	0,020 — 0,090	100 — 230	0,030 — 0,18	60 — 160	0,030 — 0,16	80 — 180	0,040 — 0,18
H21	—	—	—	—	—	—	—	—
H31	—	—	—	—	—	—	—	—
PM1	—	—	—	—	—	—	110 — 250	0,050 — 0,25
PM2	—	—	—	—	150 — 250	0,030 — 0,10	150 — 250	0,030 — 0,12
PM3	110 — 230	0,030 — 0,10	—	—	100 — 200	0,030 — 0,10	100 — 200	0,030 — 0,12
HF1	50 — 150	0,020 — 0,17	—	—	50 — 120	0,020 — 0,17	50 — 150	0,020 — 0,18
HF2	60 — 190	0,010 — 0,18	—	—	60 — 190	0,020 — 0,17	100 — 200	0,020 — 0,17
CC1	—	—	—	—	—	—	—	—

SMG	CBN200		CBN300		CBN400C		CBN500	
	v _c	f	v _c	f	v _c	f	v _c	f
K1	500 — 1500	0,020 — 0,060	800 — 1800	0,020 — 0,060	600 — 1600	0,020 — 0,060	—	—
K2	—	—	—	—	—	—	—	—
K4	—	—	—	—	—	—	—	—
K5	—	—	—	—	—	—	—	—
S1	—	—	—	—	—	—	—	—
S2	—	—	—	—	—	—	—	—
S3	—	—	—	—	—	—	—	—
H3	—	—	—	—	—	—	—	—
H5	—	—	—	—	—	—	—	—
H7	—	—	—	—	—	—	—	—
H8	—	—	—	—	—	—	—	—
H11	—	—	—	—	—	—	—	—
H21	—	—	100 — 180	0,020 — 0,080	—	—	100 — 200	0,020 — 0,080
H31	50 — 100	0,020 — 0,12	—	—	—	—	40 — 120	0,020 — 0,13
PM1	200 — 350	0,030 — 0,15	—	—	—	—	—	—
PM2	150 — 250	0,030 — 0,12	—	—	—	—	—	—
PM3	100 — 180	0,030 — 0,12	—	—	—	—	—	—
HF1	—	—	—	—	—	—	—	—
HF2	—	—	—	—	—	—	—	—
CC1	—	—	20 — 40	0,040 — 0,15	—	—	—	—

PCBN, Grooving

SMG	CBN010		CBN170		CBN200	
	v _c	f	v _c	f	v _c	f
K1	—	—	—	—	500 — 1200	0,090 — 0,18
K2	200 — 400	0,020 — 0,10	—	—	—	—
K4	100 — 300	0,030 — 0,070	—	—	—	—
S1	150 — 300	0,050 — 0,15	—	—	—	—
S2	150 — 300	0,050 — 0,15	—	—	40 — 60	0,020 — 0,10
S3	150 — 300	0,050 — 0,15	150 — 350	0,050 — 0,20	—	—
H3	100 — 280	0,010 — 0,070	—	—	—	—
H5	90 — 250	0,010 — 0,070	—	—	—	—
H7	90 — 250	0,020 — 0,070	—	—	—	—
H8	80 — 300	0,020 — 0,070	—	—	80 — 130	0,020 — 0,070
H11	120 — 220	0,020 — 0,060	—	—	—	—
H21	—	—	—	—	100 — 200	0,010 — 0,080
H31	—	—	—	—	50 — 100	0,030 — 0,10

Troubleshooting

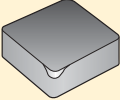
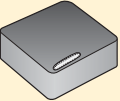
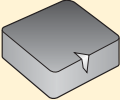
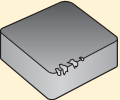
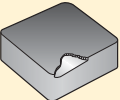
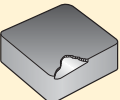
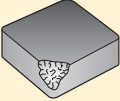
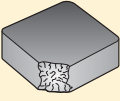
Problem	Cause	Suggested action(s)
Flank wear 	Not correct edge temperature	<ul style="list-style-type: none"> • Increase cutting speed • Increase feed rate • Increase depth of cut • Check cutting tool centre height • Check the ferrite content
Crater wear 	Not correct edge temperature	<ul style="list-style-type: none"> • Decrease cutting speed • Decrease feed rate • Reduce chamfer angle • Use E edge preparation • Use coated insert • Use coolant (only in continuous cut)
Notch wear 	Not correct edge temperature Too high cutting forces	<ul style="list-style-type: none"> • Increase cutting speed • Decrease feed rate • Increase insert approach angle (preferably round inserts) • Vary the depth of cut • Use inserts with chamfered cutting edges
Edge chipping 	Too high cutting forces	<ul style="list-style-type: none"> • Use inserts with chamfered cutting edges • Increase system rigidity • For interrupted cuts, chamfer the tool entry/exit slots and holes • Vary the cutting speed to eliminate vibrations
Edge flaking (continuous cut) 	Too high cutting forces	<ul style="list-style-type: none"> • Increase cutting speed • Reduce feed rate • Use chamfered and honed cutting edges • Check cutting tool centre height • Reduce insert approach angle
Edge flaking (interrupted cut) 	Too high cutting forces	<ul style="list-style-type: none"> • Do not use coolant • Use chamfered and honed cutting edges • Reduce feed rate • Increase cutting speed • Check cutting tool centre height • Reduce insert approach angle
Edge breakage 	Too high cutting forces	<ul style="list-style-type: none"> • Reduce depth of cut • Reduce cutting speed • Increase nose radius • Use chamfered and honed inserts • Check cutting tool centre height
Insert breakage 	Too high cutting forces	<ul style="list-style-type: none"> • Check insert seating • Check insert shim and insert clamp • Check cutting tool centre height

Introduction

Polycrystalline Diamond (PCD) is produced by sintering together carefully selected particles of diamond under conditions of high temperature and high pressure. PCD cutting tools combine the hardness, abrasion resistance and thermal conductivity of diamond with the toughness of tungsten carbide.

Secomax™ PCD inserts are suitable for machining non-ferrous metals and alloys, e.g.:

- Aluminium
- Copper
- Brass
- Bronze

It can also be used for other materials, e.g.:

- Composites (MMC, ...)
- Reinforced plastics
- Graphite
- Cemented/tungsten carbide
- Ceramics
- Titanium alloys

Selection of insert types

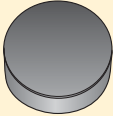
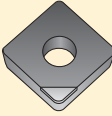
<p>Sintered layer -LF</p>  <p>PCD sintered on carbide. All cutting edges on one side are usable.</p> <p>Grade: PCD30</p> <p>Toolholder style: C</p>	<p>Brazed tip -L1</p>  <p>PCD brazed on to standard carbide inserts.</p> <p>Grades: PCD20, PCD30</p> <p>Toolholder styles: D, P, M and C</p>
---	--

Grades

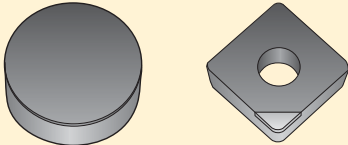
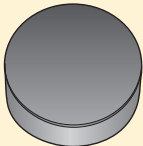
<p>PCD20</p> 	<p>Format: Full-face brazed layer and brazed tips (single sided).</p> <p>Composition: Grade with an average grain size of 10 µm and a Co binder.</p> <p>Coating: No coating.</p>
<p>PCD30</p> 	<p>Format: Full-face brazed layer (single sided).</p> <p>Composition: Grade with an average grain size of 25 µm and a Co binder.</p> <p>Coating: No coating.</p>

Non Ferrous Metals

SMG	Properties	Reference	Recommendations
N1	Aluminum alloys, Si < 9%	AW-7075	First choice for finish and rough machining: PCD20.
N2	Aluminum alloys, 9% < Si < 16%	AC-44200 Si = 12%	First choice for finish and rough machining: PCD20.
N3	Aluminum alloys, Si >16%	AlSi17Cu5	First choice for finish and rough machining: PCD30.
N11	Copper alloys	CW614N	First choice for finish and rough machining: PCD20.

Other Difficult Materials

SMG	Properties	Reference	Recommendations
CC1	Sintered tungsten carbide	G50	Sintered tungsten carbide with a Co content >17%. Second choice for finish machining: PCD30.

Plastics and Composites

SMG	Properties	Reference	Recommendations
TS1	Thermosetting polymers	Urea formaldehyde (UF)	First choice for finish and rough machining: PCD20.
TS2	Thermosetting Carbon fiber composites	T300 T700 T800 HTA-S IMA - Epoxy (M21)...	First choice for finish and rough machining: PCD20.
TS3	Thermosetting Glass fiber composites	Epoxy - HX..(42..)E glass (7781...)...	First choice for finish and rough machining: PCD20.
TP1	Thermoplastic polymers	Polycarbonate (PC)	First choice for finish and rough machining: PCD20.
TP2	Thermoplastic Carbon fiber composites	PPS/PEEK - T300..	First choice for finish and rough machining: PCD20.
TP3	Thermoplastic Glass fiber composites	PPS/PEEK - E glass or A glass...	First choice for finish and rough machining: PCD20.

Graphites

SMG	Properties	Reference	Recommendations
GR1	Graphite	R 8500	First choice for finish- and rough machining: PCD20.



PCD, Roughing a_p 0,5 – 3,0 mm

SMG	PCD20		PCD30	
	v_c	f	v_c	f
N1	600 – 3500	0,050 – 0,30	—	—
N2	450 – 2500	0,050 – 0,20	—	—
N3	300 – 1000	0,050 – 0,10	300 – 1000	0,10 – 0,40
N11	600 – 1200	0,10 – 0,50	600 – 1200	0,10 – 0,50
TS1	100 – 1500	0,10 – 0,40	—	—
TS2	400 – 800	0,10 – 0,20	—	—
TS3	100 – 800	0,050 – 0,20	—	—
TP1	100 – 1500	0,10 – 0,40	—	—
TP2	400 – 800	0,10 – 0,20	—	—
TP3	100 – 800	0,050 – 0,20	—	—
GR1	100 – 1500	0,10 – 0,20	—	—

PCD, Finishing $a_p < 0,5$ mm

SMG	PCD20		PCD30	
	v_c	f	v_c	f
N1	600 – 3500	0,050 – 0,30	—	—
N2	450 – 2500	0,050 – 0,20	—	—
N3	300 – 1000	0,050 – 0,10	300 – 1000	0,10 – 0,40
N11	600 – 1200	0,10 – 0,50	600 – 1200	0,10 – 0,50
CC1	—	—	10 – 20	0,040 – 0,15
TS1	100 – 1500	0,10 – 0,40	—	—
TS2	400 – 800	0,10 – 0,20	—	—
TS3	100 – 800	0,050 – 0,20	—	—
TP1	100 – 1500	0,10 – 0,40	—	—
TP2	400 – 800	0,10 – 0,20	—	—
TP3	100 – 800	0,050 – 0,20	—	—
GR1	100 – 1500	0,10 – 0,20	—	—

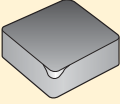
Troubleshooting

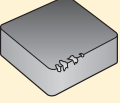
Problem	Cause	Suggested action(s)
Flank wear 	Wrong grade Presence of Fe/Ni/Co	<ul style="list-style-type: none"> • Change to coarser PCD grade • Check material composition • Reduce cutting speed • Use coolant
Built-up edge 	Not correct edge temperature Wrong grade	<ul style="list-style-type: none"> • Decrease or increase cutting speed • Choose a sharper insert • Change to a finer grade
Edge chipping 	Poor rigidity Wrong grade Incorrect cutting data High run-out	<ul style="list-style-type: none"> • Minimize vibrations • Change to a tougher grade • Change cutting data • Check set-up
Poor surface finish	Wrong grade Too high cutting data Incorrect wiper position	<ul style="list-style-type: none"> • Change to a finer PCD grade • Reduce cutting speed and feed rate • Check wiper position
Flaking of work-piece	To high depth of cut	<ul style="list-style-type: none"> • Decrease depth of cut • Add entry chamfer on component

Introduction

Secomax ceramics include a range of products developed to meet the manufacturing industries ever increasing demands on productivity and product performance.

The inserts are die-pressed and sintered by a HIP process using very fine and pure raw materials with fine microstructure to reach excellent material properties. All surfaces are then ground ensuring a product with superior dimensions and tolerances.

This comes together in a product with outstanding features:

- high thermal shock resistance
- optimised fracture toughness
- excellent wear resistance
- high product quality

Application areas

Heat resistant superalloys (HRSA) include a broad range of nickel, iron and cobalt based alloys developed specifically for applications demanding exceptional mechanical and chemical properties at elevated temperatures.

Seco ceramic inserts are intended for rough machining of nickel based heat resistant superalloys. The most common nickel based superalloy is Inconel 718, which is a precipitation hardenable nickel chromium alloy containing significant amounts of iron, niobium and molybdenum along with lesser amounts of aluminium and titanium.

Other common nickel based superalloy names are:

- Hastalloy
- Haynes (Waspaloy)
- MAR
- Nimonic
- Rene
- Udimet

Selection of insert types

Ceramic inserts are only available in solid format.

Solid insert

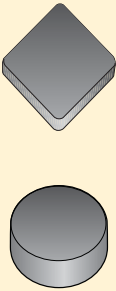

According to the geometry, two sides can be used.

Grade:
CS100

Solid insert

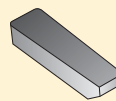

According to the geometry, one edge can be used.

Grade:
CW100

Geometry recommendations

Strong cutting edge geometries are always preferred.

- Negative cutting geometry
- Chamfered cutting edge
- Large nose radius

Edge preparation

- S** = Chamfered and honed
E = Honed

Chamfer size and angle

CS100 = 0,10 mm x 20°

CW100 = Honed

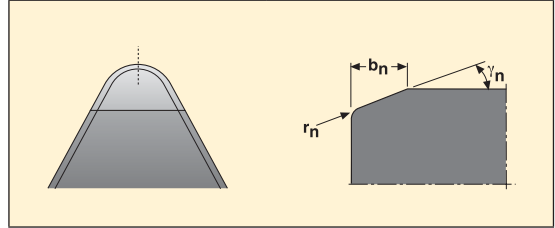

b_n = Chamfer width
 γ_n = Chamfer angle
 r_n = Hone radius

ISO classification

	P					M					K				N				S			H						
	P01	P10	P20	P30	P40	P50	M01	M10	M20	M30	M40	K01	K10	K20	K30	K40	N01	N10	N20	N30	S01	S10	S20	S30	H01	H10	H20	H30
CS100																												
CW100																												

Grades

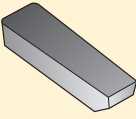
<p>CS100</p> 	<p>Format: Solid.</p> <p>Composition: Sialon (Si, Al, O, N) ceramic grade.</p> <p>Coating: No coating.</p>
<p>CW100</p> 	<p>Format: Solid.</p> <p>Composition: Aluminium oxide (Al₂O₃) + SiC-whisker reinforced ceramic grade.</p> <p>Coating: No coating.</p>

Superalloys

SMG	Properties	Reference	Recommendations
S1	Iron based superalloys	Discalloy	First choice for rough machining: CS100. First choice for grooving: CW100. Use coolant.
S2	Cobalt based superalloys	Stellite 21	First choice for rough machining: CS100. First choice for grooving: CW100. Use coolant.
S3	Nickel based superalloys	Inconel 718	First choice for rough machining: CS100. First choice for grooving: CW100. Use coolant.



Ceramics, Roughing a_p 0,5 – 3,0 mm

SMG	CS100	
	v_c	f
S1	150 – 250	0,10 – 0,40
S2	150 – 300	0,10 – 0,40
S3	150 – 300	0,10 – 0,40

Ceramic, Grooving

SMG	CW100	
	v_c	f
S1	150 – 300	0,050 – 0,25
S2	150 – 300	0,050 – 0,25
S3	150 – 300	0,050 – 0,25

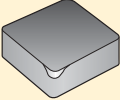
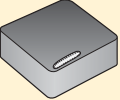
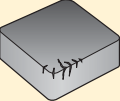
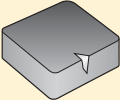
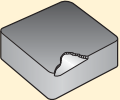
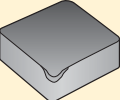
Troubleshooting

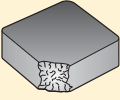
Problem	Cause	Suggested action(s)
Flank wear 	Excessive feed rate and cutting speed	<ul style="list-style-type: none"> • Reduce cutting speed • Use larger corner radius • Use high wear-resistant grade
Crater wear 	Excessive feed rate and cutting speed	<ul style="list-style-type: none"> • Reduce cutting speed • Use smaller lead angle • Check edge geometry
Thermal cracking 	Severe cycle of heating & cooling during cutting Excessive feed rate and cutting speed	<ul style="list-style-type: none"> • Change to dry machining • Reduce cutting speed • Reduce feed rate
Notch wear 	Excessive feed rate and cutting depth	<ul style="list-style-type: none"> • Reduce cutting depth • Reduce feed rate • Increase coolant supply
Edge flaking 	Excessive feed rate Separation of BUE Weak cutting edge	<ul style="list-style-type: none"> • Check edge geometry • Increase stability of the system • Use larger lead angle
Plastic deformation 	Excessive feed rate and cutting speed	<ul style="list-style-type: none"> • Reduce cutting speed • Reduce feed rate • Reduce cutting depth
Built-up edge 	High affinity with workpiece Low cutting speed	<ul style="list-style-type: none"> • Increase cutting speed • Increase feed rate • Use larger rake angle
Breakage 	Excessive feed rate and cutting depth	<ul style="list-style-type: none"> • Reduce feed rate • Reduce cutting depth • Increase stability of the system

Inserts CC..

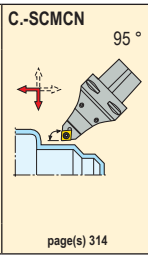
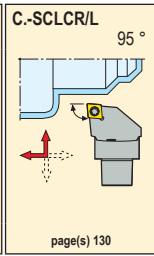
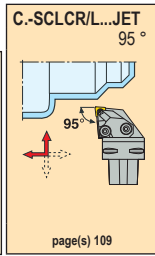
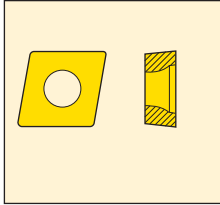

Inserts CN..

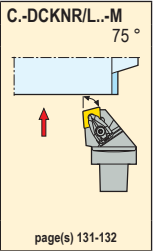
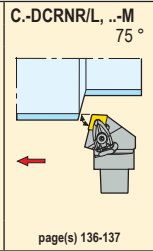
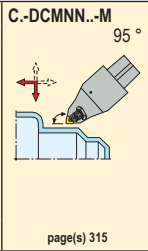
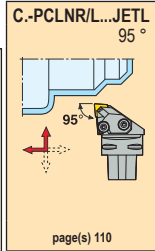
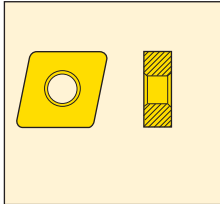

Inserts CN.N

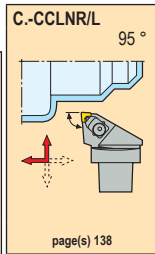

Inserts DC..

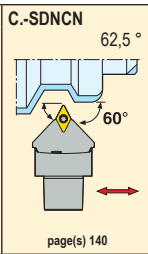
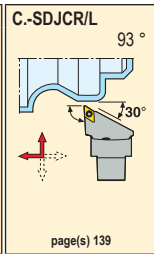
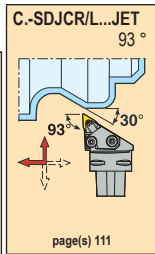
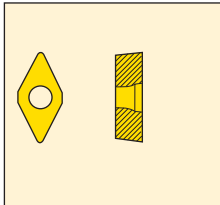

Inserts DN..

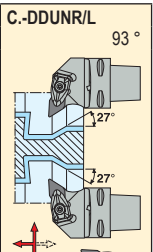
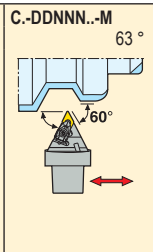
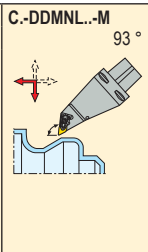
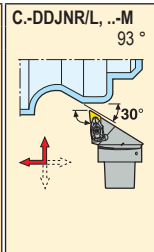
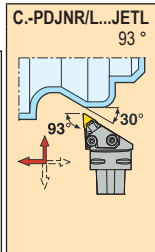
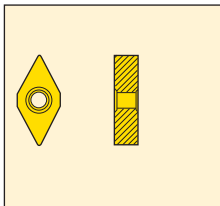

Inserts RC..

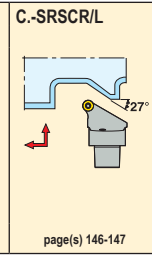
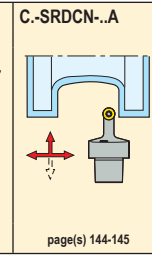
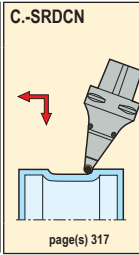
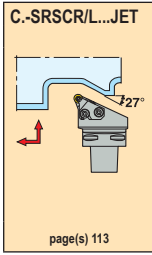
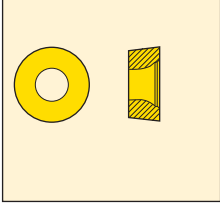

Inserts RN..

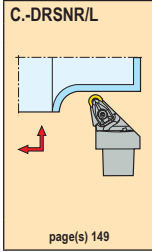
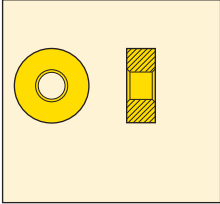

Inserts RN.N

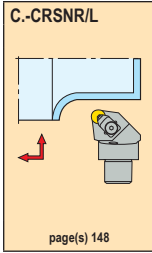
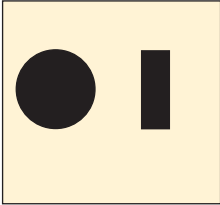

Inserts SC..

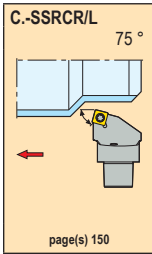
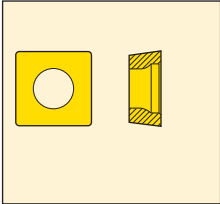

Inserts SN..

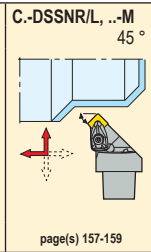
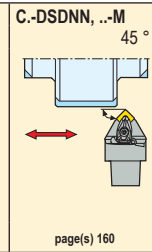
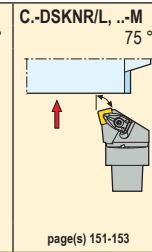
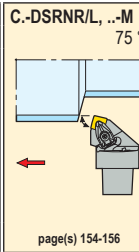
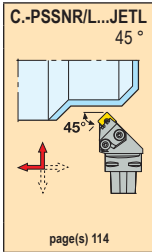
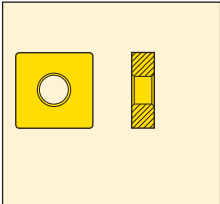

Inserts SN.N

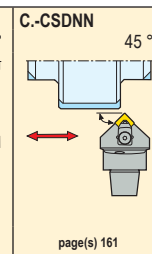
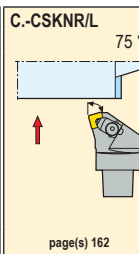
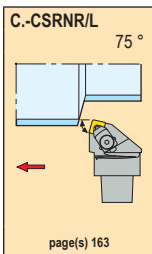

Inserts TC..

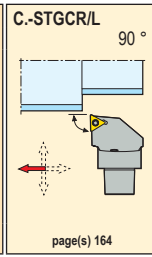
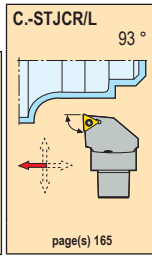
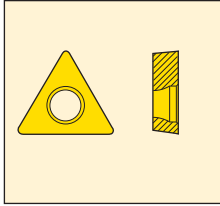

Inserts TN..

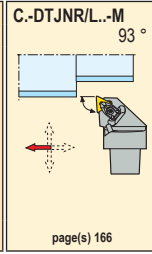
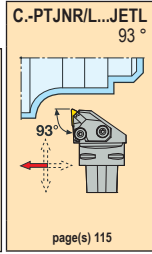
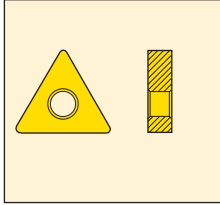

Inserts TN.N

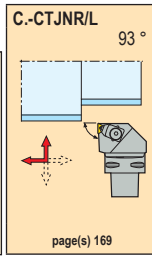

Inserts VB../VC..

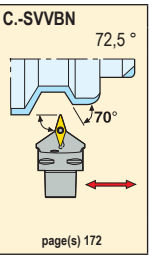
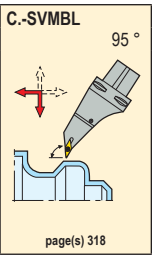
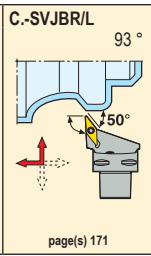
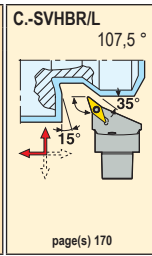
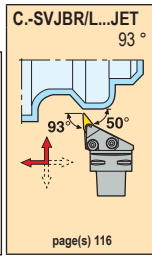
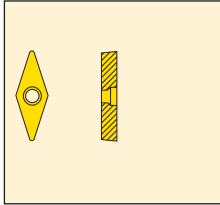

Inserts VN..

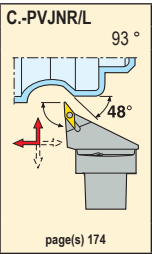
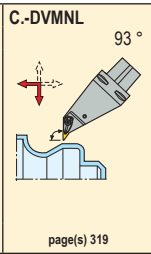
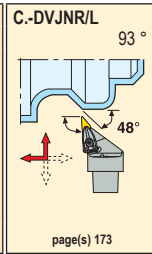
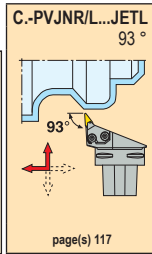
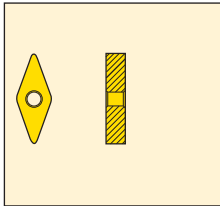

Inserts WC..

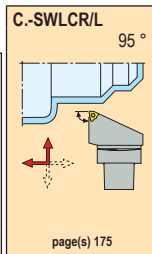
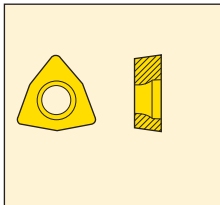

Inserts WN..

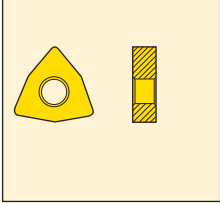

C.-PWLNR/L...JETL 95°

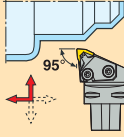

page(s) 118

C.-DWLNR/L 95°

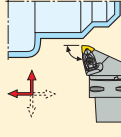

page(s) 176

C.-PWLNN 95°

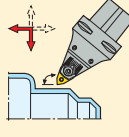

page(s) 320

C.-PWLNR/L 95°

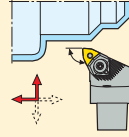

page(s) 177

Inserts CC..

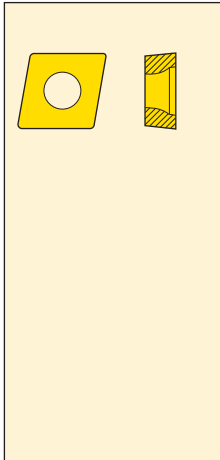

<p>SCLCR/L...JET 95°</p> <p>page(s) 119</p>	<p>SCLCR/L 95°</p> <p>page(s) 181</p>	<p>SCACR/L 90°</p> <p>page(s) 178</p>	<p>SCGCR/L 90°</p> <p>page(s) 182</p>	<p>SCFCR/L 90°</p> <p>page(s) 180</p>	<p>SCBCR/L 75°</p> <p>page(s) 179</p>
<p>SCDCR/L 45°</p> <p>page(s) 180</p>					

Inserts CN..

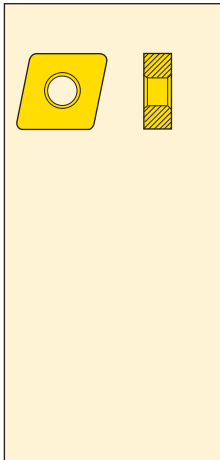

<p>PCLNR/L...JETL 95°</p> <p>page(s) 120</p>	<p>DCLNR/L...M 95°</p> <p>page(s) 185-186</p>	<p>PCLNR/L 95°</p> <p>page(s) 189</p>	<p>MCLNR/L 95°</p> <p>page(s) 188</p>	<p>DCBNR/L...M 75°</p> <p>page(s) 183</p>	<p>PCBNR/L 75°</p> <p>page(s) ;190</p>
<p>MCBNR/L 75°</p> <p>page(s) 187</p>	<p>DCKNR/L...M 75°</p> <p>page(s) 184</p>				

Inserts CN.N

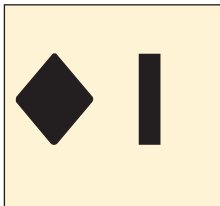

<p>CCLNR/L 95°</p> <p>page(s) 191</p>	<p>CCBNR/L 75°</p> <p>page(s) 191</p>
--	--

Inserts DC..

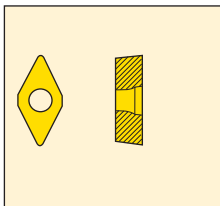

<p>SDJCR/L...JET 93°</p> <p>page(s) 122</p>	<p>SDHCR/L 107,5°</p> <p>page(s) 192</p>	<p>SDJCR/L 93°</p> <p>page(s) 193</p>	<p>SDACR/L 90°</p> <p>page(s) 194</p>	<p>SDNCN 62,5°</p> <p>page(s) 195</p>
--	---	--	--	--

Inserts DN..

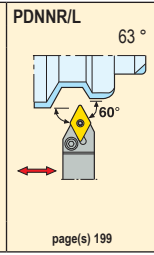
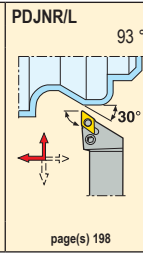
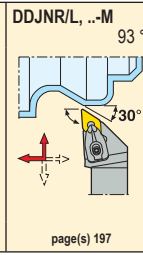
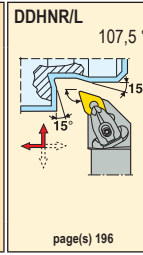
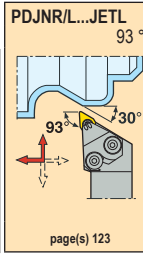
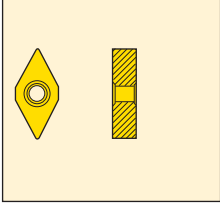

Inserts DN.A

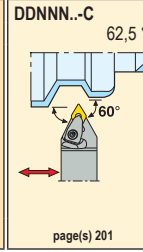
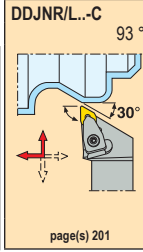
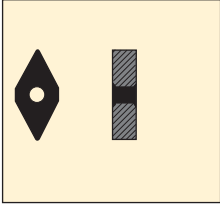

Inserts DN.N

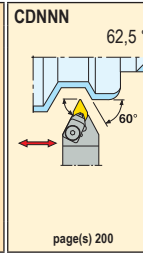
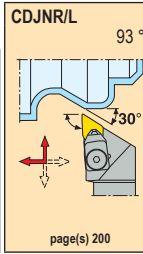
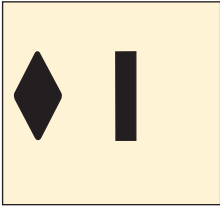

Inserts LN..19/30

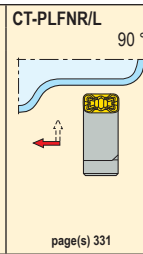
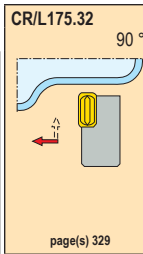
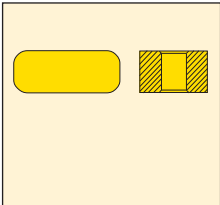

Inserts LN..40/50

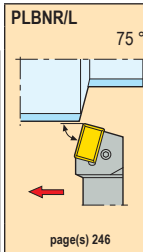
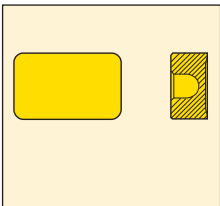

Inserts RC..

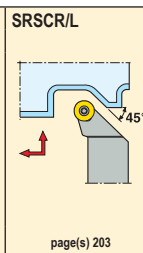
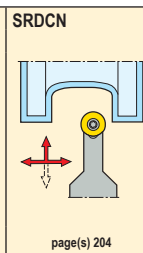
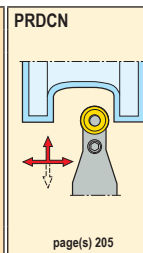
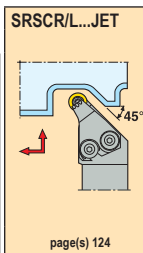
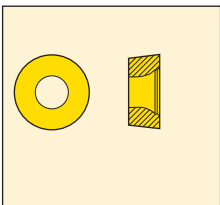

Inserts RCG.

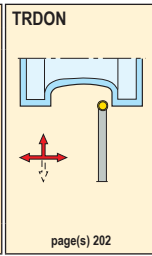
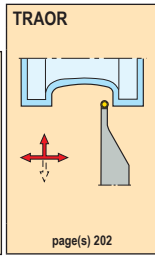
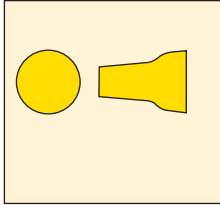

Inserts RN..

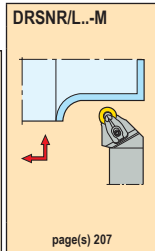
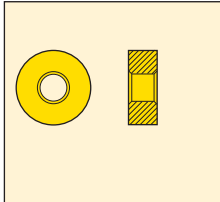

Inserts RN.N

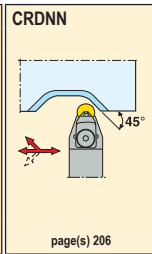
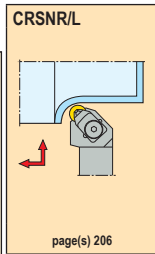
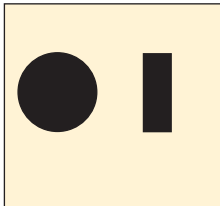

Inserts SC..

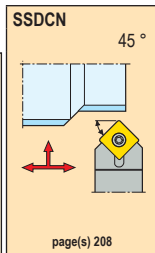
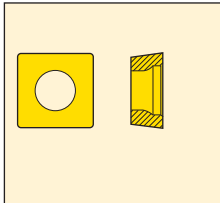

Inserts SN..

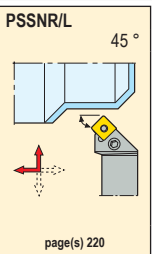
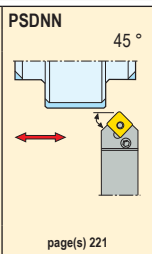
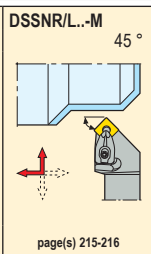
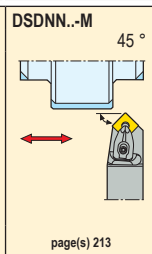
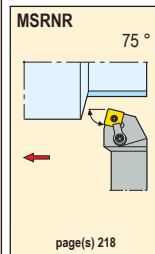
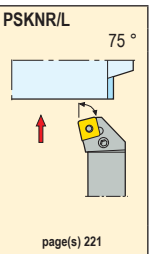
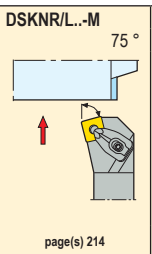
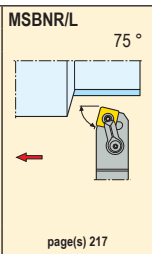
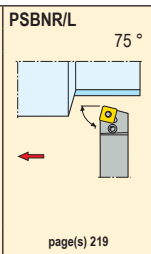
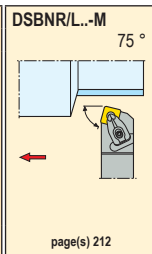
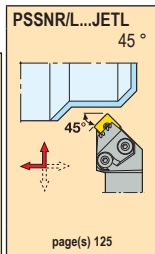
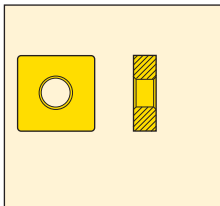

Inserts SN.A

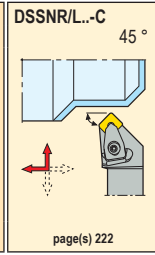
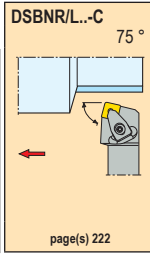
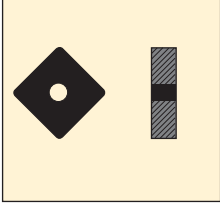

Inserts SN.N

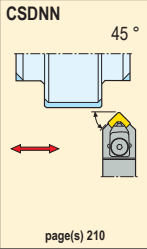
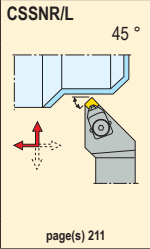
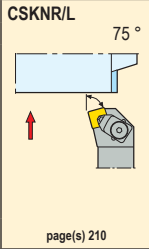
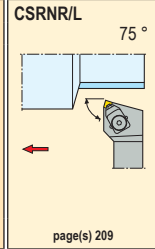
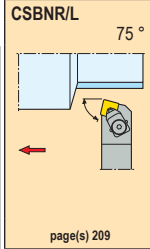
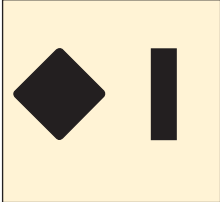

Inserts TC..

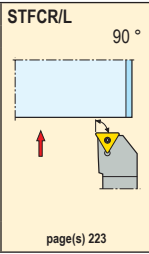
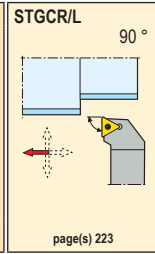
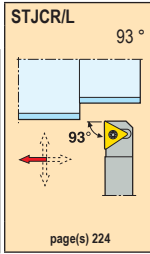
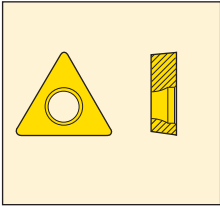

Inserts TN..

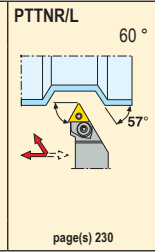
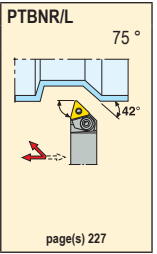
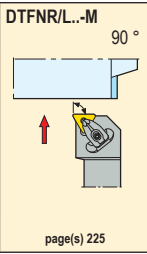
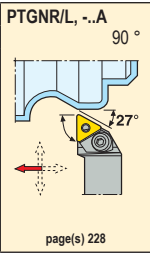
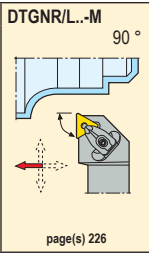
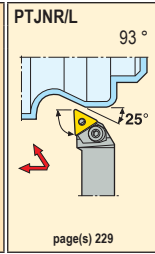
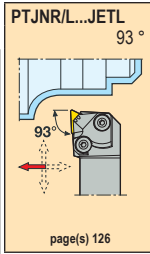
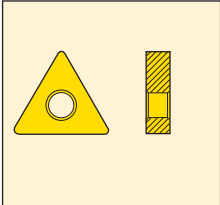

Inserts TN.N

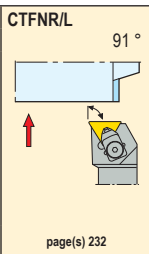
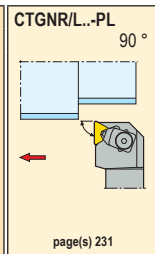
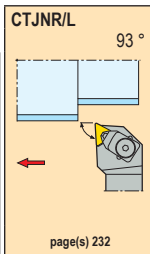

Inserts VB/VC..

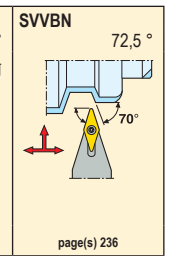
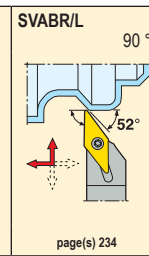
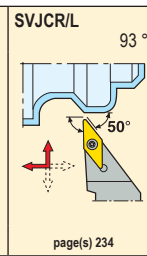
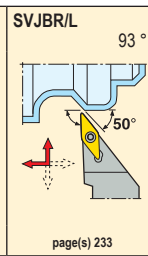
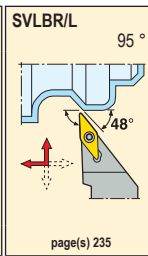
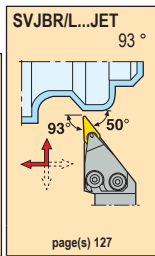
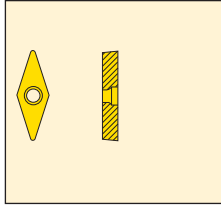

Inserts VN..

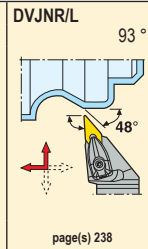
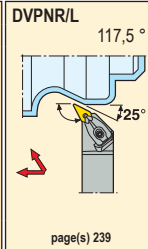
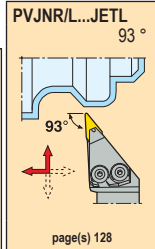
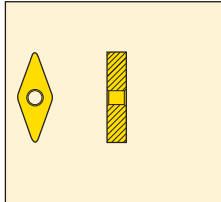

Inserts VN.A

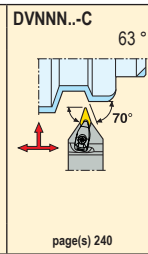
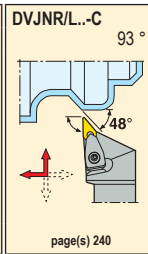
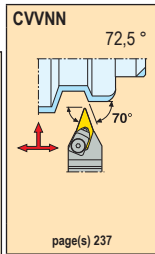
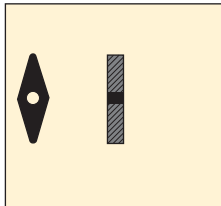

Inserts WC..

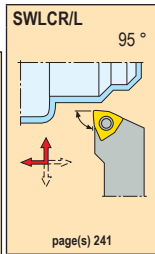
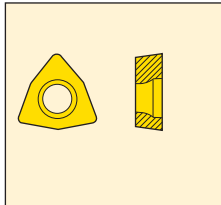

Inserts WN..

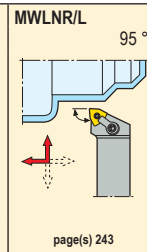
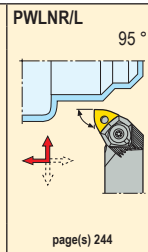
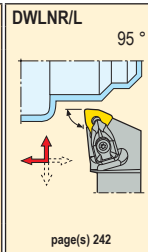
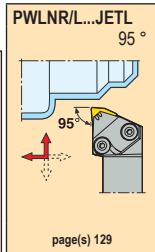
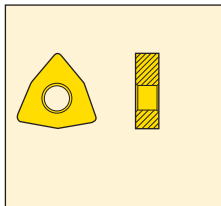

Inserts WN.A

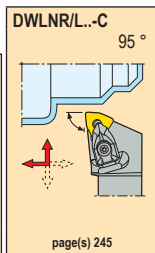
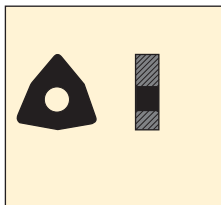

Inserts CC..

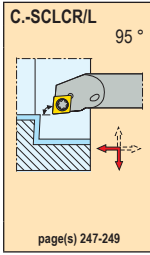
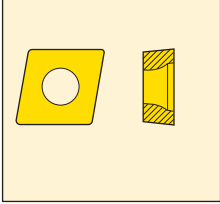

Inserts CN..

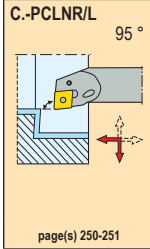
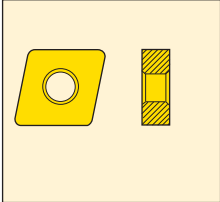

Inserts DC..

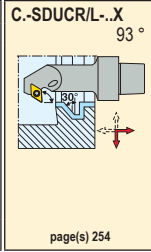
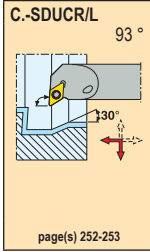
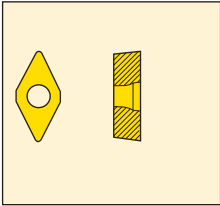

Inserts DN..

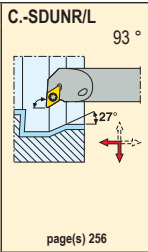
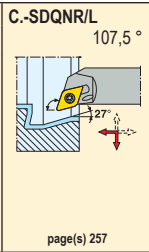
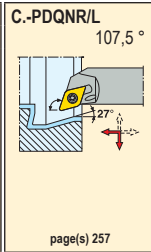
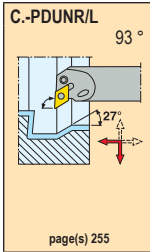
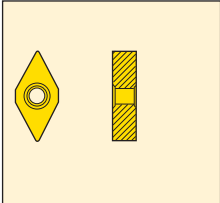

Inserts SC..

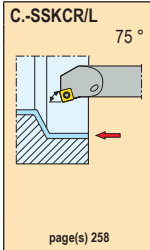
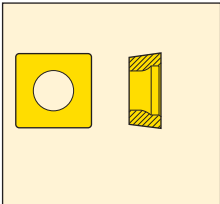

Inserts TC..

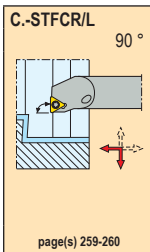
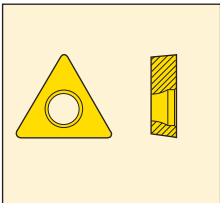

Inserts TN..

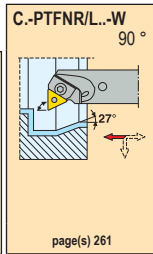
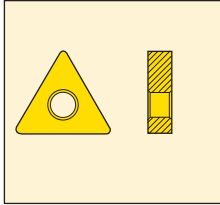

Inserts TN.N

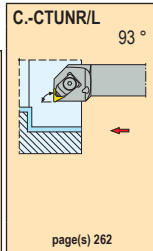

Inserts VB../VC..

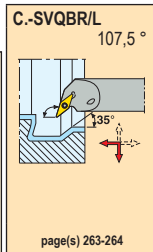
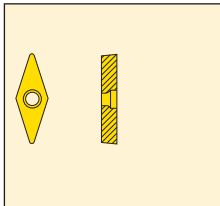

Inserts VN..

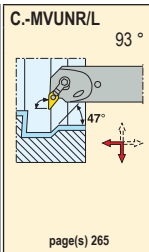
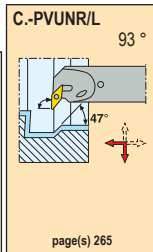
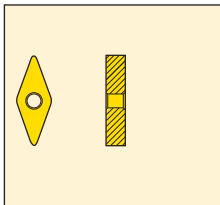

Inserts WC..

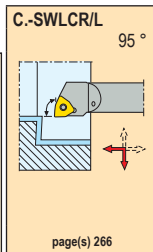
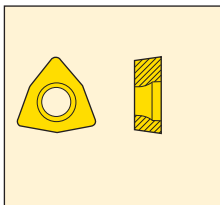

Inserts WN..

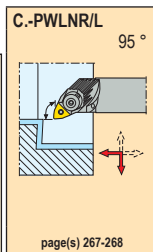
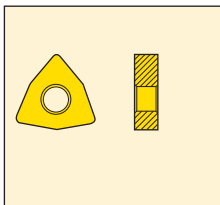

Inserts CC..

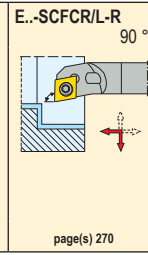
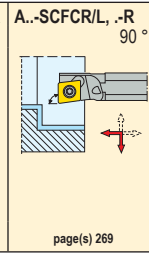
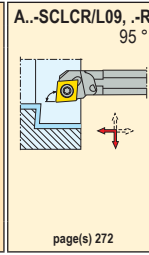
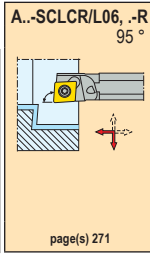
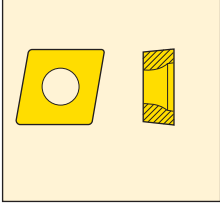

Inserts CD..

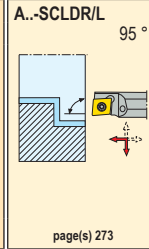
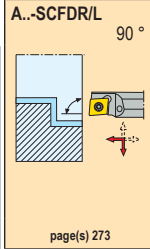
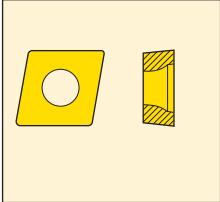

Inserts CN..

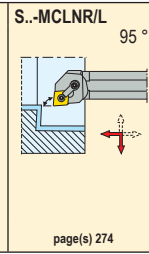
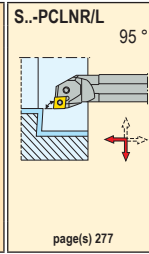
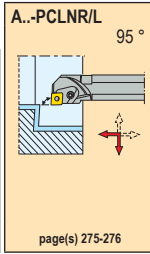
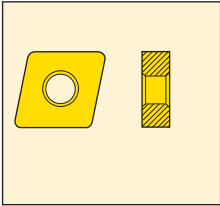

Inserts CN.N

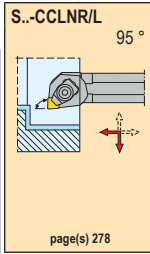
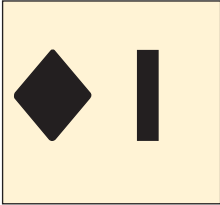

Inserts DC..

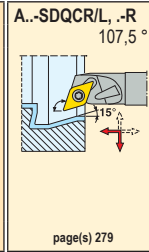
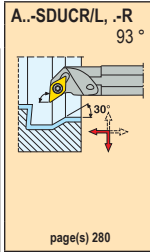
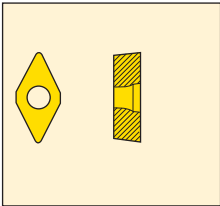

Inserts DN..

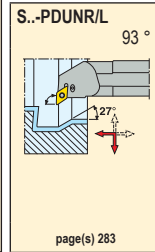
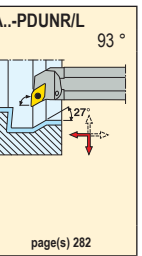
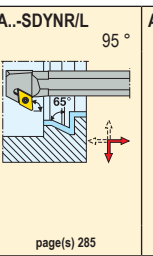
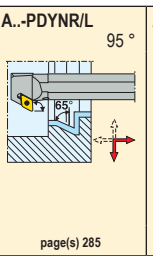
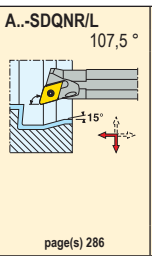
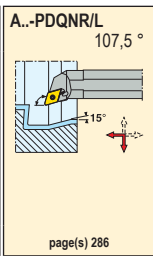
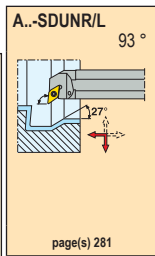
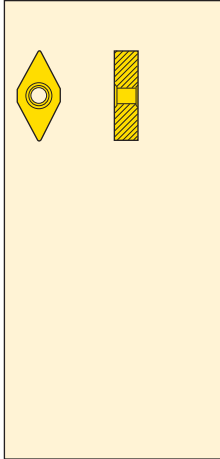

Inserts DNMA

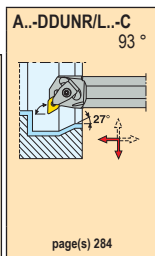
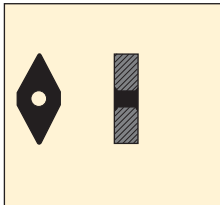

Inserts RN.N

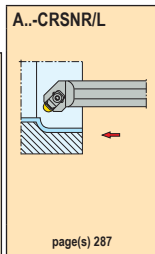
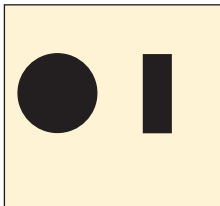

Inserts SN..

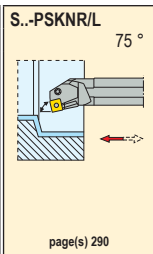
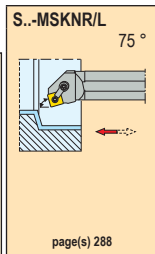
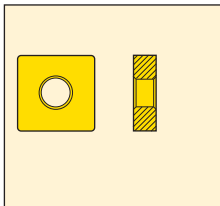

Inserts SN.N

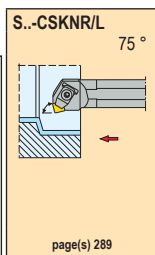

Inserts TC..

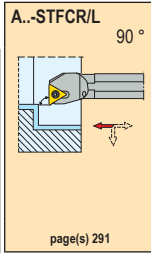
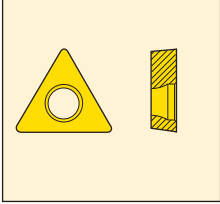

Inserts TD..

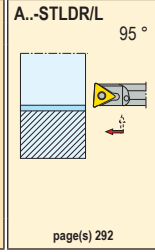
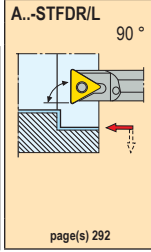
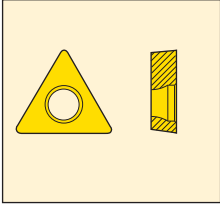

Inserts TN..

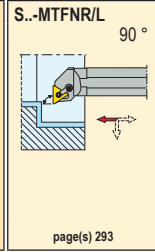
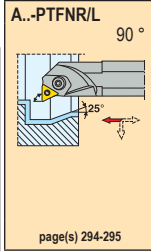
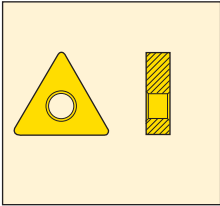

Inserts TN.N

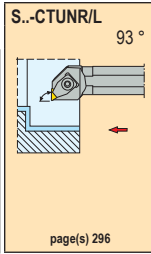

Inserts VB..

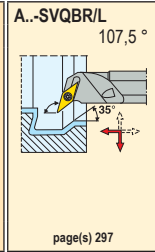
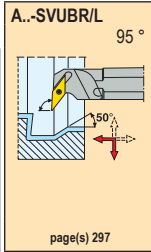
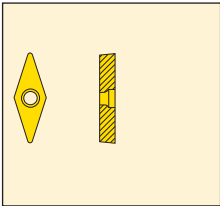

Inserts VN..

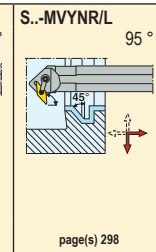
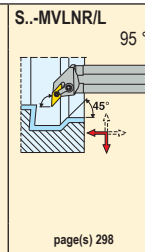
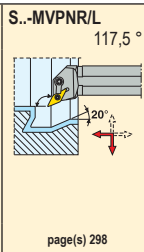
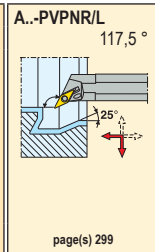
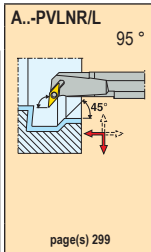
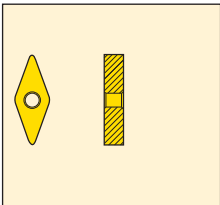

Inserts WC..

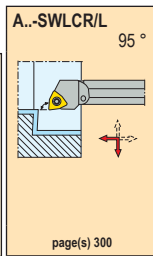
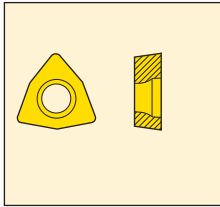

Inserts WN..

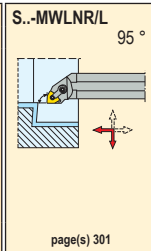
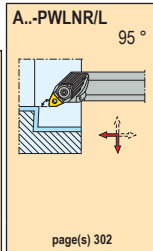
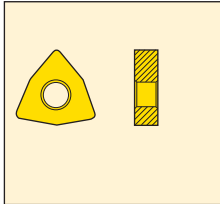

Inserts WN.A

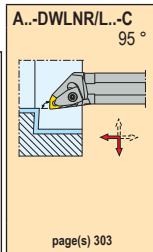
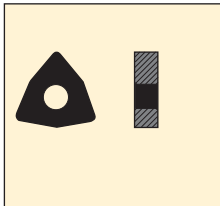

Inserts CC..

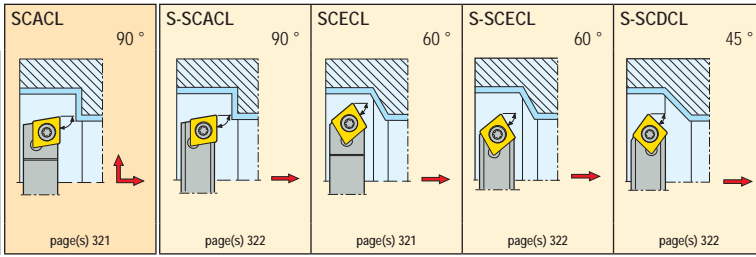
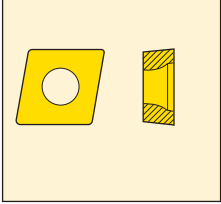

Inserts CC..

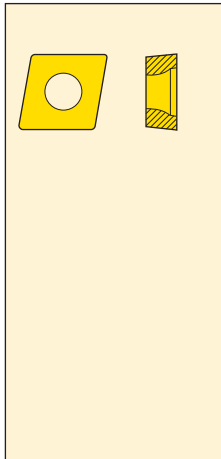

SCFCR/L 90°

page(s) 323

SCLCR/L 95°

page(s) 323

SCGCR/L 90°

page(s) 324

SCRCR/L 75°

page(s) 325

SCTCR/L 60°

page(s) 325

SCWCR/L 60°

page(s) 323

SCSCR/L 45°

page(s) 324

Inserts SC..

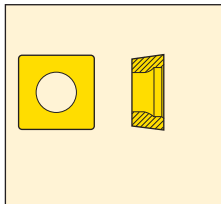

SSKCR/L 75°

page(s) 326

Inserts TC..

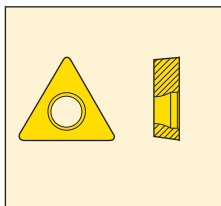

STFCR/L 90°

page(s) 327

STGCR/L 90°

page(s) 328

STRCR/L 75°

page(s) 328

STTCR/L 60°

page(s) 328

STWCR/L 60°

page(s) 327

STSCR/L 45°

page(s) 327



Toolholders for inserts CCGT, CCGW, CCMT and CCMW



- For insert programme, see page(s) 343-347, 400-401, 431-432
- γ_0° = Rake angle, λ_s° = Inclination angle
- For holder code key, see page(s) 10-11

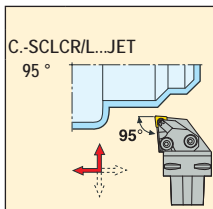
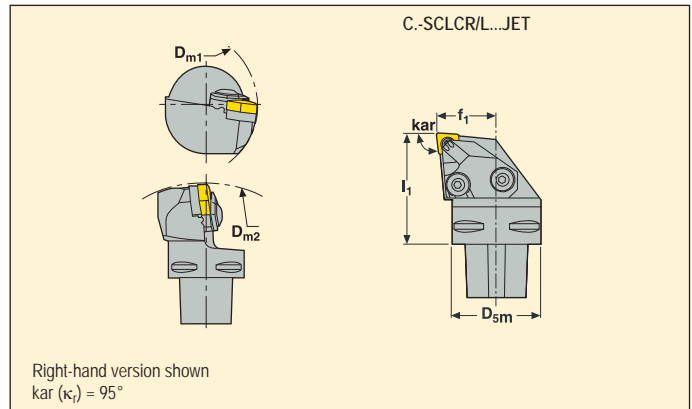

Capto size	Part No.	Dimensions in mm					γ_0°	λ_s°	KG	
		D _{sm}	f ₁	I ₁	D _{m1}	D _{m2}				
C4	C4-SCLCR -27050-09JET	40	27,0	50	75	165	0	0	0,5	CC..09T3..
	C4-SCLCL -27050-09JET	40	27,0	50	75	165	0	0	0,5	CC..09T3..
	C4-SCLCR -27050-12JET	40	27,0	50	75	165	0	0	0,5	CC..1204..
	C4-SCLCL -27050-12JET	40	27,0	50	75	165	0	0	0,5	CC..1204..
C5	C5-SCLCR -35060-09JET	50	35,0	60	95	165	0	0	0,8	CC..09T3..
	C5-SCLCL -35060-09JET	50	35,0	60	95	165	0	0	0,8	CC..09T3..
	C5-SCLCR -35060-12JET	50	35,0	60	95	165	0	0	0,7	CC..1204..
	C5-SCLCL -35060-12JET	50	35,0	60	95	165	0	0	0,7	CC..1204..
C6	C6-SCLCR -45065-09JET	63	45,0	65	121	165	0	0	1,3	CC..09T3..
	C6-SCLCL -45065-09JET	63	45,0	65	121	165	0	0	1,3	CC..09T3..
	C6-SCLCR -45065-12JET	63	45,0	65	121	165	0	0	1,3	CC..1204..
	C6-SCLCL -45065-12JET	63	45,0	65	121	165	0	0	1,3	CC..1204..

Spare Parts, Parts included in delivery

Accessories*

For size	Inducer kit	Inducer screw	Insert/inducer key	Insert screw	Insert shim	O-ring	Shim screw	Shim key
...R-09	JET-CIKC12RC-KIT	117.26-655	3SMS795/T15P	C04008-T15P	-	ORING-8X1.5	-	-
...L-09	JET-CIKC12LC-KIT	117.26-655	3SMS795/T15P	C04008-T15P	-	ORING-8X1.5	-	-
...R-12	JET-CIKC12RC-KIT	117.26-655	3SMS795/T15P	C05012-T15P	123.19-621	ORING-8X1.5	CA5008	5SMS795
...L-12	JET-CIKC12LC-KIT	117.26-655	3SMS795/T15P	C05012-T15P	123.19-621	ORING-8X1.5	CA5008	5SMS795

Please check availability in current price and stock-list

*To be ordered separately

Toolholders for inserts CNGA, CNGG, CNMA, CNMG and CNMM



- For insert programme, see page(s) 348-355, 402, 431
- γ_0° = Rake angle, λ_s° = Inclination angle
- For holder code key, see page(s) 10-11

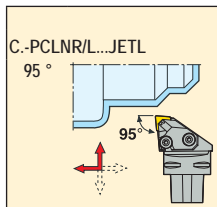
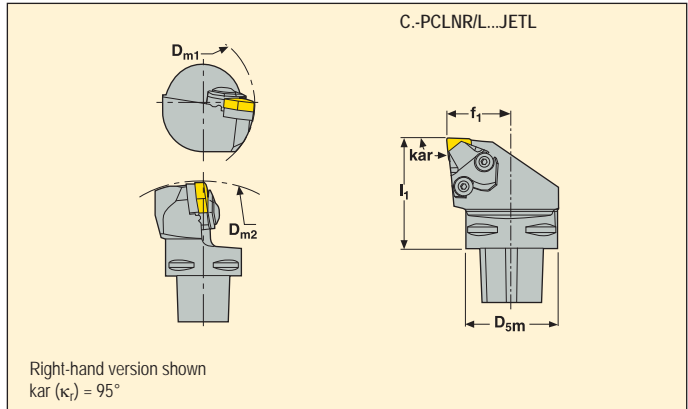

Capto size	Part No.	Dimensions in mm						γ_0°	λ_s°	KG	Key
		D _{5m}	f ₁	l ₁	D _{m1}	D _{m2}					
C4	C4-PCLNR -27050-12JETL	40	27,0	50	75	165	-6	-6	0,5	CN..1204..	
	C4-PCLNL -27050-12JETL	40	27,0	50	75	165	-6	-6	0,5	CN..1204..	
C5	C5-PCLNR -35060-12JETL	50	35,0	60	95	165	-6	-6	0,9	CN..1204..	
	C5-PCLNL -35060-12JETL	50	35,0	60	95	165	-6	-6	0,9	CN..1204..	
C6	C6-PCLNR -45065-12JETL	63	45,0	65	121	165	-6	-6	1,5	CN..1204..	
	C6-PCLNL -45065-12JETL	63	45,0	65	121	165	-6	-6	1,5	CN..1204..	
	C6-PCLNR -45065-16JETL	63	45,0	65	150	200	-6	-6	1,4	CN..1606..	
	C6-PCLNL -45065-16JETL	63	45,0	65	150	200	-6	-6	1,4	CN..1606..	

Spare Parts, Parts included in delivery

Accessories*

For size	Inducer	Inducer screw	Insert lever	Insert shim	Lever/inducer key	Lever screw	O-ring	Punch	Shim pin	Inducer
...R-12	CILC12RA-F	117.26-655	PP4713	PCN120308	3SMS795	LS0818	ORING-8X1.5	MP0912	RP6757	CILC12RA-R
...L-12	CILC12LA-F	117.26-655	PP4713	PCN120308	3SMS795	LS0818	ORING-8X1.5	MP0912	RP6757	CILC12LA-R
...R-16	CILC16RA-F	117.26-655	PP6017	PCN160412	3SMS795	LS0820	ORING-8X1.5	MP1519	RP8286	CILC16RA-R
...L-16	CILC16LA-F	117.26-655	PP6017	PCN160412	3SMS795	LS0820	ORING-8X1.5	MP1519	RP8286	CILC16LA-R

Please check availability in current price and stock-list

*To be ordered separately

Toolholders for inserts RCMT



- For insert programme, see page(s) 369
- γ_0° = Rake angle, λ_s° = Inclination angle
- For holder code key, see page(s) 10-11

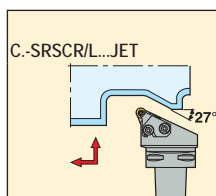
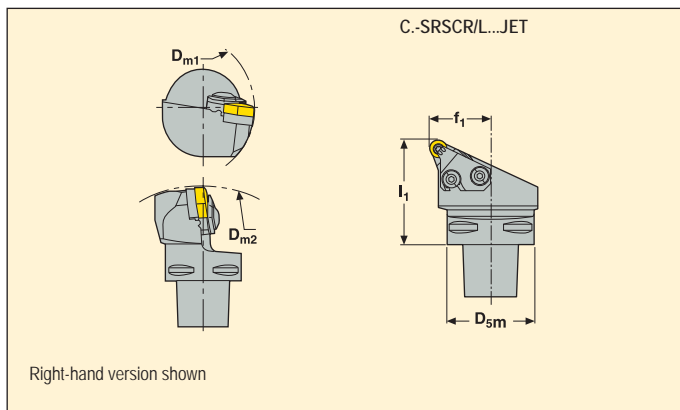

Capto size	Part No.	Dimensions in mm						γ_0°	λ_s°	KG	
		D_{sm}	f_1	l_1	D_{m1}	D_{m2}					
C4	C4-SRSCR -27050-10JET	40	27,0	50	75	165	0	0	0,4	RCMT10T3..	
	C4-SRSCCL -27050-10JET	40	27,0	50	75	165	0	0	0,4	RCMT10T3..	
	C4-SRSCR -27050-12JET	40	27,0	50	75	165	0	0	0,4	RCMT1204..	
	C4-SRSCCL -27050-12JET	40	27,0	50	75	165	0	0	0,4	RCMT1204..	
C5	C5-SRSCR -35060-10JET	50	35,0	60	95	165	0	0	0,8	RCMT10T3..	
	C5-SRSCCL -35060-10JET	50	35,0	60	95	165	0	0	0,8	RCMT10T3..	
	C5-SRSCR -35060-12JET	50	35,0	60	95	165	0	0	0,8	RCMT1204..	
	C5-SRSCCL -35060-12JET	50	35,0	60	95	165	0	0	0,8	RCMT1204..	
C6	C6-SRSCR -45065-10JET	63	45,0	65	121	165	0	0	1,2	RCMT10T3..	
	C6-SRSCCL -45065-10JET	63	45,0	65	121	165	0	0	1,2	RCMT10T3..	
	C6-SRSCR -45065-12JET	63	45,0	65	121	165	0	0	1,2	RCMT1204..	
	C6-SRSCCL -45065-12JET	63	45,0	65	121	165	0	0	1,2	RCMT1204..	

Spare Parts, Parts included in delivery

Accessories*

For size	Inducer kit	Inducer screw	Insert/inducer key	Insert screw	Insert shim	O-ring	Shim screw	Shim key
...R-10	JET-CIKR00RB-KIT	117.26-655	3SMS795/T15P	C03510-T15P	111.19-620	ORING-6.07X1.78	CA3510	9/64SMS875
...L-10	JET-CIKR00LB-KIT	117.26-655	3SMS795/T15P	C03510-T15P	111.19-620	ORING-6.07X1.78	CA3510	9/64SMS875
...R-12	JET-CIKR00RB-KIT	117.26-655	3SMS795/T15P	C03510-T15P	111.19-621	ORING-6.07X1.78	CA3510	9/64SMS875
...L-12	JET-CIKR00LB-KIT	117.26-655	3SMS795/T15P	C03510-T15P	111.19-621	ORING-6.07X1.78	CA3510	9/64SMS875

Please check availability in current price and stock-list

*To be ordered separately

Toolholders for inserts SNGA, SNMA, SNMG and SNMM



- For insert programme, see page(s) 374-378, 413, 416
- γ_0° = Rake angle, λ_s° = Inclination angle
- For holder code key, see page(s) 10-11

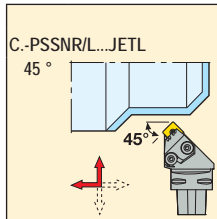
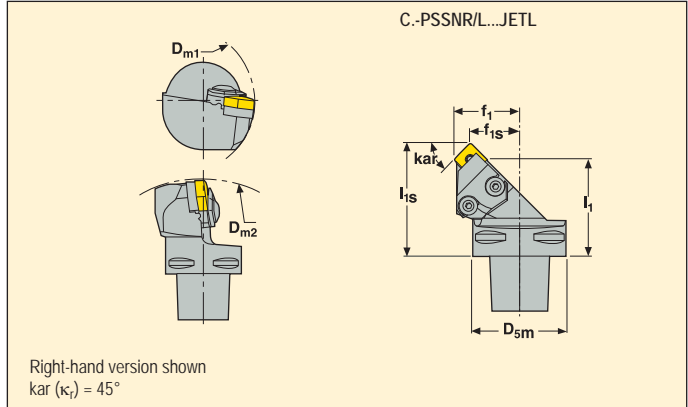

Capto size	Part No.	Dimensions in mm								γ_0°	λ_s°	KG	Key
		D _{5m}	f ₁	f _{1s}	l ₁	l _{1s}	D _{m1}	D _{m2}					
C4	C4-PSSNR -27048-12JETL	40	27,0	19,0	48	56	95	165	165	-8	0	0,5	SN..1204..
	C4-PSSNL -27048-12JETL	40	27,0	19,0	48	56	95	165	165	-8	0	0,5	SN..1204..
C5	C5-PSSNR -35052-12JETL	50	35,0	27,0	52	60	95	165	165	-8	0	0,7	SN..1204..
	C5-PSSNL -35052-12JETL	50	35,0	27,0	52	60	95	165	165	-8	0	0,7	SN..1204..
C6	C6-PSSNR -45056-12JETL	63	45,0	37,0	56	64	121	165	165	-8	0	1,1	SN..1204..
	C6-PSSNL -45056-12JETL	63	45,0	37,0	56	64	121	165	165	-8	0	1,1	SN..1204..
	C6-PSSNR -45056-15JETL	63	45,0	-	56	-	121	165	165	-8	0	1,1	SN..1506..
	C6-PSSNL -45056-15JETL	63	45,0	-	56	-	121	165	165	-8	0	1,1	SN..1506..

Spare Parts, Parts included in delivery

Accessories*

For size	Inducer	Inducer screw	Insert lever	Insert shim	Lever/inducer key	Lever screw	O-ring	Punch	Shim pin	Inducer
...R-12	CILS12RA-F	117.26-655	PP4713	PSN120312	3SMS795	LS0818	ORING-6.07X1.78	MP0912	RP6757	CILS12RA-R
...L-12	CILS12LA-F	117.26-655	PP4713	PSN120312	3SMS795	LS0818	ORING-6.07X1.78	MP0912	RP6757	CILS12LA-R
...R-15	CILS15RA-F	117.26-655	PP6017	PSN150412	3SMS795	LS0820	ORING-6.07X1.78	MP1519	RP8286	CILS15RA-R
...L-15	CILS15LA-F	117.26-655	PP6017	PSN150412	3SMS795	LS0820	ORING-6.07X1.78	MP1519	RP8286	CILS15LA-R

Please check availability in current price and stock-list

*To be ordered separately

Toolholders for inserts WNGA, WNMA, WNMG and WNMM



- For insert programme, see page(s) 396-399, 429-430
- γ_0° = Rake angle, λ_s° = Inclination angle
- For holder code key, see page(s) 10-11

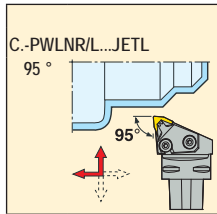
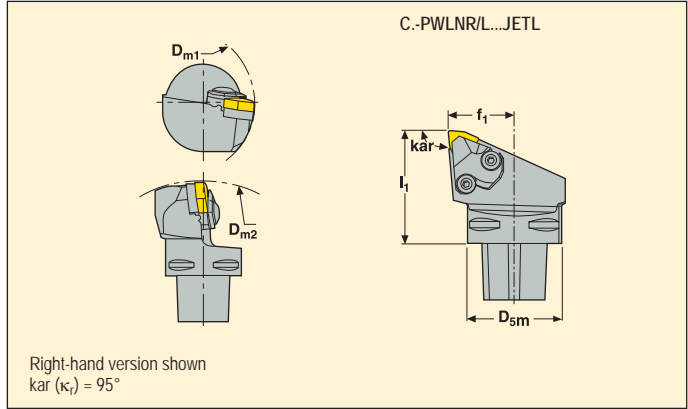

Capto size	Part No.	Dimensions in mm						γ_0°	λ_s°	KG	Icon
		D _{5m}	f ₁	l ₁	D _{m1}	D _{m2}					
C4	C4-PWLNR -27050-06JETL	40	27,0	50	75	165	-6	-6	0,5	WN..0604..	
	C4-PWLNL -27050-06JETL	40	27,0	50	75	165	-6	-6	0,5	WN..0604..	
	C4-PWLNR -27050-08JETL	40	27,0	50	75	165	-6	-6	0,4	WN..0804..	
	C4-PWLNL -27050-08JETL	40	27,0	50	75	165	-6	-6	0,4	WN..0804..	
C5	C5-PWLNR -35060-06JETL	50	35,0	60	95	165	-6	-6	0,8	WN..0604..	
	C5-PWLNL -35060-06JETL	50	35,0	60	95	165	-6	-6	0,8	WN..0604..	
	C5-PWLNR -35060-08JETL	50	35,0	60	95	165	-6	-6	0,8	WN..0804..	
	C5-PWLNL -35060-08JETL	50	35,0	60	95	165	-6	-6	0,8	WN..0804..	
C6	C6-PWLNR -45065-08JETL	63	45,0	65	121	165	-6	-6	1,3	WN..0804..	
	C6-PWLNL -45065-08JETL	63	45,0	65	121	165	-6	-6	1,3	WN..0804..	

Spare Parts, Parts included in delivery

Accessories*

For size	Inducer	Inducer key	Inducer screw	Insert lever	Insert shim	Lever/Inducer key	Lever key	Lever screw	O-ring	Punch	Shim pin	Inducer	Torque key
R-06	CILW06RA-F	3SMS795	117.26-655	PP3612	PWN060312	-	2.5SMS795	LS0616	ORING-8X1.5	MP0912	RP5152	CILW06RA-R	H00-2530
L-06	CILW06LA-F	3SMS795	117.26-655	PP3612	PWN060312	-	2.5SMS795	LS0616	ORING-8X1.5	MP0912	RP5152	CILW06LA-R	H00-2530
R-08	CILW08RA-F	-	117.26-655	PP4713	PWN080312	3SMS795	-	LS0818	ORING-8X1.5	MP0912	RP6757	CILW08RA-R	-
L-08	CILW08LA-F	-	117.26-655	PP4713	PWN080312	3SMS795	-	LS0818	ORING-8X1.5	MP0912	RP6757	CILW08LA-R	-

Please check availability in current price and stock-list

*To be ordered separately

Toolholders for inserts CCGT, CCGW, CCMT and CCMW



- For insert programme, see page(s) 343-347, 400-401, 431-432
- γ_0° = Rake angle, λ_s° = Inclination angle
- For holder code key, see page(s) 14-15

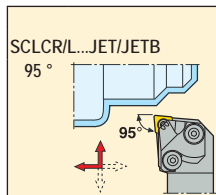
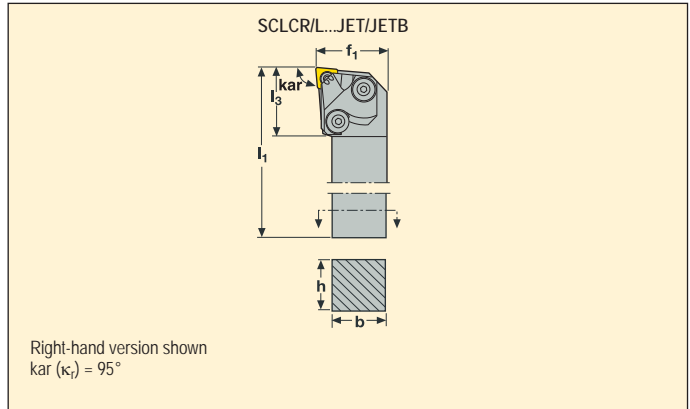

	Part No.	Dimensions in mm					γ_0°	λ_s°	KG	
		h	b	l_1	f_1	l_3				
09	SCLCR 2020K09JET	20	20	125	27,0	33	0	0	0,5	CC..09T3..
	2525M09JET	25	25	150	32,0	33	0	0	0,8	CC..09T3..
	2525K09JETB	25	25	125	32,0	31	0	0	0,7	CC..09T3..
	3225P09JET	32	25	170	32,0	33	0	0	1,1	CC..09T3..
	SCCLCL 2020K09JET	20	20	125	27,0	33	0	0	0,5	CC..09T3..
	2525M09JET	25	25	150	32,0	33	0	0	0,8	CC..09T3..
12	2525K09JETB	25	25	125	32,0	31	0	0	0,7	CC..09T3..
	3225P09JET	32	25	170	32,0	33	0	0	1,2	CC..09T3..
	SCLCR 2020K12JET	20	20	125	27,0	33	0	0	0,5	CC..1204..
	2525M12JET	25	25	150	32,0	33	0	0	0,8	CC..1204..
	3225P12JET	32	25	170	32,0	33	0	0	1,1	CC..1204..
	SCCLCL 2020K12JET	20	20	125	27,0	33	0	0	0,5	CC..1204..
	2525M12JET	25	25	150	32,0	33	0	0	0,8	CC..1204..
	3225P12JET	32	25	170	32,0	33	0	0	1,1	CC..1204..

Spare Parts, Parts included in delivery

Accessories*

For size	Inducer kit	Inducer screw	Insert/inducer key	Insert screw	Insert shim	O-ring	Plug	Shim screw	Shim key
R..09	JET-CIKC12RA-KIT	117.26-655	3SMS795/T15P	C04008-T15P	-	ORING-8X1.5	JET-P1/8-5MM	-	-
L..09	JET-CIKC12LA-KIT	117.26-655	3SMS795/T15P	C04008-T15P	-	ORING-8X1.5	JET-P1/8-5MM	-	-
R..K12	JET-CIKC12RA-KIT	117.26-655	3SMS795/T15P	C05012-T15P	123.19-621	ORING-8X1.5	JET-P1/8-5MM	CA5008	5SMS795
R..M/P12	JET-CIKC12RB-KIT	117.26-655	3SMS795/T15P	C05012-T15P	123.19-621	ORING-8X1.5	JET-P1/8-5MM	CA5008	5SMS795
L..K12	JET-CIKC12LA-KIT	117.26-655	3SMS795/T15P	C05012-T15P	123.19-621	ORING-8X1.5	JET-P1/8-5MM	CA5008	5SMS795
L..M/P12	JET-CIKC12LB-KIT	117.26-655	3SMS795/T15P	C05012-T15P	123.19-621	ORING-8X1.5	JET-P1/8-5MM	CA5008	5SMS795

Please check availability in current price and stock-list

*To be ordered separately

Toolholders for inserts CNGA, CNGG, CNMA, CNMG and CNMM



- For insert programme, see page(s) 348-355, 402, 431
- γ_0° = Rake angle, λ_s° = Inclination angle
- For holder code key, see page(s) 14-15

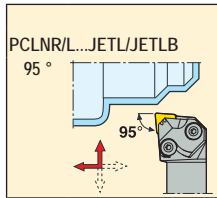
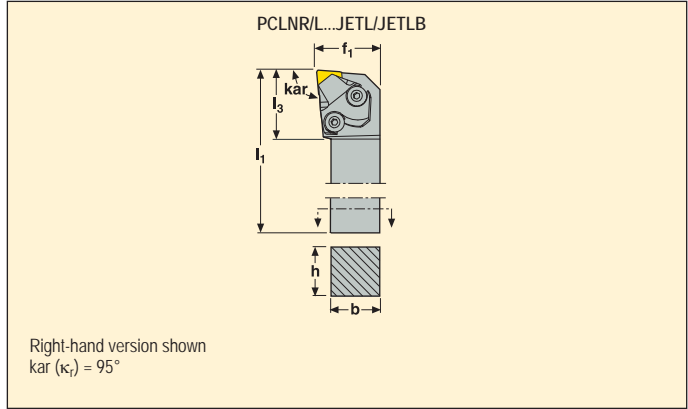

	Part No.	*	Dimensions in mm					γ_0°	λ_s°	KG	
			h	b	l_1	f_1	l_3				
12	PCLNR 2020K12JETL	Duo	20	20	125	27,0	34	-6	-6	0,5	CN..1204..
	2525M12JETL	Duo	25	25	150	32,0	34	-6	-6	0,8	CN..1204..
	2525K12JETLB	Duo	25	25	125	32,0	34	-6	-6	0,7	CN..1204..
	3225P12JETL	Duo	32	25	170	32,0	34	-6	-6	1,2	CN..1204..
	PCLNL 2020K12JETL	Duo	20	20	125	27,0	34	-6	-6	0,5	CN..1204..
	2525M12JETL	Duo	25	25	150	32,0	34	-6	-6	0,8	CN..1204..
	2525K12JETLB	Duo	25	25	125	32,0	34	-6	-6	0,7	CN..1204..
	3225P12JETL	Duo	32	25	170	32,0	34	-6	-6	1,2	CN..1204..
16	PCLNR 3225P16JETL	Duo	32	25	170	32,0	38	-6	-6	1,1	CN..1606..
	3232P16JETL	Duo	32	32	170	40,0	36	-6	-6	1,4	CN..1606..
	PCLNL 3225P16JETL	Duo	32	25	170	32,0	38	-6	-6	1,1	CN..1606..
	3232P16JETL	Duo	32	32	170	40,0	36	-6	-6	1,4	CN..1606..

*Jetstream Tooling Duo, see page(s) 27-29

Spare Parts, Parts included in delivery

Accessories*

For size	Inducer	Inducer screw	Insert lever	Insert shim	Lever/inducer key	Lever screw	O-ring	Punch	Shim pin	Inducer	Plug
R-12	CILC12RA-F	117.26-655	PP4713	PCN120308	3SMS795	LS0818	ORING-8X1.5	MP0912	RP6757	CILC12RA-R	P6SS4X8
L-12	CILC12LA-F	117.26-655	PP4713	PCN120308	3SMS795	LS0818	ORING-8X1.5	MP0912	RP6757	CILC12LA-R	P6SS4X8
R3225-16	CILC16RA-F	117.26-655	PP6017	PCN160412	3SMS795	LS0820	ORING-8X1.5	MP1519	RP8286	CILC16RA-R	P6SS4X8
R3232-16	CILC16RA-F	117.26-655	PP6017	PCN160412	3SMS795	LS0820	ORING-8X1.5	MP1519	RP8286	CILC16RA-R	JET-P1/8-5MM
L3225-16	CILC16LA-F	117.26-655	PP6017	PCN160412	3SMS795	LS0820	ORING-8X1.5	MP1519	RP8286	CILC16LA-R	P6SS4X8
L3232-16	CILC16LA-F	117.26-655	PP6017	PCN160412	3SMS795	LS0820	ORING-8X1.5	MP1519	RP8286	CILC16LA-R	JET-P1/8-5MM

Please check availability in current price and stock-list

*To be ordered separately

Toolholders for inserts RCMT



- For insert programme, see page(s) 369
- γ_0° = Rake angle, λ_s° = Inclination angle
- For holder code key, see page(s) 14-15

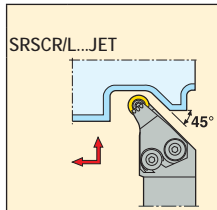
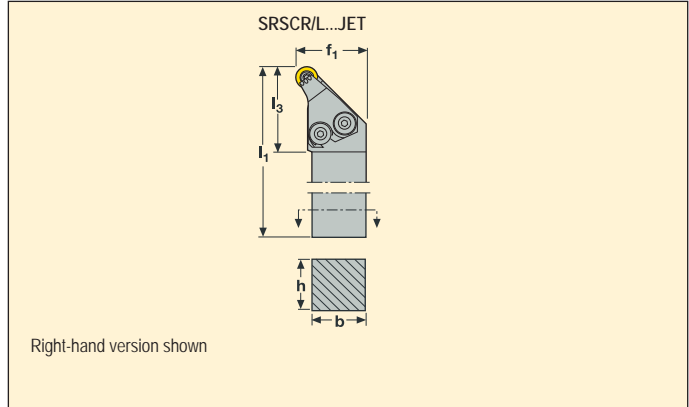

	Part No.	Dimensions in mm					γ_0°	λ_s°	KG	
		h	b	l_1	f_1	l_3				
10	SRSCR 2020K10JET	20	20	125	28,0	39	0	0	0,5	RCMT10T3...
	2525M10JET	25	25	150	32,0	39	0	0	0,7	RCMT10T3...
	3225P10JET	32	25	170	32,0	39	0	0	1,1	RCMT10T3...
	SRSCCL 2020K10JET	20	20	125	28,0	39	0	0	0,5	RCMT10T3...
	2525M10JET	25	25	150	32,0	39	0	0	0,7	RCMT10T3...
	3225P10JET	32	25	170	32,0	39	0	0	1,1	RCMT10T3...
12	SRSCR 2020K12JET	20	20	125	30,0	40	0	0	0,5	RCMT1204..
	2525M12JET	25	25	150	32,0	40	0	0	0,7	RCMT1204..
	3225P12JET	32	25	170	32,0	40	0	0	1,1	RCMT1204..
	SRSCCL 2020K12JET	20	20	125	30,0	40	0	0	0,5	RCMT1204..
	2525M12JET	25	25	150	32,0	40	0	0	0,7	RCMT1204..
	3225P12JET	32	25	170	32,0	40	0	0	1,1	RCMT1204..

Spare Parts, Parts included in delivery

Accessories*

For size	Inducer kit	Inducer screw	Insert/inducer key	Insert screw	Insert shim	O-ring	Plug	Shim screw	Shim key
R-10	JET-CIKR00RA-KIT	117.26-655	3SMS795/T15P	C03510-T15P	111.19-620	ORING-6.07X1.78	JET-P1/8-5MM	CA3510	9/64SMS875
L-10	JET-CIKR00LA-KIT	117.26-655	3SMS795/T15P	C03510-T15P	111.19-620	ORING-6.07X1.78	JET-P1/8-5MM	CA3510	9/64SMS875
R-12	JET-CIKR00RA-KIT	117.26-655	3SMS795/T15P	C03510-T15P	111.19-621	ORING-6.07X1.78	JET-P1/8-5MM	CA3510	9/64SMS875
L-12	JET-CIKR00LA-KIT	117.26-655	3SMS795/T15P	C03510-T15P	111.19-621	ORING-6.07X1.78	JET-P1/8-5MM	CA3510	9/64SMS875

Please check availability in current price and stock-list

*To be ordered separately

Toolholders for inserts CCGT, CCGW, CCMT and CCMW



- For insert programme, see page(s) 343-347, 400-401, 431-432
- γ_0 = Rake angle, λ_s = Inclination angle
- For holder code key, see page(s) 10-11

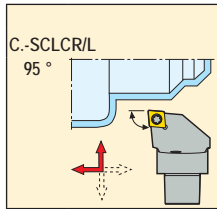
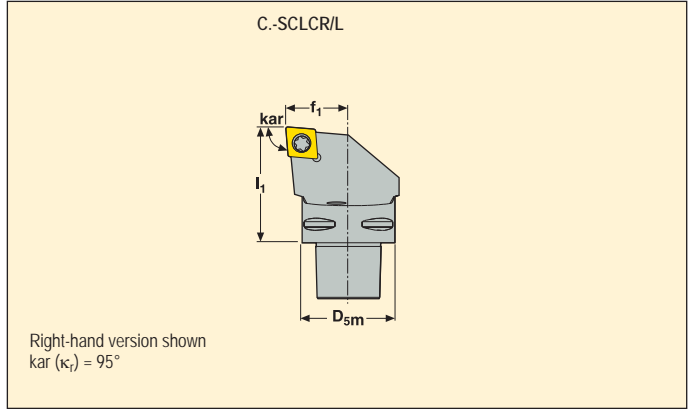

Capto size	Part No.	Dimensions in mm			γ_0 °	λ_s °	KG	Key
		D _{sm}	f ₁	l ₁				
C3	C3-SCLCR -22040-09	32	22,0	40	0	0	0,3	CC..09T3..
	C3-SCLCL -22040-09	32	22,0	40	0	0	0,3	CC..09T3..
	C3-SCLCR -22040-12	32	22,0	40	0	0	0,3	CC..1204..
	C3-SCLCL -22040-12	32	22,0	40	0	0	0,3	CC..1204..
C4	C4-SCLCR -27050-09	40	27,0	50	0	0	0,5	CC..09T3..
	C4-SCLCL -27050-09	40	27,0	50	0	0	0,5	CC..09T3..
	C4-SCLCR -27050-12	40	27,0	50	0	0	0,5	CC..1204..
	C4-SCLCL -27050-12	40	27,0	50	0	0	0,5	CC..1204..
C5	C5-SCLCR -35060-09	50	35,0	60	0	0	0,8	CC..09T3..
	C5-SCLCL -35060-09	50	35,0	60	0	0	0,8	CC..09T3..
	C5-SCLCR -35060-12	50	35,0	60	0	0	0,7	CC..1204..
	C5-SCLCL -35060-12	50	35,0	60	0	0	0,7	CC..1204..
C6	C6-SCLCR -45065-09	63	45,0	65	0	0	1,4	CC..09T3..
	C6-SCLCL -45065-09	63	45,0	65	0	0	1,4	CC..09T3..
	C6-SCLCR -45065-12	63	45,0	65	0	0	1,4	CC..1204..
	C6-SCLCL -45065-12	63	45,0	65	0	0	1,4	CC..1204..

Spare Parts, Parts included in delivery

For size	Insert key	Insert screw	Insert shim	Shim screw	Shim key
-09	T15P-2	C03512-T15P	SCN090308	CA3507	9/64SMS875
-12	T15P-2	C04014-T15P	SCN12T308	CA4010	4SMS795

Accessories, to be ordered separately

Please check availability in current price and stock-list

Toolholders for inserts CNGA, CNGG, CNMA, CNMG and CNMM



- For insert programme, see page(s) 348-355
- γ_0° = Rake angle, λ_s° = Inclination angle
- For holder code key, see page(s) 10-11

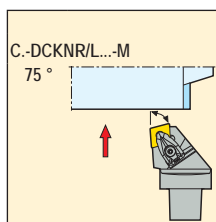
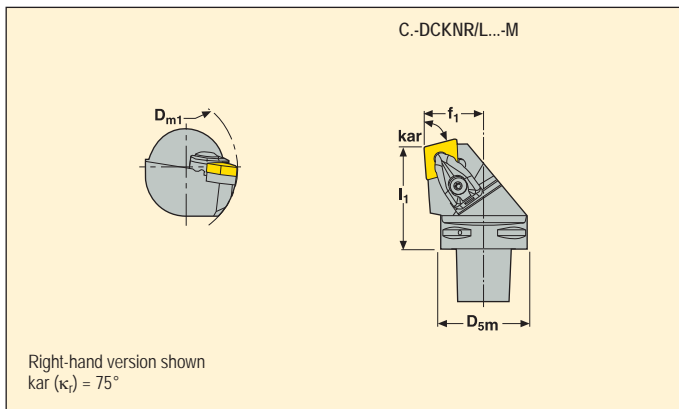

Capto size	Part No.	Dimensions in mm				γ_0°	λ_s°	KG	
		D _{sm}	f ₁	I ₁	D _m				
C4	C4-DCKNR -27050-09-M	40	27,0	50	75	-6	-6	0,5	CN..0903..
	C4-DCKNL -27050-09-M	40	27,0	50	75	-6	-6	0,5	CN..0903..
	C4-DCKNR -27050-12-M	40	27,0	50	110	-6	-6	0,5	CN..1204..
	C4-DCKNL -27050-12-M	40	27,0	50	110	-6	-6	0,5	CN..1204..
	C4-DCKNR -27050-16-M	40	27,0	50	125	-6	-6	0,5	CN..1606..
	C4-DCKNL -27050-16-M	40	27,0	50	125	-6	-6	0,5	CN..1606..
C5	C5-DCKNR -35060-12-M	50	35,0	60	110	-6	-6	0,9	CN..1204..
	C5-DCKNL -35060-12-M	50	35,0	60	110	-6	-6	0,9	CN..1204..
	C5-DCKNR -35060-16-M	50	35,0	60	125	-6	-6	0,9	CN..1606..
	C5-DCKNL -35060-16-M	50	35,0	60	125	-6	-6	0,9	CN..1606..
	C5-DCKNR -35060-19-M	50	35,0	60	95	-6	-6	0,8	CN..1906..
	C5-DCKNL -35060-19-M	50	35,0	60	95	-6	-6	0,8	CN..1906..

Spare Parts, Parts included in delivery

Accessories*

For size	Clamp pin	Clamp screw	Floating wedge clamp	Insert shim	Shim/clamp key	Shim screw	Spring	Clamp kit
-09	FP1508	L84017-T09P	CD09-S	DCN090310	T09P-2	C03007-T09P	S5608	CD09-S09
-12	FP2012	L85021-T15P	CD12-S	DCN120616	T15P-2	C04008-T15P	S6912	CD12-S12
-16	FP2012	L86026-T20P	CD16-S	DCN160616	T20P-7L	C05010-T20P	S7010	CD16-S16
-19	FP2012	L86026-T20P	CD19-S	DCN190416	T20P-7L	C05010-T20P	S7010	CD19-S19

Please check availability in current price and stock-list

*To be ordered separately
Shim DCN120416 for insert CN..1206.., to be ordered separately

Toolholders for inserts CNGA, CNGG, CNMA, CNMG and CNMM



- For insert programme, see page(s) 348-355
- γ_0° = Rake angle, λ_s° = Inclination angle
- For holder code key, see page(s) 10-11

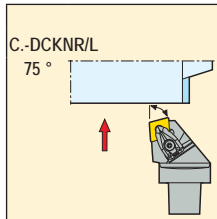
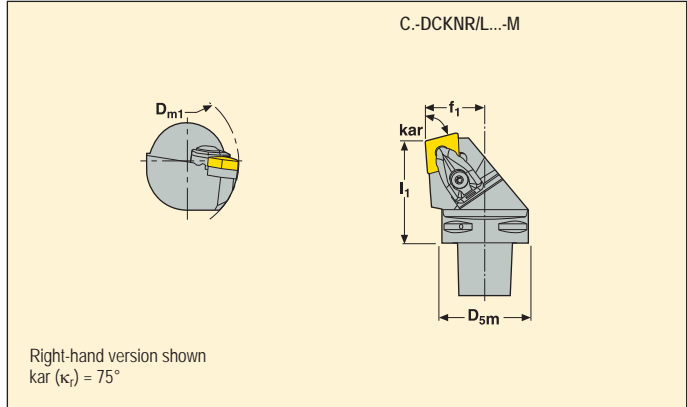

Capto size	Part No.	Dimensions in mm					γ_0°	λ_s°	KG	
		D _{5m}	f ₁	l ₁	D _{m1}					
C6	C6-DCKNR -45065-12-M	63	45,0	65	110	-6	-6	1,4	CN..1204..	
	C6-DCKNL -45065-12-M	63	45,0	65	110	-6	-6	1,4	CN..1204..	
	C6-DCKNR -45065-16-M	63	45,0	65	125	-6	-6	1,4	CN..1606..	
	C6-DCKNL -45065-16-M	63	45,0	65	125	-6	-6	1,4	CN..1606..	
	C6-DCKNR -45065-19-M	63	45,0	65	81	-6	-6	1,4	CN..1906..	
	C6-DCKNL -45065-19-M	63	45,0	65	81	-6	-6	1,4	CN..1906..	

Spare Parts, Parts included in delivery

For size	Clamp pin	Clamp screw	Floating wedge clamp	Insert shim	Shim/clamp key	Shim screw	Spring	Clamp kit
-12	FP2012	L85021-T15P	CD12-S	DCN120616	T15P-2	C04008-T15P	S6912	CD12-S12
-16	FP2012	L86026-T20P	CD16-S	DCN160616	T20P-7L	C05010-T20P	S7010	CD16-S16
-19	FP2012	L86026-T20P	CD19-S	DCN190416	T20P-7L	C05010-T20P	S7010	CD19-S19

Accessories*

Please check availability in current price and stock-list

*To be ordered separately
Shim DCN120416 for insert CN..1206.., to be ordered separately

Toolholders for inserts CNGA, CNGG, CNMA, CNMG and CNMM



- For insert programme, see page(s) 348-355, 402, 431
- γ_0° = Rake angle, λ_s° = Inclination angle
- For holder code key, see page(s) 10-11

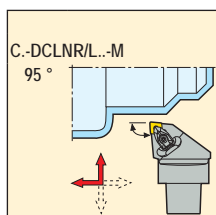
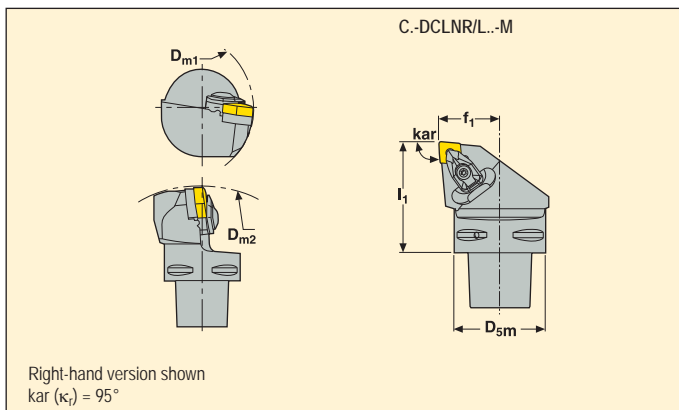

Capto size	Part No.	Dimensions in mm					γ_0°	λ_s°	KG	Icon	
		D _{sm}	f ₁	I ₁	D _{m1}	D _{m2}					
C4	C4-DCLNR -27050-09-M	40	27,0	50	60	140	-6	-6	0,5	CN..0903..	
	C4-DCLNL -27050-09-M	40	27,0	50	60	140	-6	-6	0,5	CN..0903..	
	C4-DCLNR -27050-12-M	40	27,0	50	110	140	-6	-6	0,4	CN..1204..	
	C4-DCLNL -27050-12-M	40	27,0	50	110	140	-6	-6	0,4	CN..1204..	
	C4-DCLNR -27055-16-M	40	27,0	55	125	155	-6	-6	0,5	CN..1606..	
	C4-DCLNL -27055-16-M	40	27,0	55	125	155	-6	-6	0,5	CN..1606..	
C5	C5-DCLNR -35060-12-M	50	35,0	60	110	165	-6	-6	0,8	CN..1204..	
	C5-DCLNL -35060-12-M	50	35,0	60	110	165	-6	-6	0,8	CN..1204..	
	C5-DCLNR -35060-16-M	50	35,0	60	125	165	-6	-6	0,8	CN..1606..	
	C5-DCLNL -35060-16-M	50	35,0	60	125	165	-6	-6	0,8	CN..1606..	
	C5-DCLNR -35060-19-M	50	35,0	60	80	165	-6	-6	0,8	CN..1906..	
	C5-DCLNL -35060-19-M	50	35,0	60	80	165	-6	-6	0,8	CN..1906..	

Spare Parts, Parts included in delivery

For size	Clamp pin	Clamp screw	Floating wedge clamp	Insert shim	Shim/clamp key	Shim screw	Spring	Clamp kit
-09	FP1508	L84017-T09P	CD09-S	DCN090310	T09P-2	C03007-T09P	S5608	CD09-S09
-12	FP2012	L85021-T15P	CD12-S	DCN120616	T15P-2	C04008-T15P	S6912	CD12-S12
-16	FP2012	L86026-T20P	CD16-S	DCN160616	T20P-7L	C05010-T20P	S7010	CD16-S16
-19	FP2012	L86026-T20P	CD19-S	DCN190416	T20P-7L	C05010-T20P	S7010	CD19-S19

Accessories*

Please check availability in current price and stock-list

*To be ordered separately
Shim DCN120416 for insert CN..1206.., to be ordered separately

Toolholders for inserts CNGA, CNGG, CNMA, CNMG and CNMM



- For insert programme, see page(s) 348-355
- γ_0° = Rake angle, λ_s° = Inclination angle
- For holder code key, see page(s) 10-11

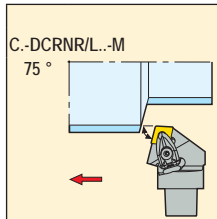
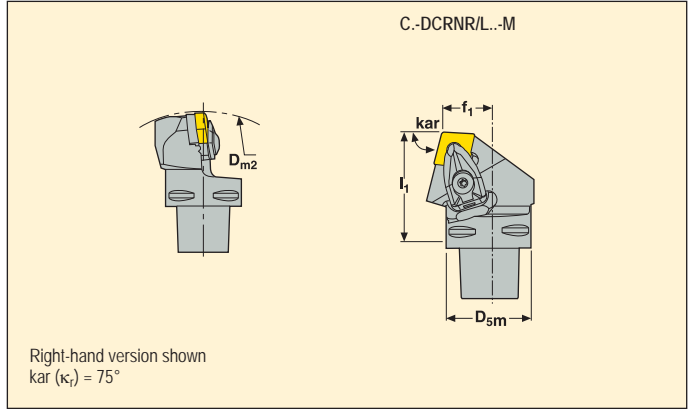

Capto size	Part No.	Dimensions in mm				γ_0°	λ_s°	KG	
		D _{sm}	f ₁	l ₁	D _{m2}				
C4	C4-DCRNR -22050-12-M	40	22,0	50	140	-6	-6	0,4	CN..1204..
	C4-DCRNL -22050-12-M	40	22,0	50	140	-6	-6	0,4	CN..1204..
	C4-DCRNR -22055-16-M	40	22,0	55	165	-6	-6	0,5	CN..1606..
	C4-DCRNL -22055-16-M	40	22,0	55	165	-6	-6	0,5	CN..1606..
C5	C5-DCRNR -27060-12-M	50	27,0	60	165	-6	-6	0,8	CN..1204..
	C5-DCRNL -27060-12-M	50	27,0	60	165	-6	-6	0,8	CN..1204..
	C5-DCRNR -27060-16-M	50	27,0	60	165	-6	-6	0,8	CN..1606..
	C5-DCRNL -27060-16-M	50	27,0	60	165	-6	-6	0,8	CN..1606..
	C5-DCRNR -27060-19-M	50	27,0	60	165	-6	-6	0,9	CN..1906..
	C5-DCRNL -27060-19-M	50	27,0	60	165	-6	-6	0,9	CN..1906..
C6	C6-DCRNR -35065-12-M	63	35,0	65	190	-6	-6	1,2	CN..1204..
	C6-DCRNL -35065-12-M	63	35,0	65	190	-6	-6	1,2	CN..1204..
	C6-DCRNR -35065-16-M	63	35,0	65	190	-6	-6	1,3	CN..1606..
	C6-DCRNL -35065-16-M	63	35,0	65	190	-6	-6	1,3	CN..1606..
	C6-DCRNR -35065-19-M	63	35,0	65	190	-6	-6	1,3	CN..1906..
	C6-DCRNL -35065-19-M	63	35,0	65	190	-6	-6	1,3	CN..1906..

Spare Parts, Parts included in delivery

For size	Clamp pin	Clamp screw	Floating wedge clamp	Insert shim	Shim/clamp key	Shim screw	Spring	Clamp kit
-12	FP2012	L85021-T15P	CD12-S	DCN120616	T15P-2	C04008-T15P	S6912	CD12-S12
-16	FP2012	L86026-T20P	CD16-S	DCN160616	T20P-7L	C05010-T20P	S7010	CD16-S16
-19	FP2012	L86026-T20P	CD19-S	DCN190416	T20P-7L	C05010-T20P	S7010	CD19-S19

Accessories*

Please check availability in current price and stock-list

*To be ordered separately
Shim DCN120416 for insert CN..1206.., to be ordered separately

Toolholders for PCBN inserts CNGN and CNMN



- For insert programme, see page(s) 403, 436
- γ_0° = Rake angle, λ_s° = Inclination angle
- For holder code key, see page(s) 10-11

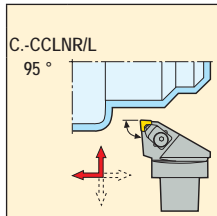
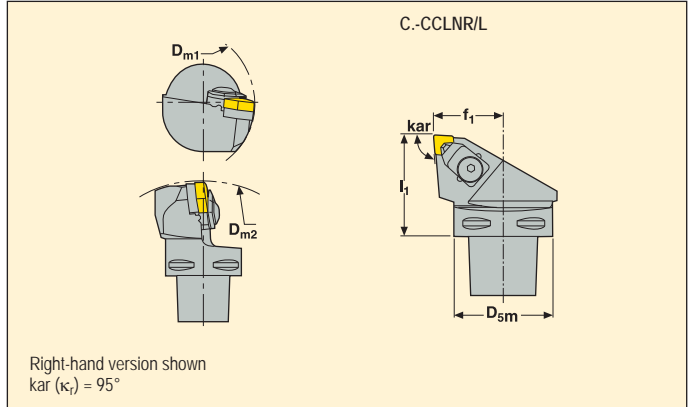

Capto size	Part No.	Dimensions in mm						γ_0°	λ_s°	KG	Insert
		D _{5m}	f ₁	l ₁	D _{m1}	D _{m2}					
C4	09	C4-CCLNR -27050-09	40	27,0	50	75	165	-6	-6	0,5	CN.N0903..
		C4-CCLNL -27050-09	40	27,0	50	75	165	-6	-6	0,5	CN.N0903..
	12	C4-CCLNR -27050-12	40	27,0	50	75	165	-6	-6	0,5	CN.N1204..
		C4-CCLNL -27050-12	40	27,0	50	75	165	-6	-6	0,5	CN.N1204..
C5	09	C5-CCLNR -35060-09	50	35,0	60	95	165	-6	-6	0,8	CN.N0903..
		C5-CCLNL -35060-09	50	35,0	60	95	165	-6	-6	0,8	CN.N0903..
	12	C5-CCLNR -35060-12	50	35,0	60	95	165	-6	-6	0,8	CN.N1204..
		C5-CCLNL -35060-12	50	35,0	60	95	165	-6	-6	0,8	CN.N1204..
C6	12	C6-CCLNR -45065-12	63	45,0	65	121	165	-6	-6	1,3	CN.N1204..
		C6-CCLNL -45065-12	63	45,0	65	121	165	-6	-6	1,3	CN.N1204..

Spare Parts, Parts included in delivery

For size	Cantilever clamp	Clamp key	Insert shim	Pressure plate	Shim screw	Shim key
-09	CC17P-09	4SMS795	CCN090412	P1311-09	174.10-652-T07P	T07P-2
-12	CC17P	4SMS795	CCN120312	P1311	F94009-T09P	T09P-2

Accessories*

Please check availability in current price and stock-list

*To be ordered separately

Toolholders for inserts DCGT, DCMT, DCMW and DCMX



- For insert programme, see page(s) 356-359, 404, 433
- γ_0° = Rake angle, λ_s° = Inclination angle
- For holder code key, see page(s) 10-11

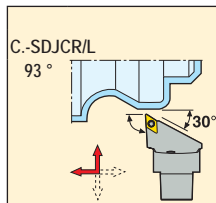
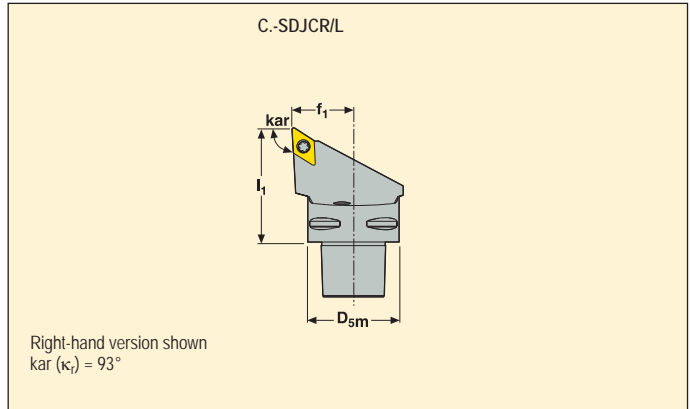

Capto size	Part No.	Dimensions in mm			γ_0°	λ_s°	KG	Key
		D _{5m}	f ₁	I ₁				
C3	11 C3-SDJCR -22040-11	32	22,0	40	0	0	0,3	DC..11T3..
	C3-SDJCL -22040-11	32	22,0	40	0	0	0,3	DC..11T3..
C4	07 C4-SDJCR -27050-07	40	27,0	50	0	0	0,5	DC..0702..
	C4-SDJCL -27050-07	40	27,0	50	0	0	0,5	DC..0702..
	11 C4-SDJCR -27050-11	40	27,0	50	0	0	0,4	DC..11T3..
	C4-SDJCL -27050-11	40	27,0	50	0	0	0,4	DC..11T3..
C5	11 C5-SDJCR -35060-11	50	35,0	60	0	0	0,7	DC..11T3..
	C5-SDJCL -35060-11	50	35,0	60	0	0	0,7	DC..11T3..
C6	11 C6-SDJCR -45065-11	63	45,0	65	0	0	1,1	DC..11T3..
	C6-SDJCL -45065-11	63	45,0	65	0	0	1,1	DC..11T3..

Spare Parts, Parts included in delivery

For size	Insert key	Insert screw	Insert shim	Shim screw	Shim key
-07	T07P-2	C02506-T07P	-	-	-
-11	T15P-2	C03512-T15P	126.19-620	CA3507	9/64SMS875

Accessories, to be ordered separately

Please check availability in current price and stock-list

Toolholders for inserts DNGA, DNGG, DNGM, DNMA, DNMG, DNMM and DNMX



- For insert programme, see page(s) 359-365, 406
- γ_0° = Rake angle, λ_s° = Inclination angle
- For holder code key, see page(s) 10-11

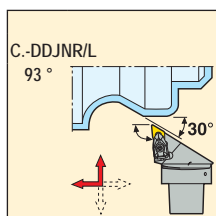
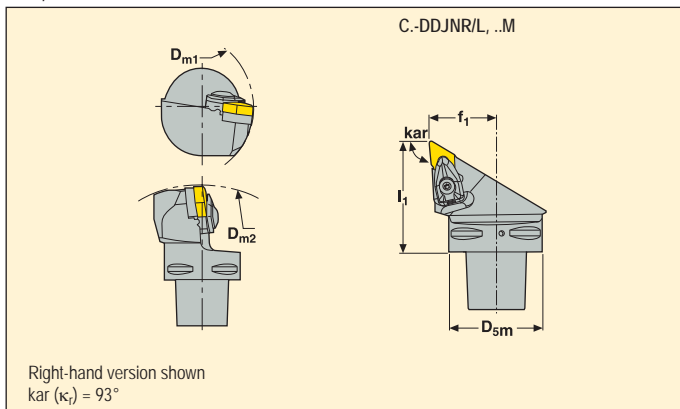

Capto size	Part No.	Dimensions in mm					γ_0°	λ_s°	KG	Key
		D_{sm}	f_1	I_1	D_{m1}	D_{m2}				
C4	C4-DDJNR -27050-11-M	40	27,0	50	60	140	-6	-7	0,4	DN..1104..
	C4-DDJNL -27050-11-M	40	27,0	50	60	140	-6	-7	0,4	DN..1104..
	C4-DDJNR -27055-15-M	40	27,0	55	110	145	-6	-7	0,4	DN..1506..
	C4-DDJNL -27055-15-M	40	27,0	55	110	145	-6	-7	0,4	DN..1506..
C5	C5-DDJNR -35060-11-M	50	35,0	60	65	165	-6	-7	0,7	DN..1104..
	C5-DDJNL -35060-11-M	50	35,0	60	65	165	-6	-7	0,7	DN..1104..
	C5-DDJNR -35060-15-M	50	35,0	60	110	165	-6	-7	0,7	DN..1506..
	C5-DDJNL -35060-15-M	50	35,0	60	110	165	-6	-7	0,7	DN..1506..
C6	C6-DDJNR -45065-11-M	63	45,0	65	81	190	-6	-7	1,1	DN..1104..
	C6-DDJNL -45065-11-M	63	45,0	65	81	190	-6	-7	1,1	DN..1104..
	C6-DDJNR -45065-15-M	63	45,0	65	110	190	-6	-7	1,1	DN..1506..
	C6-DDJNL -45065-15-M	63	45,0	65	110	190	-6	-7	1,1	DN..1506..
C8	C8-DDJNR -55080-15	80	55,0	80	110	250	-6	-7	2,2	DN..1506..
	C8-DDJNL -55080-15	80	55,0	80	110	250	-6	-7	2,2	DN..1506..

Spare Parts, Parts included in delivery

Accessories*

For size	Clamp pin	Clamp screw	Floating wedge clamp	Insert shim	Shim/clamp key	Shim screw	Spring	Clamp kit
-11	FP1508	L84017-T09P	CD09-S	DDN110310	T09P-2	C03007-T09P	S5608	CD09-S09
-15	FP2012	L85021-T15P	CD12-S	DDN150416	T15P-2	C04008-T15P	S6912	CD12-S12

Please check availability in current price and stock-list

*To be ordered separately
Shim DDN150616 for insert DN..1504.., to be ordered separately

Toolholders for inserts DNGA, DNGG, DNGM, DNMA, DNMG, DNMM and DNMX



- For insert programme, see page(s) 359-365, 406
- γ_0° = Rake angle, λ_s° = Inclination angle
- For holder code key, see page(s) 10-11

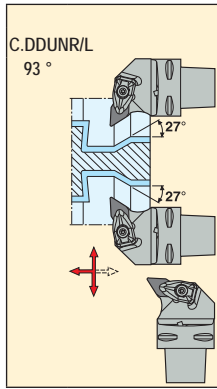
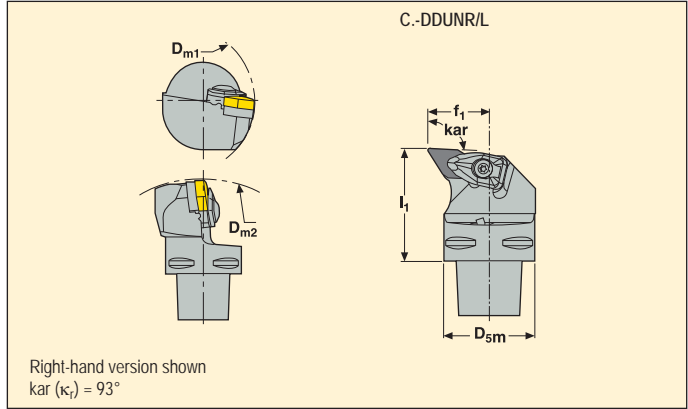

Capto size	Part No.	Dimensions in mm					γ_0°	λ_s°	KG	Insert
		D _{5m}	f ₁	l ₁	D _{m1}	D _{m2}				
C4	C4-DDUNR -27050-15	40	27,0	50	110	140	-6	-7	0,5	DN..1506..
	C4-DDUNL -27050-15	40	27,0	50	110	140	-6	-7	0,5	DN..1506..
C5	C5-DDUNR -35060-15	50	35,0	60	110	165	-6	-7	0,8	DN..1506..
	C5-DDUNL -35060-15	50	35,0	60	110	165	-6	-7	0,8	DN..1506..
C6	C6-DDUNR -45065-15	63	45,0	65	110	190	-6	-7	1,3	DN..1506..
	C6-DDUNL -45065-15	63	45,0	65	110	190	-6	-7	1,3	DN..1506..
C8	C8-DDUNR -55080-15	80	80,0	80	110	250	-6	-7	2,6	DN..1506..
	C8-DDUNL -55080-15	80	80,0	80	110	250	-6	-7	2,6	DN..1506..

Spare Parts, Parts included in delivery

Accessories*

For size	Clamp pin	Clamp screw	Floating wedge clamp	Insert shim	Shim/clamp key	Shim screw	Spring	Clamp kit
-15	FP2012	L85021-T15P	CD12-S	DDN150416	T15P-7	C04008-T15P	S6912	CD12-S12

Please check availability in current price and stock-list

*To be ordered separately
Shim DDN150616 for insert DN..1504.., to be ordered separately

Toolholders for inserts DNGA, DNGG, DNGM, DNMA, DNMM and DNMM



- For insert programme, see page(s) 359-365, 406-407
- γ_0° = Rake angle, λ_s° = Inclination angle
- For holder code key, see page(s) 10-11

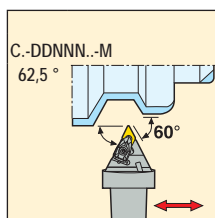
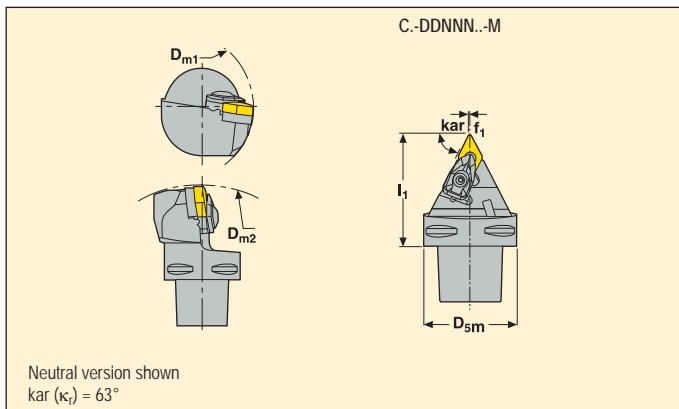

Capto size	Part No.	Dimensions in mm				γ_0°	λ_s°	KG	Key
		D_{sm}	f_1	I_1	D_{m2}				
C4	11 C4-DDN...-00050-11-M	40	0,5	50	140	-5	-9	0,4	DN..1104..
	15 C4-DDN...-00055-15-M	40	0,5	55	145	-5	-9	0,4	DN..1506..
C5	11 C5-DDN...-00060-11-M	50	0,5	60	165	-5	-9	0,6	DN..1104..
	15 C5-DDN...-00060-15-M	50	0,5	60	165	-5	-9	0,6	DN..1506..
C6	11 C6-DDN...-00065-11-M	63	0,5	65	165	-5	-9	1,0	DN..1104..
	15 C6-DDN...-00065-15-M	63	0,5	65	190	-5	-9	1,0	DN..1506..

Spare Parts, Parts included in delivery

Accessories*

For size	Clamp pin	Clamp screw	Floating wedge clamp	Insert shim	Shim/clamp key	Shim screw	Spring	Clamp kit
-11	FP1508	L84017-T09P	CD09-S	DDN110310	T09P-2	C03007-T09P	S5608	CD09-S09
-15	FP2012	L85021-T15P	CD12-S	DDN150416	T15P-2	C04008-T15P	S6912	CD12-S12

Please check availability in current price and stock-list

*To be ordered separately
Shim DDN150616 for insert DN..1504.., to be ordered separately

Toolholders for inserts RCMT



- For insert programme, see page(s) 369
- γ_o° = Rake angle, λ_s° = Inclination angle
- For holder code key, see page(s) 10-11

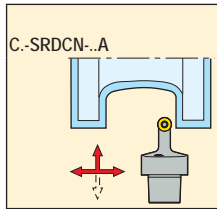
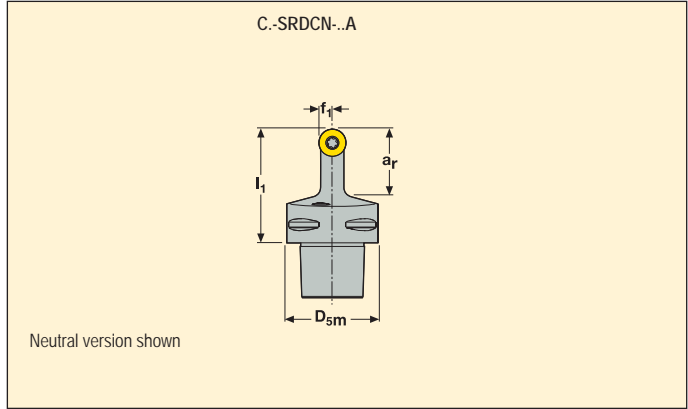

Capto size		Part No.	Dimensions in mm				γ_o°	λ_s°		KG	
			D _{5m}	f ₁	l ₁	a _r					
C4	06	C4-SRDCN -00050-06A	40	3,0	50	12	0	0	0,4	RCMT0602..	
	08	C4-SRDCN -00050-08A	40	4,0	50	16	0	0	0,3	RCMT0803..	
	10	C4-SRDCN -00050-10A	40	5,0	50	25	0	0	0,4	RCMT10T3..	
	12	C4-SRDCN -00050-12A	40	6,0	50	28	0	0	0,3	RCMT1204..	

Spare Parts, Parts included in delivery

For size	Insert key	Insert screw	Insert shim	Shim screw	Shim key
-06	T07P-2	C02506-T07P	-	-	-
-08	T09P-2	C03007-T09P	-	-	-
-10	T15P-2	C03510-T15P	111.19-620	CA3507	9/64SMS875
-12	T15P-2	C03512-T15P	111.19-621	CA3507	9/64SMS875

Accessories, to be ordered separately

Please check availability in current price and stock-list

Toolholders for inserts RCMT



- For insert programme, see page(s) 369
- γ_0° = Rake angle, λ_s° = Inclination angle
- For holder code key, see page(s) 10-11

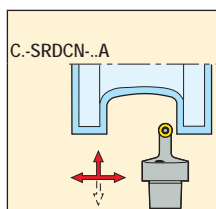
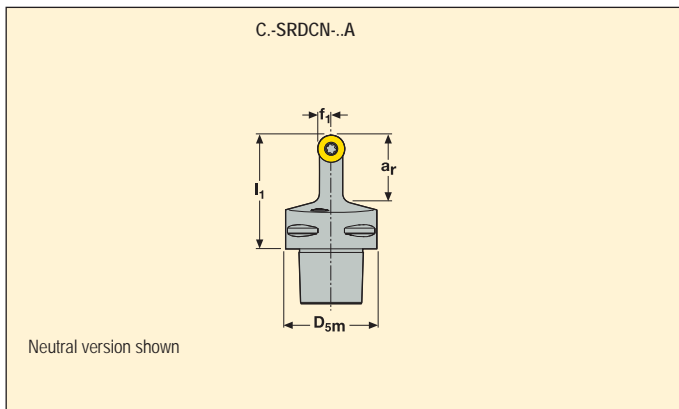

Capto size	Part No.	Dimensions in mm				γ_0°	λ_s°	KG	Insert
		D _{5m}	f ₁	l ₁	a _r				
C5	06 C5-SRDCN -00060-06A	50	3,0	60	12	0	0	0,7	RCMT0602..
	08 C5-SRDCN -00060-08A	50	4,0	60	16	0	0	0,7	RCMT0803..
	10 C5-SRDCN -00060-10A	50	5,0	60	25	0	0	0,8	RCMT10T3..
	12 C5-SRDCN -00060-12A	50	6,0	60	28	0	0	0,6	RCMT1204..
	16 C5-SRDCN -00060-16A	50	8,0	60	35	0	0	0,6	RCMT1606..
C6	10 C6-SRDCN -00065-10A	63	5,0	65	25	0	0	1,1	RCMT10T3..
	12 C6-SRDCN -00065-12A	63	6,0	65	28	0	0	1,0	RCMT1204..
	16 C6-SRDCN -00065-16A	63	8,0	65	35	0	0	0,9	RCMT1606..

Spare Parts, Parts included in delivery

For size	Insert key	Insert screw	Insert shim	Shim screw	Shim key
-06	T07P-2	C02506-T07P	-	-	-
-08	T09P-2	C03007-T09P	-	-	-
-10	T15P-2	C03510-T15P	111.19-620	CA3507	9/64SMS875
-12	T15P-2	C03512-T15P	111.19-621	CA3507	9/64SMS875
-16	T20P-7	C05013-T20P	SRN160400	CA5010	5SMS795

Accessories, to be ordered separately

Please check availability in current price and stock-list

Toolholders for inserts RCMT



- For insert programme, see page(s) 369
- γ_o° = Rake angle, λ_s° = Inclination angle
- For holder code key, see page(s) 10-11

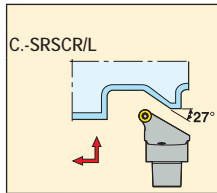
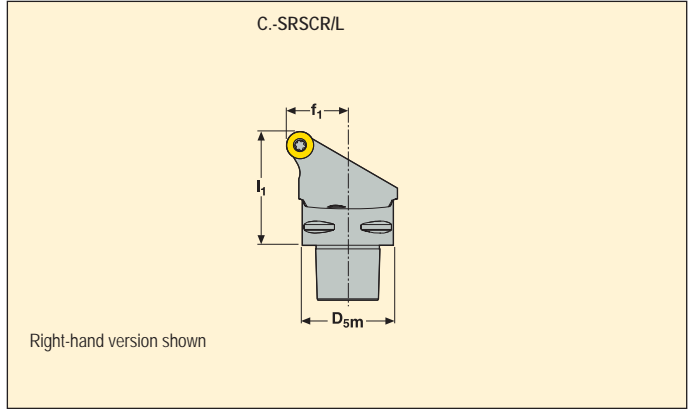

Capto size	Part No.	Dimensions in mm			γ_o°	λ_s°	KG	Insert
		D _{5m}	f ₁	l ₁				
C4	C4-SRSCR -27050-06	40	27,0	50	0	0	0,4	RCMT0602..
	C4-SRSCCL -27050-06	40	27,0	50	0	0	0,4	RCMT0602..
08	C4-SRSCR -27050-08	40	27,0	50	0	0	0,5	RCMT0803..
	C4-SRSCCL -27050-08	40	27,0	50	0	0	0,5	RCMT0803..
10	C4-SRSCR -27050-10	40	27,0	50	0	0	0,4	RCMT10T3..
	C4-SRSCCL -27050-10	40	27,0	50	0	0	0,4	RCMT10T3..
12	C4-SRSCR -27050-12	40	27,0	50	0	0	0,4	RCMT1204..
	C4-SRSCCL -27050-12	40	27,0	50	0	0	0,4	RCMT1204..

Spare Parts, Parts included in delivery

For size	Insert key	Insert screw	Insert shim	Shim screw	Shim key
-06	T07P-2	C02506-T07P	-	-	-
-08	T09P-2	C03007-T09P	-	-	-
-10	T15P-2	C03510-T15P	111.19-620	CA3507	9/64SMS875
-12	T15P-2	C03512-T15P	111.19-621	CA3507	9/64SMS875

Accessories, to be ordered separately

Please check availability in current price and stock-list

Toolholders for inserts RCMT



- For insert programme, see page(s) 369
- γ_0° = Rake angle, λ_s° = Inclination angle
- For holder code key, see page(s) 10-11

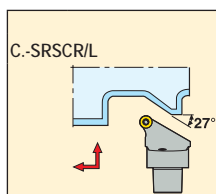
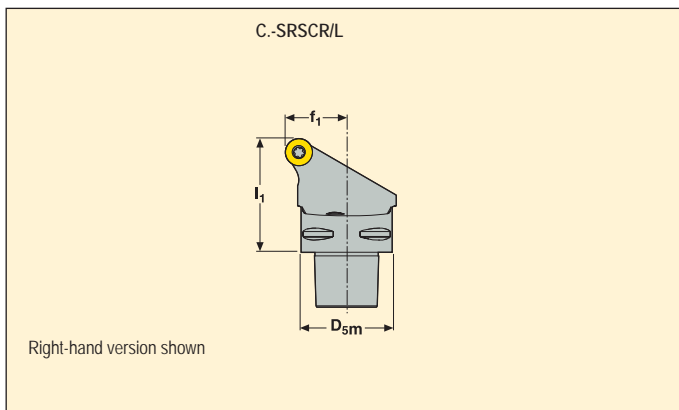

Capto size	Part No.	Dimensions in mm			γ_0°	λ_s°	KG	RCMT	
		D _{5m}	f ₁	l ₁					
C5	06	C5-SRSCR -35060-06	50	35,0	60	0	0	0,7	RCMT0602..
		C5-SRSCCL -35060-06	50	35,0	60	0	0	0,7	RCMT0602..
	08	C5-SRSCR -35060-08	50	35,0	60	0	0	0,7	RCMT0803..
		C5-SRSCCL -35060-08	50	35,0	60	0	0	0,7	RCMT0803..
	10	C5-SRSCR -35060-10	50	35,0	60	0	0	0,7	RCMT10T3..
		C5-SRSCCL -35060-10	50	35,0	60	0	0	0,7	RCMT10T3..
	12	C5-SRSCR -35060-12	50	35,0	60	0	0	0,8	RCMT1204..
		C5-SRSCCL -35060-12	50	35,0	60	0	0	0,8	RCMT1204..
16	C5-SRSCR -35060-16	50	35,0	60	0	0	0,8	RCMT1606..	
	C5-SRSCCL -35060-16	50	35,0	60	0	0	0,8	RCMT1606..	
C6	10	C6-SRSCR -45065-10	63	45,0	65	0	0	1,2	RCMT10T3..
		C6-SRSCCL -45065-10	63	45,0	65	0	0	1,2	RCMT10T3..
	12	C6-SRSCR -45065-12	63	45,0	65	0	0	1,2	RCMT1204..
		C6-SRSCCL -45065-12	63	45,0	65	0	0	1,2	RCMT1204..
	16	C6-SRSCR -45065-16	63	45,0	65	0	0	1,2	RCMT1606..
		C6-SRSCCL -45065-16	63	45,0	65	0	0	1,2	RCMT1606..

Spare Parts, Parts included in delivery

For size	Insert key	Insert screw	Insert shim	Shim screw	Shim key
-06	T07P-2	C02506-T07P	-	-	-
-08	T09P-2	C03007-T09P	-	-	-
-10	T15P-2	C03510-T15P	111.19-620	CA3507	9/64SMS875
-12	T15P-2	C03512-T15P	111.19-621	CA3507	9/64SMS875
-16	T20P-7	C05013-T20P	SRN160400	CA5010	5SMS795

Accessories, to be ordered separately

Please check availability in current price and stock-list

Toolholders for PCBN inserts RNGN and RNMN



- For insert programme, see page(s) 409-411, 434, 437
- γ_o° = Rake angle, λ_s° = Inclination angle
- For holder code key, see page(s) 10-11

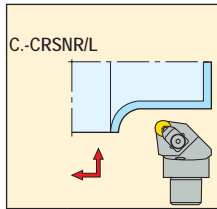
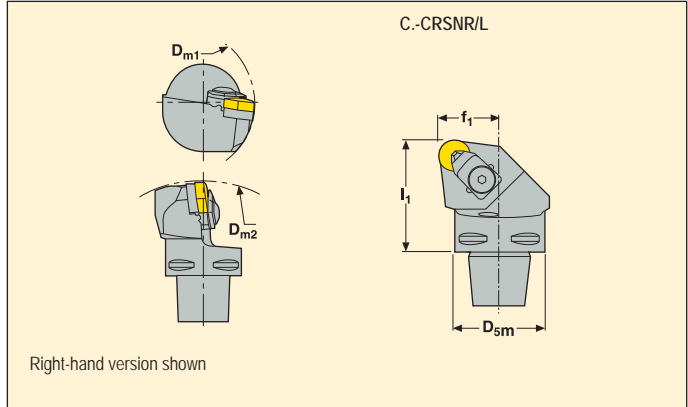

Capto size	Part No.	Dimensions in mm					γ_o°	λ_s°	KG		
		D _{5m}	f ₁	l ₁	D _{m1}	D _{m2}					
C4	C4-CRSNR -27050-09	40	27,0	50	75	165	0	-8	0,5	RN.N0903..	
	C4-CRSNL -27050-09	40	27,0	50	75	165	0	-8	0,5	RN.N0903..	
	C4-CRSNR -27050-12	40	27,0	50	75	165	0	-8	0,5	RN.N1203..	
	C4-CRSNL -27050-12	40	27,0	50	75	165	0	-8	0,5	RN.N1203..	
C5	C5-CRSNR -35060-09	50	35,0	60	95	165	0	-8	0,8	RN.N0903..	
	C5-CRSNL -35060-09	50	35,0	60	95	165	0	-8	0,8	RN.N0903..	
	C5-CRSNR -35060-12	50	35,0	60	95	165	0	-8	0,8	RN.N1203..	
	C5-CRSNL -35060-12	50	35,0	60	95	165	0	-8	0,8	RN.N1203..	
C6	C6-CRSNR -45065-09	63	45,0	65	121	165	0	-8	1,3	RN.N0903..	
	C6-CRSNL -45065-09	63	45,0	65	121	165	0	-8	1,3	RN.N0903..	
	C6-CRSNR -45065-12	63	45,0	65	121	165	0	-8	1,3	RN.N1203..	
	C6-CRSNL -45065-12	63	45,0	65	121	165	0	-8	1,3	RN.N1203..	

Spare Parts, Parts included in delivery

For size	Cantilever clamp	Clamp key	Insert shim	Pressure plate	Shim screw	Shim key
-09	CC17P-09	4SMS795	117.10-620	P1311-09	174.10-652-T07P	T07P-2
-12	CC17P	4SMS795	117.10-622	P1311	F94009-T09P	T09P-2

Accessories*

Please check availability in current price and stock-list

*To be ordered separately
**Shim 117.10-621 for insert RN.N1204.., to be ordered separately

Toolholders for inserts RNMA and RNMG



- For insert programme, see page(s) 371
- γ_0° = Rake angle, λ_s° = Inclination angle
- For holder code key, see page(s) 10-11

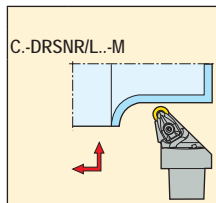
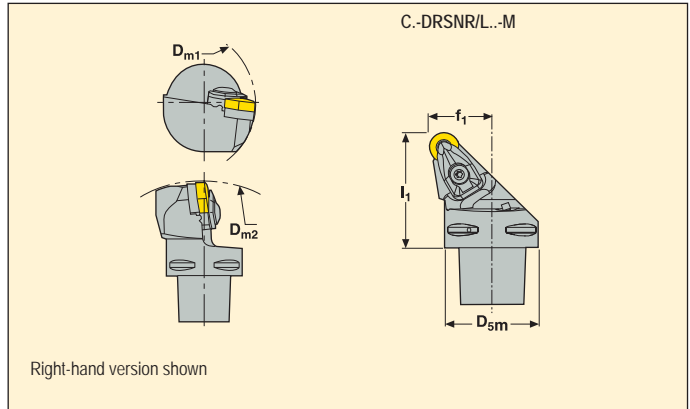

Capto size	Part No.	Dimensions in mm					γ_0°	λ_s°	KG	
		D _{sm}	f ₁	l ₁	D _{m1}	D _{m2}				
C4	C4-DRSNR -27050-12-M	40	27,0	50	110	140	-6	-6	0,4	RN..1204..
	C4-DRSNL -27050-12-M	40	27,0	50	110	140	-6	-6	0,4	RN..1204..
C5	C5-DRSNR -35060-12-M	50	35,0	60	110	165	-6	-6	0,7	RN..1204..
	C5-DRSNL -35060-12-M	50	35,0	60	110	165	-6	-6	0,7	RN..1204..
	C5-DRSNR -35060-19-M	50	35,0	60	95	165	-6	-6	0,8	RN..1906..
	C5-DRSNL -35060-19-M	50	35,0	60	95	165	-6	-6	0,8	RN..1906..
C6	C6-DRSNR -45065-12-M	63	45,0	65	110	190	-6	-6	0,9	RN..1204..
	C6-DRSNL -45065-12-M	63	45,0	65	110	190	-6	-6	0,9	RN..1204..
	C6-DRSNR -45065-19-M	63	45,0	65	121	165	-6	-6	1,3	RN..1906..
	C6-DRSNL -45065-19-M	63	45,0	65	121	165	-6	-6	1,3	RN..1906..

Spare Parts, Parts included in delivery

Accessories*

For size	Clamp pin	Clamp screw	Floating wedge clamp	Insert shim	Shim/clamp key	Shim screw	Spring	Clamp kit
-12	FP2012	L85021-T15P	CD12-S	DRN120600	T15P-2	C04008-T15P	S6912	CD12-S12
-19	FP2012	L86026-T20P	CD19-S	DRN190600	T20P-7L	C05010-T20P	S7010	CD19-S19

Please check availability in current price and stock-list

*To be ordered separately

Toolholders for inserts SNGA, SNMA, SNMG and SNMM



- For insert programme, see page(s) 374-378, 413
- γ_0° = Rake angle, λ_s° = Inclination angle
- For holder code key, see page(s) 10-11

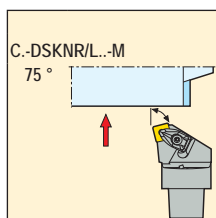
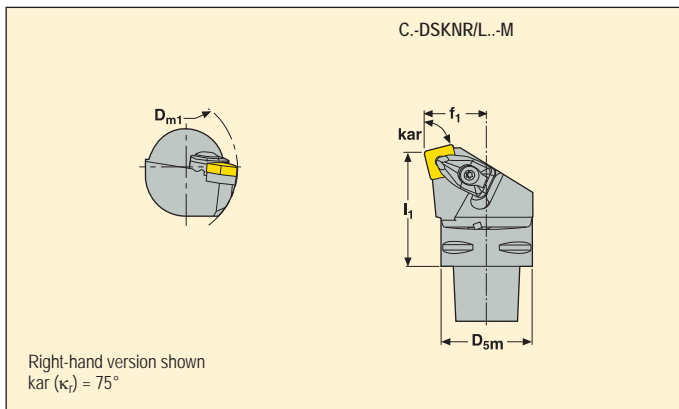

Capto size	Part No.	Dimensions in mm				γ_0°	λ_s°	KG	Key
		D _{5m}	f ₁	l ₁	D _{m1}				
C4	C4-DSKNR -27050-09-M	40	27,0	50	75	-6	-6	0,5	SN..0903..
	C4-DSKNL -27050-09-M	40	27,0	50	75	-6	-6	0,5	SN..0903..
	C4-DSKNR -27050-12-M	40	27,0	50	110	-6	-6	0,5	SN..1204..
	C4-DSKNL -27050-12-M	40	27,0	50	110	-6	-6	0,5	SN..1204..
15	C4-DSKNR -27050-15-M	40	27,0	50	75	-6	-6	0,5	SN..1506..
	C4-DSKNL -27050-15-M	40	27,0	50	75	-6	-6	0,5	SN..1506..
C5	C5-DSKNR -35060-12-M	50	35,0	60	110	-6	-6	0,8	SN..1204..
	C5-DSKNL -35060-12-M	50	35,0	60	110	-6	-6	0,8	SN..1204..
	C5-DSKNR -35060-15-M	50	35,0	60	125	-6	-6	0,9	SN..1506..
	C5-DSKNL -35060-15-M	50	35,0	60	125	-6	-6	0,9	SN..1506..
	C5-DSKNR -35060-19-M	50	35,0	60	125	-6	-6	0,9	SN..1906..
	C5-DSKNL -35060-19-M	50	35,0	60	125	-6	-6	0,9	SN..1906..

Spare Parts, Parts included in delivery

Accessories*

For size	Clamp pin	Clamp screw	Floating wedge clamp	Insert shim	Shim/clamp key	Shim screw	Spring	Clamp kit
-09	FP1508	L84017-T09P	CD09-S	DSN090310	T09P-2	C03007-T09P	S5608	CD09-S09
-12	FP2012	L85021-T15P	CD12-S	DSN120616	T15P-2	C04008-T15P	S6912	CD12-S12
-15	FP2012	L86026-T20P	CD16-S	DSN150624	T20P-7L	C05010-T20P	S7010	CD16-S16
-19	FP2012	L86026-T20P	CD19-S	DSN190624	T20P-7L	C05010-T20P	S7010	CD19-S19

Please check availability in current price and stock-list

*To be ordered separately
 Shim DSN120416 for insert SN..1206.., to be ordered separately
 Shim DSN190640 for insert SN..190624.., to be ordered separately

Toolholders for inserts SNGA, SNMA, SNMG and SNMM



- For insert programme, see page(s) 374-378, 413
- γ_0° = Rake angle, λ_s° = Inclination angle
- For holder code key, see page(s) 10-11

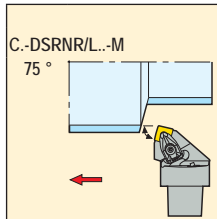
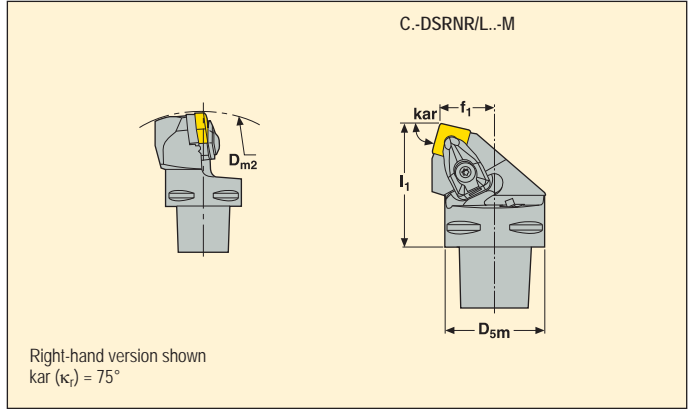

Capto size	Part No.	Dimensions in mm				γ_0°	λ_s°	KG	Key
		D _{sm}	f ₁	I ₁	D _{m2}				
C4	C4-DSRNR -22050-09-M	40	22,0	50	165	-6	-6	0,5	SN..0903..
	C4-DSRNL -22050-09-M	40	22,0	50	165	-6	-6	0,5	SN..0903..
	C4-DSRNR -22050-12-M	40	22,0	50	140	-6	-6	0,4	SN..1204..
	C4-DSRNL -22050-12-M	40	22,0	50	140	-6	-6	0,4	SN..1204..
C5	C4-DSRNR -22055-15-M	40	22,0	55	165	-6	-6	0,5	SN..1506..
	C4-DSRNL -22055-15-M	40	22,0	55	165	-6	-6	0,5	SN..1506..
	C5-DSRNR -27060-12-M	50	27,0	60	165	-6	-6	0,7	SN..1204..
	C5-DSRNL -27060-12-M	50	27,0	60	165	-6	-6	0,7	SN..1204..
C5	C5-DSRNR -27060-15-M	50	27,0	60	165	-6	-6	0,9	SN..1506..
	C5-DSRNL -27060-15-M	50	27,0	60	165	-6	-6	0,9	SN..1506..
	C5-DSRNR -27060-19-M	50	27,0	60	165	-6	-6	0,9	SN..1906..
	C5-DSRNL -27060-19-M	50	27,0	60	165	-6	-6	0,9	SN..1906..

Spare Parts, Parts included in delivery

For size	Clamp pin	Clamp screw	Floating wedge clamp	Insert shim	Shim/clamp key	Shim screw	Spring	Clamp kit
-09	FP1508	L84017-T09P	CD09-S	DSN090310	T09P-2	C03007-T09P	S5608	CD09-S09
-12	FP2012	L85021-T15P	CD12-S	DSN120616	T15P-2	C04008-T15P	S6912	CD12-S12
-15	FP2012	L86026-T20P	CD16-S	DSN150624	T20P-7L	C05010-T20P	S7010	CD16-S16
-19	FP2012	L86026-T20P	CD19-S	DSN190624	T20P-7L	C05010-T20P	S7010	CD19-S19

Accessories*

Please check availability in current price and stock-list

*To be ordered separately
Shim DSN120416 for insert SN..1206.., to be ordered separately

Toolholders for inserts SNGA, SNMA, SNMG and SNMM



- For insert programme, see page(s) 374-378
- γ_0° = Rake angle, λ_s° = Inclination angle
- For holder code key, see page(s) 10-11

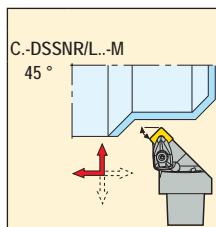
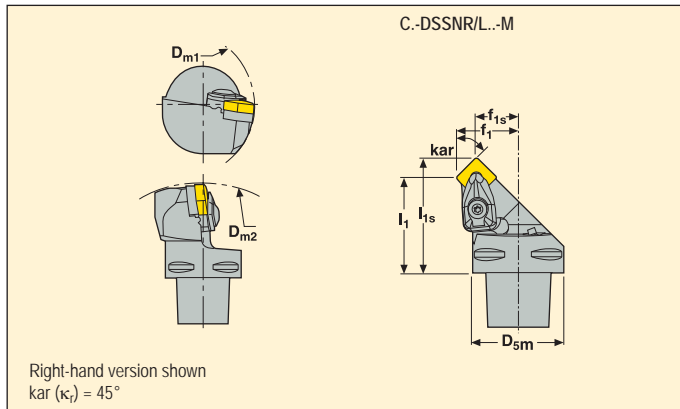

Capto size	Part No.	Dimensions in mm								γ_0°	λ_s°	KG	Key
		D _{5m}	f ₁	f _{1s}	l ₁	l _{1s}	D _{m1}	D _{m2}					
C4	C4-DSSNR -27044-09-M	40	27,0	20,9	44	50,0	75	165	-8	0	0,4	SN..0903..	
	C4-DSSNL -27044-09-M	40	27,0	20,9	44	50,0	75	165	-8	0	0,4	SN..0903..	
	C4-DSSNR -27042-12-M	40	27,0	18,7	42	50,3	110	140	-8	0	0,4	SN..1203..	
	C4-DSSNL -27042-12-M	40	27,0	18,7	42	50,3	110	140	-8	0	0,4	SN..1203..	
	C4-DSSNR -27045-15-M	40	27,0	16,8	45	55,2	125	145	-8	0	0,5	SN..1506..	
	C4-DSSNL -27045-15-M	40	27,0	16,8	45	55,2	125	145	-8	0	0,5	SN..1506..	
C5	C5-DSSNR -35052-12-M	50	35,0	26,7	52	60,3	110	165	-8	0	0,7	SN..1203..	
	C5-DSSNL -35052-12-M	50	35,0	26,7	52	60,3	110	165	-8	0	0,7	SN..1203..	
	C5-DSSNR -35050-15-M	50	35,0	24,8	50	60,2	125	165	-8	0	0,6	SN..1506..	
	C5-DSSNL -35050-15-M	50	35,0	24,8	50	60,2	125	165	-8	0	0,6	SN..1506..	
	C5-DSSNR -35048-19-M	50	35,0	22,5	48	60,5	125	165	-8	0	0,9	SN..1906..	
	C5-DSSNL -35048-19-M	50	35,0	22,5	48	60,5	125	165	-8	0	0,9	SN..1906..	

Spare Parts, Parts included in delivery

For size	Clamp pin	Clamp screw	Floating wedge clamp	Insert shim	Shim/clamp key	Shim screw	Spring	Clamp kit
-09	FP1508	L84017-T09P	CD09-S	DSN090310	T09P-2	C03007-T09P	S5608	CD09-S09
-12	FP2012	L85021-T15P	CD12-S	DSN120616	T15P-2	C04008-T15P	S6912	CD12-S12
-15	FP2012	L86026-T20P	CD16-S	DSN150624	T20P-7L	C05010-T20P	S7010	CD16-S16
-19	FP2012	L86026-T20P	CD19-S	DSN190624	T20P-7L	C05010-T20P	S7010	CD19-S19

Accessories*

Please check availability in current price and stock-list

*To be ordered separately
Shim DSN120416 for insert SN..1206.., to be ordered separately

Toolholders for inserts SNGA, SNMA, SNMG and SNMM



- For insert programme, see page(s) 374-378
- γ_0° = Rake angle, λ_s° = Inclination angle
- For holder code key, see page(s) 10-11

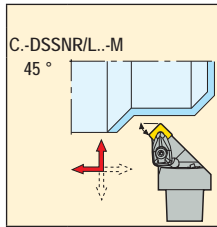
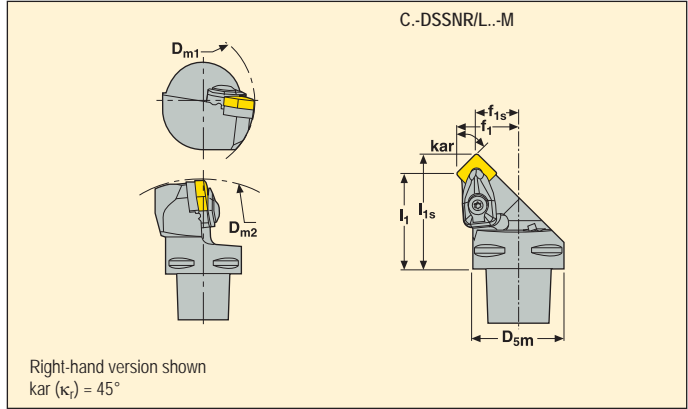

Capto size	Part No.	Dimensions in mm								γ_0°	λ_s°	KG	Capto size
		D _{5m}	f ₁	f _{1s}	l ₁	l _{1s}	D _{m1}	D _{m2}					
C6	C6-DSSNR -45056-12-M	63	45,0	36,7	56	64,3	110	190	-8	0	1,1	SN..1203..	
	C6-DSSNL -45056-12-M	63	45,0	36,7	56	64,3	110	190	-8	0	1,1	SN..1203..	
15	C6-DSSNR -45054-15-M	63	45,0	34,8	54	64,2	125	190	-8	0	1,1	SN..1506..	
	C6-DSSNL -45054-15-M	63	45,0	34,8	54	64,2	125	190	-8	0	1,1	SN..1506..	
19	C6-DSSNR -45052-19-M	63	45,0	32,5	52	64,5	125	190	-8	0	1,1	SN..1906..	
	C6-DSSNL -45052-19-M	63	45,0	32,5	52	64,5	125	190	-8	0	1,1	SN..1906..	

Spare Parts, Parts included in delivery

Accessories*

For size	Clamp pin	Clamp screw	Floating wedge clamp	Insert shim	Shim/clamp key	Shim screw	Spring	Clamp kit
-12	FP2012	L85021-T15P	CD12-S	DSN120616	T15P-2	C04008-T15P	S6912	CD12-S12
-15	FP2012	L86026-T20P	CD16-S	DSN150624	T20P-7L	C05010-T20P	S7010	CD16-S16
-19	FP2012	L86026-T20P	CD19-S	DSN190624	T20P-7L	C05010-T20P	S7010	CD19-S19

Please check availability in current price and stock-list

*To be ordered separately
Shim DSN120416 for insert SN..1206.., to be ordered separately

Toolholders for inserts SNGA, SNMA, SNMG and SNMM



- For insert programme, see page(s) 374-378, 413
- γ_0° = Rake angle, λ_s° = Inclination angle
- For holder code key, see page(s) 10-11

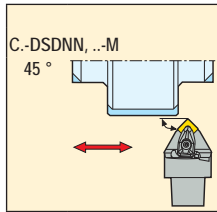
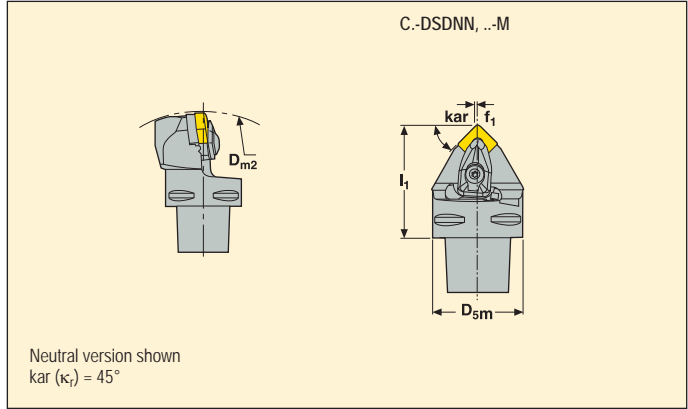

Capto size	Part No.	Dimensions in mm				γ_0°	λ_s°	KG	Key
		D _{sm}	f ₁	I ₁	D _{m2}				
C4	09 C4-DSDNN -00050-09-M	40	0,3	50	165	-6	-6	0,4	SN..0903..
	12 C4-DSDNN -00050-12-M	40	0,3	50	140	-6	-6	0,5	SN..1204..
	15 C4-DSDNN -00055-15-M	40	0,5	55	165	-6	-6	0,5	SN..1506..
C5	12 C5-DSDNN -00060-12-M	50	0,3	60	165	-6	-6	0,7	SN..1204..
	15 C5-DSDNN -00060-15-M	50	0,5	60	165	-6	-6	0,7	SN..1506..
	19 C5-DSDNN -00065-19-M	50	0,5	65	170	-6	-6	0,9	SN..1906..
C6	12 C6-DSDNN -00065-12-M	63	0,3	65	190	-6	-6	1,5	SN..1204..
	15 C6-DSDNN -00065-15-M	63	0,5	65	190	-6	-6	1,2	SN..1506..
	19 C6-DSDNN -00070-19-M	63	0,5	70	195	-6	-6	1,2	SN..1906..
C8	25 C8-DSDNN -00080-25	80	0,5	80	250	-5	-9	2,3	SN..2507..

Spare Parts, Parts included in delivery

For size	Clamp pin	Clamp screw	Floating wedge clamp	Insert shim	Shim/clamp key	Shim screw	Spring	Clamp kit
-09	FP1508	L84017-T09P	CD09-S	DSN090310	T09P-2	C03007-T09P	S5608	CD09-S09
-12	FP2012	L85021-T15P	CD12-S	DSN120616	T15P-2	C04008-T15P	S6912	CD12-S12
-15	FP2012	L86026-T20P	CD16-S	DSN150624	T20P-7L	C05010-T20P	S7010	CD16-S16
-19	FP2012	L86026-T20P	CD19-S	DSN190624	T20P-7L	C05010-T20P	S7010	CD19-S19
-25	-	-	-	DSN250624	T25P-7	C06012-T25P	-	CD25-S25

Accessories*

Please check availability in current price and stock-list
Shim DSN120416 for insert SN..1206.., to be ordered separately

*To be ordered separately
Shim DSN190640 for insert SN..190624.., to be ordered separately
Shim DSN250424 for insert SN..2509.., to be ordered separately

Toolholders for PCBN inserts SNGN, SNMN and SNUN



- For insert programme, see page(s) 414-415, 417
- γ_0° = Rake angle, λ_s° = Inclination angle
- For holder code key, see page(s) 10-11

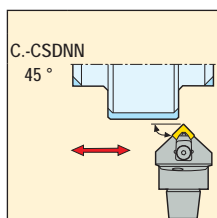
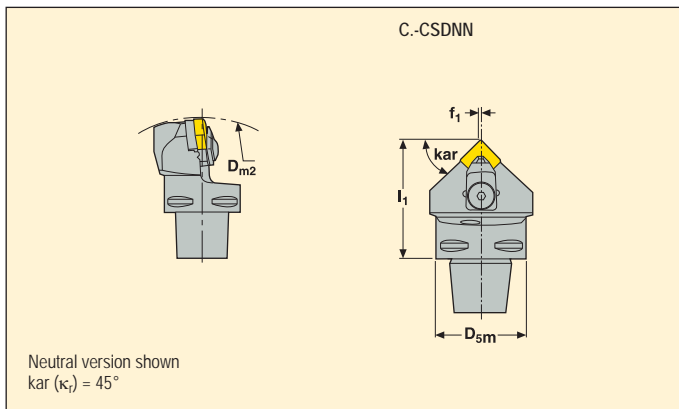

Capto size	Part No.	Dimensions in mm				γ_0°	λ_s°	KG	Color
		D _{sm}	f ₁	I ₁	D _{m2}				
C4	09 C4-CSDNN -00050-09	40	0,3	50	165	-6	-6	0,4	SN.N0903..
	12 C4-CSDNN -00050-12	40	0,3	50	165	-6	-6	0,4	SN.N1204..
C5	09 C5-CSDNN -00060-09	50	0,3	60	165	-6	-6	0,7	SN.N0903..
	12 C5-CSDNN -00060-12	50	0,3	60	165	-6	-6	0,7	SN.N1204..
C6	12 C6-CSDNN -00065-12	63	0,3	65	165	-6	-6	1,2	SN.N1204..

Spare Parts, Parts included in delivery

Accessories*

For size	Cantilever clamp	Clamp key	Insert shim	Pressure plate	Shim screw	Shim key
-09	CC17P-09	4SMS795	CSN090412	P1311-09	174.10-652-T07P	T07P-2
-12	CC20P	4SMS795	174.10-621	P1311	F94009-T09P	T09P-2

Please check availability in current price and stock-list

*To be ordered separately
Shim 174.10-622 for insert SN.N1203.., to be ordered separately

Toolholders for PCBN inserts SNGN, SNMN and SNUN



- For insert programme, see page(s) 414-415, 417
- γ_0° = Rake angle, λ_s° = Inclination angle
- For holder code key, see page(s) 10-11

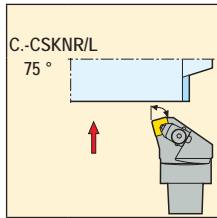
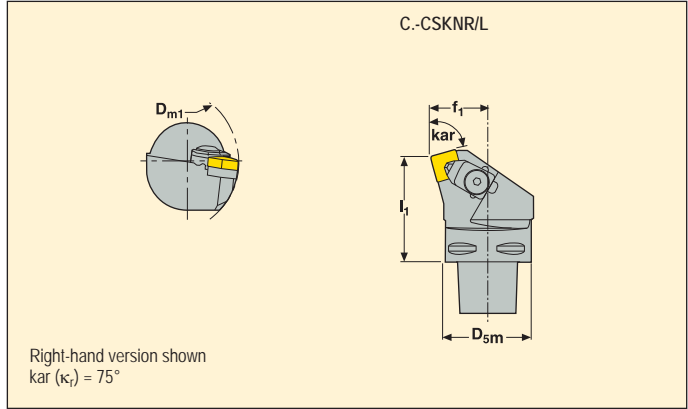

Capto size	Part No.	Dimensions in mm				γ_0°	λ_s°	KG	Key
		D _{5m}	f ₁	l ₁	D _{m1}				
C4	C4-CSKNR -27050-09	40	27,0	50	75	-6	-6	0,5	SN.N0903..
	C4-CSKNL -27050-09	40	27,0	50	75	-6	-6	0,5	SN.N0903..
	C4-CSKNR -27050-12	40	27,0	50	75	-6	-6	0,5	SN.N1204..
	C4-CSKNL -27050-12	40	27,0	50	75	-6	-6	0,5	SN.N1204..
C5	C5-CSKNR -35060-09	50	35,0	60	95	-6	-6	0,8	SN.N0903..
	C5-CSKNL -35060-09	50	35,0	60	95	-6	-6	0,8	SN.N0903..
	C5-CSKNR -35060-12	50	35,0	60	95	-6	-6	0,9	SN.N1204..
	C5-CSKNL -35060-12	50	35,0	60	95	-6	-6	0,9	SN.N1204..
C6	C6-CSKNR -45065-12	63	45,0	65	121	-6	-6	1,5	SN.N1204..
	C6-CSKNL -45065-12	63	45,0	65	121	-6	-6	1,5	SN.N1204..

Spare Parts, Parts included in delivery

For size	Cantilever clamp	Clamp key	Insert shim	Pressure plate	Shim screw	Shim key
-09	CC17P-09	4SMS795	CSN090412	P1311-09	174.10-652-T07P	T07P-2
-12	CC20P	4SMS795	174.10-621	P1311	F94009-T09P	T09P-2

Accessories*

Please check availability in current price and stock-list

*To be ordered separately
Shim 174.10-622 for insert SN.N1203.., to be ordered separately

Toolholders for PCBN inserts SNGN, SNMN and SNUN



- For insert programme, see page(s) 414-415, 417
- γ_0° = Rake angle, λ_s° = Inclination angle
- For holder code key, see page(s) 10-11

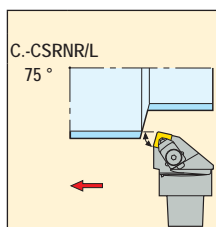
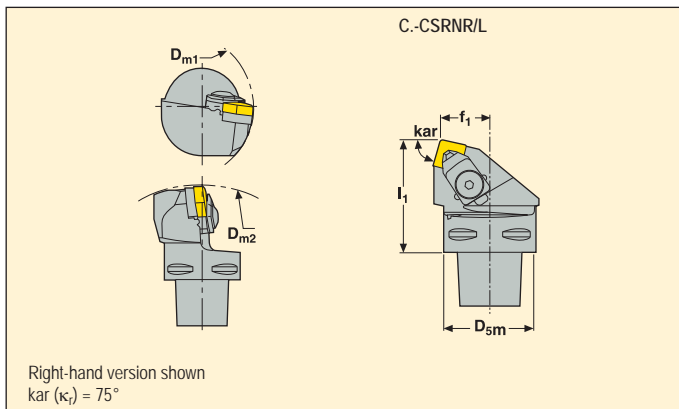

Capto size	Part No.	Dimensions in mm					γ_0°	λ_s°	KG	Color	
		D _{sm}	f ₁	I ₁	D _{m1}	D _{m2}					
C4	09	C4-CSRNR -22050-09	40	22,0	50	75	165	-6	-6	0,4	SN.N0903..
		C4-CSRNL -22050-09	40	22,0	50	75	165	-6	-6	0,4	SN.N0903..
	12	C4-CSRNR -22050-12	40	22,0	50	75	165	-6	-6	0,5	SN.N1204..
		C4-CSRNL -22050-12	40	22,0	50	75	165	-6	-6	0,5	SN.N1204..
C5	09	C5-CSRNR -27060-09	50	27,0	60	95	165	-6	-6	0,8	SN.N0903..
		C5-CSRNL -27060-09	50	27,0	60	95	165	-6	-6	0,8	SN.N0903..
	12	C5-CSRNR -27060-12	50	27,0	60	95	165	-6	-6	0,8	SN.N1204..
		C5-CSRNL -27060-12	50	27,0	60	95	165	-6	-6	0,8	SN.N1204..
C6	12	C6-CSRNR -35065-12	63	35,0	65	121	165	-6	-6	1,4	SN.N1204..
		C6-CSRNL -35065-12	63	35,0	65	121	165	-6	-6	1,4	SN.N1204..

Spare Parts, Parts included in delivery

Accessories*

For size	Cantilever clamp	Clamp key	Insert shim	Pressure plate	Shim screw	Shim key
-09	CC17P-09	4SMS795	CSN090412	P1311-09	174.10-652-T07P	T07P-2
-12	CC20P	4SMS795	174.10-621	P1311	F94009-T09P	T09P-2

Please check availability in current price and stock-list

*To be ordered separately
Shim 174.10-622 for insert SN.N1203.., to be ordered separately

Toolholders for inserts TCGT, TCMT and TCMW



- For insert programme, see page(s) 380-383, 434
- γ_0° = Rake angle, λ_s° = Inclination angle
- For holder code key, see page(s) 10-11

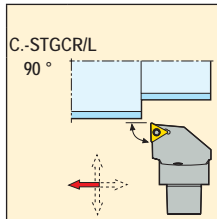
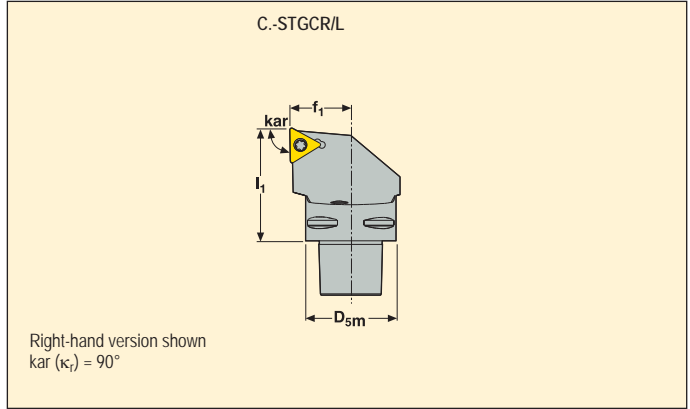

Capto size	Part No.	Dimensions in mm			γ_0°	λ_s°	KG	Key
		D _{5m}	f ₁	l ₁				
C4	C4-STGCR -27050-16	40	27,0	50	0	0	0,5	TC..16T3..
	C4-STGCL -27050-16	40	27,0	50	0	0	0,5	TC..16T3..
C5	C5-STGCR -35060-16	50	35,0	60	0	0	0,9	TC..16T3..
	C5-STGCL -35060-16	50	35,0	60	0	0	0,9	TC..16T3..
C6	C6-STGCR -45065-16	63	45,0	65	0	0	1,2	TC..16T3..
	C6-STGCL -45065-16	63	45,0	65	0	0	1,2	TC..16T3..

Spare Parts, Parts included in delivery

For size	Insert key	Insert screw	Insert shim	Shim screw	Shim key
-16	T15P-2	C03509-T15P	STN160312	CA3510	9/64SMS875

Accessories, to be ordered separately

Please check availability in current price and stock-list

Toolholders for inserts TCGT, TCMT, TCMW and TCMX



- For insert programme, see page(s) 381-383, 434
- γ_0° = Rake angle, λ_s° = Inclination angle
- For holder code key, see page(s) 10-11

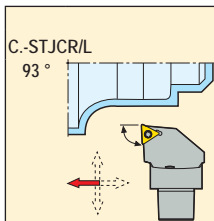
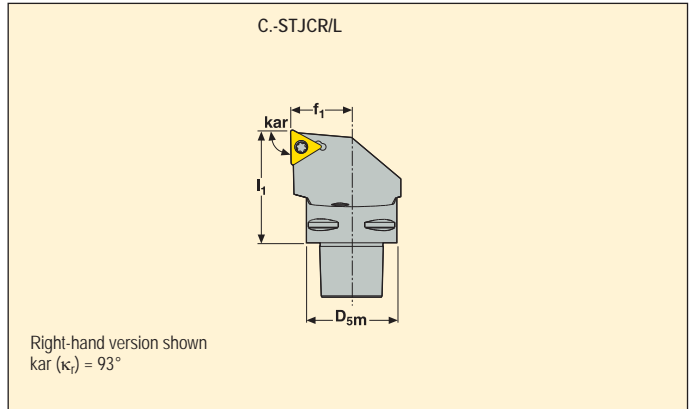

Capto size	Part No.	Dimensions in mm			γ_0°	λ_s°	KG	Warning symbol
		D _{5m}	f ₁	I ₁				
C4	C4-STJCR -27050-16	40	27,0	50	0	0	0,5	TC..16T3..
	C4-STJCL -27050-16	40	27,0	50	0	0	0,5	TC..16T3..
C5	C5-STJCR -35060-16	50	35,0	60	0	0	0,9	TC..16T3..
	C5-STJCL -35060-16	50	35,0	60	0	0	0,9	TC..16T3..

Spare Parts, Parts included in delivery

For size	Insert key	Insert screw	Insert shim	Shim screw
-16	T15P-2	C03509-T15P	STN160312	CA3510

Accessories, to be ordered separately

Shim key
9/64SMS875

Please check availability in current price and stock-list

Toolholders for inserts TNGA, TNMA, TNMG, TNMM and TNMX



- For insert programme, see page(s) 385-390, 420
- γ_0° = Rake angle, λ_s° = Inclination angle
- For holder code key, see page(s) 10-11

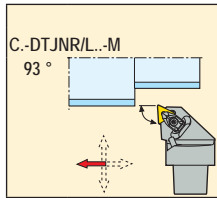
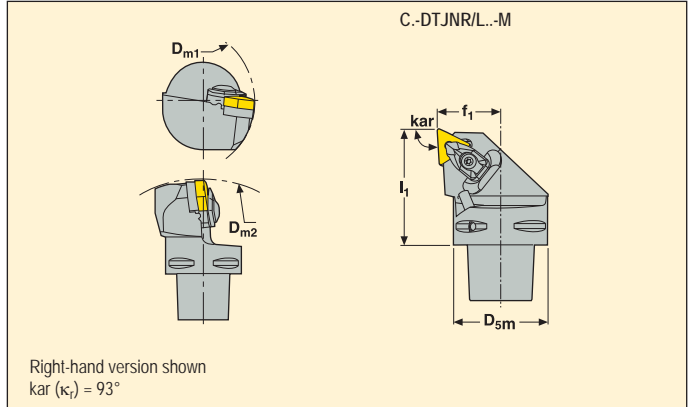

Capto size	Part No.	Dimensions in mm						γ_0°	λ_s°	KG	Warning
		D _{5m}	f ₁	l ₁	D _{m1}	D _{m2}					
C4	C4-DTJNR -27050-16-M	40	27,0	50	110	140	-6	-6	0,4	TN..1604..	
	C4-DTJNL -27050-16-M	40	27,0	50	110	140	-6	-6	0,4	TN..1604..	
	C4-DTJNR -27050-22-M	40	27,0	50	110	140	-6	-6	0,5	TN..2204..	
	C4-DTJNL -27050-22-M	40	27,0	50	110	140	-6	-6	0,5	TN..2204..	
C5	C5-DTJNR -35060-16-M	50	35,0	60	110	165	-6	-6	0,8	TN..1604..	
	C5-DTJNL -35060-16-M	50	35,0	60	110	165	-6	-6	0,8	TN..1604..	
	C5-DTJNR -35060-22-M	50	35,0	60	110	165	-6	-6	0,8	TN..2204..	
	C5-DTJNL -35060-22-M	50	35,0	60	110	165	-6	-6	0,8	TN..2204..	
C6	C6-DTJNR -45065-16-M	63	45,0	65	110	190	-6	-6	1,3	TN..1604..	
	C6-DTJNL -45065-16-M	63	45,0	65	110	190	-6	-6	1,3	TN..1604..	
	C6-DTJNR -45065-22-M	63	45,0	65	110	190	-6	-6	1,3	TN..2204..	
	C6-DTJNL -45065-22-M	63	45,0	65	110	190	-6	-6	1,3	TN..2204..	

Spare Parts, Parts included in delivery

Accessories*

For size	Clamp pin	Clamp screw	Floating wedge clamp	Insert shim	Shim/clamp key	Shim screw	Spring	Clamp kit
-16	FP1508	L84017-T09P	CD09-S	DTN160616	T09P-2	C03007-T09P	S5608	CD09-S09
-22	FP2012	L85021-T15P	CD12-S	DTN220616	T15P-2	C04008-T15P	S6912	CD12-S12

Please check availability in current price and stock-list

*To be ordered separately
Shim DTN220640 for insert TN..220432.., to be ordered separately

Toolholders for inserts TNGA, TNMA, TNMG and TNMM



- For insert programme, see page(s) 385-390, 420
- γ_0° = Rake angle, λ_s° = Inclination angle
- For holder code key, see page(s) 10-11

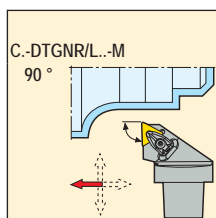
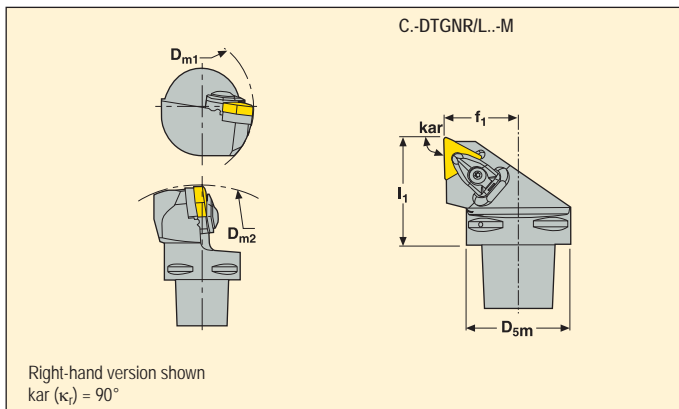

Capto size	Part No.	Dimensions in mm					γ_0°	λ_s°	KG	Warning symbol
		D _{sm}	f ₁	I ₁	D _{m1}	D _{m2}				
C4	C4-DTGNR -27050-22-M	40	27,0	50	110	140	-6	-6	0,5	TN..2204..
	C4-DTGNL -27050-22-M	40	27,0	50	110	140	-6	-6	0,5	TN..2204..
C5	C5-DTGNR -35060-22-M	50	35,0	60	110	165	-6	-6	0,8	TN..2204..
	C5-DTGNL -35060-22-M	50	35,0	60	110	165	-6	-6	0,8	TN..2204..
C6	C6-DTGNR -45065-16-M	63	45,0	65	110	190	-6	-6	1,3	TN..1604..
	C6-DGTL -45065-16-M	63	45,0	65	110	190	-6	-6	1,3	TN..1604..
	C6-DTGNR -45065-27-M	63	45,0	65	121	165	-6	-6	1,3	TN..2706..
	C6-DTGNL -45065-27-M	63	45,0	65	121	165	-6	-6	1,3	TN..2706..

Spare Parts, Parts included in delivery

Accessories*

For size	Clamp pin	Clamp screw	Floating wedge clamp	Insert shim	Shim/clamp key	Shim screw	Spring	Clamp kit
-16	FP1508	L84017-T09P	CD09-S	DTN160616	T09P-2	C03007-T09P	S5608	CD09-S09
-22	FP2012	L85021-T15P	CD12-S	DTN220616	T15P-2	C04008-T15P	S6912	CD12-S12
-27	FP2012	L86026-T20P	CD16-S	DTN270416	T20P-7L	C05010-T20P	S7010	CD16-S16

Please check availability in current price and stock-list

*To be ordered separately
Shim DTN220640 for insert TN..220432... to be ordered separately

Toolholders for inserts TNGA, TNMA, TNMG and TNMM



- For insert programme, see page(s) 385-390, 420
- γ_0° = Rake angle, λ_s° = Inclination angle
- For holder code key, see page(s) 10-11

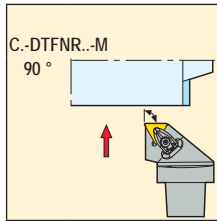
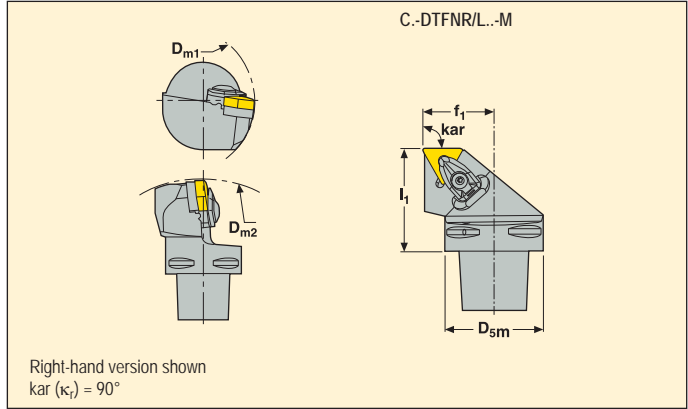

Capto size	Part No.	Dimensions in mm						γ_0°	λ_s°	KG	
		D _{5m}	f ₁	l ₁	D _{m1}	D _{m2}					
C4	C4-DTFNR -27050-16-M	40	27,0	50	110	140	-6	-6	0,4	TN..1604..	
	C4-DTFNL -27050-16-M	40	27,0	50	110	140	-6	-6	0,4	TN..1604..	
	C4-DTFNR -27050-22-M	40	27,0	50	110	140	-6	-6	0,5	TN..2204..	
	C4-DTFNL -27050-22-M	40	27,0	50	110	140	-6	-6	0,5	TN..2204..	
C5	C5-DTFNR -35060-16-M	50	35,0	60	110	165	-6	-6	0,8	TN..1604..	
	C5-DTFNL -35060-16-M	50	35,0	60	110	165	-6	-6	0,8	TN..1604..	
	C5-DTFNR -35060-22-M	50	35,0	60	110	165	-6	-6	0,9	TN..2204..	
	C5-DTFNL -35060-22-M	50	35,0	60	110	165	-6	-6	0,9	TN..2204..	
C6	C6-DTFNR -45065-16-M	63	45,0	65	110	190	-6	-6	1,5	TN..1604..	
	C6-DTFNL -45065-16-M	63	45,0	65	110	190	-6	-6	1,5	TN..1604..	
	C6-DTFNR -45065-22-M	63	45,0	65	110	190	-6	-6	1,3	TN..2204..	
	C6-DTFNL -45065-22-M	63	45,0	65	110	190	-6	-6	1,3	TN..2204..	
	C6-DTFNR -45065-27-M	63	45,0	65	121	165	-6	-6	1,4	TN..2706..	
	C6-DTFNL -45065-27-M	63	45,0	65	121	165	-6	-6	1,4	TN..2706..	

Spare Parts, Parts included in delivery

Accessories*

For size	Clamp pin	Clamp screw	Floating wedge clamp	Insert shim	Shim/clamp key	Shim screw	Spring	Clamp kit
-16	FP1508	L84017-T09P	CD09-S	DTN160616	T09P-2	C03007-T09P	S5608	CD09-S09
-22	FP2012	L85021-T15P	CD12-S	DTN220616	T15P-2	C04008-T15P	S6912	CD12-S12
-27	FP2012	L86026-T20P	CD16-S	DTN270416	T20P-7L	C05010-T20P	S7010	CD16-S16

Please check availability in current price and stock-list

*To be ordered separately

Shim DTN220640 for insert TN..220432.., to be ordered separately

Toolholders for PCBN inserts TNGN, TNGX, TNMN and TNMX



- For insert programme, see page(s) 421-425
- γ_0° = Rake angle, λ_s° = Inclination angle
- For holder code key, see page(s) 10-11

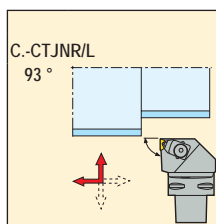
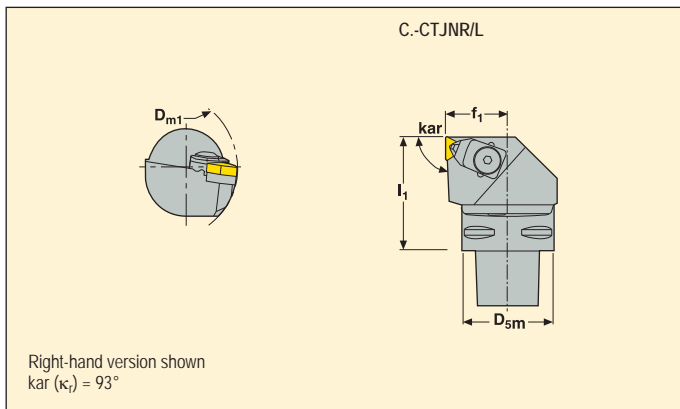

Capto size	Part No.	Dimensions in mm				γ_0°	λ_s°	KG	
		D _{sm}	f ₁	I ₁	D _{m1}				
C4	11 C4-CTJNR -27050-11	40	27,0	50	75	-6	-6	0,5	TN..1103..
	C4-CTJNL -27050-11	40	27,0	50	75	-6	-6	0,5	TN..1103..
C5	11 C5-CTJNR -35060-11	50	35,0	60	95	-6	-6	1,0	TN..1103..
	C5-CTJNL -35060-11	50	35,0	60	95	-6	-6	1,0	TN..1103..
C6	11 C6-CTJNR -45065-11	63	45,0	65	121	-6	-6	1,6	TN..1103..
	C6-CTJNL -45065-11	63	45,0	65	121	-6	-6	1,6	TN..1103..

Spare Parts, Parts included in delivery

Accessories*

For size	Cantilever clamp	Clamp key	Insert shim	Pressure plate	Shim screw	Shim key
-11	CC17P-06	4SMS795	CTN110308	P1311-06	CS2507-T07P	T07P-2

Please check availability in current price and stock-list

*To be ordered separately

Toolholders for inserts VBGT, VBGW, VBMT, VBMW and VCGT



- For insert programme, see page(s) 390-392, 426, 435
- γ_o° = Rake angle, λ_s° = Inclination angle
- For holder code key, see page(s) 10-11

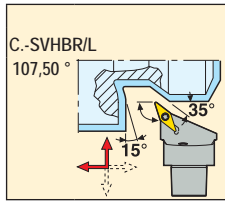
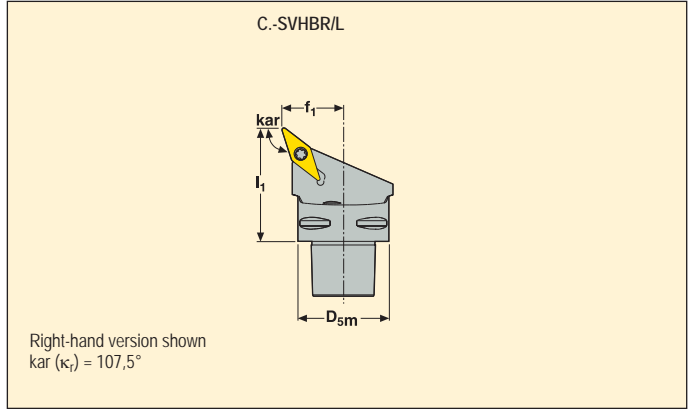

Capto size	Part No.	Dimensions in mm			γ_o°	λ_s°	KG	Insert
		D_{sm}	f_1	l_1				
C3	C3-SVHBR -22040-11	32	22,0	40	0	0	0,2	VB..1102..
	C3-SVHBL -22040-11	32	22,0	40	0	0	0,2	VB..1102..
C4	C4-SVHBR -27050-11	40	27,0	50	0	0	0,4	VB..1102..
	C4-SVHBL -27050-11	40	27,0	50	0	0	0,4	VB..1102..
C4	C4-SVHBR -27050-16	40	27,0	50	0	0	0,4	VB../VC..1604..
	C4-SVHBL -27050-16	40	27,0	50	0	0	0,4	VB../VC..1604..
C5	C5-SVHBR -35060-11	50	35,0	60	0	0	0,7	VB..1102..
	C5-SVHBL -35060-11	50	35,0	60	0	0	0,7	VB..1102..
C5	C5-SVHBR -35060-16	50	35,0	60	0	0	0,7	VB../VC..1604..
	C5-SVHBL -35060-16	50	35,0	60	0	0	0,7	VB../VC..1604..
C6	C6-SVHBR -45065-16	63	45,0	65	0	0	1,2	VB../VC..1604..
	C6-SVHBL -45065-16	63	45,0	65	0	0	1,2	VB../VC..1604..

Spare Parts, Parts included in delivery

For size	Insert key	Insert screw	Insert shim	Shim screw	Shim key
-11	T07P-2	C02506-T07P	-	-	-
-16	T15P-2	C03512-T15P	171.19-620	CA3507	9/64SMS875

Accessories, to be ordered separately

Please check availability in current price and stock-list

Toolholders for inserts VBGT, VBGW, VBMT, VBMM and VCGT



- For insert programme, see page(s) 390-392, 426, 435
- γ_0° = Rake angle, λ_s° = Inclination angle
- For holder code key, see page(s) 10-11

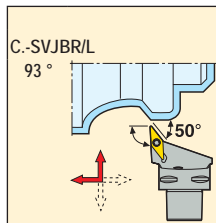
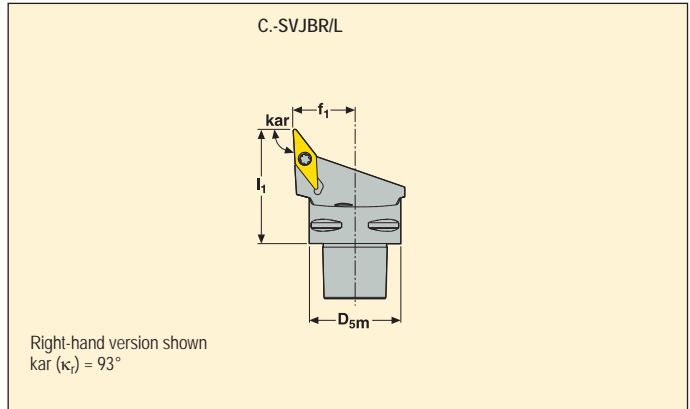

Capto size	Part No.	Dimensions in mm			γ_0°	λ_s°	KG	Key
		D _{5m}	f ₁	I ₁				
C3	C3-SVJBR -22040-11	32	22,0	40	0	0	0,2	VB..1102..
	C3-SVJBL -22040-11	32	22,0	40	0	0	0,2	VB..1102..
C4	C4-SVJBR -27050-11	40	27,0	50	0	0	0,4	VB..1102..
	C4-SVJBL -27050-11	40	27,0	50	0	0	0,4	VB..1102..
	C4-SVJBR -27050-16	40	27,0	50	0	0	0,4	VB../VC..1604..
	C4-SVJBL -27050-16	40	27,0	50	0	0	0,4	VB../VC..1604..
C5	C5-SVJBR -35060-11	50	35,0	60	0	0	0,7	VB..1102..
	C5-SVJBL -35060-11	50	35,0	60	0	0	0,7	VB..1102..
	C5-SVJBR -35060-16	50	35,0	60	0	0	0,7	VB../VC..1604..
	C5-SVJBL -35060-16	50	35,0	60	0	0	0,7	VB../VC..1604..
C6	C6-SVJBR -45065-16	63	45,0	65	0	0	1,1	VB../VC..1604..
	C6-SVJBL -45065-16	63	45,0	65	0	0	1,1	VB../VC..1604..

Spare Parts, Parts included in delivery

For size	Insert key	Insert screw	Insert shim	Shim screw	Shim key
-11	T07P-2	C02506-T07P	-	-	-
-16	T15P-2	C03512-T15P	171.19-620	CA3507	9/64SMS875

Accessories, to be ordered separately

Please check availability in current price and stock-list

Toolholders for inserts VBGT, VBGW, VBMT, VBMT and VCGT



- For insert programme, see page(s) 390-392, 426, 435
- γ_0° = Rake angle, λ_s° = Inclination angle
- For holder code key, see page(s) 10-11

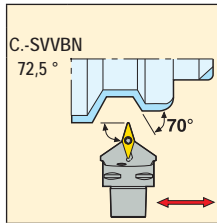
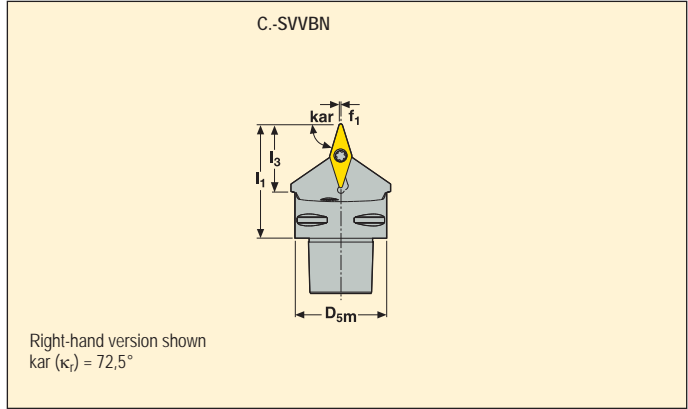

Capto size	Part No.	Dimensions in mm			γ_0°	λ_s°	KG	Insert
		D _{5m}	f ₁	l ₁				
C3	11 C3-SVVBN -00040-11	32	0,3	40	0	0	0,2	VB..1102..
	11 C4-SVVBN -00050-11	40	0,3	50	0	0	0,4	VB..1102..
C4	16 C4-SVVBN -00050-16	40	0,6	50	0	0	0,4	VB../VC..1604..
	16 C5-SVVBN -00060-16	50	0,6	60	0	0	0,7	VB../VC..1604..
C5	16 C6-SVVBN -00065-16	63	0,6	65	0	0	1,1	VB../VC..1604..
C6								

Spare Parts, Parts included in delivery

For size	Insert key	Insert screw	Insert shim	Shim screw	Shim key
-11	T07P-2	C02506-T07P	-	-	-
-16	T15P-2	C03512-T15P	171.19-620	CA3507	9/64SMS875

Accessories, to be ordered separately

Please check availability in current price and stock-list

Toolholders for inserts VNGA, VNGG, VNGM, VNMG and VNMU



- For insert programme, see page(s) 393-394, 427-428
- γ_0° = Rake angle, λ_s° = Inclination angle
- For holder code key, see page(s) 10-11

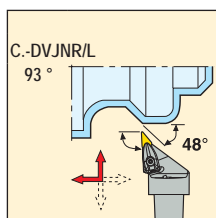
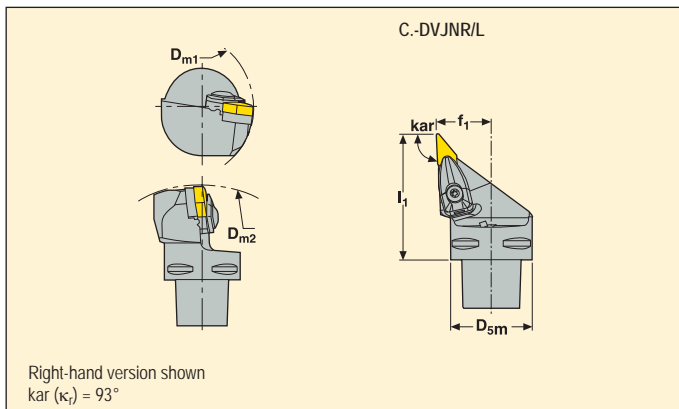

Capto size	Part No.	Dimensions in mm					γ_0°	λ_s°	KG	Key
		D _{5m}	f ₁	I ₁	D _{m1}	D _{m2}				
C4	C4-DVJNR -27055-13	40	27,0	55	60	152	-4	-13	0,5	VN..1304..
	C4-DVJNL -27055-13	40	27,0	55	60	152	-4	-13	0,5	VN..1304..
	C4-DVJNR -27062-16	40	27,0	62	65	152	-4	-13	0,4	VN..1604..
	C4-DVJNL -27062-16	40	27,0	62	65	152	-4	-13	0,4	VN..1604..
C5	C5-DVJNR -35060-13	50	35,0	60	65	170	-4	-13	0,9	VN..1304..
	C5-DVJNL -35060-13	50	35,0	60	65	170	-4	-13	0,9	VN..1304..
	C5-DVJNR -35065-16	50	35,0	65	65	170	-4	-13	0,7	VN..1604..
	C5-DVJNL -35065-16	50	35,0	65	65	170	-4	-13	0,7	VN..1604..
C6	C6-DVJNR -45065-16	63	45,0	65	81	190	-4	-13	1,1	VN..1604..
	C6-DVJNL -45065-16	63	45,0	65	81	190	-4	-13	1,1	VN..1604..

Spare Parts, Parts included in delivery

Accessories*

For size	Clamp pin	Clamp screw	Floating wedge clamp	Insert shim	Shim/clamp key	Shim screw	Spring	Clamp kit
-13	FP1508	L84017-T09P	CD08-S	PVN130308	T09P-2	CS5008-T09P	S5608	CD08-V13
-16	FP2012	L85021-T15P	CD19-S-V16	DVN160310	T15P-2	C03508-T15P	S6912	CD19-V16

Please check availability in current price and stock-list

*To be ordered separately

Toolholders for inserts VNMU



- For insert programme, see page(s) 394
- γ_0° = Rake angle, λ_s° = Inclination angle
- For holder code key, see page(s) 10-11

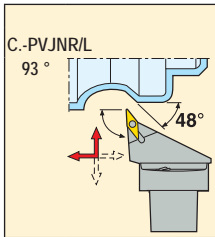
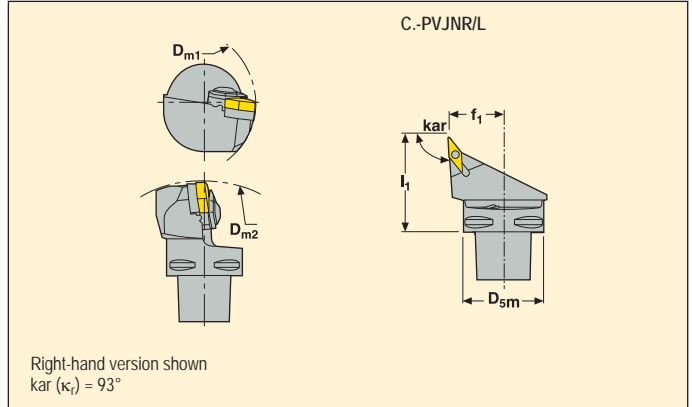

Capto size		Part No.	Dimensions in mm					γ_0°	λ_s°		
			D _{5m}	f ₁	l ₁	D _{m1}	D _{m2}				
C4	13	C4-PVJNR -27050-13	40	27,0	50	75	165	-4,5	-13,5	0,4	VNMU1304..
		C4-PVJNL -27050-13	40	27,0	50	75	165	-4,5	-13,5	0,4	VNMU1304..
C5	13	C5-PVJNR -35060-13	50	35,0	60	95	165	-4,5	-13,5	0,7	VNMU1304..
		C5-PVJNL -35060-13	50	35,0	60	95	165	-4,5	-13,5	0,7	VNMU1304..

Spare Parts, Parts included in delivery

For size	Insert key	Insert pin	Insert shim
-13	T09P-2	PL1403-T09P	PVN130308

Please check availability in current price and stock-list

Toolholders for inserts WCMT



- For insert programme, see page(s) 395
- γ_0° = Rake angle, λ_s° = Inclination angle
- For holder code key, see page(s) 10-11

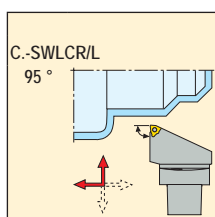
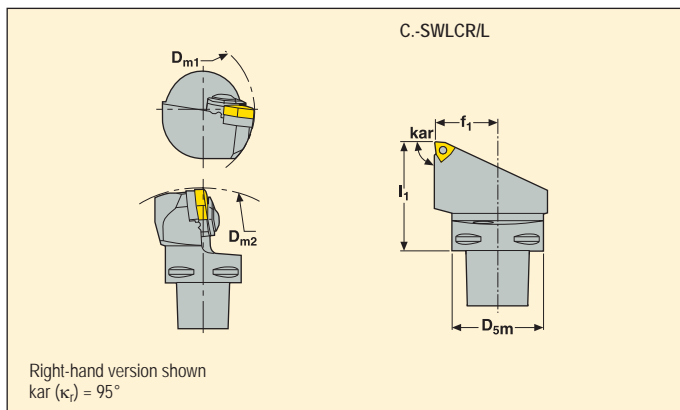

Capto size	Part No.	Dimensions in mm					γ_0°	λ_s°	KG	Insert
		D_{sm}	f_1	I_1	D_{m1}	D_{m2}				
C4	C4-SWLCR -27050-06	40	27,0	50	2,56	165	0	0	0,4	WC..06T3..
	C4-SWLCL -27050-06	40	27,0	50	2,56	165	0	0	0,4	WC..06T3..
C5	C5-SWLCR -35060-06	50	35,0	60	3,74	165	0	0	0,9	WC..06T3..
	C5-SWLCL -35060-06	50	35,0	60	3,74	165	0	0	0,9	WC..06T3..
C6	C6-SWLCR -45065-06	63	45,0	65	4,76	165	0	0	1,3	WC..06T3..
	C6-SWLCL -45065-06	63	45,0	65	–	–	0	0	1,3	WC..06T3..

Spare Parts, Parts included in delivery

For size	Insert key	Insert screw
-06	T15P-2	C03510-T15P

Please check availability in current price and stock-list

Toolholders for inserts WNGA, WNGG, WNMA, WNMG and WNNM



- For insert programme, see page(s) 396-399, 429-430
- γ_o° = Rake angle, λ_s° = Inclination angle
- For holder code key, see page(s) 10-11

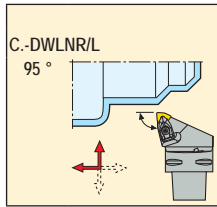
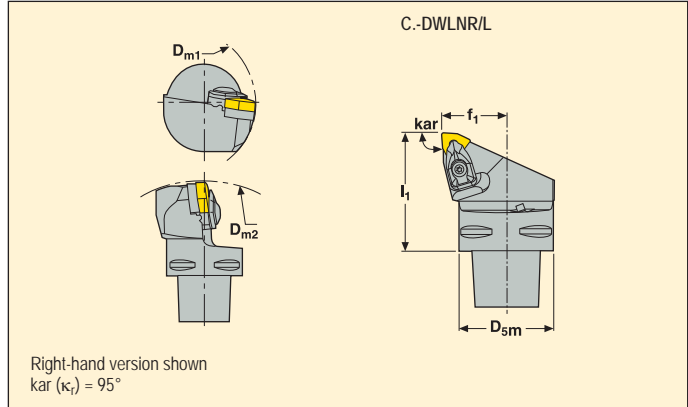

Capto size		Part No.	Dimensions in mm					γ_o°	λ_s°		
			D _{5m}	f ₁	l ₁	D _{m1}	D _{m2}				
C4	06	C4-DWLNR -27050-06	40	27,0	50	60	140	-6	-6	0,4	WN..0604..
		C4-DWLNL -27050-06	40	27,0	50	60	140	-6	-6	0,4	WN..0604..
	08	C4-DWLNR -27050-08	40	27,0	50	110	140	-6	-6	0,4	WN..0804..
		C4-DWLNL -27050-08	40	27,0	50	110	140	-6	-6	0,4	WN..0804..
C5	06	C5-DWLNR -35060-06	50	35,0	60	65	165	-6	-6	0,5	WN..0604..
		C5-DWLNL -35060-06	50	35,0	60	65	165	-6	-6	0,5	WN..0604..
	08	C5-DWLNR -35060-08	50	35,0	60	110	165	-6	-6	0,7	WN..0804..
		C5-DWLNL -35060-08	50	35,0	60	110	165	-6	-6	0,7	WN..0804..
C6	06	C6-DWLNR -45065-06	63	45,0	65	81	190	-6	-6	1,3	WN..0604..
		C6-DWLNL -45065-06	63	45,0	65	81	190	-6	-6	1,3	WN..0604..
	08	C6-DWLNR -45065-08	63	45,0	65	110	190	-6	-6	1,3	WN..0804..
		C6-DWLNL -45065-08	63	45,0	65	110	190	-6	-6	1,3	WN..0804..

Spare Parts, Parts included in delivery

For size	Clamp pin	Clamp screw	Floating wedge clamp	Insert shim	Shim/clamp key	Shim screw	Spring	Clamp kit	Insert shim
-06	FP1508	L84017-T09P	CD09-S	DWN060310	T09P-2	C03007-T09P	S5608	CD09-S09	-
-08	FP2012	L85021-T15P	CD12-S	DWN080416	T15P-2	C04008-T15P	S6912	CD12-S12	DWN080316

Accessories*

Please check availability in current price and stock-list

*To be ordered separately
Shim DWN080316 for insert WN..0806.., to be ordered separately

Toolholders for inserts WNGA, WNGG, WNMA, WNMG and WNMM



- For insert programme, see page(s) 396-399, 429-430
- γ_0° = Rake angle, λ_s° = Inclination angle
- For holder code key, see page(s) 10-11

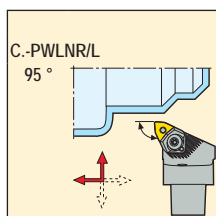
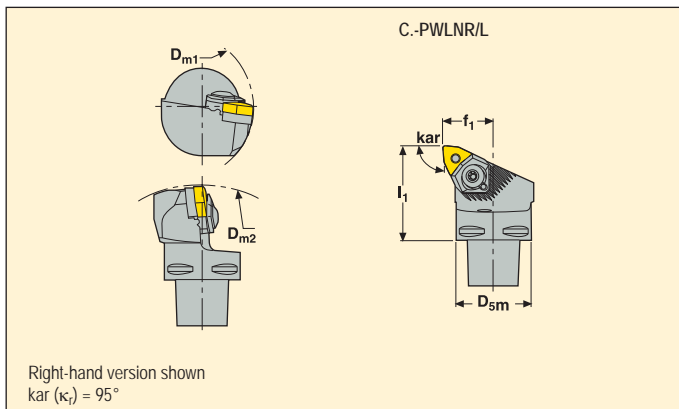

Capto size	Part No.	Dimensions in mm					γ_0°	λ_s°	KG	
		D_{sm}	f_1	l_1	D_{m1}	D_{m2}				
C4	C4-PWLNLR -27050-06	40	27,0	50	75	165	-6	-6	0,4	WN..0604..
	C4-PWLNL -27050-06	40	27,0	50	75	165	-6	-6	0,4	WN..0604..
	C4-PWLNLR -27050-08	40	27,0	50	75	165	-6	-6	0,4	WN..0804..
	C4-PWLNL -27050-08	40	27,0	50	75	165	-6	-6	0,4	WN..0804..
C5	C5-PWLNLR -35060-06	50	35,0	60	95	165	-6	-6	0,8	WN..0604..
	C5-PWLNL -35060-06	50	35,0	60	95	165	-6	-6	0,8	WN..0604..
	C5-PWLNLR -35060-08	50	35,0	60	95	165	-6	-6	0,8	WN..0804..
	C5-PWLNL -35060-08	50	35,0	60	95	165	-6	-6	0,8	WN..0804..
C6	C6-PWLNLR -45065-08	63	45,0	65	121	165	-6	-6	1,3	WN..0804..
	C6-PWLNL -45065-08	63	45,0	65	121	165	-6	-6	1,3	WN..0804..

Spare Parts, Parts included in delivery

Accessories*

For size	Insert shim	Setting screw	Shim pin	Wedge clamp	Wedge key	Wedge screw	Shim key
-06	WAE060312	L82511-T07P	PP2109-T09P	WNW06HD	T20P-7	WS1920-T20P	T09P-2
-08	WAE080412	L82511-T07P	PP2015-1-T15P	WNW08HD	T25P-7	WS2325-T25P	T15P-2

Please check availability in current price and stock-list

*To be ordered separately
 Shiml WAE080312 for insert WN..0806... to be ordered separately
 Wedge WNW08 for insert WNMM08... to be ordered separately

Toolholders for inserts CCGT, CCGW, CCMT and CCMW



- For insert programme, see page(s) 343-347, 400-401, 431-432
- γ_0 = Rake angle, λ_s = Inclination angle
- For holder code key, see page(s) 14-15

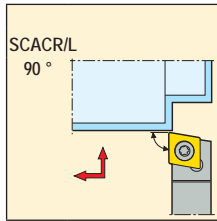
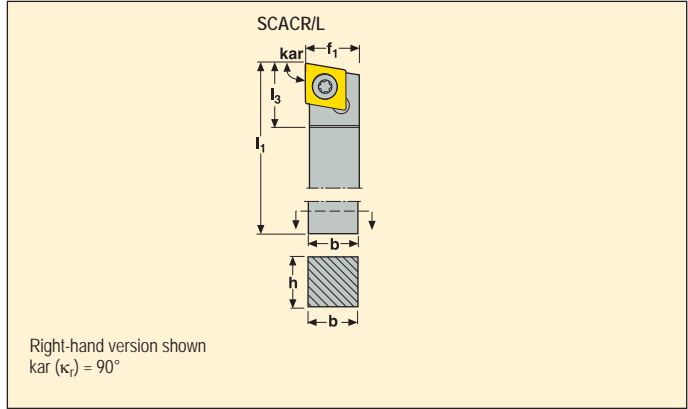

	Part No.	Dimensions in mm					γ_0°	λ_s°	KG	
		h	b	l_1	f_1	l_3				
06	SCACR 0808K06	8	8	125	8,7	9	0	0	0,1	CC..0602..
	1010M06	10	10	150	10,7	9	0	0	0,2	CC..0602..
	1212M06	12	12	150	12,7	9	0	0	0,2	CC..0602..
	SCACL 0808K06	8	8	125	8,7	9	0	0	0,1	CC..0602..
	1010M06	10	10	150	10,7	9	0	0	0,2	CC..0602..
	1212M06	12	12	150	12,7	9	0	0	0,2	CC..0602..
09	SCACR 1212M09	12	12	150	12,7	13	0	0	0,2	CC..09T3..
	1414M09	14	14	150	14,7	13	0	0	0,3	CC..09T3..
	1616H09	16	16	100	16,7	21	0	0	0,2	CC..09T3..
	SCACL 1212M09	12	12	150	12,7	13	0	0	0,2	CC..09T3..
	1414M09	14	14	150	14,7	13	0	0	0,3	CC..09T3..
	1616H09	16	16	100	16,7	21	0	0	0,2	CC..09T3..

Spare Parts, Parts included in delivery

For size	Insert key	Insert screw
...06	T07P-2	C02506-T07P
...09	T15P-2	C04008-T15P

Please check availability in current price and stock-list

Toolholders for inserts CCGT, CCMT and CCGW..-LF



- For insert programme, see page(s) 343-347, 400
- γ_0° = Rake angle, λ_s° = Inclination angle
- For holder code key, see page(s) 14-15

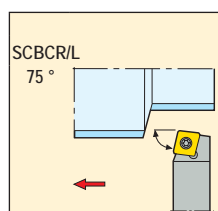
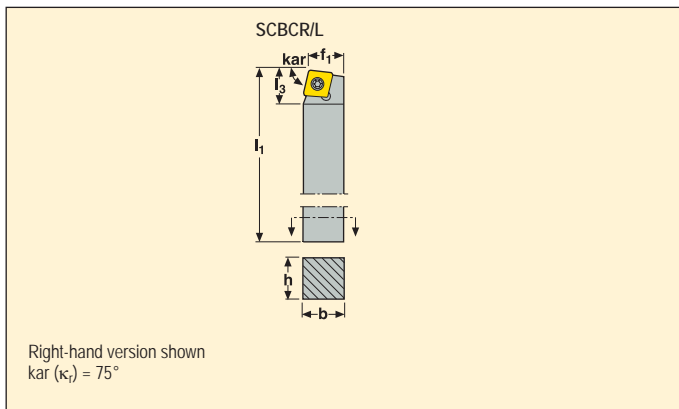

Part No.	Dimensions in mm					γ_0°	λ_s°	KG		
	h	b	l_1	f_1	l_3					
09	SCBCR 1616H09	16	16	100	13,0	12	0	0	0,2	CC..09..(-LF)
	2020K09	20	20	125	17,0	12	0	0	0,4	CC..09..(-LF)
	SCBCL 1616H09	16	16	100	13,0	12	0	0	0,2	CC..09..(-LF)
	2020K09	20	20	125	17,0	12	0	0	0,4	CC..09..(-LF)

Spare Parts, Parts included in delivery

For size	Insert key	Insert screw
...09	T15P-2	C04008-T15P

Please check availability in current price and stock-list

Toolholders for inserts CCGT, CCGW, CCMT and CCMW



- For insert programme, see page(s) 343-347, 400-401, 431-432
- γ_0° = Rake angle, λ_{s° = Inclination angle
- For holder code key, see page(s) 14-15

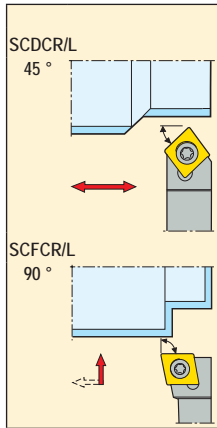
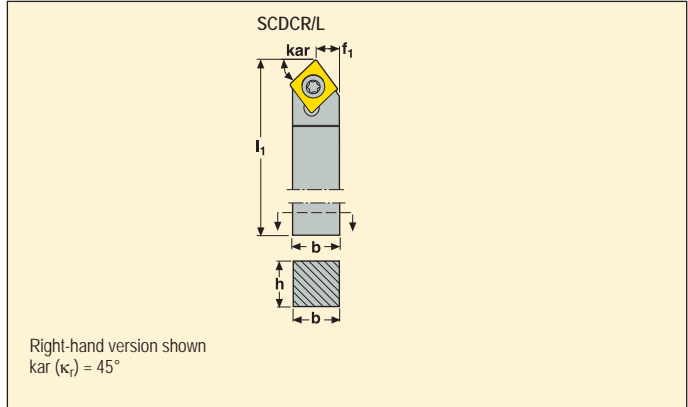

	Part No.	Dimensions in mm					γ_0°	λ_{s°	KG	
		h	b	l_1	f_1	l_3				
06	SDCR 0808K06	8	8	125	4,2	11	0	0	0,1	CC..0602..
	1010M06	10	10	150	5,2	11	0	0	0,2	CC..0602..
	SCDCL 0808K06	8	8	125	4,2	11	0	0	0,1	CC..0602..
	1010M06	10	10	150	5,2	11	0	0	0,2	CC..0602..
09	SDCR 1212M09	12	12	150	6,2	21	0	0	0,2	CC..09T3..
	1414M09	14	14	150	7,2	21	0	0	0,3	CC..09T3..
	SCDCL 1212M09	12	12	150	6,2	21	0	0	0,2	CC..09T3..
	1414M09	14	14	150	7,2	21	0	0	0,3	CC..09T3..
06	SCFCR 0808D06	8	8	60	10,0	9	0	0	0,1	CC..0602..
09	SCFCR 1212F09	12	12	80	16,0	15	0	0	0,1	CC..09T3..
	SCFCL 1212F09	12	12	80	16,0	15	0	0	0,1	CC..09T3..

Spare Parts, Parts included in delivery

For size	Insert key	Insert screw
...06	T07P-2	C02506-T07P
...09	T15P-2	C04008-T15P

Please check availability in current price and stock-list

Toolholders for inserts CCGT, CCGW, CCMT and CCMW



- For insert programme, see page(s) 343-347, 400-401, 431-432
- γ_0° = Rake angle, λ_s° = Inclination angle
- For holder code key, see page(s) 14-15

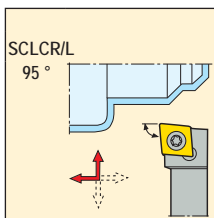
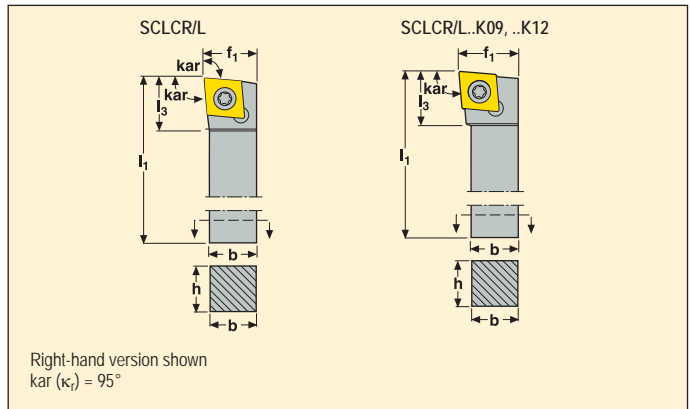

	Part No.	Dimensions in mm					γ_0°	λ_s°	KG	
		h	b	l ₁	f ₁	l ₃				
06	SCLCR 0808K06	8	8	125	8,5	9	0	0	0,1	CC..0602..
	1010M06	10	10	150	10,5	9	0	0	0,2	CC..0602..
	1212M06	12	12	150	12,5	8	0	0	0,2	CC..0602..
	SCLCL 0808K06	8	8	125	8,5	9	0	0	0,1	CC..0602..
	1010M06	10	10	150	10,5	9	0	0	0,2	CC..0602..
	1212M06	12	12	150	12,5	8	0	0	0,2	CC..0602..
09	SCLCR 1212M09	12	12	150	12,5	12	0	0	0,2	CC..09T3..
	1616H09	16	16	100	16,5	12	0	0	0,2	CC..09T3..
	2020K09	20	20	125	25,0	20	0	0	0,4	CC..09T3..
	SCLCL 1212M09	12	12	150	12,5	12	0	0	0,2	CC..09T3..
	1616H09	16	16	100	16,5	12	0	0	0,3	CC..09T3..
	2020K09	20	20	125	25,0	20	0	0	0,5	CC..09T3..
12	SCLCR 2020K12	20	20	125	25,0	20	0	0	0,4	CC..1204..
	SCLCL 2020K12	20	20	125	25,0	20	0	0	0,4	CC..1204..

Spare Parts, Parts included in delivery

For size	Insert key	Insert screw	Insert shim	Shim screw
...06	T07P-2	C02506-T07P	-	-
...09	T15P-2	C04008-T15P	-	-
...12	T15P-2	C05012-T15P	123.19-621	CA5008

Accessories, to be ordered separately

Shim key
-
-
5SMS795

Please check availability in current price and stock-list

Turning – Toolholders, ext.

Toolholders for inserts CCGT, CCGW, CCMT and CCMW



- For insert programme, see page(s) 343-347, 400-401, 431-432
- γ_0° = Rake angle, λ_s° = Inclination angle
- For holder code key, see page(s) 14-15

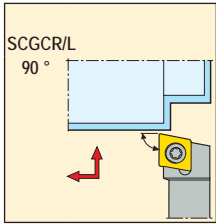
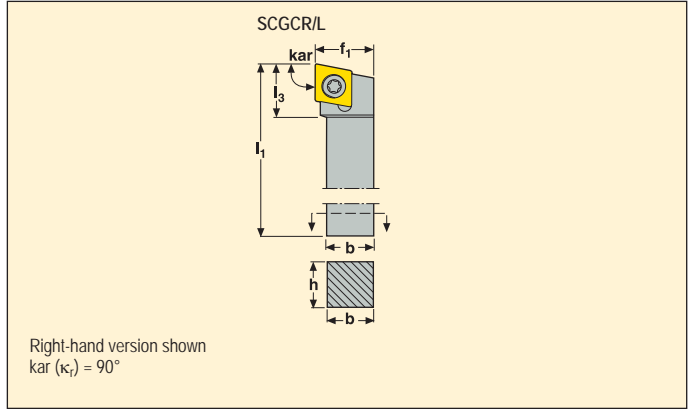

	Part No.	Dimensions in mm					γ_0°	λ_s°	KG	
		h	b	l_1	f_1	l_3				
06	SCGCR 0808D06	8	8	60	10,0	11	0	0	0,1	CC..0602..
	1010E06	10	10	70	12,0	11	0	0	0,1	CC..0602..
	SCGCL 1010E06	10	10	70	12,0	11	0	0	0,1	CC..0602..
09	SCGCR 1212F09	12	12	80	16,0	15	0	0	0,1	CC..09T3..
	SCGCL 1212F09	12	12	80	16,0	15	0	0	0,1	CC..09T3..

Spare Parts, Parts included in delivery

For size	Insert key	Insert screw
...06	T07P-2	C02506-T07P
...09	T15P-2	C04008-T15P

Please check availability in current price and stock-list

Toolholders for inserts CNGG, CNMA, CNMG and CNMM



- For insert programme, see page(s) 348-355
- γ_0° = Rake angle, λ_s° = Inclination angle
- For holder code key, see page(s) 14-15

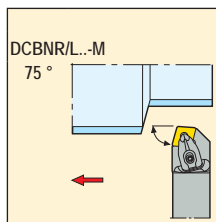
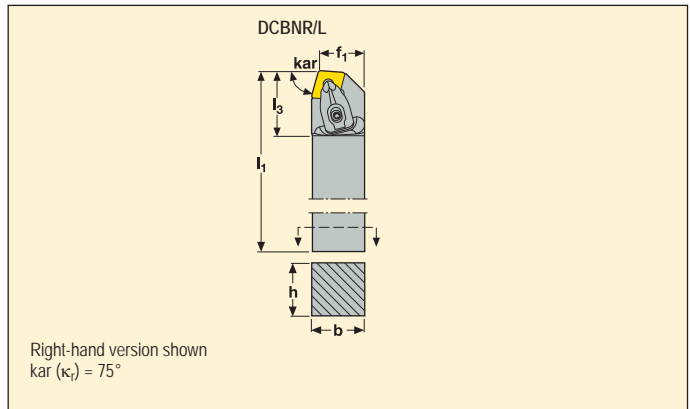

	Part No.	Dimensions in mm					γ_0°	λ_s°	KG	
		h	b	l_1	f_1	l_3				
12	DCBNR 2020K12-M	20	20	125	17,0	32	-6	-6	0,4	CN..1204..
	2525M12-M	25	25	150	22,0	31	-6	-6	0,8	CN..1204..
	3225P12-M	32	25	170	22,0	31	-6	-6	1,1	CN..1204..
	DCBNL 2020K12-M	20	20	125	17,0	32	-6	-6	0,4	CN..1204..
	2525M12-M	25	25	150	22,0	31	-6	-6	0,8	CN..1204..
	3225P12-M	32	25	170	22,0	31	-6	-6	1,1	CN..1204..
16	DCBNR 2525M16-M	25	25	150	22,0	41	-6	-6	0,8	CN..1606..
	3225P16-M	32	25	170	22,0	42	-6	-6	1,1	CN..1606..
	DCBNL 2525M16-M	25	25	150	22,0	41	-6	-6	0,8	CN..1606..
	3225P16-M	32	25	170	22,0	42	-6	-6	1,1	CN..1606..
19	DCBNR 3232P19-M	32	32	170	27,0	41	-6	-6	1,4	CN..1906..
	4040R19-M	40	40	200	35,0	42	-6	-6	2,5	CN..1906..
	DCBNL 3232P19-M	32	32	170	27,0	41	-6	-6	1,4	CN..1906..
	4040R19-M	40	40	200	35,0	42	-6	-6	2,5	CN..1906..

Spare Parts, Parts included in delivery

Accessories*

For size	Clamp pin	Clamp screw	Floating wedge clamp	Insert shim	Shim/clamp key	Shim screw	Spring	Clamp kit
...12	FP2012	L85021-T15P	CD12-S	DCN120616	T15P-7	C04008-T15P	S6912	CD12-S12
...16	FP2012	L86026-T20P	CD16-S	DCN160616	T20P-7L	C05010-T20P	S7010	CD16-S16
...19	FP2012	L86026-T20P	CD19-S	DCN190416	T20P-7L	C05010-T20P	S7010	CD19-S19

Please check availability in current price and stock-list

*To be ordered separately
Shim DCN120416 for insert CN..1206.., to be ordered separately

Toolholders for inserts CNGG, CNMA, CNMG and CNMM



- For insert programme, see page(s) 348-355
- γ_0° = Rake angle, λ_{s° = Inclination angle
- For holder code key, see page(s) 14-15

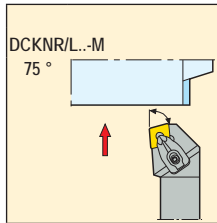
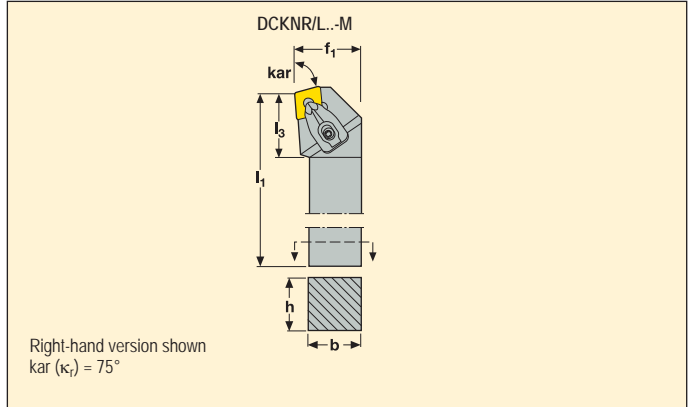

	Part No.	Dimensions in mm					γ_0°	λ_{s°	KG	
		h	b	l_1	f_1	l_3				
09	DCKNR 2525M09-M	25	25	150	32,0	30	-6	-6	0,8	CN..0903..
	DCKNL 2525M09-M	25	25	150	32,0	30	-6	-6	0,8	CN..0903..
12	DCKNR 2020K12-M	20	20	125	25,0	30	-6	-6	0,5	CN..1204..
	2525M12-M	25	25	150	32,0	31	-6	-6	0,8	CN..1204..
	3225P12-M	32	25	170	32,0	31	-6	-6	1,1	CN..1204..
	DCKNL 2020K12-M	20	20	125	25,0	30	-6	-6	0,5	CN..1204..
	2525M12-M	25	25	150	32,0	31	-6	-6	0,8	CN..1204..
	3225P12-M	32	25	170	32,0	31	-6	-6	1,1	CN..1204..
16	DCKNR 2525M16-M	25	25	150	32,0	36	-6	-6	0,8	CN..1606..
	3225P16-M	32	25	170	32,0	36	-6	-6	1,2	CN..1606..
	DCKNL 2525M16-M	25	25	150	32,0	36	-6	-6	0,8	CN..1606..
	3225P16-M	32	25	170	32,0	36	-6	-6	1,2	CN..1606..
19	DCKNR 3225P19-M	32	25	170	32,0	36	-6	-6	1,2	CN..1906..
	3232P19-M	32	32	170	40,0	36	-6	-6	1,5	CN..1906..
	DCKNL 3225P19-M	32	25	170	32,0	36	-6	-6	1,2	CN..1906..
	3232P19-M	32	32	170	40,0	36	-6	-6	1,5	CN..1906..

Spare Parts, Parts included in delivery

Accessories*

For size	Clamp pin	Clamp screw	Floating wedge clamp	Insert shim	Shim/clamp key	Shim screw	Spring	Clamp kit
...09	FP1508	L84017-T09P	CD09-S	DCN090310	T09P-2	C03007-T09P	S5608	CD09-S09
...12	FP2012	L85021-T15P	CD12-S	DCN120616	T15P-7	C04008-T15P	S6912	CD12-S12
...16	FP2012	L86026-T20P	CD16-S	DCN160616	T20P-7L	C05010-T20P	S7010	CD16-S16
...19	FP2012	L86026-T20P	CD19-S	DCN190416	T20P-7L	C05010-T20P	S7010	CD19-S19

Please check availability in current price and stock-list

*To be ordered separately
Shim DCN120416 for insert CN..1206.., to be ordered separately

Toolholders for inserts CNGA, CNGG, CNMA, CNMG and CNMM



- For insert programme, see page(s) 348-355, 402, 431
- γ_0° = Rake angle, λ_s° = Inclination angle
- For holder code key, see page(s) 14-15

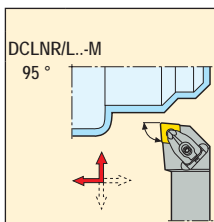
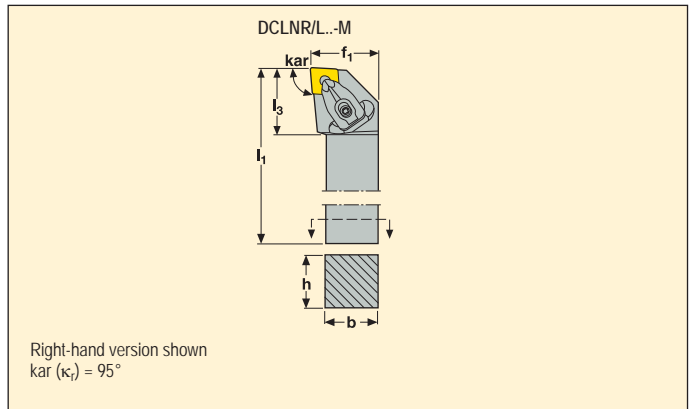

	Part No.	Dimensions in mm					γ_0°	λ_s°	KG	
		h	b	l_1	f_1	l_3				
09	DCLNR 1616H09-M	16	16	100	20,0	25	-6	-6	0,3	CN..0903..
	2020K09-M	20	20	125	25,0	23	-6	-6	0,4	CN..0903..
	2525M09-M	25	25	150	32,0	25	-6	-6	0,8	CN..0903..
	DCLNL 1616H09-M	16	16	100	20,0	25	-6	-6	0,3	CN..0903..
	2525M09-M	25	25	150	32,0	25	-6	-6	0,8	CN..0903..
	2020K09-M	20	20	125	25,0	23	-6	-6	0,4	CN..0903..
12	DCLNR 2020K12-M	20	20	125	25,0	32	-6	-6	0,4	CN..1204..
	2525M12-M	25	25	150	32,0	32	-6	-6	0,8	CN..1204..
	3225P12-M	32	25	170	32,0	32	-6	-6	1,1	CN..1204..
	3232P12-M	32	32	170	40,0	32	-6	-6	1,4	CN..1204..
	DCLNL 2020K12-M	20	20	125	25,0	32	-6	-6	0,4	CN..1204..
	2525M12-M	25	25	150	32,0	32	-6	-6	0,8	CN..1204..
	3225P12-M	32	25	170	32,0	32	-6	-6	1,1	CN..1204..
3232P12-M	32	32	170	40,0	32	-6	-6	1,4	CN..1204..	

Spare Parts, Parts included in delivery

Accessories*

For size	Clamp pin	Clamp screw	Floating wedge clamp	Insert shim	Shim/clamp key	Shim screw	Spring	Clamp kit
...09	FP1508	L84017-T09P	CD09-S	DCN090310	T09P-2	C03007-T09P	S5608	CD09-S09
...12	FP2012	L85021-T15P	CD12-S	DCN120616	T15P-7	C04008-T15P	S6912	CD12-S12

Please check availability in current price and stock-list

*To be ordered separately
Shim DCN120416 for insert CN..1206.., to be ordered separately

Toolholders for inserts CNGA, CNGG, CNMA, CNMG and CNMM



- For insert programme, see page(s) 348-355
- γ_0° = Rake angle, λ_s° = Inclination angle
- For holder code key, see page(s) 14-15

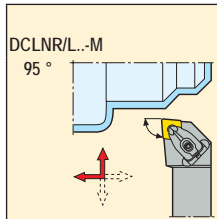
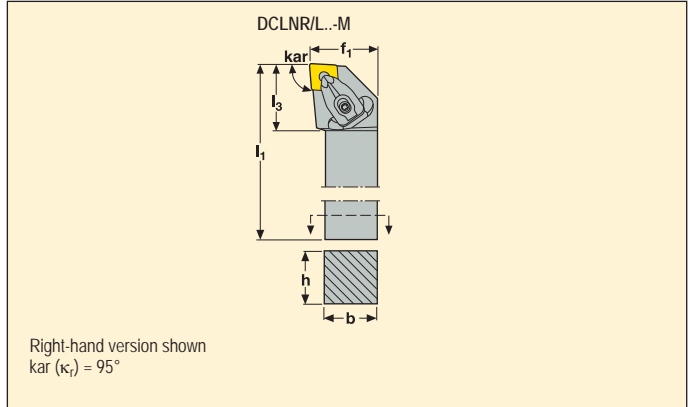

	Part No.	Dimensions in mm					γ_0°	λ_s°	KG	Key
		h	b	l_1	f_1	l_3				
16	DCLNR 2525M16-M	25	25	150	32,0	40	-6	-6	0,8	CN..1606..
	3225P16-M	32	25	170	32,0	42	-6	-6	1,1	CN..1606..
	3232P16-M	32	32	170	40,0	42	-6	-6	1,4	CN..1606..
	DCLNL 2525M16-M	25	25	150	32,0	40	-6	-6	0,8	CN..1606..
	3225P16-M	32	25	170	32,0	42	-6	-6	1,1	CN..1606..
	3232P16-M	32	32	170	40,0	42	-6	-6	1,4	CN..1606..
19	DCLNR 3225P19-M	32	25	170	32,0	42	-6	-6	1,1	CN..1906..
	3232P19-M	32	32	170	40,0	42	-6	-6	1,4	CN..1906..
	4040R19-M	40	40	200	50,0	40	-6	-6	2,5	CN..1906..
	DCLNL 3225P19-M	32	25	170	32,0	42	-6	-6	1,1	CN..1906..
	3232P19-M	32	32	170	40,0	42	-6	-6	1,4	CN..1906..
	4040R19-M	40	40	200	50,0	40	-6	-6	2,5	CN..1906..

Spare Parts, Parts included in delivery

Accessories*

For size	Clamp pin	Clamp screw	Floating wedge clamp	Insert shim	Shim/clamp key	Shim screw	Spring	Clamp kit
...16	FP2012	L86026-T20P	CD16-S	DCN160616	T20P-7L	C05010-T20P	S7010	CD16-S16
...19	FP2012	L86026-T20P	CD19-S	DCN190416	T20P-7L	C05010-T20P	S7010	CD19-S19

Please check availability in current price and stock-list

*To be ordered separately

Toolholders for inserts CNGG, CNMA, CNMG and CNMM



- For insert programme, see page(s) 349-355
- γ_0° = Rake angle, λ_s° = Inclination angle
- For holder code key, see page(s) 14-15

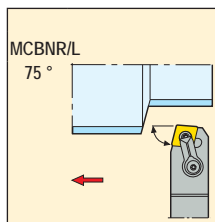
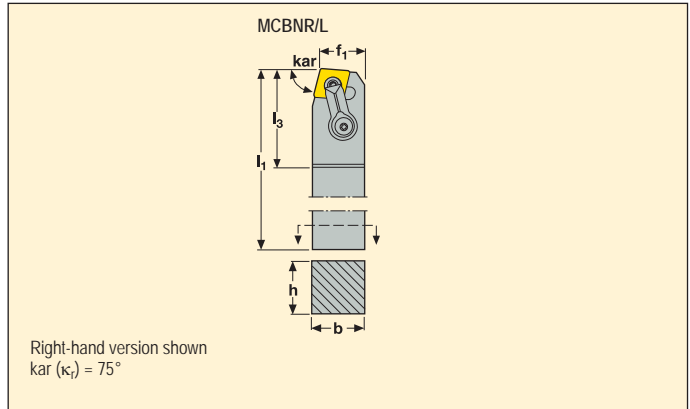

	Part No.	Dimensions in mm					γ_0°	λ_s°	KG	
		h	b	l ₁	f ₁	l ₃				
19	MCBNR 3232P19	32	32	170	27,0	40	-6	-6	1,4	CN..1906..
	4040R19	40	40	200	35,0	40	-6	-6	2,5	CN..1906..
	MCBNL 3232P19	32	32	170	27,0	40	-6	-6	1,4	CN..1906..
	4040R19	40	40	200	35,0	40	-6	-6	2,5	CN..1906..

Spare Parts, Parts included in delivery

For size	Cantilever clamp	Clamp key	Clamp screw	Insert shim	Shim pin
...19	MC22	T20P-7L	LD6024-T20P	CSN190412	MN1920-T20P

Please check availability in current price and stock-list

Toolholders for inserts CNGG, CNMA, CNMG and CNMM



- For insert programme, see page(s) 349-355
- γ_0° = Rake angle, λ_s° = Inclination angle
- For holder code key, see page(s) 14-15

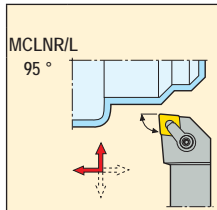
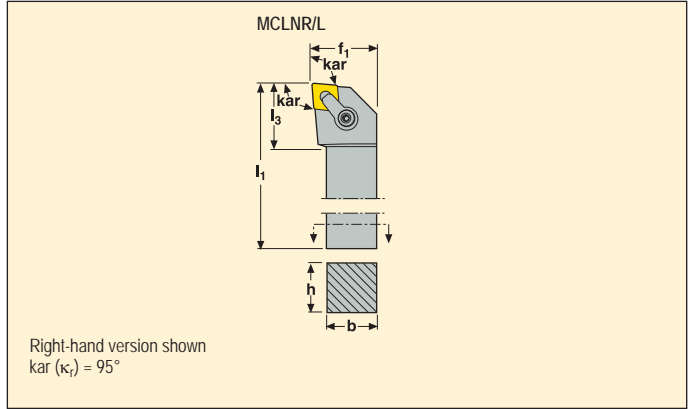

	Part No.	Dimensions in mm					γ_0°	λ_s°	KG	Icon
		h	b	l ₁	f ₁	l ₃				
16	MCLNR 2525M16	25	25	150	32,0	35	-6	-6	0,8	CN..1606..
	3225P16	32	25	170	32,0	35	-6	-6	1,1	CN..1606..
	3232P16	32	32	170	40,0	35	-6	-6	1,4	CN..1606..
	MCLNL 2525M16	25	25	150	32,0	35	-6	-6	0,8	CN..1606..
	3225P16	32	25	170	32,0	35	-6	-6	1,1	CN..1606..
	3232P16	32	32	170	40,0	35	-6	-6	1,4	CN..1606..
19	MCLNR 3232P19	32	32	170	40,0	40	-6	-6	1,4	CN..1906..
	4040R19	40	40	200	50,0	40	-6	-6	2,5	CN..1906..
	MCLNL 3232P19	32	32	170	40,0	40	-6	-6	1,4	CN..1906..
	4040R19	40	40	200	50,0	40	-6	-6	2,5	CN..1906..

Spare Parts, Parts included in delivery

For size	Cantilever clamp	Clamp key	Clamp screw	Insert shim	Shim pin
...16	MC21	T20P-7L	LD6024-T20P	CSN160412	MN1520-T20P
...19	MC22	T20P-7L	LD6024-T20P	CSN190412	MN1920-T20P

Accessories*

Shim screw
CSC8015-T20P
CSC1015-T20P

Please check availability in current price and stock-list

*To be ordered separately

Toolholders for inserts CNGA, CNGG, CNMA, CNMG and CNMM



- For insert programme, see page(s) 348-355, 402, 431
- γ_0° = Rake angle, λ_s° = Inclination angle
- For holder code key, see page(s) 14-15

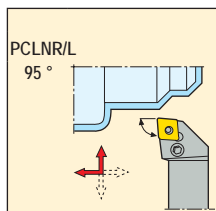
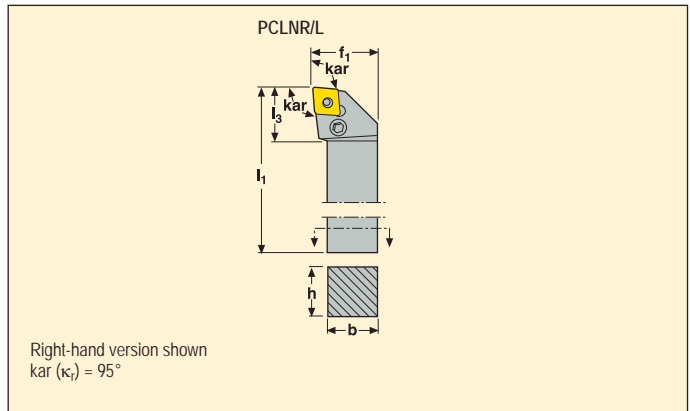

	Part No.	Dimensions in mm					γ_0°	λ_s°	KG	
		h	b	l_1	f_1	l_3				
12	PCLNR 2020K12	20	20	125	25,0	26	-6	-6	0,4	CN..1204..
	2525M12	25	25	150	32,0	26	-6	-6	0,8	CN..1204..
	3225P12	32	25	170	32,0	26	-6	-6	1,1	CN..1204..
	PCLNL 2020K12	20	20	125	25,0	26	-6	-6	0,4	CN..1204..
	2525M12	25	25	150	32,0	26	-6	-6	0,8	CN..1204..
	3225P12	32	25	170	32,0	26	-6	-6	1,1	CN..1204..
16	PCLNR 2525M16	25	25	150	32,0	34	-6	-6	0,8	CN..1606..
	3232P16	32	32	170	40,0	34	-6	-6	1,4	CN..1606..
	PCLNL 2525M16	25	25	150	32,0	34	-6	-6	0,8	CN..1606..
	3232P16	32	32	170	40,0	34	-6	-6	1,4	CN..1606..
19	PCLNR 3232P19	32	32	170	40,0	37	-6	-6	0,1	CN..1906..
	4040S19	40	40	250	50,0	38	-6	-6	1,5	CN..1906..
	PCLNL 3232P19	32	32	170	40,0	37	-6	-6	0,1	CN..1906..
	4040S19	40	40	250	50,0	38	-6	-6	3,1	CN..1906..
25	PCLNR 4040S25	40	40	250	50,2	48	-6	-6	3,1	CN..2509..
	PCLNL 4040S25	40	40	250	50,2	48	-6	-6	3,1	CN..2509..

Spare Parts, Parts included in delivery

For size	Insert lever	Insert shim	Lever key	Lever screw	Punch	Shim pin
...12	PP4713	PCN120308	3SMS795	LS0818	MP0912	RP6757
...16	PP6017	PCN160412	3SMS795	LS0820	MP1519	RP8286
...19	PP7521	PCN190416	4SMS795	LS1027	MP1519	RP9811
...25	PP1325	PCN250620	5SMS795	LS1236	MP25	RP1312

Please check availability in current price and stock-list

Turning – Toolholders, ext.

Toolholders for inserts CNGA, CNGG, CNMA, CNMG and CNMM

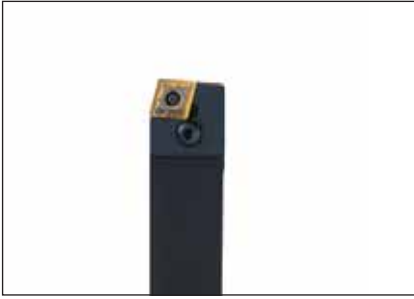

- For insert programme, see page(s) 348-355, 402, 431
- γ_0° = Rake angle, λ_s° = Inclination angle
- For holder code key, see page(s) 14-15

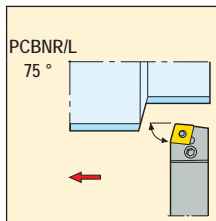
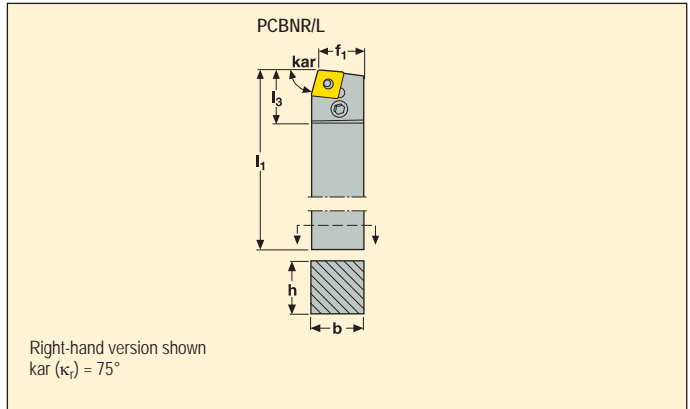

	Part No.	Dimensions in mm					γ_0°	λ_s°	KG	
		h	b	l ₁	f ₁	l ₃				
12	PCBNR 2525M12	25	25	150	22,0	26	-6	-6	0,7	CN..1204..
	PCBNL 2525M12	25	25	150	22,0	26	-6	-6	0,7	CN..1204..
19	PCBNR 3232P19	32	32	171	40,0	37	-6	-6	1,3	CN..1906..
	4040S19	40	40	251	35,0	38	-6	-6	3,1	CN..1906..
	PCBNL 3232P19	32	32	171	40,0	37	-6	-6	1,3	CN..1906..
	4040S19	40	40	251	35,0	38	-6	-6	3,1	CN..1906..

Spare Parts, Parts included in delivery

For size	Insert lever	Insert shim	Lever key	Lever screw	Punch	Shim pin
...12	PP4713	PCN120308	3SMS795	LS0818	MP0912	RP6757
...19	PP7521	PCN190416	4SMS795	LS1027	MP1519	RP9811

Please check availability in current price and stock-list

Toolholders for PCBN inserts CNGN and CNMM



- For insert programme, see page(s) 403, 436
- γ_0° = Rake angle, λ_s° = Inclination angle
- For holder code key, see page(s) 14-15

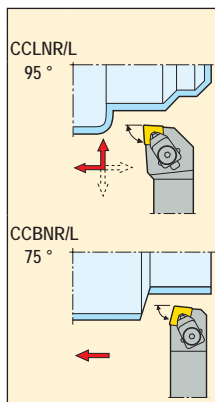
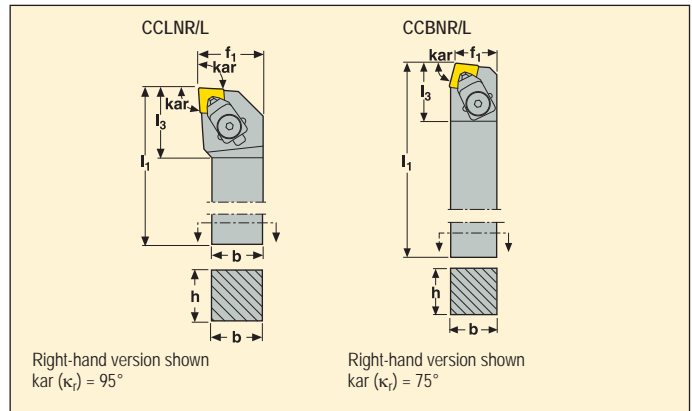

	Part No.	Dimensions in mm					γ_0°	λ_s°	KG	
		h	b	l_1	f_1	l_3				
09	CCLNR 2525M09	25	25	150	32,0	27	-6	-6	0,8	CN.N0903..
	3225P09	32	25	170	32,0	27	-6	-6	1,1	CN.N0903..
	CCLNL 2525M09	25	25	150	32,0	27	-6	-6	0,8	CN.N0903..
	3225P09	32	25	170	32,0	27	-6	-6	1,1	CN.N0903..
12	CCLNR 2525M12	25	25	150	32,0	34	-6	-6	0,8	CN.N1204..
	3225P12	32	25	170	32,0	34	-6	-6	1,1	CN.N1204..
	CCLNL 2525M12	25	25	150	32,0	34	-6	-6	0,8	CN.N1204..
	3225P12	32	25	170	32,0	34	-6	-6	1,1	CN.N1204..
09	CCBNR 2525M09	25	25	150	22,0	30	-6	-6	0,8	CN.N0903..
	CCBNL 2525M09	25	25	150	22,0	30	-6	-6	0,8	CN.N0903..
12	CCBNR 2525M12	25	25	150	22,0	34	-6	-6	0,8	CN.N1204..
	3225P12	32	25	170	22,0	34	-6	-6	1,1	CN.N1204..
	CCBNL 2525M12	25	25	150	22,0	34	-6	-6	0,8	CN.N1204..

Spare Parts, Parts included in delivery

Accessories*

For size	Cantilever clamp	Clamp key	Insert shim	Pressure plate	Shim screw	Shim key
...09	CC17P-09	4SMS795	CCN090412	P1311-09	174.10-652-T07P	T07P-2
...12	CC17P	4SMS795	CCN120312	P1311	F94009-T09P	T09P-2

Please check availability in current price and stock-list

*To be ordered separately

Toolholders for inserts DCGT, DCGW, DCMT and DCMW



- For insert programme, see page(s) 356-359, 404, 433
- γ_0° = Rake angle, λ_s° = Inclination angle
- For holder code key, see page(s) 14-15

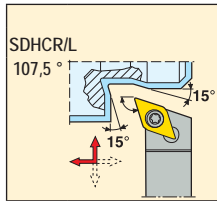
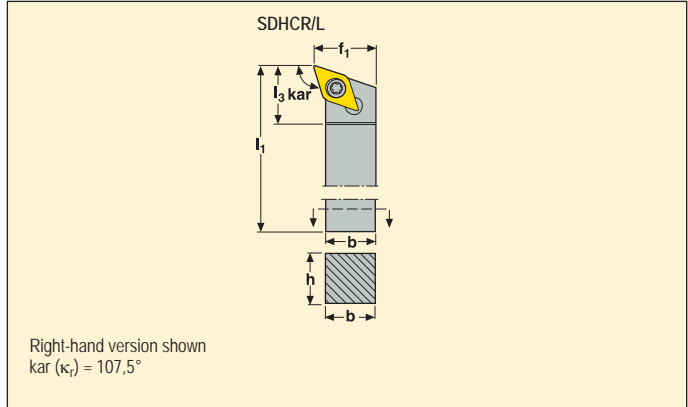

	Part No.	Dimensions in mm					γ_0°	λ_s°	KG	
		h	b	l_1	f_1	l_3				
07	SDHCR 1010M07	10	10	150	12,0	14	0	0	0,2	DC..0702..
	SDHCL 1010M07	10	10	150	12,0	14	0	0	0,2	DC..0702..
11	SDHCR 1212M11	12	12	150	16,0	21	0	0	0,2	DC..11T3..
	1616H11	16	16	100	20,0	20	0	0	0,2	DC..11T3..
	2020K11	20	20	125	25,0	20	0	0	0,4	DC..11T3..
	2525M11	25	25	150	32,0	20	0	0	0,8	DC..11T3..
	SDHCL 1212M11	12	12	150	16,0	21	0	0	0,2	DC..11T3..
	1616H11	16	16	100	20,0	20	0	0	0,2	DC..11T3..
	2020K11	20	20	125	25,0	20	0	0	0,4	DC..11T3..
	2525M11	25	25	150	32,0	20	0	0	0,8	DC..11T3..
15	SDHCR 2525M15	25	25	150	32,0	25	0	0	0,7	DC..1504..
	SDHCL 2525M15	25	25	150	32,0	25	0	0	0,7	DC..1504..

Spare Parts, Parts included in delivery

Accessories, to be ordered separately

For size	Insert key	Insert screw	Insert shim	Shim screw	Shim key
..07	T07P-2	C02506-T07P	-	-	-
..1212.11/..1616.11	T15P-2	C04008-T15P	-	-	-
..2020.11/..2525.11	T15P-2	C03510-T15P	126.19-620	CA3510	9/64SMS875
...15	T15P-2	C04518-T15P	126.19-621	CA4512	5SMS795

Please check availability in current price and stock-list

Toolholders for inserts DCGT, DCGW, DCMT, DCMW and DCMX



- For insert programme, see page(s) 356-359, 404, 433
- γ_0° = Rake angle, λ_s° = Inclination angle
- For holder code key, see page(s) 14-15

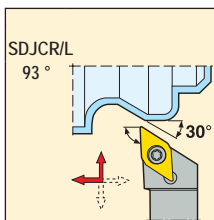
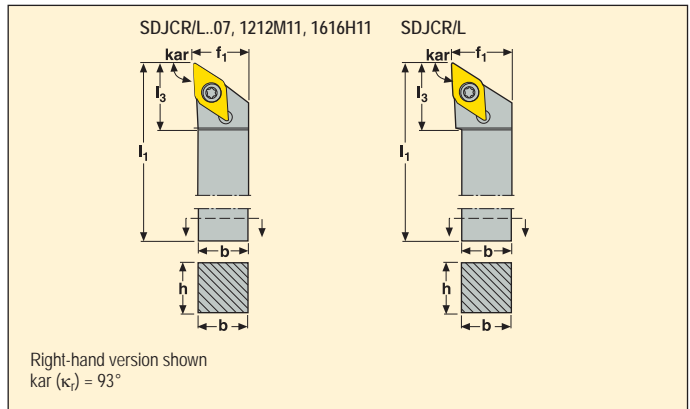

	Part No.	Dimensions in mm					γ_0°	λ_s°	KG	Key
		h	b	l_1	f_1	l_3				
07	SDJCR 0808K07	8	8	125	8,5	13	0	0	0,1	DC..0702..
	1010M07	10	10	150	10,5	14	0	0	0,2	DC..0702..
	1212M07	12	12	150	12,5	13	0	0	0,2	DC..0702..
	SDJCL 0808K07	8	8	125	8,5	13	0	0	0,1	DC..0702..
	1010M07	10	10	150	10,5	14	0	0	0,2	DC..0702..
	1212M07	12	12	150	12,5	13	0	0	0,2	DC..0702..
11	SDJCR 1212M11	12	12	150	12,5	20	0	0	0,2	DC..11T3..
	1616H11	16	16	100	16,5	20	0	0	0,2	DC..11T3..
	2020K11	20	20	125	25,0	20	0	0	0,4	DC..11T3..
	2525M11	25	25	150	32,0	20	0	0	0,7	DC..11T3..
	SDJCL 1212M11	12	12	150	12,5	20	0	0	0,2	DC..11T3..
	1616H11	16	16	100	16,5	20	0	0	0,2	DC..11T3..
	2020K11	20	20	125	25,0	20	0	0	0,4	DC..11T3..
2525M11	25	25	150	32,0	20	0	0	0,7	DC..11T3..	
15	SDJCR 2525M15	25	25	150	32,0	28	0	0	0,7	DC..1504..
	3225P15	32	25	170	32,0	28	0	0	1,1	DC..1504..
	SDJCL 2525M15	25	25	150	32,0	28	0	0	0,7	DC..1504..
	3225P15	32	25	170	32,0	28	0	0	1,1	DC..1504..

Spare Parts, Parts included in delivery

For size	Insert key	Insert screw	Insert shim	Shim screw	Shim key
...07	T07P-2	C02506-T07P	-	-	-
...1212.11/...1616.11	T15P-2	C04008-T15P	-	-	-
...2020.11/...2525.11	T15P-2	C03510-T15P	126.19-620	CA3510	9/64SMS875
...15	T15P-2	C04518-T15P	126.19-621	CA4512	5SMS795

Accessories, to be ordered separately

Please check availability in current price and stock-list

Toolholders for inserts DCGT, DCGW, DCMT and DCMW



- For insert programme, see page(s) 356-359, 404, 433
- γ_0° = Rake angle, λ_s° = Inclination angle
- For holder code key, see page(s) 14-15

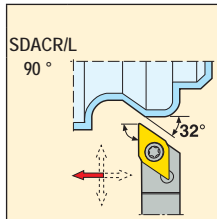
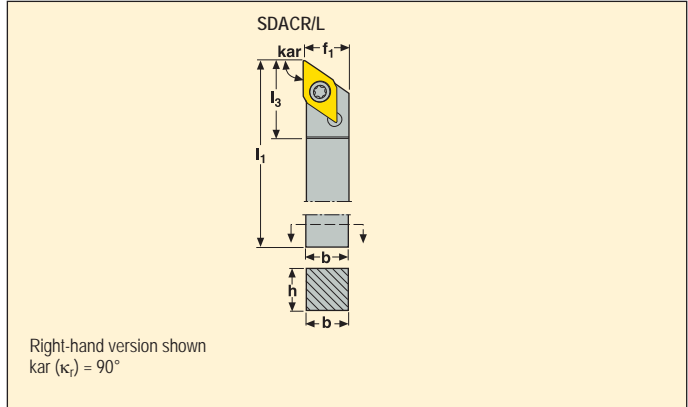

	Part No.	Dimensions in mm					γ_0°	λ_s°	KG	
		h	b	l_1	f_1	l_3				
07	SDACR 0808K07	8	8	125	8,7	13	0	0	0,1	DC..0702..
	1010M07	10	10	150	10,7	13	0	0	0,2	DC..0702..
	1212M07	12	12	150	12,7	13	0	0	0,2	DC..0702..
	SDACL 0808K07	8	8	125	8,7	13	0	0	0,1	DC..0702..
	1010M07	10	10	150	10,7	13	0	0	0,2	DC..0702..
	1212M07	12	12	150	12,7	13	0	0	0,2	DC..0702..
11	SDACR 1212M11	12	12	150	12,7	20	0	0	0,2	DC..11T3..
	1414M11	14	14	150	14,7	20	0	0	0,3	DC..11T3..
	1616H11	16	16	100	16,7	21	0	0	0,2	DC..11T3..
	SDACL 1212M11	12	12	150	12,7	20	0	0	0,2	DC..11T3..
	1414M11	14	14	150	14,7	20	0	0	0,3	DC..11T3..
	1616H11	16	16	100	16,7	21	0	0	0,2	DC..11T3..

Spare Parts, Parts included in delivery

For size	Insert key	Insert screw
...07	T07P-2	C02506-T07P
...11	T15P-2	C04008-T15P

Please check availability in current price and stock-list

Toolholders for inserts DCGT, DCGW, DCMT and DCMW



- For insert programme, see page(s) 356-359, 404, 433
- γ_0° = Rake angle, λ_s° = Inclination angle
- For holder code key, see page(s) 14-15

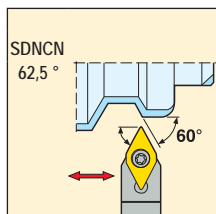
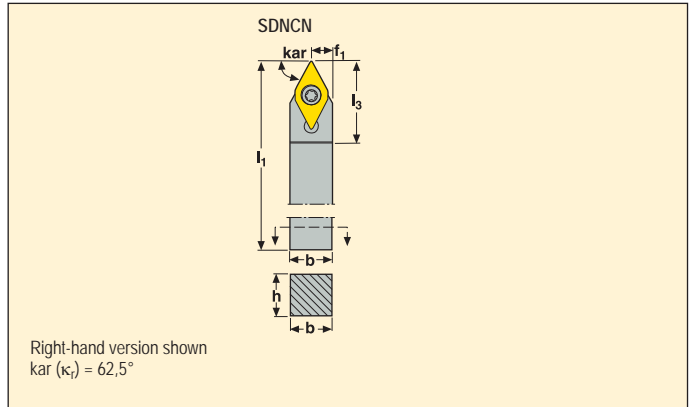

	Part No.	Dimensions in mm					γ_0°	λ_s°	KG	
		h	b	l_1	f_1	l_3				
07	SDNCN 0808K07	8	8	125	4,2	16	0	0	0,1	DC..0702..
	1010M07	10	10	150	5,2	21	0	0	0,2	DC..0702..
	1212M07	12	12	150	6,2	20	0	0	0,2	DC..0702..
11	SDNCN 1212M11	12	12	150	6,2	23	0	0	0,2	DC..11T3..
	1414M11	14	14	150	7,2	23	0	0	0,3	DC..11T3..
	1616H11	16	16	100	8,2	22	0	0	0,2	DC..11T3..
	2020K11	20	20	125	10,2	22	0	0	0,4	DC..11T3..
	2525M11	25	25	150	12,7	23	0	0	0,7	DC..11T3..
15	SDNCN 2020K15	20	20	125	10,2	29	0	0	0,4	DC..1504..

Spare Parts, Parts included in delivery

Accessories*

For size	Insert key	Insert screw	Insert shim	Shim screw	Shim key
...07	T07P-2	C02506-T07P	-	-	-
..12M11/.14M11/.16H11	T15P-2	C04008-T15P	-	-	-
..20K11/.25M11	T15P-2	C03510-T15P	126.19-620	CA3510	9/64SMS875
...15	T15P-2	C04512-T15P	126.19-621	CA4508	5SMS795

Please check availability in current price and stock-list

*To be ordered separately

Toolholders for inserts DNGA, DNMA, DNMG and DNMU



- For insert programme, see page(s) 360-364, 406-407
- γ_0° = Rake angle, λ_s° = Inclination angle
- For holder code key, see page(s) 14-15

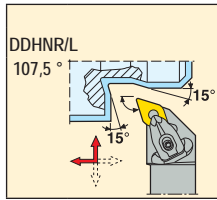
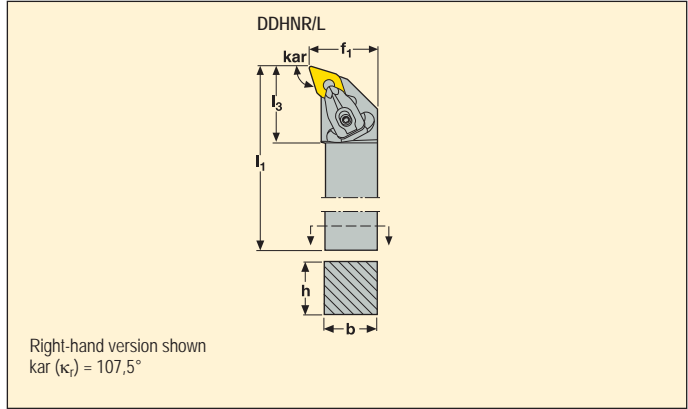

	Part No.	Dimensions in mm					γ_0°	λ_s°	KG	
		h	b	l_1	f_1	l_3				
11	DDHNR 1616H11	16	16	100	20,0	26	-6	-6	0,2	DN..1104..
	2020K11	20	20	125	25,0	26	-6	-6	0,4	DN..1104..
	2525M11	25	25	150	32,0	26	-6	-6	0,8	DN..1104..
	DDHNL 1616H11	16	16	100	20,0	26	-6	-6	0,2	DN..1104..
	2020K11	20	20	125	25,0	26	-6	-6	0,4	DN..1104..
	2525M11	25	25	150	32,0	26	-6	-6	0,8	DN..1104..
15	DDHNR 2020K15	20	20	125	25,0	32	-6	-6	0,4	DN..1506..
	2525M15	25	25	150	32,0	36	-6	-6	0,8	DN..1506..
	3225P15	32	25	170	32,0	33	-6	-6	1,1	DN..1506..
	3232P15	32	32	170	40,0	33	-6	-6	1,3	DN..1506..
	DDHNL 2020K15	20	20	125	25,0	32	-6	-6	0,4	DN..1506..
	2525M15	25	25	150	32,0	36	-6	-6	0,8	DN..1506..
	3225P15	32	25	170	32,0	33	-6	-6	1,1	DN..1506..
	3232P15	32	32	170	40,0	33	-6	-6	1,3	DN..1506..

Spare Parts, Parts included in delivery

Accessories*

For size	Clamp pin	Clamp screw	Floating wedge clamp	Insert shim	Shim/clamp key	Shim screw	Spring	Clamp kit
...11	FP1508	L84017-T09P	CD09-S	DDN110310	T09P-2	C03007-T09P	S5608	CD09-S09
...15	FP2012	L85021-T15P	CD12-S	DDN150416	T15P-7	C04008-T15P	S6912	CD12-S12

Please check availability in current price and stock-list

*To be ordered separately
Shim DDN150616 for insert DN..1504.., to be ordered separately

Toolholders for inserts DNGA, DNGG, DNGM, DNMA, DNMG, DNMM, DNMU and DNMX



- For insert programme, see page(s) 360-365, 406-407
- γ_0° = Rake angle, λ_s° = Inclination angle
- For holder code key, see page(s) 14-15

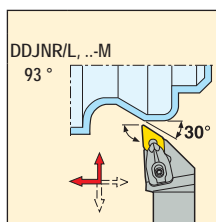
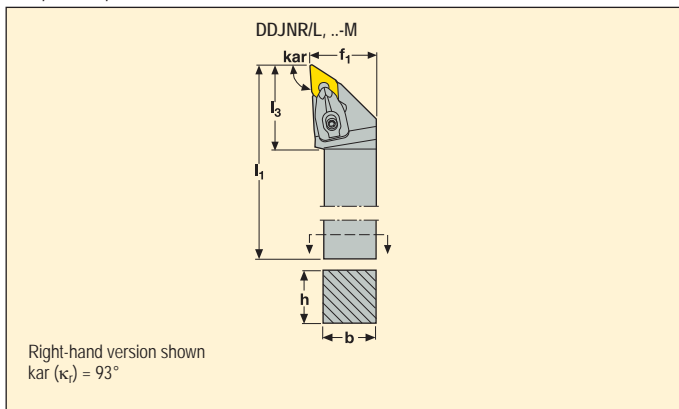

	Part No.	Dimensions in mm					γ_0°	λ_s°	KG	
		h	b	l_1	f_1	l_3				
11	DDJNR 1616H11	16	16	100	20,0	31	-6	-6	0,2	DN..1104..
	2020K11	20	20	125	25,0	31	-6	-6	0,4	DN..1104..
	2525M11	25	25	150	32,0	31	-6	-6	0,7	DN..1104..
	3225P11	32	25	170	32,0	31	-6	-6	1,1	DN..1104..
	DDJNL 1616H11	16	16	100	20,0	31	-6	-6	0,2	DN..1104..
	2020K11	20	20	125	25,0	31	-6	-6	0,4	DN..1104..
	2525M11	25	25	150	32,0	31	-6	-6	0,7	DN..1104..
	3225P11	32	25	170	32,0	31	-6	-6	1,1	DN..1104..
15	DDJNR 2020K15-M	20	20	125	25,0	42	-6	-6	0,4	DN..1506..
	2525M15-M	25	25	150	32,0	42	-6	-6	0,8	DN..1506..
	3225P15-M	32	25	170	32,0	42	-6	-6	1,1	DN..1506..
	3232P15-M	32	32	170	40,0	42	-6	-6	1,4	DN..1506..
	DDJNL 2020K15-M	20	20	125	25,0	42	-6	-6	0,4	DN..1506..
	2525M15-M	25	25	150	32,0	42	-6	-6	0,8	DN..1506..
	3225P15-M	32	25	170	32,0	42	-6	-6	1,1	DN..1506..
	3232P15-M	32	32	170	40,0	42	-6	-6	1,4	DN..1506..

Spare Parts, Parts included in delivery

For size	Clamp pin	Clamp screw	Floating wedge clamp	Insert shim	Shim/clamp key	Shim screw	Spring	Clamp kit
...								
...11	FP1508	L84017-T09P	CD09-S	DDN110310	T09P-2	C03007-T09P	S5608	CD09-S09
...15	FP2012	L85021-T15P	CD12-S	DDN150416	T15P-7	C04008-T15P	S6912	CD12-S12

Accessories*

Please check availability in current price and stock-list

*To be ordered separately
Shim DDN150616 for insert DN..1504.., to be ordered separately

Toolholders for inserts DNGA, DNGG, DNGM, DNMA, DNMG, DNMM, DNMU and DNMX



- For insert programme, see page(s) 360-365, 406
- γ_0° = Rake angle, λ_s° = Inclination angle
- For holder code key, see page(s) 14-15

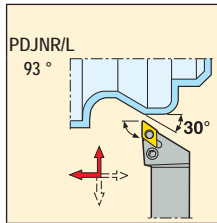
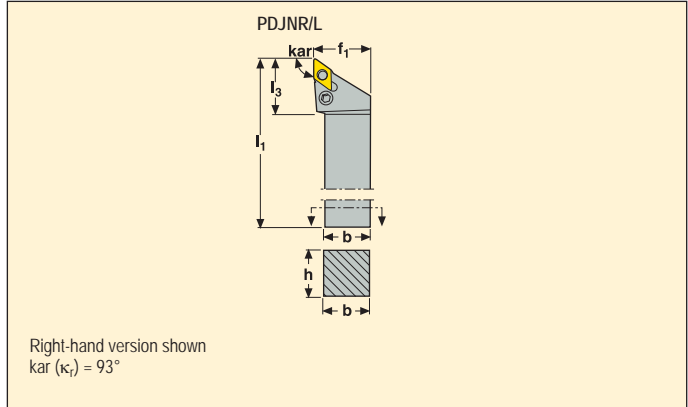

	Part No.	Dimensions in mm					γ_0°	λ_s°	KG	
		h	b	l_1	f_1	l_3				
11	PDJNR 1616H11	16	16	100	20,0	24	-6	-6	0,2	DN..1104..
	2020K11	20	20	125	25,0	30	-6	-7	0,5	DN..1104..
	2525M11	25	25	150	32,0	30	-6	-7	0,7	DN..1104..
	3225P11	32	25	170	32,0	30	-6	-7	1,0	DN..1104..
	PDJNL 1616H11	16	16	100	20,0	24	-6	-6	0,2	DN..1104..
	2020K11	20	20	125	25,0	30	-6	-7	0,5	DN..1104..
15	2525M11	25	25	150	32,0	30	-6	-7	0,7	DN..1104..
	3225P11	32	25	170	32,0	30	-6	-7	1,0	DN..1104..
	PDJNR 2020K15	20	20	125	25,0	36	-6	-7	0,4	DN..1506..
	2525M15	25	25	150	32,0	36	-6	-7	0,7	DN..1506..
	3225P15	32	25	170	32,0	36	-6	-7	1,1	DN..1506..
	PDJNL 2020K15	20	20	125	25,0	36	-6	-7	0,4	DN..1506..
	2525M15	25	25	150	32,0	36	-6	-7	0,7	DN..1506..
	3225P15	32	25	170	32,0	36	-6	-7	1,1	DN..1506..

Spare Parts, Parts included in delivery

For size	Insert lever	Insert shim	Lever key	Lever screw	Punch	Shim pin
...11	PP3512	PDN110308	2.5SMS795	LS0616	MP0912	RP5153
...15	PP4716	PDN150308	3SMS795	LS0822	MP0912	RP6757

Please check availability in current price and stock-list

Toolholders for inserts DNGA, DNGG, DNGM, DNMA, DNMG, DNMM and DNMU



- For insert programme, see page(s) 360-364, 406
- γ_0° = Rake angle, λ_s° = Inclination angle
- For holder code key, see page(s) 14-15

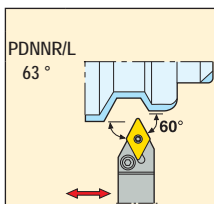
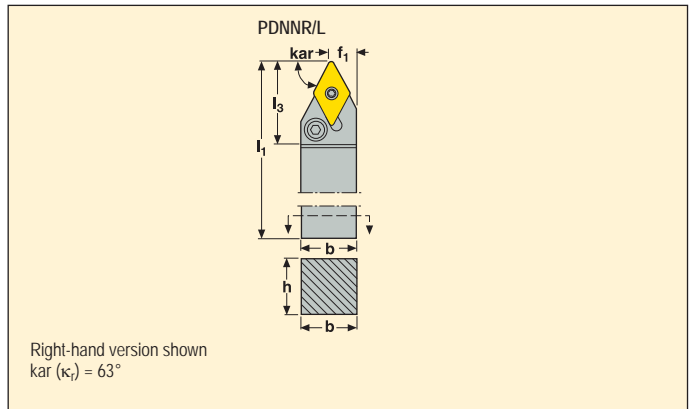

	Part No.	Dimensions in mm					γ_0°	λ_s°	KG	
		h	b	l_1	f_1	l_3				
11	PDNNR 1616H11	16	16	100	8,0	25	-6	-6	0,2	DN..1104..
	2020K11	20	20	125	10,0	25	-6	-6	0,4	DN..1104..
	2525M11	25	25	150	12,5	30	-6	-6	0,7	DN..1104..
	3225P11	32	25	170	12,5	30	-6	-6	1,0	DN..1104..
	PDNNL 1616H11	16	16	100	8,0	25	-6	-6	0,2	DN..1104..
	2020K11	20	20	125	10,0	25	-6	-6	0,4	DN..1104..
15	2525M11	25	25	150	12,5	30	-6	-6	0,7	DN..1104..
	3225P11	32	25	170	12,5	30	-6	-6	1,0	DN..1104..
	PDNNR 2020K15	20	20	125	10,0	36	-6	-6	0,4	DN..1506..
	2525M15	25	25	150	12,5	36	-6	-6	0,7	DN..1506..
	3225P15	32	25	170	12,5	36	-6	-6	1,0	DN..1506..
	PDNNL 2020K15	20	20	125	10,0	36	-6	-6	0,4	DN..1506..
	2525M15	25	25	150	12,5	36	-6	-6	0,7	DN..1506..
	3225P15	32	25	170	12,5	36	-6	-6	1,0	DN..1506..

Spare Parts, Parts included in delivery

For size	Insert lever	Insert shim	Lever key	Lever screw	Punch	Shim pin
...11	PP3512	PDN110308	2.5SMS795	LS0616	MP0912	RP5153
...15	PP4716	PDN150308	3SMS795	LS0822	MP0912	RP6757

Please check availability in current price and stock-list

Toolholders for PCBN inserts DNGN and DNMN

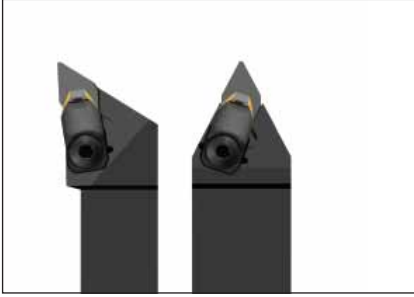

- For insert programme, see page(s) 407-408
- γ_0° = Rake angle, λ_s° = Inclination angle
- For holder code key, see page(s) 14-15

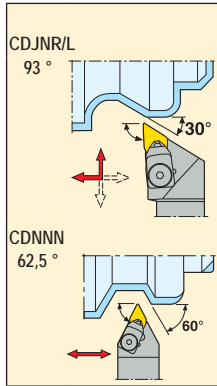
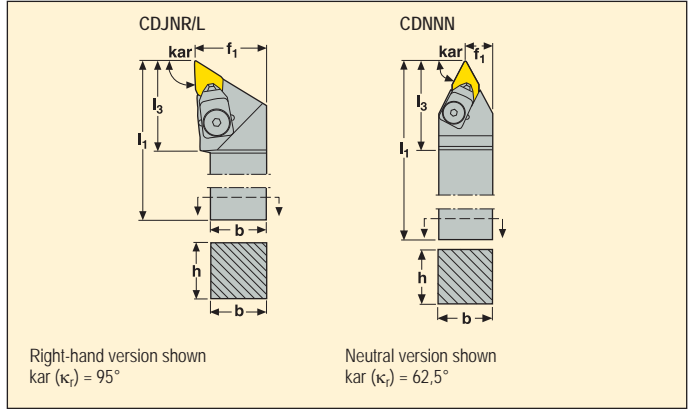

	Part No.	Dimensions in mm					γ_0°	λ_s°	KG	
		h	b	l ₁	f ₁	l ₃				
11	CDJNR 2525M11	25	25	150	32,0	34	-6	-6	0,8	DN.N1103..
	3225P11	32	25	170	32,0	34	-6	-6	1,1	DN.N1103..
	CDJNL 2525M11	25	25	150	32,0	34	-6	-6	0,8	DN.N1103..
	3225P11	32	25	170	32,0	34	-6	-6	1,1	DN.N1103..
11	CDNNN 2525M11	25	25	150	13,2	30	-9	-5	0,7	DN.N1103..
	3225P11	32	25	170	13,2	30	-9	-5	1,1	DN.N1103..

Spare Parts, Parts included in delivery

Accessories*

For size	Cantilever clamp	Clamp key	Insert shim	Pressure plate	Shim screw	Shim key
...11	 CC20P	 4SMS795	 CDN110412	 P1311-09	 174.10-652-T07P	 T07P-2

Please check availability in current price and stock-list

*To be ordered separately

Toolholders for PCBN inserts DNMA



- For insert programme, see page(s) 407
- γ_0° = Rake angle, λ_s° = Inclination angle
- For holder code key, see page(s) 14-15

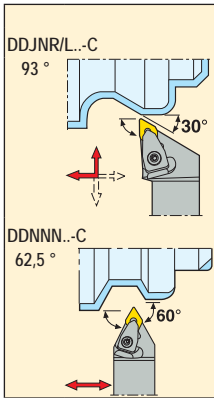
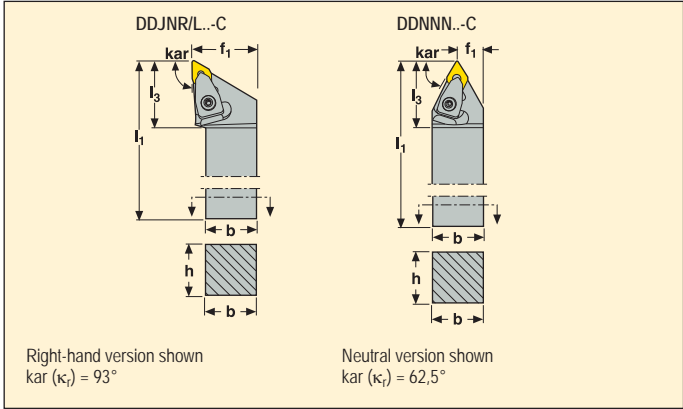

	Part No.	Dimensions in mm					γ_0°	λ_s°	KG	
		h	b	l_1	f_1	l_3				
11	DDJNR 3225P11-C	32	25	170	32,0	32	-6	-6	1,1	DNMA1104..
	DDJNL 3225P11-C	32	25	170	32,0	32	-6	-6	1,1	DNMA1104..
11	DDNNN 3225P11-C	32	25	170	32,0	33	-9	-5	1,0	DNMA1104..

Spare Parts, Parts included in delivery

Accessories*

For size	Clamp pin	Clamp screw	Floating wedge clamp	Insert shim	Shim/clamp key	Shim screw	Spring	Clamp kit
...11	FP1508	L84017-T09P	CC09P-SET	DDN110310	T09P-2	C03007-T09P	S5608	CC09P-D11

Please check availability in current price and stock-list

*To be ordered separately

Toolholders for inserts RCGS



- For insert programme, see page(s) 368, 408
- γ_0° = Rake angle, λ_s° = Inclination angle
- For holder code key, see page(s) 14-15

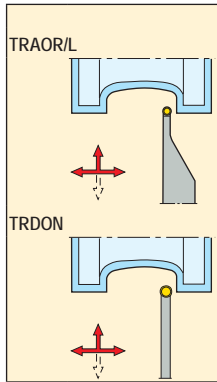
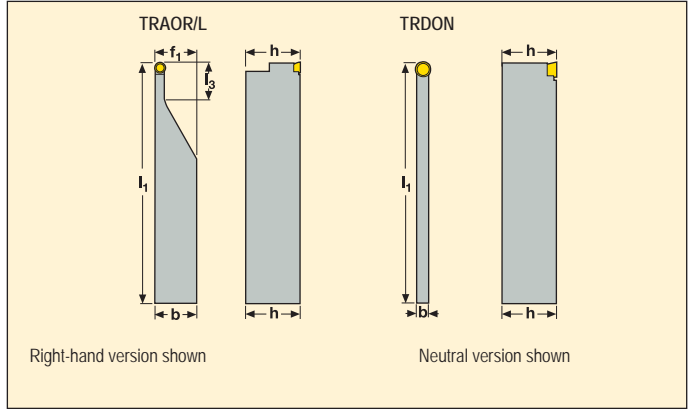

	Part No.	Dimensions in mm					γ_0°	λ_s°	KG	
		h	b	l_1	f_1	l_3				
4,76	TRAOR 3225-4.76	32	25	150	25,4	20	0	0	0,8	RCGS4.76
	TRAOL 3225-4.76	32	25	150	25,4	20	0	0	0,8	RCGS4.76
6,35	TRAOR 3225-6.35	32	25	150	25,5	20	0	0	0,8	RCGS6.35
	TRAOL 3225-6.35	32	25	150	25,5	20	0	0	0,8	RCGS6.35
9,525	TRAOR 3225-9.525	32	25	200	25,8	25	0	0	1,1	RCGS9.525
4,76	TRDON 2004H4.76	20	4	100	4,4	0	0	0	0,1	RCGS4.76
6,35	TRDON 2005H6.35	20	5	100	6,0	0	0	0	0,1	RCGS6.35

Please check availability in current price and stock-list

Toolholders for inserts RCMT



- For insert programme, see page(s) 369
- γ_0° = Rake angle, λ_s° = Inclination angle
- For holder code key, see page(s) 14-15

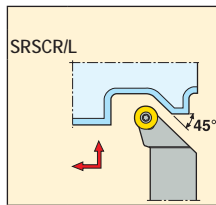
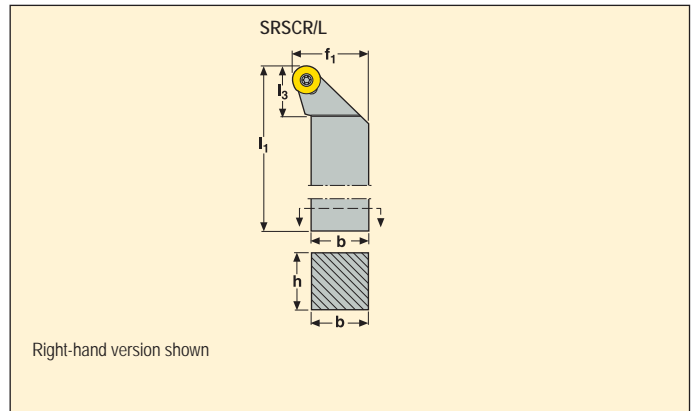

	Part No.	Dimensions in mm					γ_0°	λ_s°	KG	
		h	b	l_1	f_1	l_3				
06	SRSCR 2020K06	20	20	125	25,0	15	0	0	0,4	RCMT0602..
	2525M06	25	25	150	32,0	15	0	0	0,7	RCMT0602..
	SRSCL 2020K06	20	20	125	25,0	15	0	0	0,4	RCMT0602..
	2525M06	25	25	150	32,0	15	0	0	0,7	RCMT0602..
08	SRSCR 2020K08	20	20	125	25,0	25	0	0	0,4	RCMT0803..
	2525M08	25	25	150	32,0	25	0	0	0,7	RCMT0803..
	SRSCL 2525M08	25	25	150	32,0	25	0	0	0,7	RCMT0803..
10	SRSCR 2020K10	20	20	125	25,0	17	0	0	0,4	RCMT10T3..
	2525M10	25	25	150	32,0	20	0	0	0,7	RCMT10T3..
	SRSCL 2020K10	20	20	125	25,0	17	0	0	0,4	RCMT10T3..
	2525M10	25	25	150	32,0	20	0	0	0,7	RCMT10T3..
12	SRSCR 2525M12	25	25	150	32,0	23	0	0	0,7	RCMT1204..
	3225P12	32	25	170	32,0	23	0	0	1,1	RCMT1204..
	SRSCL 2525M12	25	25	150	32,0	23	0	0	0,7	RCMT1204..
	3225P12	32	25	170	32,0	23	0	0	1,1	RCMT1204..
16	SRSCR 3225P16	32	25	170	32,0	25	0	0	1,1	RCMT1606..
	SRSCL 3225P16	32	25	170	32,0	25	0	0	1,1	RCMT1606..

Spare Parts, Parts included in delivery

For size	Insert key	Insert screw	Insert shim	Shim screw	Shim key
...06	T07P-2	C02506-T07P	-	-	-
...08	T09P-2	C03007-T09P	-	-	-
...10	T15P-2	C03510-T15P	111.19-620	CA3510	9/64SMS875
...12	T15P-2	C03512-T15P	111.19-621	CA3510	9/64SMS875
...16	T20P-7L	C05018-T20P	SRN16T3M0	CA5015	5SMS795

Accessories*

Please check availability in current price and stock-list

*To be ordered separately

Toolholders for inserts RCMT



- For insert programme, see page(s) 369
- γ_0° = Rake angle, λ_s° = Inclination angle
- For holder code key, see page(s) 14-15

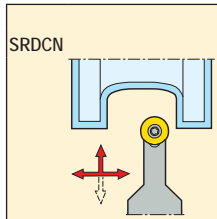
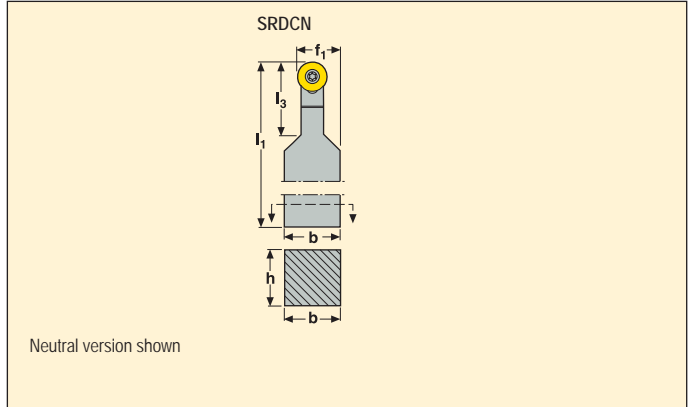

	Part No.	Dimensions in mm					γ_0°	λ_s°	KG	
		h	b	l_1	f_1	l_3				
06	SRDCN 1616H06	16	16	100	11,0	16	0	0	0,2	RCMT0602..
	2020K06	20	20	125	13,0	16	0	0	0,4	RCMT0602..
	2525M06	25	25	150	15,5	16	0	0	0,7	RCMT0602..
08	SRDCN 1616H08	16	16	100	12,0	16	0	0	0,2	RCMT0803..
	2020K08	20	20	125	14,0	20	0	0	0,4	RCMT0803..
	2525M08	25	25	150	16,5	25	0	0	0,7	RCMT0803..
10	SRDCN 2020K10	20	20	125	15,0	20	0	0	0,4	RCMT10T3..
	2525M10	25	25	150	17,5	25	0	0	0,7	RCMT10T3..
12	SRDCN 2525M12	25	25	150	18,5	25	0	0	0,7	RCMT1204..
	3225P12	32	25	170	18,5	32	0	0	1,0	RCMT1204..
16	SRDCN 3225P16	32	25	170	20,5	32	0	0	1,0	RCMT1606..

Spare Parts, Parts included in delivery

For size	Insert key	Insert screw	Insert shim	Shim screw	Shim key
...06	T07P-2	C02506-T07P	-	-	-
...08	T09P-2	C03007-T09P	-	-	-
...10	T15P-2	C03510-T15P	111.19-620	CA3510	9/64SMS875
...12	T15P-2	C03512-T15P	111.19-621	CA3510	9/64SMS875
...16	T20P-7L	C05018-T20P	SRN16T3M0	CA5015	5SMS795

Accessories*

Please check availability in current price and stock-list

*To be ordered separately

Toolholders for inserts RCMX



- For insert programme, see page(s) 370
- γ_0° = Rake angle, λ_s° = Inclination angle
- For holder code key, see page(s) 14-15

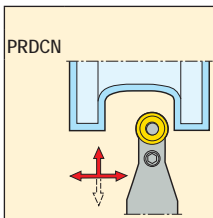
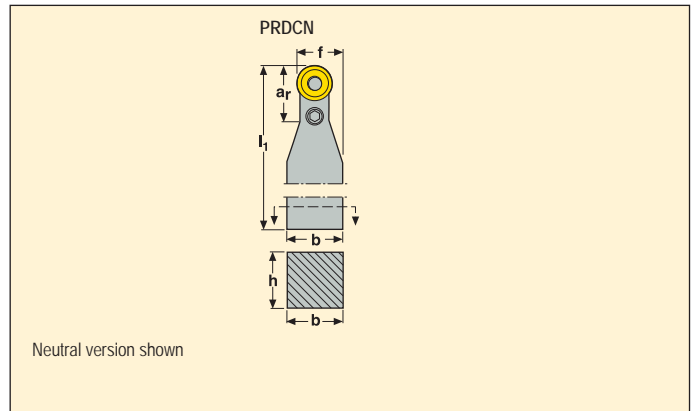

		Part No.	Dimensions in mm					γ_0°	λ_s°		KG	
			h	b	l_1	f_1	l_3					
20	PRDCN	3232P20	32	32	170	26,0	55	0	-8	1,2	RCMX200600	
25	PRDCN	4040S25	40	40	250	32,5	86	0	-8	2,8	RCMX250700	
32	PRDCN	5050T32	50	50	300	40,9	108	0	-8	5,3	RCMX320900	

Spare Parts, Parts included in delivery

For size	Insert lever	Insert shim	Lever key	Lever screw	Punch	Shim pin
...20	PP5620	PRN2004M0	3SMS795	LS0823	MP1519	RP8286
...25	PP6224	PRN2506M0	4SMS795	LS1030	MP1519	RP9811
...32	PP8030	PRN3206M0	5SMS795	LS1236	MP25	RP1312

Please check availability in current price and stock-list

Toolholders for PCBN inserts RNGN and RNMN

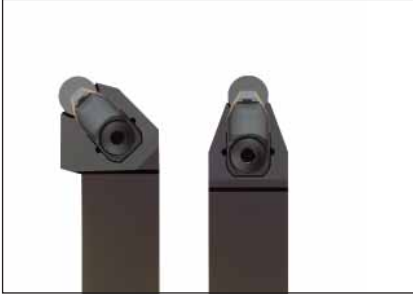

- For insert programme, see page(s) 409-411, 434, 437
- γ_0° = Rake angle, λ_s° = Inclination angle
- For holder code key, see page(s) 14-15

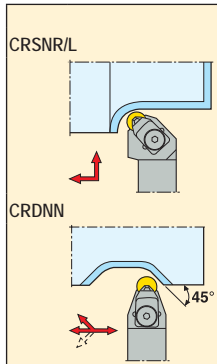
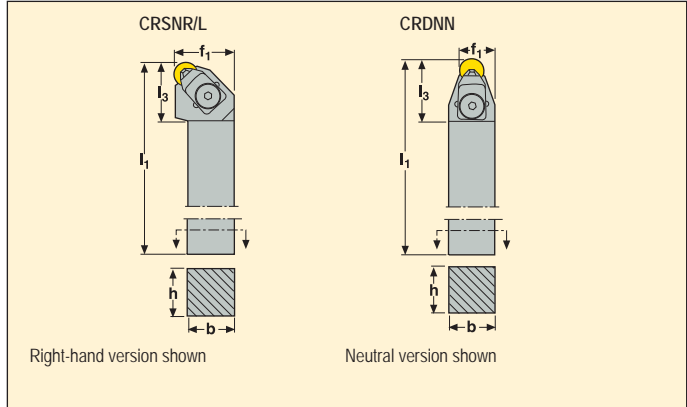

Part No.	Dimensions in mm					γ_0°	λ_s°	KG	Yellow Circle	
	h	b	l_1	f_1	l_3					
06	CRSNR 2525M06	25	25	150	32,0	27	-6	-6	0,8	RN.N0603..
	CRSNL 2525M06	25	25	150	32,0	27	-6	-6	0,8	RN.N0603..
09	CRSNR 2525M09	25	25	150	32,0	29	-6	-6	0,8	RN.N0903..
	3225P09	32	25	170	32,0	29	-6	-6	1,1	RN.N0903..
	4040R09	40	40	200	50,0	29	-6	-6	2,5	RN.N0903..
	CRSNL 2525M09	25	25	150	32,0	29	-6	-6	0,8	RN.N0903..
	3225P09	32	25	170	32,0	29	-6	-6	1,1	RN.N0903..
	4040R09	40	40	200	50,0	29	-6	-6	2,5	RN.N0903..
12	CRSNR 3225P12	32	25	170	32,0	30	-6	-6	1,1	RN.N1203..
	4040R12	40	40	200	50,0	30	-6	-6	2,5	RN.N1203..
	5040T12	50	40	300	50,0	30	-6	-6	4,7	RN.N1203..
	CRSNL 3225P12	32	25	170	32,0	30	-6	-6	1,1	RN.N1203..
	4040R12	40	40	200	50,0	30	-6	-6	2,5	RN.N1203..
06	CRDNN 2525M06	25	25	150	15,5	29	0	-8	0,7	RN.N0603..
09	CRDNN 3225P09	32	25	170	17,0	31	0	-8	1,0	RN.N0603..
	4040R09	40	40	200	24,8	31	0	-8	2,3	RN.N0903..
12	CRDNN 3225P12	32	25	170	18,5	36	0	-8	1,1	RN.N1203..
	4040R12	40	40	200	26,3	36	0	-8	2,3	RN.N1203..
	5040T12	50	40	300	26,3	36	0	-8	4,4	RN.N1203..

Spare Parts, Parts included in delivery

For size	Cantilever clamp	Clamp key	Insert shim	Pressure plate	Shim screw	Shim key
...06	CC17P-06	4SMS795	CRN0603M0	P1311-06	CS2507-T07P	T07P-2
...09	CC17P-09	4SMS795	117.10-620	P1311-09	174.10-652-T07P	T07P-2
...12	CC17P	4SMS795	117.10-622	P1311	F94009-T09P	T09P-2

Accessories*

Please check availability in current price and stock-list

*To be ordered separately

Shim 117.10-621 for insert RN.N1204.., to be ordered separately

Toolholders for inserts RNMA and RNMG

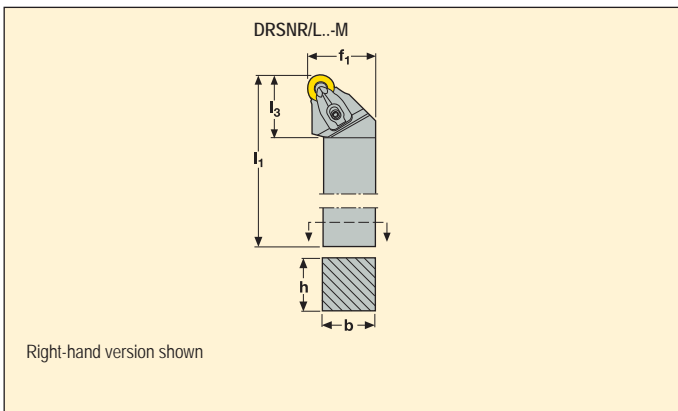

- For insert programme, see page(s) 371
- γ_0° = Rake angle, λ_s° = Inclination angle
- For holder code key, see page(s) 14-15

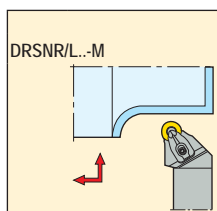

Part No.	Dimensions in mm					γ_0°	λ_s°	KG		
	h	b	l_1	f_1	l_3					
12	DRSNR 2525M12-M	25	25	150	32,0	30	-6	-6	0,8	RN..120400
	3225P12-M	32	25	170	32,0	30	-6	-6	1,1	RN..120400
	DRSNL 2525M12-M	25	25	150	32,0	30	-6	-6	0,8	RN..120400
	3225P12-M	32	25	170	32,0	30	-6	-6	1,1	RN..120400

Spare Parts, Parts included in delivery

Accessories*

For size	Clamp pin	Clamp screw	Floating wedge clamp	Insert shim	Shim/clamp key	Shim screw	Spring	Clamp kit
...12	FP2012	L85021-T15P	CD12-S	DRN120600	T15P-7	C04008-T15P	S6912	CD12-S12

Please check availability in current price and stock-list

*To be ordered separately

Toolholders for inserts SCGW, SCMT and SCMW



- For insert programme, see page(s) 372, 412
- γ_0° = Rake angle, λ_s° = Inclination angle
- For holder code key, see page(s) 14-15

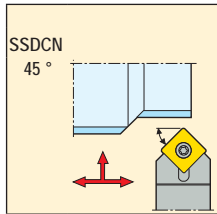
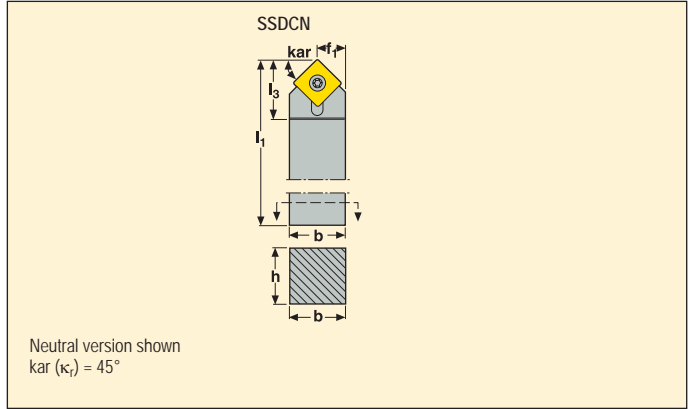

	Part No.	Dimensions in mm					γ_0°	λ_s°	KG	Key
		h	b	l_1	f_1	l_3				
09	SSDCN 1212M09	12	12	150	6,2	23	0	0	0,2	SC..09T3..
	1616H09	16	16	100	8,2	26	0	0	0,2	SC..09T3..
	2020K09	20	20	125	10,2	22	0	0	0,4	SC..09T3..
	2525M09	25	25	150	12,7	23	0	0	0,8	SC..09T3..
12	SSDCN 2020K12	20	20	125	10,2	22	0	0	0,4	SC..1204..
12	SSDCN 2525M12	25	25	150	12,7	22	0	0	0,8	SC..1204..

Spare Parts, Parts included in delivery

For size	Insert key	Insert screw	Insert shim	Shim screw	Shim key
...09	T15P-2	C04008-T15P	-	-	-
...K12	T15P-2	C05012-T15P	110.19-621	CA5008	5SMS795
...M12	T20P-7L	C05018-T20P	110.19-621	CA5015	5SMS795

Accessories*

Please check availability in current price and stock-list

*To be ordered separately

Toolholders for PCBN inserts SNGN, SNMN and SNUN

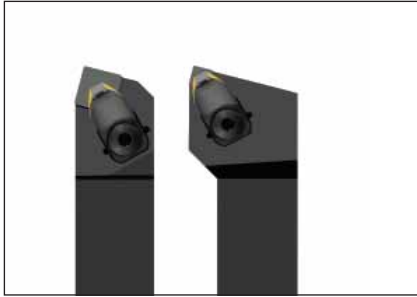

- For insert programme, see page(s) 414-415
- γ_0° = Rake angle, λ_s° = Inclination angle
- For holder code key, see page(s) 14-15

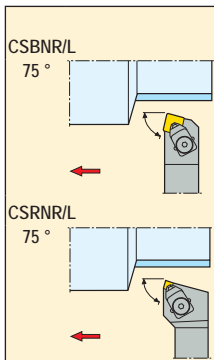
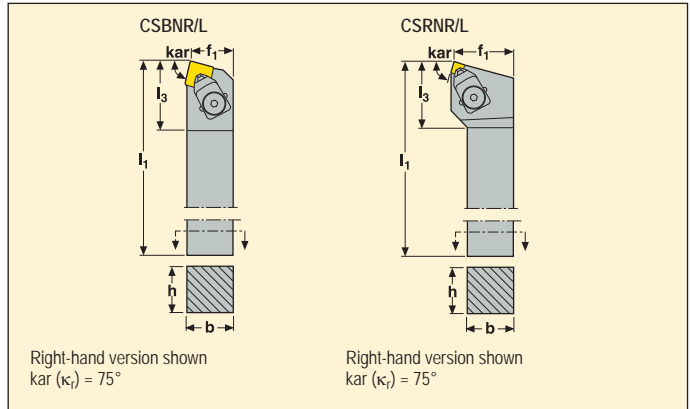

	Part No.	Dimensions in mm					γ_0°	λ_s°	KG	
		h	b	l_1	f_1	l_3				
09	CSBNR 2525M09	25	25	150	22,0	30	-6	-6	0,8	SN.N0903..
	3225P09	32	25	170	22,0	30	-6	-6	1,1	SN.N0903..
	CSBNL 2525M09	25	25	150	22,0	30	-6	-6	0,8	SN.N0903..
12	CSBNR 3225P12	32	25	170	22,0	35	-6	-6	1,1	SN.N1204..
	CSBNL 3225P12	32	25	170	22,0	35	-6	-6	1,1	SN.N1204..
06	CSRNR 2525M06	25	25	150	32,0	35	-6	-6	0,8	SN.N0603..
	CSRNL 2525M06	25	25	150	32,0	30	-6	-6	0,8	SN.N0603..
12	CSRNR 4040R12	40	40	200	43,2	37	-6	-6	2,5	SN.N1204..
	CSRNL 4040R12	40	40	200	43,2	37	-6	-6	2,5	SN.N1204..

Spare Parts, Parts included in delivery

For size	Cantilever clamp	Clamp key	Insert shim	Pressure plate	Shim screw
...06	CC17P-06	4SMS795	CSN060308	P1311-06	CS2507-T07P
...09	CC17P-09	4SMS795	CSN090412	P1311-09	174.10-652-T07P
...P12	CC20P	4SMS795	174.10-621	P1311	F94009-T09P
...R12	CC20P	4SMS795	174.10-621	P1311	F94009-T09P

Accessories*

Insert shim	Shim key
–	T07P-2
–	T07P-2
–	T09P-2
117.10-621	T09P-2

Please check availability in current price and stock-list

*To be ordered separately
Shim 174.10-622 for insert SN.N1203.., to be ordered separately

Toolholders for PCBN inserts SNGN, SNMN and SNUN

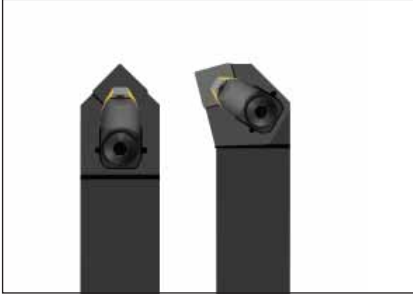

- For insert programme, see page(s) 414-415, 417
- γ_0° = Rake angle, λ_s° = Inclination angle
- For holder code key, see page(s) 14-15

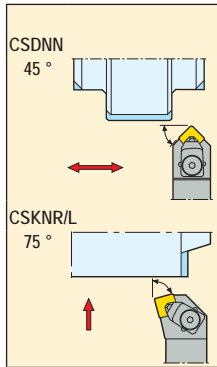
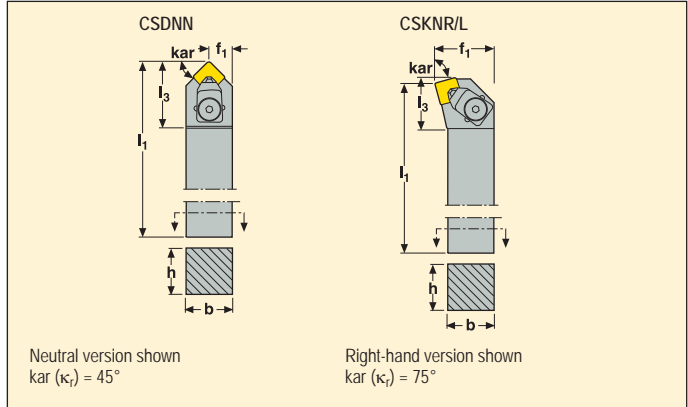

Part No.	Dimensions in mm					γ_0°	λ_s°	KG	Key
	h	b	l_1	f_1	l_3				
09 CSDNN 3225P09	32	25	170	13,0	33	-6	-6	1,1	SN.N0903..
12 CSDNN 3225P12	32	25	170	13,0	40	-6	-6	1,1	SN.N1204..
	40	40	200	20,3	40	-6	-6	2,4	SN.N1204..
06 CSKNR 2525M06	25	25	150	32,0	35	-6	-6	0,8	SN.N0603..
	25	25	150	32,0	35	-6	-6	0,8	SN.N0603..
12 CSKNR 3225P12	32	25	170	32,0	36	-6	-6	1,2	SN.N1204..
	40	40	200	50,0	36	-6	-6	2,5	SN.N1204..
	32	25	170	32,0	36	-6	-6	1,2	SN.N1204..

Spare Parts, Parts included in delivery

For size	Cantilever clamp	Clamp key	Insert shim	Pressure plate	Shim screw	Shim key
...06	CC17P-06	4SMS795	CSN060308	P1311-06	CS2507-T07P	T07P-2
...09	CC17P-09	4SMS795	CSN090412	P1311-09	174.10-652-T07P	T07P-2
...12	CC20P	4SMS795	174.10-621	P1311	F94009-T09P	T09P-2

Accessories*

Please check availability in current price and stock-list

*To be ordered separately
Shim 174.10-622 for insert SN.N1203.., to be ordered separately

Toolholders for PCBN inserts SNGN and SNMN



- For insert programme, see page(s) 415, 417
- γ_0° = Rake angle, λ_s° = Inclination angle
- For holder code key, see page(s) 14-15

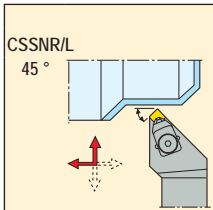
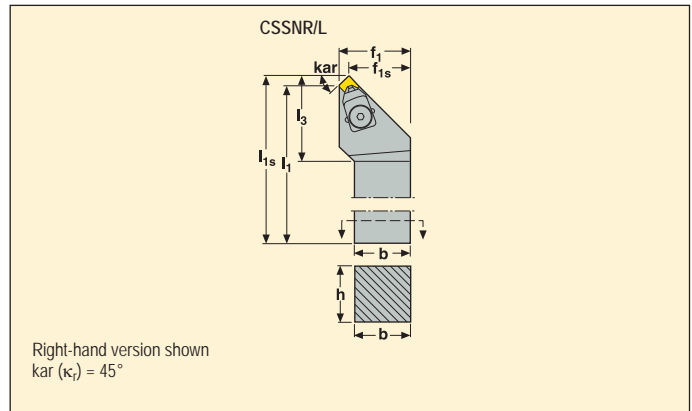

	Part No.	Dimensions in mm							γ_0°	λ_s°	KG	
		h	b	l_1	l_{1s}	f_1	f_{1s}	l_3				
06	CSSNR 2525M06	25	25	150	154	32,2	27,8	27	-7	0	0,8	SN.N0603..
	CSSNL 2525M06	25	25	150	154	32,2	27,8	27	-7	0	0,8	SN.N0603..

Spare Parts, Parts included in delivery

Accessories*

For size	Cantilever clamp	Clamp key	Insert shim	Pressure plate	Shim screw	Shim key
...06	CC17P-06	4SMS795	CSN060308	P1311-06	CS2507-T07P	T07P-2

Please check availability in current price and stock-list

*To be ordered separately

Toolholders for inserts SNGA, SNMA, SNMG and SNMM



- For insert programme, see page(s) 374-378, 413
- γ_0° = Rake angle, λ_s° = Inclination angle
- For holder code key, see page(s) 14-15

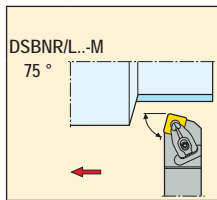
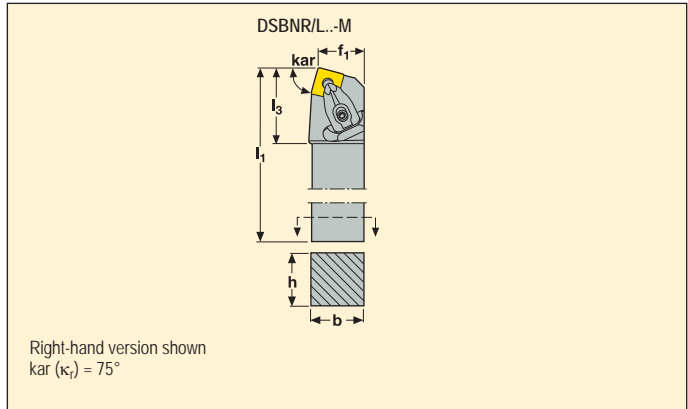

	Part No.	Dimensions in mm					γ_0°	λ_s°	KG	□
		h	b	l_1	f_1	l_3				
12	DSBNR 2020K12-M	20	20	125	17,0	37	-6	-6	0,5	SN..1204..
	2525M12-M	25	25	150	22,0	36	-6	-6	0,8	SN..1204..
	DSBNL 2020K12-M	20	20	125	17,0	37	-6	-6	0,5	SN..1204..
	2525M12-M	25	25	150	22,0	36	-6	-6	0,8	SN..1204..
15	DSBNR 2525M15-M	25	25	150	22,0	41	-6	-6	0,8	SN..1506..
	3225P15-M	32	25	170	22,0	42	-6	-6	1,1	SN..1506..
	3232P15-M	32	32	170	27,0	42	-6	-6	1,4	SN..1506..
	DSBNL 2525M15-M	25	25	150	22,0	41	-6	-6	0,8	SN..1506..
	3225P15-M	32	25	170	22,0	42	-6	-6	1,1	SN..1506..
	3232P15-M	32	32	170	27,0	42	-6	-6	1,4	SN..1506..

Spare Parts, Parts included in delivery

Accessories*

For size	Clamp pin	Clamp screw	Floating wedge clamp	Insert shim	Shim/clamp key	Shim screw	Spring	Clamp kit
...12	FP2012	L85021-T15P	CD12-S	DSN120616	T15P-7	C04008-T15P	S6912	CD12-S12
...15	FP2012	L86026-T20P	CD16-S	DSN150624	T20P-7L	C05010-T20P	S7010	CD16-S16

Please check availability in current price and stock-list

*To be ordered separately
Shim DSN120416 for insert SN..1206.., to be ordered separately

Toolholders for inserts SNGA, SNMA, SNMG and SNMM



- For insert programme, see page(s) 374-378, 413
- γ_0° = Rake angle, λ_s° = Inclination angle
- For holder code key, see page(s) 14-15

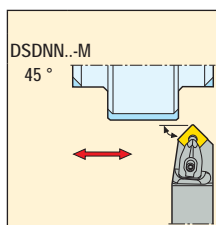
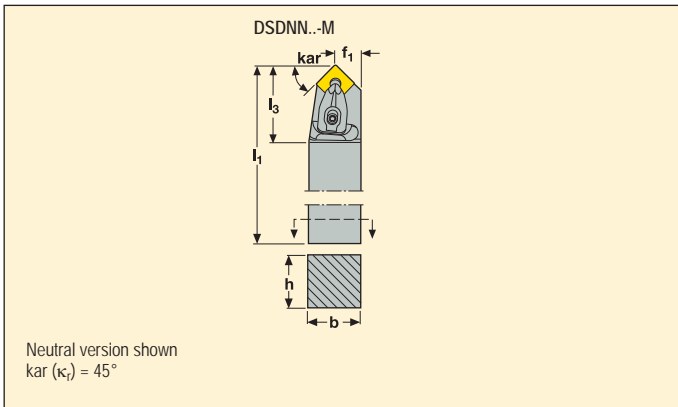

Part No.	Dimensions in mm					γ_0°	λ_s°	KG	
	h	b	l_1	f_1	l_3				
DSDNN 2020K12-M	20	20	125	10,3	37	-6	-6	0,4	SN..1204..
2525M12-M	25	25	150	12,8	36	-6	-6	0,7	SN..1204..
3232P12-M	32	32	170	16,3	36	-6	-6	1,3	SN..1204..

Spare Parts, Parts included in delivery

For size	Clamp pin	Clamp screw	Floating wedge clamp	Insert shim	Shim/clamp key	Shim screw	Spring
...12	FP2012	L85021-T15P	CD12-S	DSN120616	T15P-7	C04008-T15P	S6912

Accessories*

Clamp kit
CD12-S12

Please check availability in current price and stock-list

*To be ordered separately
Shim DSN120416 for insert SN..1206... to be ordered separately

Toolholders for inserts SNGA, SNMA, SNMG and SNMM



- For insert programme, see page(s) 374-378, 413
- γ_0° = Rake angle, λ_s° = Inclination angle
- For holder code key, see page(s) 14-15

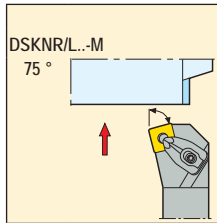
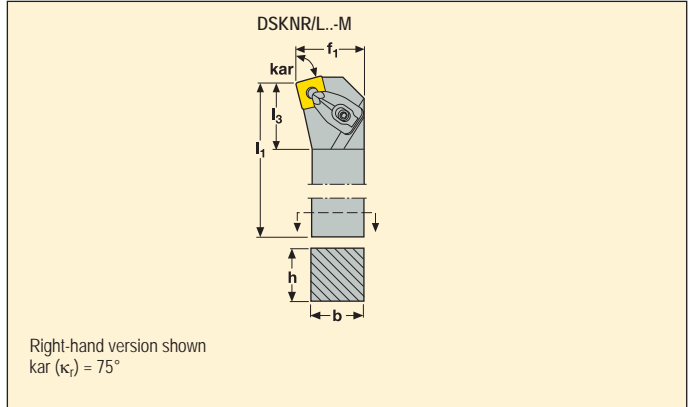

	Part No.	Dimensions in mm					γ_0°	λ_s°	KG	
		h	b	l_1	f_1	l_3				
12	DSKNR 2020K12-M	20	20	125	25,0	33	-6	-6	0,5	SN..1204..
	2525M12-M	25	25	150	32,0	33	-6	-6	0,8	SN..1204..
	3225P12-M	32	25	170	32,0	35	-6	-6	1,1	SN..1204..
	DSKNL 2020K12-M	20	20	125	25,0	33	-6	-6	0,5	SN..1204..
	2525M12-M	25	25	150	32,0	33	-6	-6	0,8	SN..1204..
	3225P12-M	32	25	170	32,0	35	-6	-6	1,1	SN..1204..
19	DSKNR 3232P19-M	32	32	170	40,0	37	-6	-6	1,5	SN..1906..
	DSKNL 3232P19-M	32	32	170	40,0	37	-6	-6	1,5	SN..1906..

Spare Parts, Parts included in delivery

Accessories*

For size	Clamp pin	Clamp screw	Floating wedge clamp	Insert shim	Shim/clamp key	Shim screw	Spring	Clamp kit
...12	FP2012	L85021-T15P	CD12-S	DSN120616	T15P-7	C04008-T15P	S6912	CD12-S12
...19	FP2012	L86026-T20P	CD19-S	DSN190624	T20P-7L	C05010-T20P	S7010	CD19-S19

Please check availability in current price and stock-list

*To be ordered separately
 Shim DSN120416 for insert SN..1206.., to be ordered separately
 Shim DSN190640 for insert SNMM190624W-R7, to be ordered separately

Toolholders for inserts SNGA, SNMA, SNMG and SNMM



- For insert programme, see page(s) 374-378, 413
- γ_0° = Rake angle, λ_s° = Inclination angle
- For holder code key, see page(s) 14-15

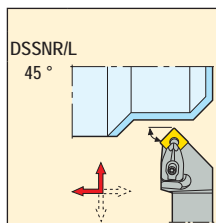
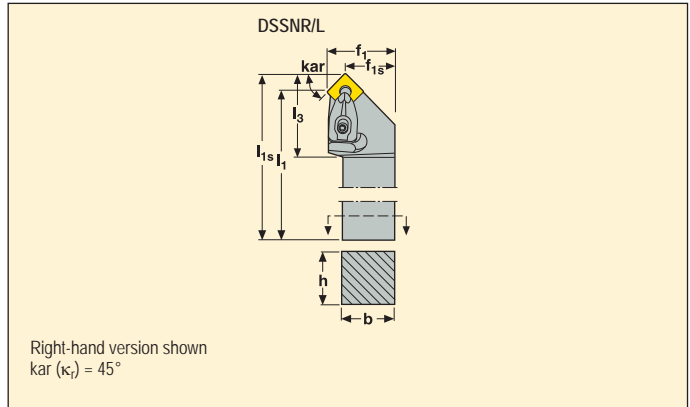

	Part No.	Dimensions in mm							γ_0°	λ_s°	KG	
		h	b	l_1	l_{1s}	f_1	f_{1s}	l_3				
09	DSSNR 1616H09-M	16	16	101	107,1	20,0	14,1	32	-8	0	0,3	SN..0903..
	2020K09-M	20	20	125	132,1	25,0	19,1	32	-8	0	0,5	SN..0903..
	2525M09-M	25	25	150	157,1	32,0	26,1	32	-8	0	0,8	SN..0903..
	DSSNL 1616H09-M	16	16	101	107,1	20,0	14,1	32	-8	0	0,3	SN..0903..
	2020K09-M	20	20	125	132,1	25,0	19,1	32	-8	0	0,5	SN..0903..
	2525M09-M	25	25	150	157,1	32,0	26,1	32	-8	0	0,8	SN..0903..
12	DSSNR 2020K12-M	20	20	125	134,3	200,0	16,9	39	-8	0	0,5	SN..1204..
	2525M12-M	25	25	150	159,3	32,0	23,9	39	-8	0	0,8	SN..1204..
	3225P12-M	32	25	170	179,3	32,0	23,9	39	-8	0	1,2	SN..1204..
	DSSNL 2020K12-M	20	20	125	134,3	25,0	16,9	39	-8	0	0,5	SN..1204..
	2525M12-M	25	25	150	159,3	32,0	23,9	39	-8	0	0,8	SN..1204..
	3225P12-M	32	25	170	179,3	32,0	23,9	39	-8	0	1,2	SN..1204..

Spare Parts, Parts included in delivery

Accessories*

For size	Clamp pin	Clamp screw	Floating wedge clamp	Insert shim	Shim/clamp key	Shim screw	Spring	Clamp kit
...09	FP1508	L84017-T09P	CD09-S	DSN090310	T09P-2	C03007-T09P	S5608	CD09-S09
...12	FP2012	L85021-T15P	CD12-S	DSN120616	T15P-7	C04008-T15P	S6912	CD12-S12

Please check availability in current price and stock-list

*To be ordered separately
Shim DSN120416 for insert SN..1206... to be ordered separately

Toolholders for inserts SNMA, SNMG and SNMM



- For insert programme, see page(s) 374-378
- γ_0° = Rake angle, λ_{s° = Inclination angle
- For holder code key, see page(s) 14-15

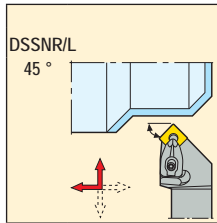
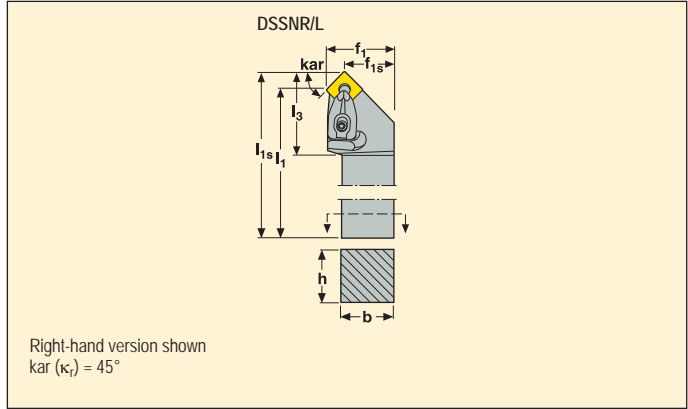

	Part No.	Dimensions in mm							γ_0°	λ_{s°	KG	
		h	b	l_1	l_{1s}	f_1	f_{1s}	l_3				
15	DSSNR 2525M15-M	25	25	150	161,2	32,0	22,0	41	-8	0	0,9	SN..1506..
	3225P15-M	32	25	170	181,2	32,0	22,0	42	-8	0	1,2	SN..1506..
	3232P15-M	32	32	171	-	40,0	-	42	-8	0	1,5	SN..1506..
	DSSNL 2525M15-M	25	25	150	161,2	32,0	22,0	41	-8	0	0,9	SN..1506..
	3225P15-M	32	25	170	181,2	32,0	22,0	42	-8	0	1,2	SN..1506..
	3232P15-M	32	32	171	-	40,0	-	42	-8	0	1,5	SN..1506..
19	DSSNR 3232P19-M	32	32	171	-	40,0	-	46	-8	0	1,5	SN..1906..
	4040R19-M	40	40	201	-	50,0	-	46	-8	0	2,6	SN..1906..
	DSSNL 3232P19-M	32	32	171	-	40,0	-	46	-8	0	1,5	SN..1906..
	4040R19-M	40	40	201	-	50,0	-	46	-8	0	2,6	SN..1906..

Spare Parts, Parts included in delivery

Accessories*

For size	Clamp pin	Clamp screw	Floating wedge clamp	Insert shim	Shim/clamp key	Shim screw	Spring	Clamp kit
...15	FP2012	L86026-T20P	CD16-S	DSN150624	T20P-7L	C05010-T20P	S7010	CD16-S16
...19	FP2012	L86026-T20P	CD19-S	DSN190624	T20P-7L	C05010-T20P	S7010	CD19-S19

Please check availability in current price and stock-list

*To be ordered separately
Shim DSN190640 for insert SNMM190624W-R7... to be ordered separately

Toolholders for inserts SNGA, SNMA, SNMG and SNMM



- For insert programme, see page(s) 374-378, 413
- γ_0° = Rake angle, λ_s° = Inclination angle
- For holder code key, see page(s) 14-15

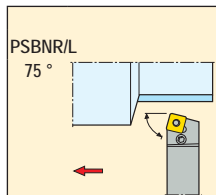
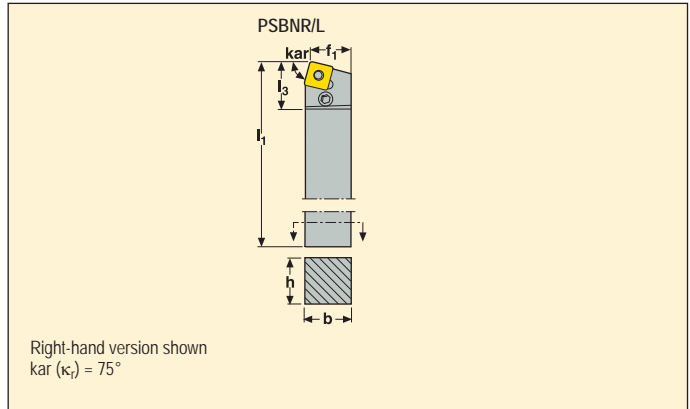

	Part No.	Dimensions in mm					γ_0°	λ_s°	KG	
		h	b	l_1	f_1	l_3				
12	PSB NR 2020K12	20	20	125	20,3	26	-6	-6	0,4	SN..1204..
	2525M12	25	25	150	25,3	26	-6	-6	0,8	SN..1204..
	3225P12	32	25	170	25,3	26	-6	-6	1,1	SN..1204..
	PSB NL 2020K12	20	20	125	20,3	26	-6	-6	0,4	SN..1204..
	2525M12	25	25	150	25,3	26	-6	-6	0,8	SN..1204..
	3225P12	32	25	170	25,3	26	-6	-6	1,1	SN..1204..
15	PSB NR 2525M15	25	25	150	22,2	34	-6	-6,0	0,7	SN..1506..
	3232P15	32	32	170	27,2	34	-6	-6,0	1,3	SN..1506..
	PSB NL 2525M15	25	25	150	22,2	34	-6	-6,0	0,7	SN..1506..
	3232P15	32	32	170	27,2	34	-6	-6,0	1,3	SN..1506..
19	PSB NR 3232P19	32	32	170	27,2	37	-6	-6,0	1,3	SN..1906..
	4040S19	40	40	250	35,2	38	-6	-6,0	3,0	SN..1906..
	PSB NL 3232P19	32	32	170	27,2	37	-6	-6,0	1,5	SN..1906..
	4040S19	40	40	250	35,2	38	-6	-6,0	3,0	SN..1906..
25	PSB NR 4040S25	40	40	250	35,2	48	-6	-6	3,1	SN..2507..
	5050S25	50	50	250	43,2	48	-6	-6	4,7	SN..2507..
	PSB NL 4040S25	40	40	250	35,2	48	-6	-6	3,1	SN..2507..
	5050S25	50	50	250	43,2	48	-6	-6	4,7	SN..2507..
	PSB NR 4040S2509	40	40	250	35,2	48	-6	-6	3,0	SN..2509..
	5050T2509	50	50	300	43,2	48	-6	-6	5,7	SN..2509..

Spare Parts, Parts included in delivery

For size	Insert lever	Insert shim	Lever key	Lever screw	Punch	Shim pin
...12	PP4713	PSN120312	3SMS795	LS0818	MP0912	RP6757
...15	PP6017	PSN150412	3SMS795	LS0820	MP1519	RP8286
...19	PP7521	PSN190412	4SMS795	LS1027	MP1519	RP9811
...25	PP1325	PSN250624	5SMS795	LS1236	MP25	RP1312
...2509	PP1325	PSN250624	5SMS795	LS1236	MP25	RP1312

Please check availability in current price and stock-list

Toolholders for inserts SNGA, SNMA, SNMG and SNMM

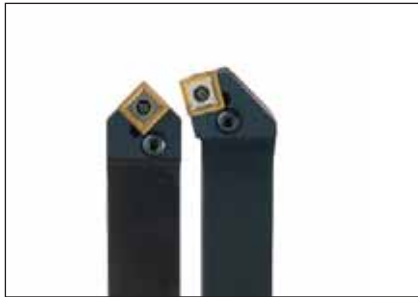

- For insert programme, see page(s) 374-378, 413
- γ_0° = Rake angle, λ_s° = Inclination angle
- For holder code key, see page(s) 14-15

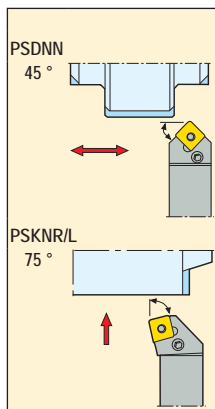
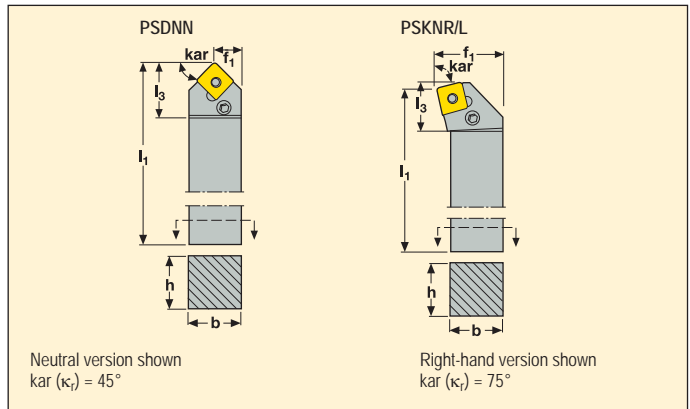

	Part No.	Dimensions in mm					γ_0°	λ_s°	KG	
		h	b	l_1	f_1	l_3				
12	PSDNN 2020K12	20	20	125	10,0	26	-7	-7	0,4	SN..1204..
	2525M12	25	25	150	12,5	26	-7	-7	0,7	SN..1204..
	3225P12	32	25	170	12,5	28	-7	-7	1,0	SN..1204..
19	PSDNN 3232P19	32	32	170	16,3	40	-6	-6	1,3	SN..1906..
25	PSDNN 4040S25	40	40	250	20,2	48	-6	-6	3,0	SN..2507..
	4040T25	40	40	300	20,2	48	-6	-6	3,6	SN..2507..
12	PSKNR 2020K12	20	20	125	25,0	23	-6	-6	0,4	SN..1204..
	2525M12	25	25	150	32,0	23	-6	-6	0,8	SN..1204..
	3225P12	32	25	170	32,0	26	-6	-6	1,1	SN..1204..
	PSKNL 2020K12	20	20	125	25,0	23	-6	-6	0,4	SN..1204..
	2525M12	25	25	150	32,0	23	-6	-6	0,8	SN..1204..
	3225P12	32	25	170	32,0	26	-6	-6	1,1	SN..1204..

Spare Parts, Parts included in delivery

For size	Insert lever	Insert shim	Lever key	Lever screw	Punch	Shim pin
...12	PP4713	PSN120312	3SMS795	LS0818	MP0912	RP6757
...19	PP7521	PSN190412	4SMS795	LS1027	MP1519	RP9811
...25	PP1325	PSN250624	5SMS795	LS1236	MP25	RP1312

Please check availability in current price and stock-list

Toolholders for PCBN inserts SNMA



- For insert programme, see page(s) 416
- γ_0° = Rake angle, λ_s° = Inclination angle
- For holder code key, see page(s) 14-15

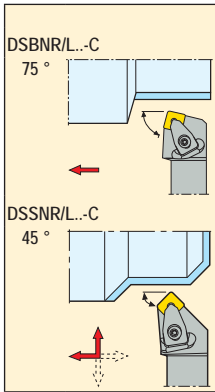
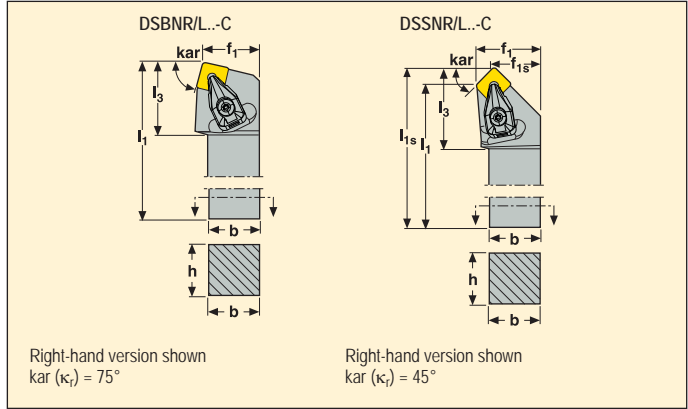

Part No.	Dimensions in mm								γ_0°	λ_s°	KG	Key
	h	b	l_1	l_{1s}	f_1	f_{1s}	l_3					
12 DSB NR 3225P12-C	32	25	170	–	32,0	–	35	–6	–6	1,1	SN.A1204..	
DSB NL 3225P12-C	32	25	170	–	32,0	–	35	–6	–6	1,1	SN.A1204..	
12 DSS NR 3225P12-C	32	25	170	179,1	32,0	23,9	39	–8	0	1,1	SN.A1204..	
DSS NL 3225P12-C	32	25	170	179,1	32,0	23,9	39	–8	0	1,1	SN.A1204..	

Spare Parts, Parts included in delivery

Accessories*

For size	Clamp pin	Clamp screw	Floating wedge clamp	Insert shim	Shim/clamp key	Shim screw	Spring	Clamp kit
...12	FP2012	L85021-T15P	CC12P-SET	DSN120616	T15P-2	C04008-T15P	S6912	CC12P-S12

Please check availability in current price and stock-list

*To be ordered separately

Toolholders for inserts TCGT, TCGW, TCMT and TCMW



- For insert programme, see page(s) 380-383, 419, 434
- γ_0° = Rake angle, λ_s° = Inclination angle
- For holder code key, see page(s) 14-15

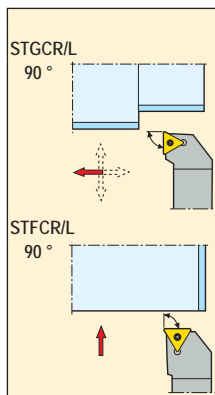
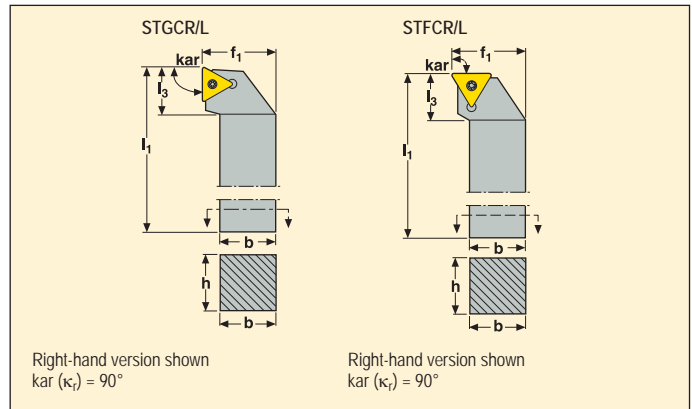

	Part No.	Dimensions in mm					γ_0°	λ_s°	KG	
		h	b	l_1	f_1	l_3				
11	STGCR 1212F11	12	12	80	16,0	17	0	0	0,1	TC..1102..
	1616H11	16	16	100	20,0	17	0	0	0,2	TC..1102..
	STGCL 1212F11	12	12	80	16,0	17	0	0	0,1	TC..1102..
	1616H11	16	16	100	20,0	17	0	0	0,2	TC..1102..
16	STGCR 1616H16	16	16	100	20,0	25	0	0	0,2	TC..16T3..
	2020K16	20	20	125	25,0	26	0	0	0,4	TC..16T3..
	2525M16	25	25	150	32,0	27	0	0	0,8	TC..16T3..
	STGCL 1616H16	16	16	100	20,0	25	0	0	0,2	TC..16T3..
	2020K16	20	20	125	25,0	26	0	0	0,4	TC..16T3..
	2525M16	25	25	150	32,0	27	0	0	0,8	TC..16T3..
11	STFCR 1212F11	12	12	80	16,0	16	0	0	0,1	TC..1102..
	1616H11	16	16	100	20,0	16	0	0	0,2	TC..1102..
	STFCL 1212F11	12	12	80	16,0	16	0	0	0,1	TC..1102..
	1616H11	16	16	100	20,0	16	0	0	0,2	TC..1102..
16	STFCR 1616H16	16	16	100	20,0	22	0	0	0,3	TC..16T3..
	2020K16	20	20	125	25,0	22	0	0	0,4	TC..16T3..
	2525M16	25	25	150	32,0	24	0	0	0,8	TC..16T3..
	STFCL 1616H16	16	16	100	20,0	22	0	0	0,3	TC..16T3..
	2020K16	20	20	125	25,0	22	0	0	0,4	TC..16T3..
	2525M16	25	25	150	32,0	24	0	0	0,8	TC..16T3..

Spare Parts, Parts included in delivery

For size	Insert key	Insert screw	Insert shim	Shim screw	Shim key
...11	T07P-2	C02506-T07P	-	-	-
...16	T15P-2	C03509-T15P	STN160312	CA3510	9/64SMS875

Accessories, to be ordered separately

Please check availability in current price and stock-list

Toolholders for inserts TCGT, TCGW, TCMT and TCMW



- For insert programme, see page(s) 380-382, 419, 434
- γ_0° = Rake angle, λ_s° = Inclination angle
- For holder code key, see page(s) 14-15

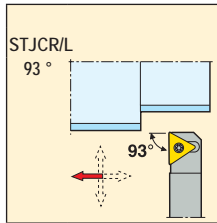
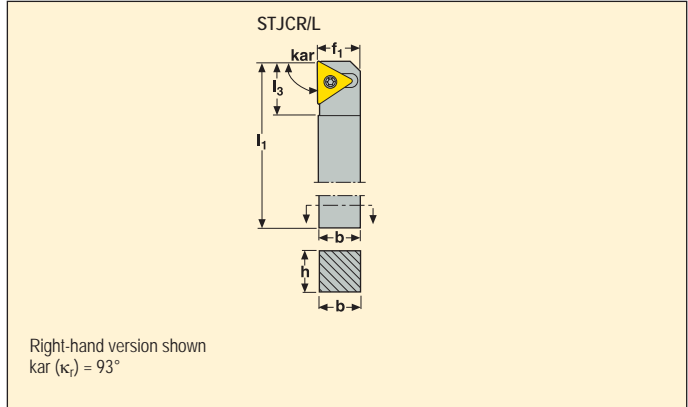

Part No.	Dimensions in mm					γ_0°	λ_s°	KG		
	h	b	l ₁	f ₁	l ₃					
11	STJCR 1010M11	10	10	150	10,0	13	0	0	0,2	TC..1102..
	1212M11	12	12	150	12,0	13	0	0	0,2	TC..1102..
	1616H11	16	16	100	16,0	13	0	0	0,2	TC..1102..
	STJCL 1010M11	10	10	150	10,0	13	0	0	0,2	TC..1102..
	1212M11	12	12	150	12,0	13	0	0	0,2	TC..1102..
	1616H11	16	16	100	16,0	13	0	0	0,2	TC..1102..

Spare Parts, Parts included in delivery

For size	Insert key	Insert screw
...11	T07P-2	C02506-T07P

Please check availability in current price and stock-list

Toolholders for inserts TNGA, TNMA, TNMG and TNMM



- For insert programme, see page(s) 385-389, 420
- γ_0° = Rake angle, λ_s° = Inclination angle
- For holder code key, see page(s) 14-15

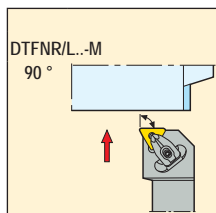
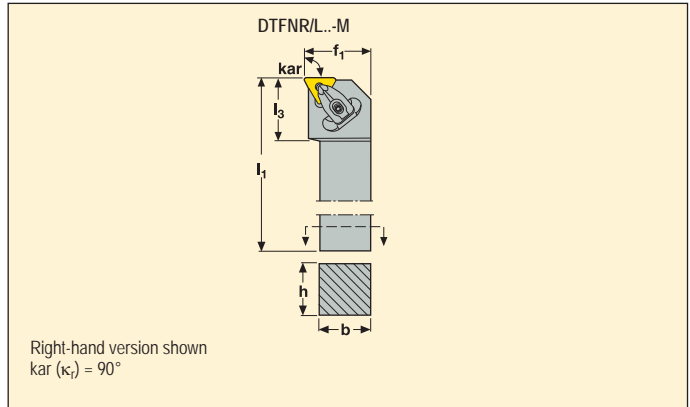

	Part No.	Dimensions in mm					γ_0°	λ_s°	KG	
		h	b	l_1	f_1	l_3				
16	DTFNR 2020K16-M	20	20	125	25,0	29	-6	-6	0,4	TN..1604..
	2525M16-M	25	25	150	32,0	30	-6	-6	0,8	TN..1604..
	3225P16-M	32	25	170	32,0	30	-6	-6	1,1	TN..1604..
	DTFNL 2020K16-M	20	20	125	25,0	29	-6	-6	0,4	TN..1604..
	2525M16-M	25	25	150	32,0	30	-6	-6	0,8	TN..1604..
	3225P16-M	32	25	170	32,0	30	-6	-6	1,1	TN..1604..
22	DTFNR 2525M22-M	25	25	150	32,0	30	-6	-6	0,8	TN..2204..
	3225P22-M	32	25	170	32,0	32	-6	-6	1,1	TN..2204..
	3232P22-M	32	32	170	40,0	32	-6	-6	1,4	TN..2204..
	DTFNL 2525M22-M	25	25	150	32,0	30	-6	-6	0,8	TN..2204..
	3225P22-M	32	25	170	32,0	32	-6	-6	1,1	TN..2204..
	3232P22-M	32	32	170	40,0	32	-6	-6	1,4	TN..2204..

Spare Parts, Parts included in delivery

Accessories*

For size	Clamp pin	Clamp screw	Floating wedge clamp	Insert shim	Shim/clamp key	Shim screw	Spring	Clamp kit
...16	FP1508	L84017-T09P	CD09-S	DTN160616	T09P-2	C03007-T09P	S5608	CD09-S09
...22	FP2012	L85021-T15P	CD12-S	DTN220616	T15P-7	C04008-T15P	S6912	CD12-S12

Please check availability in current price and stock-list

*To be ordered separately
Shim DTN220640 for insert TN..220432... to be ordered separately

Toolholders for inserts TNGA, TNMA, TNMG and TNMM



- For insert programme, see page(s) 385-389, 420
- γ_0° = Rake angle, λ_s° = Inclination angle
- For holder code key, see page(s) 14-15

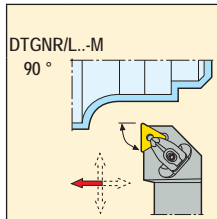
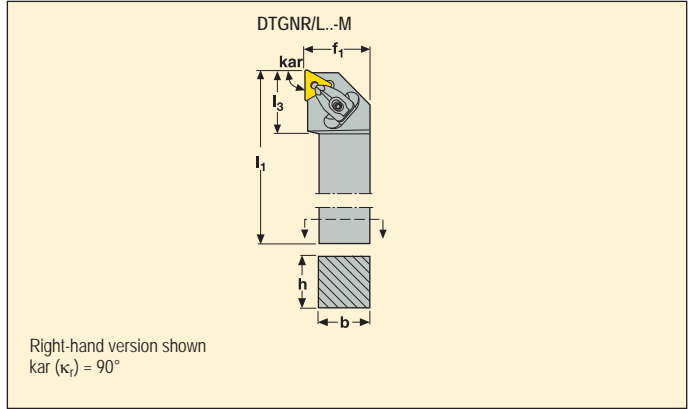

	Part No.	Dimensions in mm					γ_0°	λ_s°	KG	
		h	b	l ₁	f ₁	l ₃				
16	DTGNR 2020K16-M	20	20	125	25,0	29	-6	-6	0,5	TN..1604..
	2525M16-M	25	25	150	32,0	30	-6	-6	0,8	TN..1604..
	DTGNL 2020K16-M	20	20	125	25,0	29	-6	-6	0,5	TN..1604..
	2525M16-M	25	25	150	32,0	30	-6	-6	0,8	TN..1604..
22	DTGNR 2525M22-M	25	25	150	32,0	31	-6	-6	0,8	TN..2204..
	3225P22-M	32	25	170	32,0	32	-6	-6	1,1	TN..2204..
	3232P22-M	32	32	170	40,0	32	-6	-6	1,4	TN..2204..
	DTGNL 2525M22-M	25	25	150	32,0	31	-6	-6	0,8	TN..2204..
	3225P22-M	32	25	170	32,0	32	-6	-6	1,1	TN..2204..
3232P22-M	32	32	170	40,0	32	-6	-6	1,4	TN..2204..	

Spare Parts, Parts included in delivery

Accessories*

For size	Clamp pin	Clamp screw	Floating wedge clamp	Insert shim	Shim/clamp key	Shim screw	Spring	Clamp kit
...16	FP1508	L84017-T09P	CD09-S	DTN160616	T09P-2	C03007-T09P	S5608	CD09-S09
...22	FP2012	L85021-T15P	CD12-S	DTN220616	T15P-7	C04008-T15P	S6912	CD12-S12

Please check availability in current price and stock-list

*To be ordered separately
Shim DTN220640 for insert TN..220432.., to be ordered separately

Toolholders for inserts TNGA, TNMA, TNMG and TNMM



- For insert programme, see page(s) 385-389, 420
- γ_0° = Rake angle, λ_s° = Inclination angle
- For holder code key, see page(s) 14-15

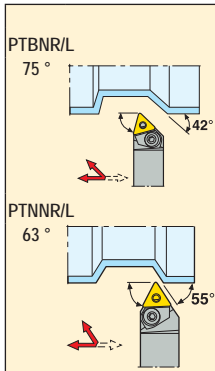
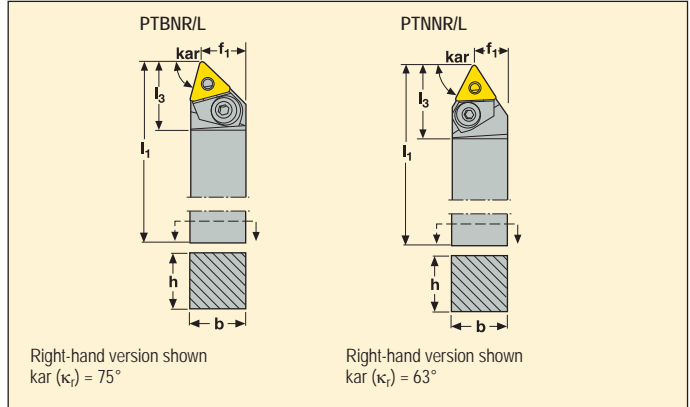

	Part No.	Dimensions in mm					γ_0°	λ_s°	KG	Key
		h	b	l_1	f_1	l_3				
16	PTBNR 2525M16	25	25	150	22,0	26	-5	-6	0,7	TN..1604..
	PTBNL 2525M16	25	25	150	22,0	26	-5	-6	0,7	TN..1604..
16	PTNNR 3225P16	32	25	170	13,0	28	-6	-5	1,0	TN..1604..
	PTNNL 3225P16	32	25	170	13,0	28	-6	-5	1,0	TN..1604..
22	PTNNR 3225P22	32	25	170	13,0	34	-6	-5	1,0	TN..2204..
	5032M22	50	32	150	16,5	34	-6	-5	1,7	TN..2204..
	PTNNL 3225P22	32	25	170	13,0	34	-6	-5	1,0	TN..2204..
	5032M22	50	32	150	16,5	34	-6	-5	1,7	TN..2204..

Spare Parts, Parts included in delivery

Accessories*

For size	Insert shim	Shim pin	Wedge clamp	Wedge key	Wedge screw	Shim key
R...M16	117.26-622	PP2009-T09P	110.26-641.1	3SMS795	117.26-655.1	T09P-2
L...M16	117.26-622	PP2009-T09P	110.26-640.1	3SMS795	117.26-655.1	T09P-2
R...P16	117.26-622	PP2009-T09P	110.26-640.1	3SMS795	117.26-655.1	T09P-2
L...P16	117.26-622	PP2009-T09P	110.26-641.1	3SMS795	117.26-655.1	T09P-2
R...P22	170.26-624	PP2015-1-T15P	110.26-643.1	4SMS795	170.26-655	T15P-2
R...M22	170.26-624	PP2015-1-T15P	110.26-642.1	4SMS795	170.26-655	T15P-2
L...P22	170.26-624	PP2015-1-T15P	110.26-642.1	4SMS795	170.26-655	T15P-2
L...M22	170.26-624	PP2015-1-T15P	110.26-642.1	4SMS795	170.26-655	T15P-2

Please check availability in current price and stock-list

*To be ordered separately

Toolholders for inserts TNGA, TNMA, TNMG and TNMM



- For insert programme, see page(s) 385-389, 420
- γ_0° = Rake angle, λ_s° = Inclination angle
- For holder code key, see page(s) 14-15

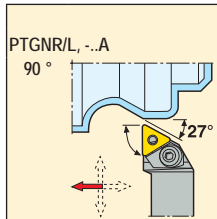
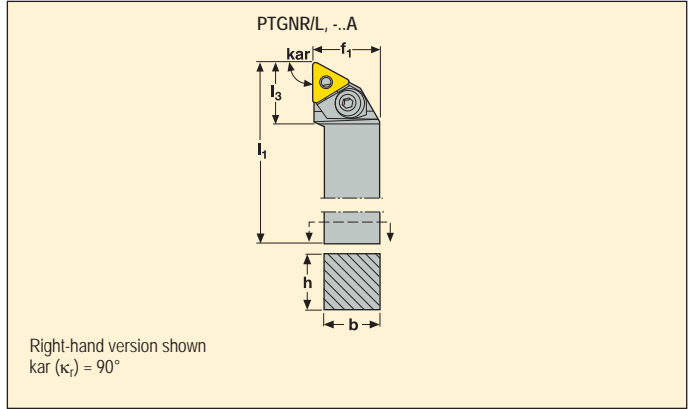

	Part No.	Dimensions in mm					γ_0°	λ_s°	KG	
		h	b	l ₁	f ₁	l ₃				
11	PTGNR 1616-11A	16	16	100	20,0	16	-5	-6	0,2	TN..1103..
	PTGNL 1616-11A	16	16	100	20,0	16	-5	-6	0,2	TN..1103..
16	PTGNR 2020K16	20	20	125	25,0	23	-5	-6	0,4	TN..1604..
	2525M16	25	25	150	32,0	23	-5	-6	0,7	TN..1604..
	3225P16	32	25	170	32,0	23	-5	-6	1,1	TN..1604..
	PTGNL 2020K16	20	20	125	25,0	23	-5	-6	0,4	TN..1604..
	2525M16	25	25	150	32,0	23	-5	-6	0,8	TN..1604..
	3225P16	32	25	170	32,0	23	-5	-6	1,1	TN..1604..
22	PTGNR 2525M22	25	25	150	32,0	29	-5	-6	0,8	TN..2204..
	3225P22	32	25	170	32,0	29	-5	-6	1,1	TN..2204..
	3232P22	32	32	170	40,0	29	-5	-6	1,3	TN..2204..
	PTGNL 2525M22	25	25	150	32,0	29	-5	-6	0,8	TN..2204..
	3225P22	32	25	170	32,0	29	-5	-6	1,1	TN..2204..
	3232P22	32	32	170	40,0	29	-5	-6	1,3	TN..2204..
27	PTGNR 4040T27	40	40	300	50,0	38	-5	-6	3,6	TN..2706..
	PTGNL 4040T27	40	40	300	50,0	38	-5	-6	3,6	TN..2706..

Spare Parts, Parts included in delivery

For size	Insert shim	Locking screw	Nut	Punch	Shim pin	Wedge clamp	Wedge key	Wedge screw	Shim key
R...11	117.26-620	136.26-654	-	117.26-686	117.26-654	110.26-639	2.5SMS795	117.26-657	2SMS795
L...11	117.26-620	136.26-654	-	117.26-686	117.26-654	110.26-638	2.5SMS795	117.26-657	2SMS795
R...16	117.26-622	-	-	-	PP2009-T09P	110.26-641.1	3SMS795	117.26-655.1	T09P-2
L...16	117.26-622	-	-	-	PP2009-T09P	110.26-640.1	3SMS795	117.26-655.1	T09P-2
R...22	170.26-624	-	-	-	PP2015-1-T15P	110.26-643.1	4SMS795	170.26-655	T15P-2
L...22	170.26-624	-	-	-	PP2015-1-T15P	110.26-642.1	4SMS795	170.26-655	T15P-2
R...27	117.26-628	-	170.26-651	117.26-687	126.26-650	110.26-645	5SMS795	110.26-655	4SMS795
L...27	117.26-628	-	170.26-651	117.26-687	126.26-650	110.26-644	5SMS795	110.26-655	4SMS795

Accessories*

Please check availability in current price and stock-list

*To be ordered separately

Toolholders for inserts TNGA, TNMA, TNMG, TNMM and TNMX



- For insert programme, see page(s) 385-390, 420
- γ_0° = Rake angle, λ_s° = Inclination angle
- For holder code key, see page(s) 14-15

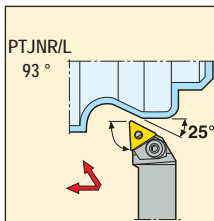
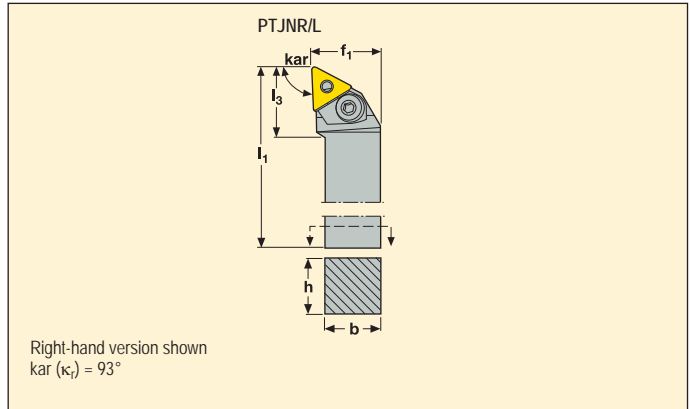

	Part No.	Dimensions in mm					γ_0°	λ_s°	KG	
		h	b	l_1	f_1	l_3				
16	PTJNR 2020K16	20	20	125	25,0	23	-5	-6	0,4	TN..1604..
	2525M16	25	25	150	32,0	23	-5	-6	0,7	TN..1604..
	3225P16	32	25	170	32,0	23	-5	-6	1,1	TN..1604..
	3232P16	32	32	170	40,0	23	-5	-6	1,3	TN..1604..
	PTJNL 2020K16	20	20	125	25,0	23	-5	-6	0,4	TN..1604..
	2525M16	25	25	150	32,0	23	-5	-6	0,7	TN..1604..
	3225P16	32	25	170	32,0	23	-5	-6	1,1	TN..1604..
	3232P16	32	32	170	40,0	23	-5	-6	1,3	TN..1604..
22	PTJNR 2525M22	25	25	150	32,0	29	-5	-6	0,8	TN..2204..
	3225P22	32	25	170	32,0	29	-5	-6	1,1	TN..2204..
	3232P22	32	32	170	40,0	29	-5	-6	1,3	TN..2204..
	4032R22	40	32	200	40,0	29	-5	-6	2,0	TN..2204..
	PTJNL 2525M22	25	25	150	32,0	29	-5	-6	0,8	TN..2204..
	3225P22	32	25	170	32,0	29	-5	-6	1,1	TN..2204..
	3232P22	32	32	170	40,0	29	-5	-6	1,3	TN..2204..
	4032R22	40	32	200	40,0	29	-5	-6	2,0	TN..2204..

Spare Parts, Parts included in delivery

For size	Insert shim	Shim pin	Wedge clamp	Wedge key	Wedge screw	Shim key
R...16	117.26-622	PP2009-T09P	110.26-641.1	3SMS795	117.26-655.1	T09P-2
L...16	117.26-622	PP2009-T09P	110.26-640.1	3SMS795	117.26-655.1	T09P-2
R...22	170.26-624	PP2015-1-T15P	110.26-643.1	4SMS795	170.26-655	T15P-2
L...22	170.26-624	PP2015-1-T15P	110.26-642.1	4SMS795	170.26-655	T15P-2

Accessories*

Please check availability in current price and stock-list

*To be ordered separately

Toolholders for inserts TNGA, TNMA, TNMG and TNMM



- For insert programme, see page(s) 385-389, 420
- γ_o° = Rake angle, λ_s° = Inclination angle
- For holder code key, see page(s) 14-15

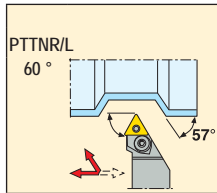
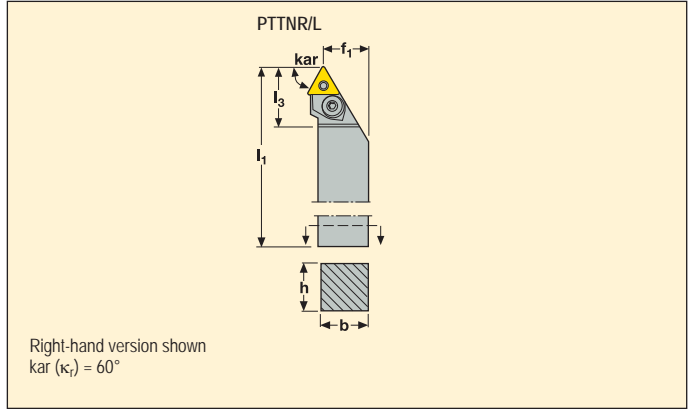

	Part No.	Dimensions in mm					γ_o°	λ_s°	KG	Key
		h	b	l_1	f_1	l_3				
16	PTTNR 2020K16	20	20	125	17,0	28	-6	-5	0,4	TN..1604..
	2525M16	25	25	150	22,0	28	-6	-5	0,8	TN..1604..
	PTTNL 2020K16	20	20	125	17,0	28	-6	-5	0,4	TN..1604..
	2525M16	25	25	150	22,0	28	-6	-5	0,8	TN..1604..

Spare Parts, Parts included in delivery

Accessories*

For size	Insert shim	Shim pin	Wedge clamp	Wedge key	Wedge screw	Shim key
R...16	117.26-622	PP2009-T09P	110.26-641.1	3SMS795	117.26-655.1	T09P-2
L...16	117.26-622	PP2009-T09P	110.26-640.1	3SMS795	117.26-655.1	T09P-2

Please check availability in current price and stock-list

*To be ordered separately

Toolholders for PCBN inserts TNGN and TNMN



- For insert programme, see page(s) 421-422, 424
- γ_0° = Rake angle, λ_s° = Inclination angle
- For holder code key, see page(s) 14-15

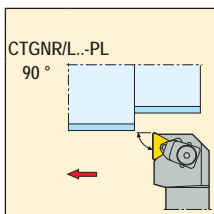
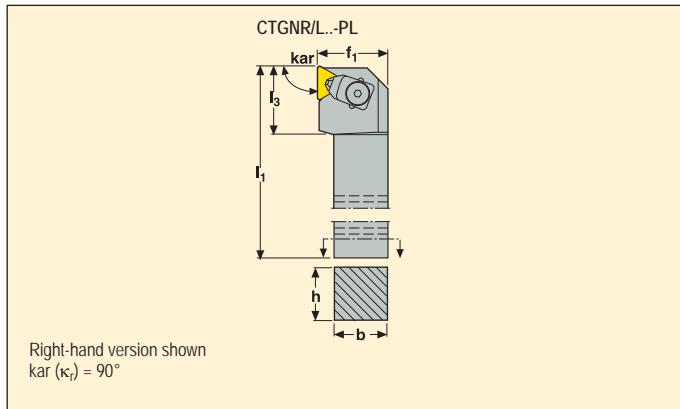

	Part No.	Dimensions in mm					γ_0°	λ_s°	KG	
		h	b	l_1	f_1	l_3				
11	CTGNR 3225P11-PL	32	25	170	32,2	31	-8	0	1,1	TN.N11..
	CTGNL 3225P11-PL	32	25	170	32,2	31	-8	0	1,1	TN.N11..
16	CTGNR 3225P16-PL	32	25	170	32,2	31	-8	0	1,2	TN.N1603..
	CTGNL 3225P16-PL	32	25	170	32,2	31	-8	0	1,2	TN.N1603..

Spare Parts, Parts included in delivery

Accessories*

For size	Cantilever clamp	Clamp key	Insert shim	Pressure plate	Setting screw	Shim screw	Shim key
...11							
...11	CC17P-06	4SMS795	CTN110308	P1311-06	179.17-686	CS2507-T07P	T07P-2
R...16	CC17P-09	4SMS795	175.10-621	P1311-09	179.17-686	F94009-T09P	T09P-2
L...16	CC17P-09	4SMS795	175.10-622	P1311-09	179.17-686	F94009-T09P	T09P-2

Please check availability in current price and stock-list

*To be ordered separately

Toolholders for PCBN inserts TNGN, TNGX, TNMN and TNMX

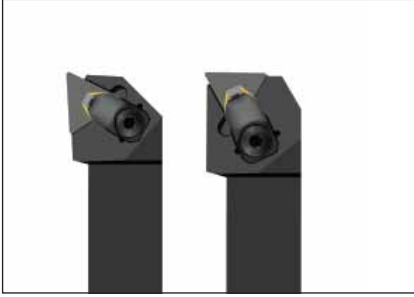

- For insert programme, see page(s) 421-425
- γ_0° = Rake angle, λ_s° = Inclination angle
- For holder code key, see page(s) 14-15

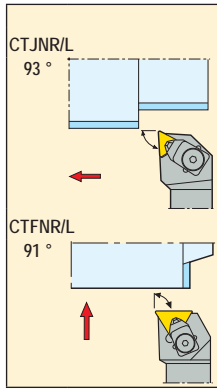
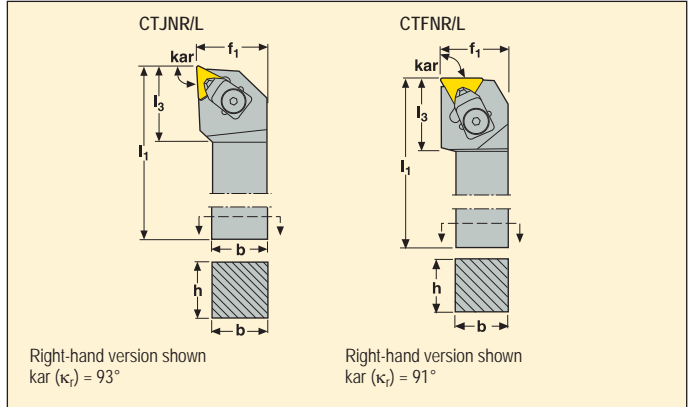

	Part No.	Dimensions in mm					γ_0°	λ_s°	KG	Warning
		h	b	l_1	f_1	l_3				
11	CTJNR 2525M11	25	25	150	32,2	23	-6	-6	0,8	TN.N/TN.X1103..
	CTJNL 2525M11	25	25	150	32,2	23	-6	-6	0,8	TN.N/TN.X1103..
16	CTJNR 2525M16	25	25	150	32,2	35	-6	-6	0,8	TN.N1604..
	CTJNL 2525M16	25	25	150	32,2	35	-6	-6	0,8	TN.N1604..
11	CTFNR 2525M11	25	25	150	32,2	29	-6	-6	0,8	TN.N/TN.X1103..
	CTFNL 2525M11	25	25	150	32,2	29	-6	-6	0,8	TN.N/TN.X1103..
16	CTFNR 2525M16	25	25	150	32,2	35	-6	-6	0,8	TN.N1604..

Spare Parts, Parts included in delivery

For size	Cantilever clamp	Clamp key	Insert shim	Pressure plate	Shim screw	Shim key
...11	CC17P-06	4SMS795	CTN110308	P1311-06	CS2507-T07P	T07P-2
...16	CC17P-09	4SMS795	175.10-621	P1311-09	F94009-T09P	T09P-2

Accessories*

Please check availability in current price and stock-list

*To be ordered separately
Shim CTN110312 for insert TN.N110312 and TNMX110308S-WZ, to be ordered separately
Shim 175.10-622 for insert TNGN1603., to be ordered separately

Toolholders for inserts VBGT, VBGW, VBMT, VBMT and VCGT



- For insert programme, see page(s) 391-392, 426, 435
- γ_0° = Rake angle, λ_s° = Inclination angle
- For holder code key, see page(s) 14-15

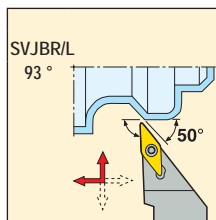
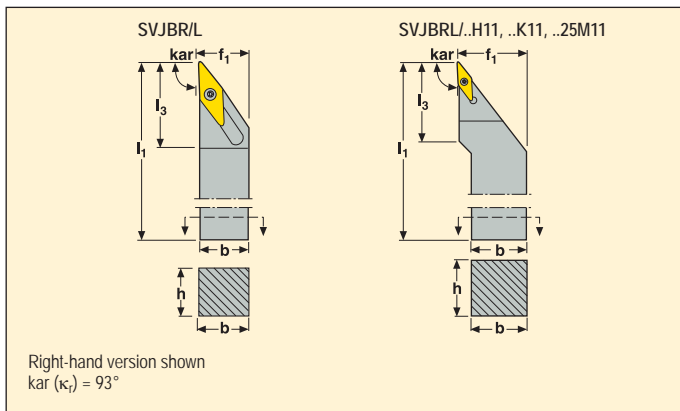

	Part No.	Dimensions in mm					γ_0°	λ_s°	KG	
		h	b	l_1	f_1	l_3				
11	SVJBR 1010M11	10	10	150	10,0	20	0	0	0,2	VB..1102..
	1212M11	12	12	150	12,0	20	0	0	0,2	VB..1102..
	1616H11	16	16	100	20,0	27	0	0	0,2	VB..1102..
	2020K11	20	20	125	25,0	27	0	0	0,4	VB..1102..
	2525M11	25	25	150	32,0	42	0	0	0,7	VB..1102..
	SVJBL 1010M11	10	10	150	10,0	20	0	0	0,2	VB..1102..
	1212M11	12	12	150	12,0	20	0	0	0,2	VB..1102..
	1616H11	16	16	100	20,0	27	0	0	0,2	VB..1102..
16	2020K11	20	20	125	25,0	27	0	0	0,4	VB..1102..
	2525M11	25	25	150	32,0	42	0	0	0,7	VB..1102..
	SVJBR 1212M16	12	12	150	12,5	30	0	0	0,2	VB..VC..1604..
	1616H16	16	16	100	16,5	30	0	0	0,2	VB..VC..1604..
	SVJBL 1212M16	12	12	150	12,0	30	0	0	0,2	VB..VC..1604..
	1616H16	16	16	100	16,0	30	0	0	0,2	VB..VC..1604..

Spare Parts, Parts included in delivery

For size	Insert key	Insert screw
...11	T07P-2	C02506-T07P
...16	T15P-2	C03512-T15P

Please check availability in current price and stock-list

Toolholders for inserts VBGT, VBGW, VBMT, VBMT and VCGT



- For insert programme, see page(s) 391-392, 426, 435
- γ_0° = Rake angle, λ_s° = Inclination angle
- For holder code key, see page(s) 14-15

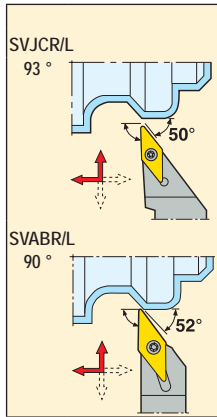
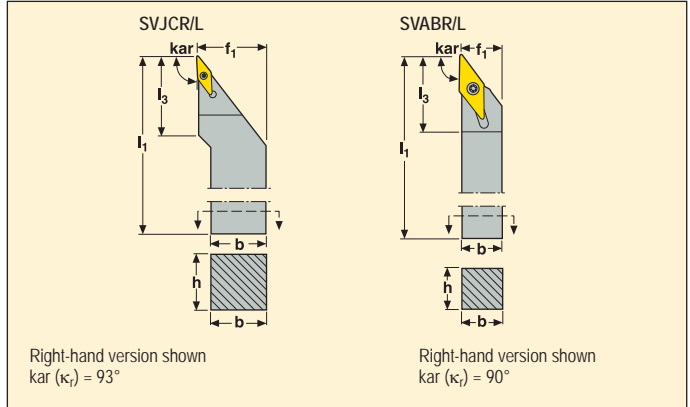

	Part No.	Dimensions in mm					γ_0°	λ_s°	KG	
		h	b	l_1	f_1	l_3				
11	SVJCR 2020K11	20	20	125	25,0	25	0	0	0,4	VC..1103..
	SVJCL 2020K11	20	20	125	25,0	25	0	0	0,4	VC..1103..
11	SVABR 1010M11	10	10	150	10,0	20	0	0	0,2	VB..1102..
	1212M11	12	12	150	12,0	20	0	0	0,2	VB..1102..
	SVABL 1010M11	10	10	150	10,0	20	0	0	0,2	VB..1102..
	1212M11	12	12	150	12,0	20	0	0	0,2	VB..1102..
16	SVABR 1212M16	12	12	150	12,0	30	0	0	0,2	VB../VC..1604..
	1616H16	16	16	100	16,0	30	0	0	0,2	VB../VC..1604..
	SVABL 1212M16	12	12	150	12,0	30	0	0	0,2	VB../VC..1604..
	1616H16	16	16	100	16,0	30	0	0	0,2	VB../VC..1604..

Spare Parts, Parts included in delivery

For size	Insert key	Insert screw
...11	T07P-2	C02506-T07P
...16	T15P-2	C03510-T15P

Please check availability in current price and stock-list

Toolholders for inserts VBG, VBGW, VBMT, VBMT and VCGT



- For insert programme, see page(s) 391-392, 426, 435
- γ_0° = Rake angle, λ_s° = Inclination angle
- For holder code key, see page(s) 14-15

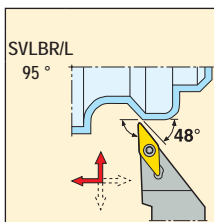
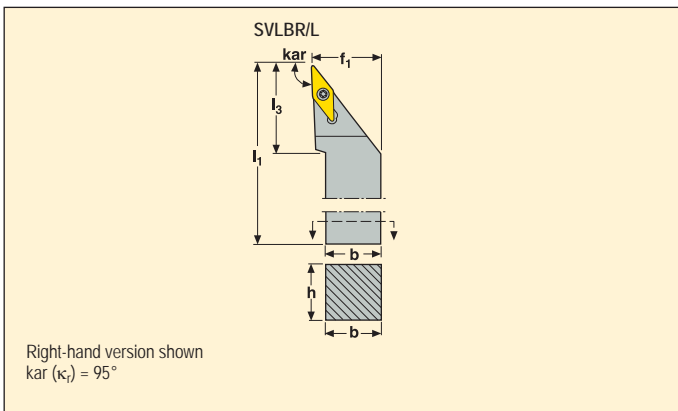

Part No.	Dimensions in mm					γ_0°	λ_s°	KG	Key	
	h	b	l ₁	f ₁	l ₃					
16	SVLBR 2020K16	20	20	125	25,0	40	0	0	0,4	VB/VC..1604..
	2525M16	25	25	150	32,0	40	0	0	0,7	VB/VC..1604..
	3225P16	32	25	170	32,0	40	0	0	1,0	VB/VC..1604..
	SVLBL 2020K16	20	20	125	25,0	40	0	0	0,4	VB/VC..1604..
	2525M16	25	25	150	32,0	40	0	0	0,7	VB/VC..1604..
	3225P16	32	25	170	32,0	40	0	0	1,0	VB/VC..1604..

Spare Parts, Parts included in delivery

Accessories, to be ordered separately

For size	Insert key	Insert screw	Insert shim	Shim screw	Shim key
...16	T15P-2	C03512-T15P	171.19-620	CA3510	9/64SMS875

Please check availability in current price and stock-list

Toolholders for inserts VBGT, VBGW, VBMT, VBMT and VCGT



- For insert programme, see page(s) 391-392, 426, 435
- γ_0° = Rake angle, λ_s° = Inclination angle
- For holder code key, see page(s) 14-15

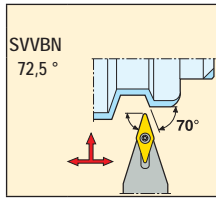
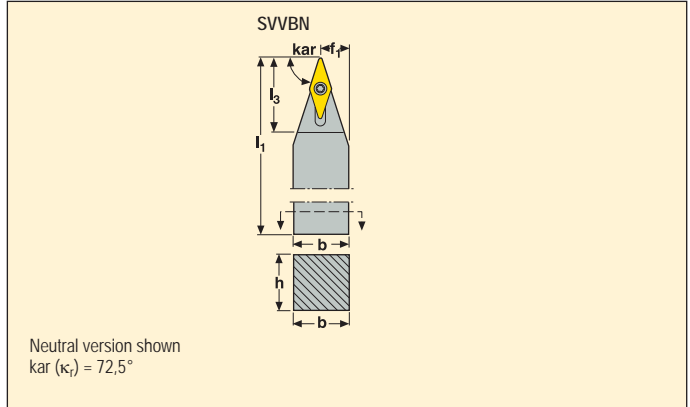

Part No.	Dimensions in mm					γ_0°	λ_s°	KG	Key	
	h	b	l_1	f_1	l_3					
11	SVVBN 1010M11	10	10	150	5,3	25	0	0	0,2	VB..1102..
	1212M11	12	12	150	6,3	25	0	0	0,2	VB..1102..
	1616H11	16	16	100	8,3	26	0	0	0,2	VB..1102..
	2020K11	20	20	125	10,3	26	0	0	0,4	VB..1102..
	2525M11	25	25	150	12,8	26	0	0	0,7	VB..1102..
16	SVVBN 1212M16	12	12	150	6,3	30	0	0	0,2	VB../VC..1604..
	1616H16	16	16	100	8,3	30	0	0	0,2	VB../VC..1604..
	2020K16	20	20	125	10,6	35	0	0	0,4	VB../VC..1604..
	2525M16	25	25	150	13,1	35	0	0	0,7	VB../VC..1604..
	3225P16	32	25	170	13,1	35	0	0	1,0	VB../VC..1604..

Spare Parts, Parts included in delivery

Accessories, to be ordered separately

For size	Insert key	Insert screw	Insert shim	Shim screw	Shim key
...11	T07P-2	C02506-T07P	-	-	-
...1212M16/1616H16	T15P-2	C03510-T15P	-	-	-
...16	T15P-2	C03512-T15P	171.19-620	CA3510	9/64SMS875

Please check availability in current price and stock-list

Toolholders for PCBN inserts VNGA and VNMA



- For insert programme, see page(s) 427-428
- γ_0° = Rake angle, λ_s° = Inclination angle
- For holder code key, see page(s) 14-15

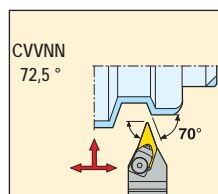
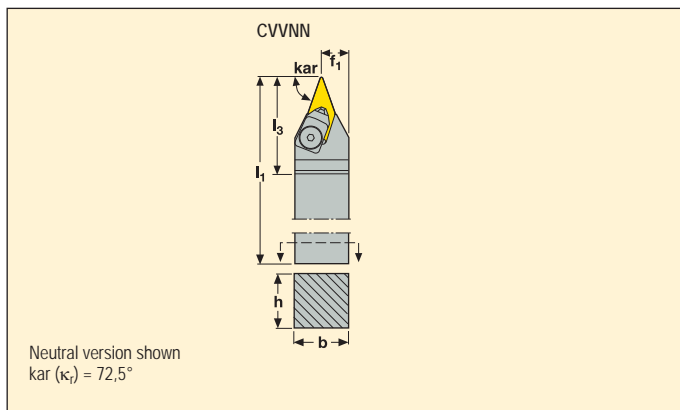

Part No.	Dimensions in mm					γ_0°	λ_s°	KG	Key
	h	b	l_1	f_1	l_3				
16 CVVNN 3225P16	32	25	170	13,1	42	-15	-5	1,0	VN.A1604..

Spare Parts, Parts included in delivery

Accessories*

For size	Cantilever clamp	Clamp key	Insert shim	Pressure plate	Shim pin	Shim key
...16	CC20P	4SMS795	VSN160316	P1311-09	MN0909L-T09P	T09P-2

Please check availability in current price and stock-list

*To be ordered separately

Toolholders for inserts VNGA, VNGG, VNGM, VNMA, VNMG and VNMU

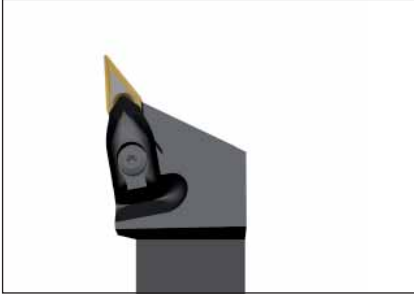

- For insert programme, see page(s) 393-394, 427-428
- γ_0° = Rake angle, λ_s° = Inclination angle
- For holder code key, see page(s) 14-15

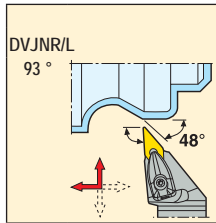
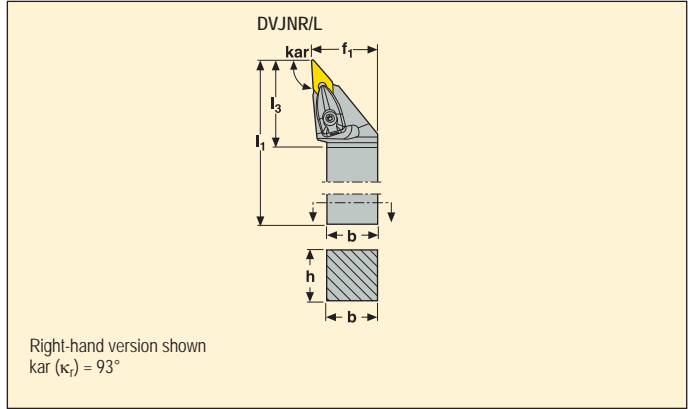

	Part No.	Dimensions in mm					γ_0°	λ_s°	KG	
		h	b	l_1	f_1	l_3				
13	DVJNR 1616H13	16	16	100	20,0	42	-4,5	-13,5	0,2	VN..1304..
	2020K13	20	20	125	25,0	42	-4,5	-13,5	0,4	VN..1304..
	2525M13	25	25	150	32,0	42	-4,5	-13,5	0,7	VN..1304..
	DVJNL 1616H13	16	16	100	20,2	42	-4,5	-13,5	0,2	VN..1304..
	2020K13	20	20	125	25,0	42	-4,5	-13,5	0,4	VN..1304..
	2525M13	25	25	150	32,0	42	-4,5	-13,5	0,7	VN..1304..
16	DVJNR 2020K16	20	20	125	25,0	41	-4,5	-13,5	0,4	VN..1604..
	2525M16	25	25	150	32,0	41	-4,5	-13,5	0,7	VN..1604..
	3225P16	32	25	170	32,0	41	-4,5	-13,5	1,0	VN..1604..
	DVJNL 2020K16	20	20	125	25,0	41	-4,5	-13,5	0,4	VN..1604..
	2525M16	25	25	150	32,0	41	-4,5	-13,5	0,7	VN..1604..
	3225P16	32	25	170	32,0	41	-4,5	-13,5	1,0	VN..1604..

Spare Parts, Parts included in delivery

Accessories*

For size	Clamp pin	Clamp screw	Floating wedge clamp	Insert shim	Shim/clamp key	Shim screw	Spring	Clamp kit
...13	FP1508	L84017-T09P	CD08-S	PVN130308	T09P-2	CS5008-T09P	S5608	CD08-V13
...16	FP2012	L85021-T15P	CD19-S-V16	DVN160310	T15P-7	C03508-T15P	S6912	CD19-V16

Please check availability in current price and stock-list

*To be ordered separately

Toolholders for inserts VNGA, VNGG, VNGM, VNMA and VNMG



- For insert programme, see page(s) 393-394, 427-428
- γ_0° = Rake angle, λ_s° = Inclination angle
- For holder code key, see page(s) 14-15

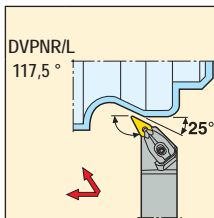
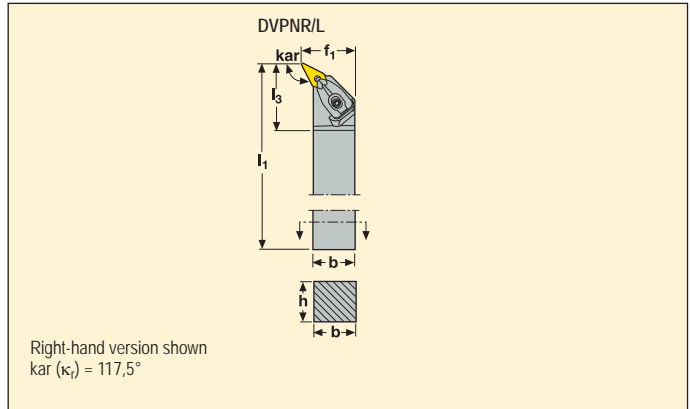

	Part No.	Dimensions in mm					γ_0°	λ_s°	KG	
		h	b	l_1	f_1	l_3				
16	DVPNR 2020K16	20	20	125	25,0	42	-4,5	-13,5	0,5	VN..1604..
	2525M16	25	25	150	32,0	41	-4,5	-13,5	0,8	VN..1604..
	3232P16	32	32	170	40,0	41	-4,5	-13,5	1,4	VN..1604..
	DVPL 2020K16	20	20	125	25,0	42	-4,5	-13,5	0,5	VN..1604..
	2525M16	25	25	150	32,0	41	-4,5	-13,5	0,8	VN..1604..
	3232P16	32	32	170	40,0	41	-4,5	-13,5	1,4	VN..1604..

Spare Parts, Parts included in delivery

Accessories*

For size	Clamp pin	Clamp screw	Floating wedge clamp	Insert shim	Shim/clamp key	Shim screw	Spring	Clamp kit
...16	FP2012	L85021-T15P	CD19-S-V16	DVN160310	T15P-7	C03508-T15P	S6912	CD19-V16

Please check availability in current price and stock-list

*To be ordered separately

Toolholders for PCBN inserts VNMA



- For insert programme, see page(s) 427-428
- γ_0° = Rake angle, λ_s° = Inclination angle
- For holder code key, see page(s) 14-15

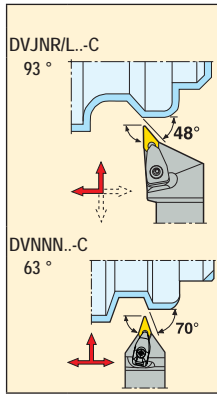
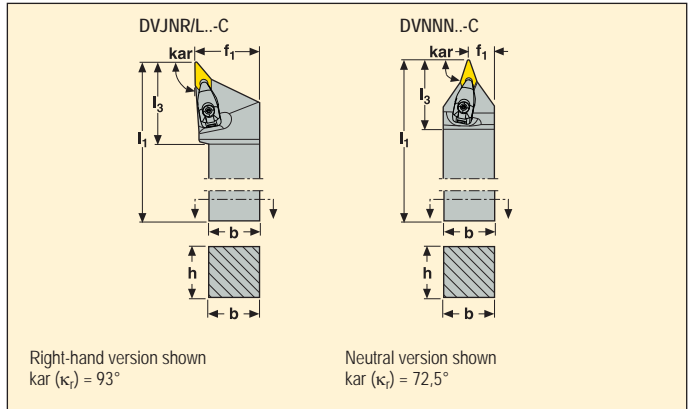

	Part No.	Dimensions in mm					γ_0°	λ_s°	KG	
		h	b	l_1	f_1	l_3				
13	DVJNR 3225P13-C	32	25	170	32,0	36	-4,5	-13,5	1,1	VNMA1304..
	DVJNL 3225P13-C	32	25	170	32,0	36	-4,5	-13,5	1,1	VNMA1304..
13	DVNNN 3225P13-C	32	25	170	13,0	37	-5,0	-15,0	1,0	VNMA1304..

Spare Parts, Parts included in delivery

Accessories*

For size	Clamp pin	Clamp screw	Floating wedge clamp	Insert shim	Shim/clamp key	Shim screw	Spring	Clamp kit
...13	FP1508	L84017-T09P	CC08P-SET	PVN130308	T09P-2	CS5008-T09P	S5608	CC08P-V13

Please check availability in current price and stock-list

*To be ordered separately

Toolholders for inserts WCMT



- For insert programme, see page(s) 395
- γ_0° = Rake angle, λ_s° = Inclination angle
- For holder code key, see page(s) 14-15

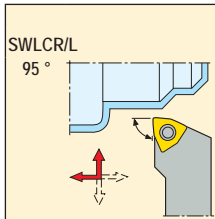
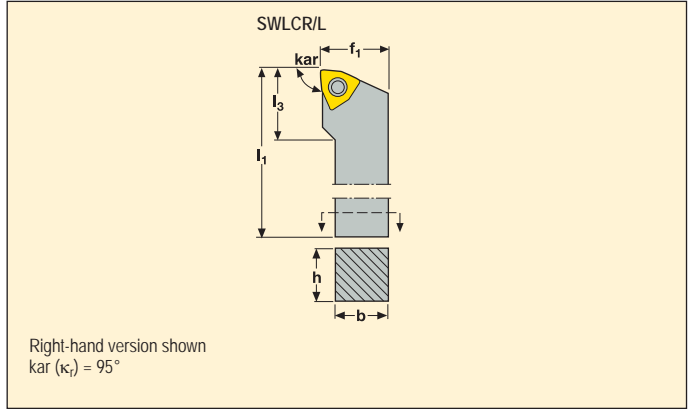

Part No.	Dimensions in mm					γ_0°	λ_s°	KG	Icon	
	h	b	l ₁	f ₁	l ₃					
06	SWLCR 1616H06	16	16	100	20,0	20	0	0	0,2	WCMT06T3..
	2020K06	20	20	125	25,0	21	0	0	0,4	WCMT06T3..
	SWLCL 1616H06	16	16	100	20,0	20	0	0	0,2	WCMT06T3..
	2020K06	20	20	125	25,0	21	0	0	0,4	WCMT06T3..

Spare Parts, Parts included in delivery

For size	Insert key	Insert screw
...06	T15P-2	C03510-T15P

Please check availability in current price and stock-list

Toolholders for inserts WNGA, WNGG, WNMA, WNMG and WNMM



- For insert programme, see page(s) 395-399, 429
- γ_0° = Rake angle, λ_s° = Inclination angle
- For holder code key, see page(s) 14-15

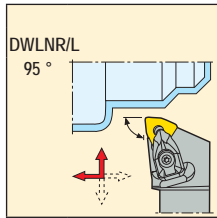
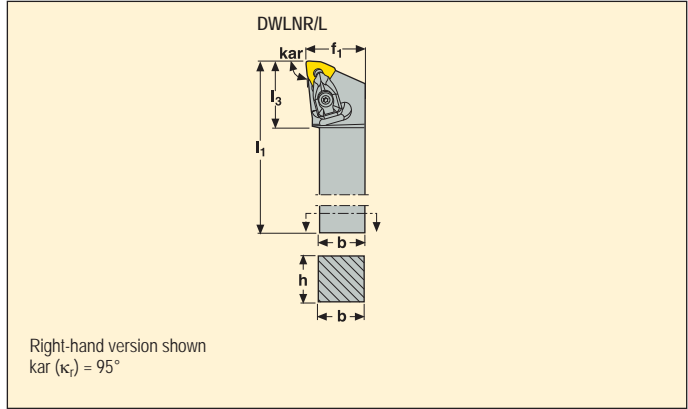

	Part No.	Dimensions in mm					γ_0°	λ_s°	KG	
		h	b	l ₁	f ₁	l ₃				
06	DWLNR 1616H06	16	16	100	20,0	31	-6	-6	0,3	WN..0604..
	2020K06	20	20	125	25,0	31	-6	-6	0,4	WN..0604..
	2525M06	25	25	150	32,0	30	-6	-6	0,8	WN..0604..
	3225P06	32	25	170	32,0	32	-6	-6	1,1	WN..0604..
	3232P06	32	32	170	40,0	32	-6	-6	1,4	WN..0604..
	DWLNL 1616H06	16	16	100	20,0	31	-6	-6	0,3	WN..0604..
	2020K06	20	20	125	25,0	31	-6	-6	0,4	WN..0604..
	2525M06	25	25	150	32,0	30	-6	-6	0,8	WN..0604..
08	3225P06	32	25	170	32,0	32	-6	-6	1,1	WN..0604..
	3232P06	32	32	170	40,0	32	-6	-6	1,4	WN..0604..
	DWLNR 2020K08	20	20	125	25,0	31	-6	-6	0,4	WN..0804..
	2525M08	25	25	150	32,0	35	-6	-6	0,8	WN..0804..
	3225P08	32	25	170	32,0	35	-6	-6	1,1	WN..0804..
	3232P08	32	32	170	40,0	35	-6	-6	1,4	WN..0804..
	DWLNL 2020K08	20	20	125	25,0	31	-6	-6	0,4	WN..0804..
	2525M08	25	25	150	32,0	35	-6	-6	0,8	WN..0804..
3225P08	32	25	170	32,0	35	-6	-6	1,1	WN..0804..	
3232P08	32	32	170	40,0	35	-6	-6	1,4	WN..0804..	

Spare Parts, Parts included in delivery

Accessories*

For size	Clamp pin	Clamp screw	Floating wedge clamp	Insert shim	Shim/clamp key	Shim screw	Spring	Clamp kit
...06	FP1508	L84017-T09P	CD09-S	DWN060310	T09P-2	C03007-T09P	S5608	CD09-S09
...08	FP2012	L85021-T15P	CD12-S	DWN080416	T15P-7	C04008-T15P	S6912	CD12-S12

Please check availability in current price and stock-list

*To be ordered separately
Shim DWN080316 for insert WN..0806.., to be ordered separately

Toolholders for inserts WNGA, WNGG, WNMA, WNMG and WNMM



- For insert programme, see page(s) 395-399, 429
- γ_0° = Rake angle, λ_s° = Inclination angle
- For holder code key, see page(s) 14-15

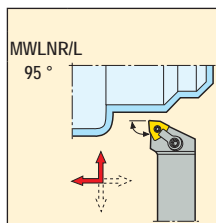
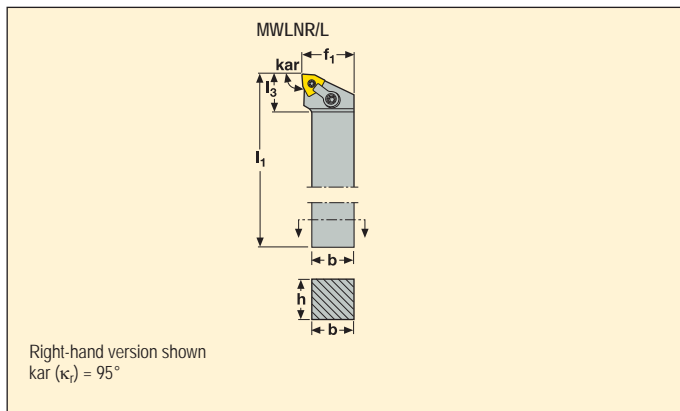

	Part No.	Dimensions in mm					γ_0°	λ_s°	KG	
		h	b	l_1	f_1	l_3				
08	MWLNR 2020K08	20	20	125	25,0	31	-6	-6	0,5	WN..0804..
	2525M08	25	25	150	32,0	31	-6	-6	0,8	WN..0804..
	3225P08	32	25	170	32,0	31	-6	-6	1,1	WN..0804..
	3232P08	32	32	170	40,0	31	-6	-6	1,4	WN..0804..
	MWLNL 2020K08	20	20	125	25,0	31	-6	-6	0,5	WN..0804..
	2525M08	25	25	150	32,0	31	-6	-6	0,8	WN..0804..
	3225P08	32	25	170	32,0	31	-6	-6	1,1	WN..0804..
	3232P08	32	32	170	40,0	31	-6	-6	1,4	WN..0804..

Spare Parts, Parts included in delivery

Accessories*

For size	Cantilever clamp	Clamp screw	Insert shim	Shim/clamp key	Shim pin	Plug
...08	MC21	LD6025-T15P	MWN080412	T15P-2	MN1215T-T15P	P3

Please check availability in current price and stock-list

*To be ordered separately
Shim MWN080312 for insert WN..0806.., to be ordered separately

Toolholders for inserts WNGA, WNGG, WNMA, WNMG and WNMM



- For insert programme, see page(s) 395-399, 429
- γ_0° = Rake angle, λ_s° = Inclination angle
- For holder code key, see page(s) 14-15

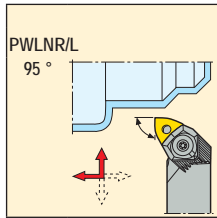
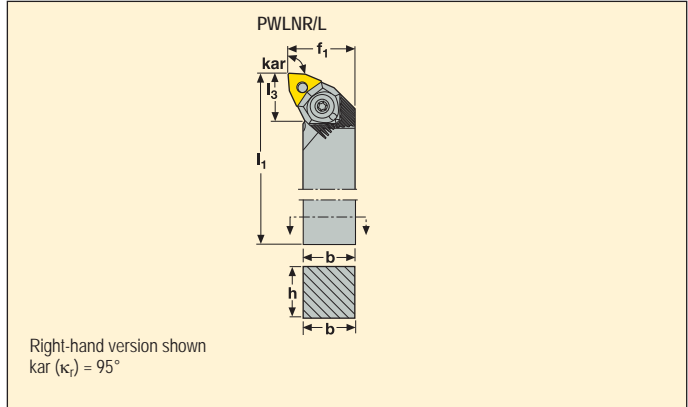

	Part No.	Dimensions in mm					γ_0°	λ_s°	KG	
		h	b	l_1	f_1	l_3				
06	PWLNR 1616H06	16	16	100	20,0	21	-6	-6	0,2	WN..0604..
	2020K06	20	20	125	25,0	21	-6	-6	0,4	WN..0604..
	2525M06	25	25	150	32,0	21	-6	-6	0,7	WN..0604..
	3225P06	32	25	170	32,0	21	-6	-6	1,1	WN..0604..
	3232P06	32	32	170	40,0	21	-6	-6	1,4	WN..0604..
	PWLN L 1616H06	16	16	100	20,0	21	-6	-6	0,2	WN..0604..
	2020K06	20	20	125	25,0	21	-6	-6	0,4	WN..0604..
	2525M06	25	25	150	32,0	21	-6	-6	0,7	WN..0604..
08	3225P06	32	25	170	32,0	21	-6	-6	1,1	WN..0604..
	3232P06	32	32	170	40,0	21	-6	-6	1,4	WN..0604..
	PWLNR 2020K08	20	20	125	25,0	27	-6	-6	0,4	WN..0804..
	2525M08	25	25	150	32,0	27	-6	-6	0,8	WN..0804..
	3225P08	32	25	170	32,0	27	-6	-6	1,1	WN..0804..
	3232P08	32	32	170	40,0	27	-6	-6	1,3	WN..0804..
	PWLN L 2020K08	20	20	125	25,0	27	-6	-6	0,4	WN..0804..
	2525M08	25	25	150	32,0	27	-6	-6	0,8	WN..0804..
3225P08	32	25	170	32,0	27	-6	-6	1,1	WN..0804..	
3232P08	32	32	170	40,0	27	-6	-6	1,3	WN..0804..	

Spare Parts, Parts included in delivery

For size	Insert shim	Setting screw	Shim pin	Wedge clamp	Wedge key	Wedge screw	Shim key
...H06	WAE060312	L82511-T07P	PP1409-T09P	WNW06HD	T20P-7	WS1920-T20P	T09P-2
...06	WAE060312	L82511-T07P	PP2109-T09P	WNW06HD	T20P-7	WS1920-T20P	T09P-2
...08	WAE080412	L82511-T07P	PP2015-1-T15P	WNW08HD	T25P-7	WS2325-T25P	T15P-2

Accessories*

Please check availability in current price and stock-list

*To be ordered separately
 Shim WAE080312 for insert WNM.0806.., to be ordered separately
 Wedge WNW08 for intert WNMM08.., to be ordered separately

Toolholders for PCBN inserts WNGA and WNMA



- For insert programme, see page(s) 429-430
- γ_0° = Rake angle, λ_s° = Inclination angle
- For holder code key, see page(s) 14-15

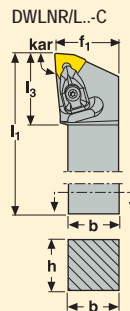

Right-hand version shown
 $\text{kar } (\kappa_r) = 95^\circ$

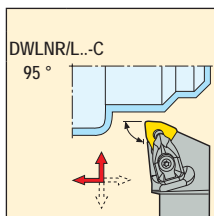

Symbol	Part No.	Dimensions in mm					γ_0°	λ_s°	KG	Symbol
		h	b	I ₁	f ₁	I ₃				
06	DWLNR 3225P06-C	32	25	170	32,0	32	-6	-6	1,1	WN.A0604..
	DWLNL 3225P06-C	32	25	170	32,0	32	-6	-6	1,1	WN.A0604..
08	DWLNR 3225P08-C	32	25	170	32,0	35	-6	-6	1,1	WN.A0804..
	DWLNL 3225P08-C	32	25	170	32,0	35	-6	-6	1,1	WN.A0804..

Spare Parts, Parts included in delivery

Accessories*

For size	Clamp pin	Clamp screw	Floating wedge clamp	Insert shim	Shim/clamp key	Shim screw	Spring	Clamp kit
...06	FP1508	L84017-T09P	CC09P-SET	DWN060310	T09P-2	C03007-T09P	S5608	CC09P-D11
...08	FP2012	L85021-T15P	CC12P-SET	DWN080416	T15P-2	C04008-T15P	S6912	CC12P-S12

Please check availability in current price and stock-list

*To be ordered separately

Toolholders for inserts LNMX



- For insert programme, see page(s) 367
- γ_0° = Rake angle, λ_s° = Inclination angle
- For holder code key, see page(s) 14-15

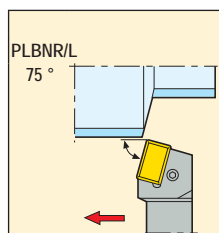
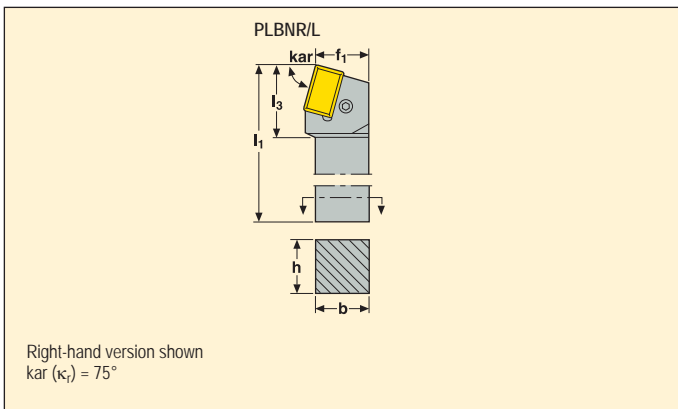

	Part No.	Dimensions in mm					γ_0°	λ_s°	KG	
		h	b	l ₁	f ₁	l ₃				
40	PLBNR 6060V40-A	60	60	400	61,4	62	-6	-6	11,3	LNMX401432
	PLBNL 6060V40-A	60	60	400	61,4	62	-6	-6	11,3	LNMX401432
50	PLBNR 6060V50	60	60	400	60,0	68	-6	-6	11,5	LNMX501432
	PLBNL 6060V50	60	60	400	60,0	68	-6	-6	11,5	LNMX501432

Spare Parts, Parts included in delivery

For size	Insert lever	Insert shim	Lever key	Punch	Screw	Shim pin
...40	PP1325	PLN400632	5SMS795	MP25	LS1240	RP1312
...50	PP1325	PLN500632	5SMS795	MP25	LS1240	RP1312

Please check availability in current price and stock-list

Toolholders for inserts CCGT, CCGW, CCGX, CCMT and CCMW



- For insert programme, see page(s) 343-347, 400-401, 431-432
- γ_0° = Rake angle, λ_s° = Inclination angle
- For holder code key, see page(s) 12-13

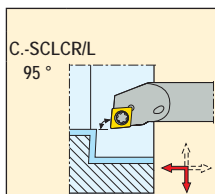
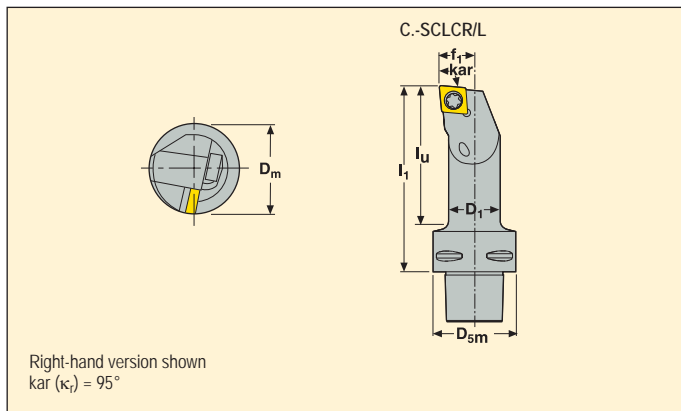

Capto size	Part No.	Dimensions in mm							γ_0°	λ_s°	KG	Key
		D_1	D_{5m}	f_1	l_1	l_3	D_m min	l_U				
C3	09	C3-SCLCR -11065-09	16	32	11,0	65	48	20	0	-12	0,2	CC..09T3..
		-13075-09	20	32	13,0	75	59	25	0	-8	0,3	CC..09T3..
		C3-SCLCL -11065-09	16	32	11,0	65	48	20	0	-12	0,2	CC..09T3..
		-13075-09	20	32	13,0	75	59	25	0	-8	0,3	CC..09T3..

Spare Parts, Parts included in delivery

For size	Insert key	Insert screw
11065-09	T15P-2	C03508-T15P
13075-09	T15P-2	C03508-T15P

Please check availability in current price and stock-list

Toolholders for inserts CCGT, CCGW, CCGX, CCMT and CCMW



- For insert programme, see page(s) 343-347, 400-401, 431-432
- γ_0 = Rake angle, λ_s = Inclination angle
- For holder code key, see page(s) 12-13

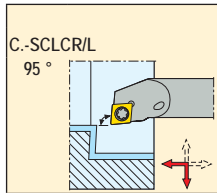
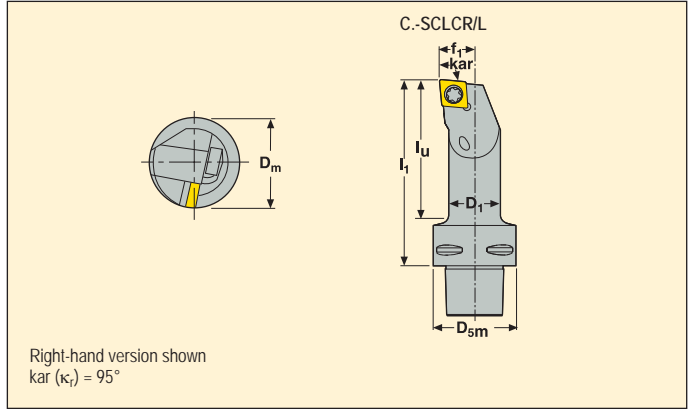

Capto size	Part No.	Dimensions in mm							γ_0	λ_s	KG	Key
		D ₁	D _{5m}	f ₁	l ₁	l ₃	D _m min					
C4	09	C4-SCLCR -11070-09	16	40	11,0	70	47	20	0	-12	0,4	CC..09T3..
		-13080-09	20	40	13,0	80	57	25	0	-8	0,4	CC..09T3..
		-17090-09	25	40	17,0	90	68	32	0	-6	0,5	CC..09T3..
	C4-SCLCL	-27080-09	40	40	27,0	80	60	50	0	-6	0,5	CC..09T3..
		-11070-09	16	40	11,0	70	47	20	0	-12	0,4	CC..09T3..
		-13080-09	20	40	13,0	80	57	25	0	-8	0,4	CC..09T3..
		-17090-09	25	40	17,0	90	68	32	0	-6	0,5	CC..09T3..
-27080-09	40	40	27,0	80	60	50	0	-6	0,7	CC..09T3..		
12	C4-SCLCR	-17090-12	25	40	17,0	90	68	32	0	-6	0,5	CC..1204..
		-22110-12	32	40	22,0	110	89	40	0	-10	0,8	CC..1204..
		-27080-12	40	40	27,0	80	60	50	0	-8	0,7	CC..1204..
	C4-SCLCL	-17090-12	25	40	17,0	90	68	32	0	-6	0,5	CC..1204..
		-22110-12	32	40	22,0	110	89	40	0	-10	0,8	CC..1204..
-27080-12	40	40	27,0	80	60	50	0	-8	0,7	CC..1204..		

Spare Parts, Parts included in delivery

For size	Insert key	Insert screw	Insert shim	Shim screw	Shim key
11070-09	T15P-2	C03508-T15P	-	-	-
13080-09	T15P-2	C03508-T15P	-	-	-
17090-09	T15P-2	C03510-T15P	-	-	-
27080-09	T15P-2	C03512-T15P	SCN090308	CA3507	9/64SMS875
17090-12	T15P-2	C04010-T15P	-	-	-
22110-12	T15P-2	C04014-T15P	SCN12T308	CA4010	4SMS795
27080-12	T15P-2	C04014-T15P	SCN12T308	CA4010	4SMS795

Accessories, to be ordered separately

Please check availability in current price and stock-list

Toolholders for inserts CCGT, CCGW, CCGX, CCMT and CCMW



- For insert programme, see page(s) 343-347, 400-401, 431-432
- γ_0° = Rake angle, λ_s° = Inclination angle
- For holder code key, see page(s) 12-13

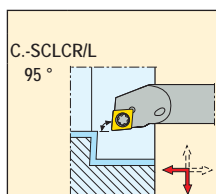
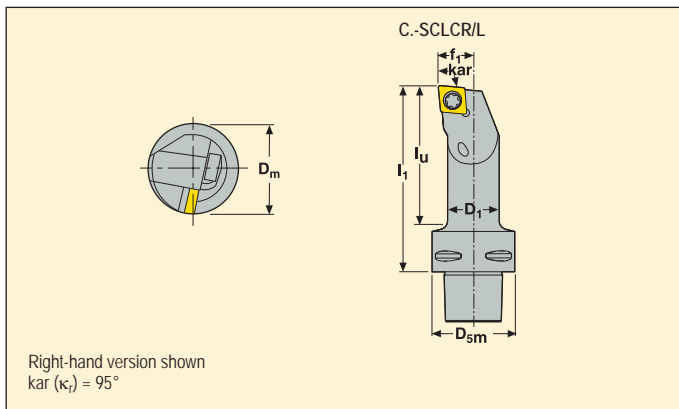

Capto size	Part No.	Dimensions in mm							γ_0°	λ_s°	KG	Key
		D ₁	D _{5m}	f ₁	l ₁	l ₃	D _m min					
C5	09	C5-SCLCR -11070-09	16	50	11,0	70	46	20	0	-12	0,5	CC..09T3..
		-13080-09	20	50	13,0	80	56	25	0	-8	0,6	CC..09T3..
		-17090-09	25	50	17,0	90	67	32	0	-6	0,7	CC..09T3..
		-35100-09	50	50	35,0	100	80	50	0	-4	1,4	CC..09T3..
	C5-SCLCL	-11070-09	16	50	11,0	70	46	20	0	-12	0,5	CC..09T3..
		-13080-09	20	50	13,0	80	56	25	0	-8	0,6	CC..09T3..
		-17090-09	25	50	17,0	90	67	32	0	-6	0,7	CC..09T3..
		-35100-09	50	50	35,0	100	80	50	0	-4	1,4	CC..09T3..
12	C5-SCLCR	-17090-12	25	50	17,0	90	67	32	0	-6	0,7	CC..1204..
		-22110-12	32	50	22,0	110	88	40	0	-10	0,9	CC..1204..
		-27140-12	40	50	27,0	140	119	50	0	-8	1,5	CC..1204..
		-35100-12	50	50	35,0	100	80	50	0	-6	1,4	CC..1204..
	C5-SCLCL	-17090-12	25	50	17,0	90	67	32	0	-6	0,7	CC..1204..
		-22110-12	32	50	22,0	110	88	40	0	-10	0,9	CC..1204..
		-27140-12	40	50	27,0	140	119	50	0	-8	1,5	CC..1204..

Spare Parts, Parts included in delivery

For size	Insert key	Insert screw	Insert shim	Shim screw	Shim key
11070-09	T15P-2	C03508-T15P	-	-	-
13080-09	T15P-2	C03508-T15P	-	-	-
17090-09	T15P-2	C03510-T15P	-	-	-
35100-09	T15P-2	C03512-T15P	SCN090308	CA3507	9/64SMS875
17090-12	T15P-2	C04014-T15P	SCN12T308	CA4010	4SMS795
22110-12	T15P-2	C04014-T15P	SCN12T308	CA4010	4SMS795
27140-12	T15P-2	C04014-T15P	SCN12T308	CA4010	4SMS795
35100-12	T15P-2	C04014-T15P	SCN12T308	CA4010	4SMS795

Accessories, to be ordered separately

Please check availability in current price and stock-list

Toolholders for inserts CNGG, CNMA, CNMG and CNMM



- For insert programme, see page(s) 348-355, 402, 431
- γ_0° = Rake angle, λ_s° = Inclination angle
- For holder code key, see page(s) 12-13

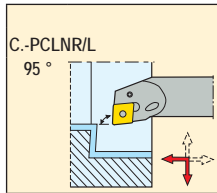
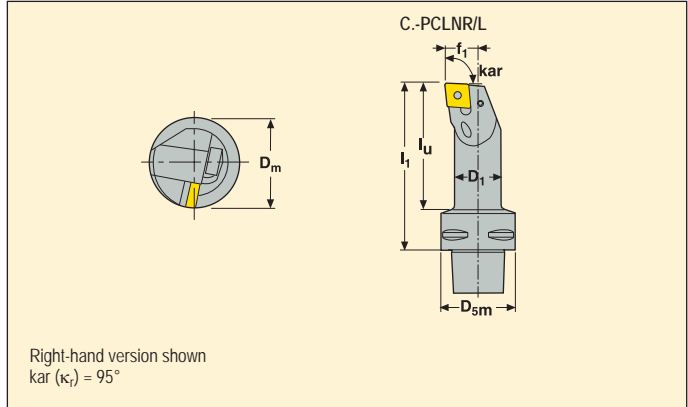

Capto size	Part No.	Dimensions in mm							γ_0°	λ_s°	KG	Key	
		D ₁	D _{5m}	f ₁	I ₁	I ₃	D _m min						
C4	12	C4-PCLNR -17090-12	25	40	17,0	90	69	32	-6	-11	0,5	CN..1204..	
		-22110-12	32	40	22,0	110	89	40	-6	-11	0,8	CN..1204..	
		-27080-12	40	40	27,0	80	60	50	-6	-10	0,7	CN..1204..	
		-27120-12	40	40	27,0	120	100	50	-6	-11	1,1	CN..1204..	
		C4-PCLNL -17090-12	25	40	17,0	90	69	32	-6	-11	0,5	CN..1204..	
		-22110-12	32	40	22,0	110	89	40	-6	-11	0,8	CN..1204..	
		-27080-12	40	40	27,0	80	60	50	-6	-10	0,7	CN..1204..	
		-27120-12	40	40	27,0	120	100	50	-6	-11	1,1	CN..1204..	
C5	12	C5-PCLNR -17090-12	25	50	17,0	90	67	32	-6	-11	0,7	CN..1204..	
		-22110-12	32	50	22,0	110	88	40	-6	-11	1,0	CN..1204..	
		-35100-12	50	50	35,0	100	81	50	-6	-7	1,4	CN..1204..	
		-27140-12	40	50	27,0	140	119	50	-6	-10	1,5	CN..1204..	
		C5-PCLNL -17090-12	25	50	17,0	90	67	32	-6	-11	0,7	CN..1204..	
		-22110-12	32	50	22,0	110	88	40	-6	-11	0,8	CN..1204..	
		-27140-12	40	50	27,0	140	119	50	-6	-10	1,5	CN..1204..	
			-35100-12	50	50	35,0	100	81	50	-6	-7	1,4	CN..1204..
		16	C5-PCLNR -35150-16	50	50	35,0	150	131	63	-6	-11	2,1	CN..1606..
			C5-PCLNL -35150-16	50	50	35,0	150	131	63	-6	-11	2,1	CN..1606..

Spare Parts, Parts included in delivery

For size	Insert lever	Insert shim	Lever key	Lever screw	Punch	Shim pin
17090-12	PP4613	-	2.5SMS795	LS0613	-	-
-12	PP4713	PCN120308	3SMS795	LS0818	MP0912	RP6757
-16	PP7818	PCN160408	3SMS795	LS0820	MP0912	RP8286

Please check availability in current price and stock-list

Toolholders for inserts CNGG, CNMA, CNMG and CNMM



- For insert programme, see page(s) 348-355, 402, 431
- γ_0° = Rake angle, λ_s° = Inclination angle
- For holder code key, see page(s) 12-13

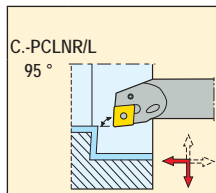
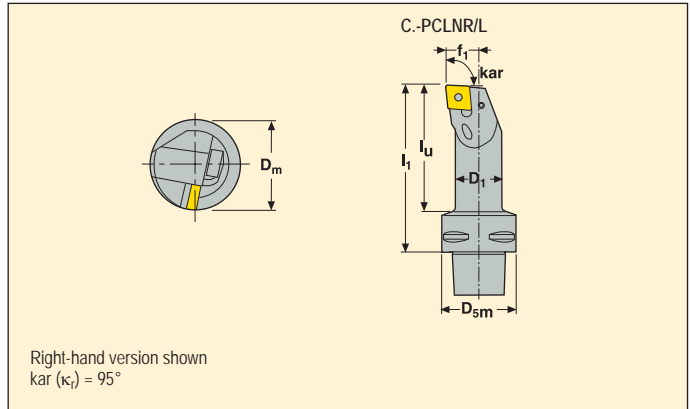

Capto size	Part No.	Dimensions in mm							γ_0°	λ_s°	KG	Insert
		D ₁	D _{5m}	f ₁	l ₁	l ₃	D _m min					
C6	12	C6-PCLNR -17100-12	25	63	17,0	100	74	32	-6	-11	1,1	CN..1204..
		-22110-12	32	63	22,0	110	84	40	-6	-11	1,3	CN..1204..
		C6-PCLNL -17100-12	25	63	17,0	100	74	32	-6	-11	1,1	CN..1204..
		-22110-12	32	63	22,0	110	84	40	-6	-11	1,3	CN..1204..
	16	C6-PCLNR -27140-16	40	63	27,0	140	115	50	-6	-11	1,8	CN..1606..
		-35175-16	50	63	35,0	175	152	63	-6	-11	2,8	CN..1606..
		C6-PCLNL -27140-16	40	63	27,0	140	115	50	-6	-11	1,8	CN..1606..
		-35175-16	50	63	35,0	175	152	63	-6	-11	2,8	CN..1606..

Spare Parts, Parts included in delivery

For size	Insert lever	Insert shim	Lever key	Lever screw	Punch	Shim pin
-17100-12	PP4613	-	2.5SMS795	LS0613	-	-
-22110-12	PP4713	PCN120308	3SMS795	LS0818	MP0912	RP6757
-16	PP7818	PCN160408	3SMS795	LS0820	MP0912	RP8286

Please check availability in current price and stock-list

Toolholders for inserts DCGT, DCGW, DCMT, DCMW and DCMX



- For insert programme, see page(s) 356-359, 404, 433
- γ_0° = Rake angle, λ_s° = Inclination angle
- For holder code key, see page(s) 12-13

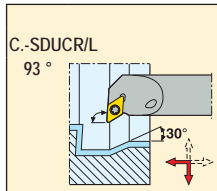
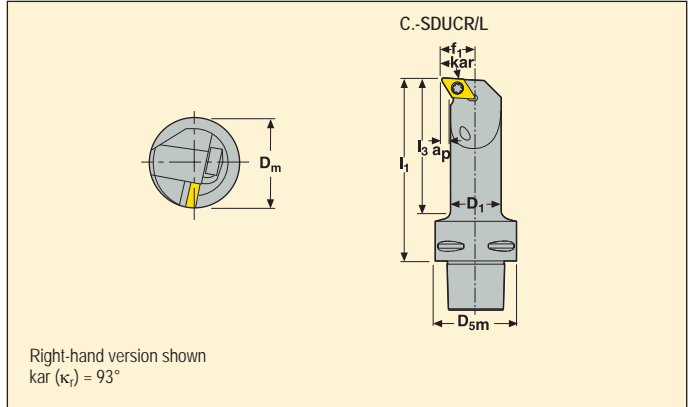

Capto size	Part No.	Dimensions in mm							D _m min	γ_0°	λ_s°	KG	Key
		D ₁	D _{5m}	f ₁	l ₁	l ₃	a _p						
C3	07	C3-SDUCR -11065-07	16	32	11,0	65	48	2,5	20	0	-8	0,2	DC..0702..
		C3-SDUCL -11065-07	16	32	11,0	65	48	2,5	20	0	-8	0,2	DC..0702..
	11	C3-SDUCR -13075-11	20	32	13,0	75	59	2,5	25	0	-8	0,3	DC..11T3..
		-17090-11	25	32	17,0	90	74	4,0	32	0	-6	0,4	DC..11T3..
		-22096-11	32	32	22,0	96	82	5,0	40	0	-6	0,6	DC..11T3..
		C3-SDUCL -13075-11	20	32	13,0	75	59	2,5	25	0	-8	0,3	DC..11T3..
-17090-11	25	32	17,0	90	74	4,0	32	0	-6	0,4	DC..11T3..		
-22096-11	32	32	22,0	96	82	5,0	40	0	-6	0,6	DC..11T3..		
C4	07	C4-SDUCR -11070-07	16	40	11,0	70	47	2,5	20	0	-8	0,4	DC..0702..
		C4-SDUCL -11070-07	16	40	11,0	70	47	2,5	20	0	-8	0,4	DC..0702..
	11	C4-SDUCR -13080-11	20	40	13,0	80	57	2,5	25	0	-8	0,4	DC..11T3..
		-17090-11	25	40	17,0	90	68	4,0	32	0	-6	0,5	DC..11T3..
		-22110-11	32	40	22,0	110	89	5,0	40	0	-6	0,8	DC..11T3..
		-27080-11	40	40	27,0	80	60	6,0	50	0	-6	0,7	DC..11T3..
		C4-SDUCL -13080-11	20	40	13,0	80	57	2,5	25	0	-8	0,4	DC..11T3..
		-17090-11	25	40	17,0	90	68	4,0	32	0	-6	0,5	DC..11T3..
	-22110-11	32	40	22,0	110	89	5,0	40	0	-6	0,8	DC..11T3..	
	-27080-11	40	40	27,0	80	60	6,0	50	0	-6	0,7	DC..11T3..	

Spare Parts, Parts included in delivery

For size	Insert key	Insert screw	Insert shim	Shim screw	Shim key
-07	T07P-2	C02506-T07P	-	-	-
-13...-11	T15P-2	C03508-T15P	-	-	-
-17...-11	T15P-2	C03510-T15P	-	-	-
-2...-11	T15P-2	C03512-T15P	126.19-620	CA3507	9/64SMS875

Accessories, to be ordered separately

Please check availability in current price and stock-list

Toolholders for inserts DCGT, DCGW, DCMT, DCMW and DCMX



- For insert programme, see page(s) 356-359, 404, 433
- γ_0° = Rake angle, λ_s° = Inclination angle
- For holder code key, see page(s) 12-13

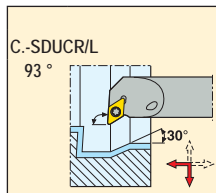
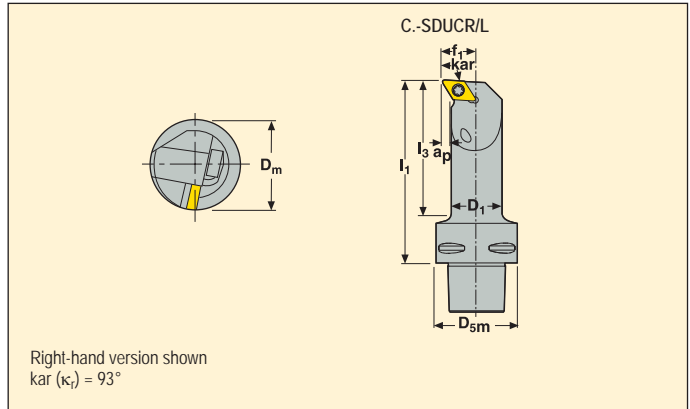

Capto size	Part No.	Dimensions in mm							γ_0°	λ_s°	KG	Key
		D ₁	D _{5m}	f ₁	I ₁	I ₃	a _p	D _m min				
C5	07 C5-SDUCR -11070-07	16	50	11,0	70	46	2,5	20	0	-8	0,5	DC..0702..
	C5-SDUCL -11070-07	16	50	11,0	70	46	2,5	20	0	-8	0,5	DC..0702..
	11 C5-SDUCR -13080-11	20	50	13,0	80	56	2,5	25	0	-8	0,6	DC..11T3..
	-17090-11	25	50	17,0	90	67	4,0	32	0	-6	0,7	DC..11T3..
	-22110-11	32	50	22,0	110	88	5,0	40	0	-6	0,9	DC..11T3..
	-35100-11	50	50	35,0	100	80	6,0	63	0	-4	1,4	DC..11T3..
	C5-SDUCL -13080-11	20	50	13,0	80	56	2,5	25	0	-8	0,6	DC..11T3..
	-17090-11	25	50	17,0	90	67	4,0	32	0	-6	0,7	DC..11T3..
	-22110-11	32	50	22,0	110	88	5,0	40	0	-6	0,9	DC..11T3..
	-35100-11	50	50	35,0	100	80	6,0	63	0	-4	1,4	DC..11T3..

Spare Parts, Parts included in delivery

For size	Insert key	Insert screw	Insert shim	Shim screw	Shim key
-07	T07P-2	C02506-T07P	-	-	-
-13...11	T15P-2	C03508-T15P	-	-	-
-17...11	T15P-2	C03510-T15P	-	-	-
-22/35...11	T15P-2	C03512-T15P	126.19-620	CA3507	9/64SMS875

Accessories, to be ordered separately

Please check availability in current price and stock-list

Toolholders for inserts DCGT, DCGW, DCMT and DCMW



- For insert programme, see page(s) 356-357, 404, 433
- γ_o° = Rake angle, λ_s° = Inclination angle
- For holder code key, see page(s) 12-13

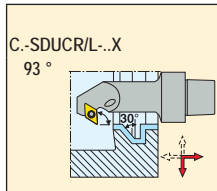
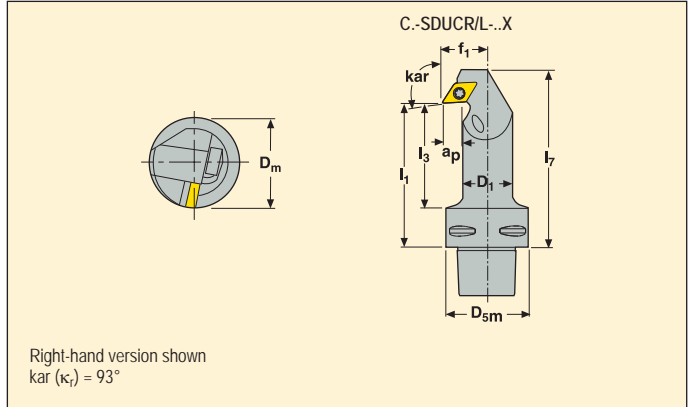

Capto size	Part No.	Dimensions in mm										γ_o°	λ_s°	KG	Insert Key
		D ₁	D _{5m}	f ₁	l ₁	l ₃	l ₇	a _p	D _m min						
C4	07	C4-SDUCL -13070-07X	16	40	13,0	70	47	-	4,0	22	0	-6	0,4	DC..0702..	
		-15080-07X	20	40	15,0	80	57	-	4,0	27	0	-3	0,4	DC..0702..	
		-18090-07X	25	40	18,0	90	68	-	4,5	32	0	-3	0,5	DC..0702..	
	C4-SDUCR	C4-SDUCR -13070-07X	16	40	13,0	70	47	-	4,0	22	0	-6	0,4	DC..0702..	
		-15080-07X	20	40	15,0	80	57	-	4,0	27	0	-3	0,4	DC..0702..	
		-18090-07X	25	40	18,0	90	68	-	4,5	32	0	-3	0,5	DC..0702..	
C5	07	C5-SDUCL -15080-07X	20	50	15,0	80	56	-	4,0	27	0	-3	0,6	DC..0702..	
		-18090-07X	25	50	18,0	90	67	-	4,5	32	0	-3	0,7	DC..0702..	
		C5-SDUCR -15080-07X	20	50	15,0	80	56	-	4,0	27	0	-3	0,6	DC..0702..	
		-18090-07X	25	50	18,0	90	67	-	4,5	32	0	-3	0,7	DC..0702..	

Spare Parts, Parts included in delivery

For size	Insert key	Insert screw
-07X	T07P-2	C02506-T07P

Please check availability in current price and stock-list

Toolholders for inserts DNGA, DNGM, DNMA, DNMG, DNMM and DNMX



- For insert programme, see page(s) 360-365, 406
- γ_0° = Rake angle, λ_s° = Inclination angle
- For holder code key, see page(s) 12-13

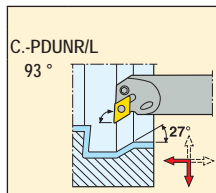
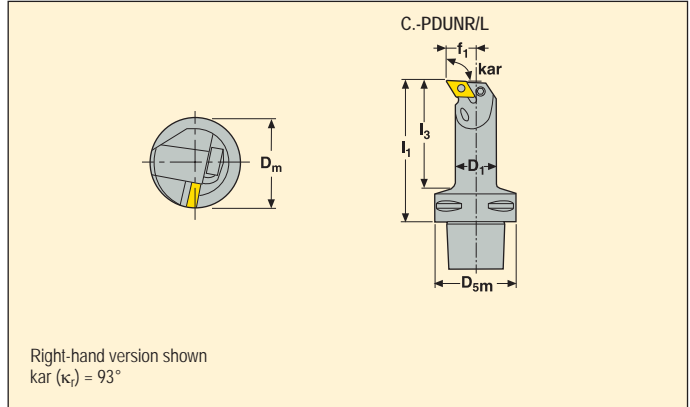

Capto size	Part No.	Dimensions in mm							γ_0°	λ_s°	KG	Key
		D ₁	D _{5m}	f ₁	l ₁	l ₃	D _m min					
C4	15 C4-PDUNR -27080-15	40	40	27,0	80	60	50	-6	-11	0,7	DN..1506..	
	-27120-15	40	40	27,0	120	100	50	-6	-11	1,1	DN..1506..	
	C4-PDUNL -27080-15	40	40	27,0	80	60	50	-6	-11	0,7	DN..1506..	
	-27120-15	40	40	27,0	120	100	50	-6	-11	1,1	DN..1506..	
C5	15 C5-PDUNR -27140-15	40	50	27,0	140	119	50	-6	-11	1,5	DN..1506..	
	-35100-15	50	50	35,0	100	81	63	-6	-10	1,4	DN..1506..	
	-35150-15	50	50	35,0	150	131	63	-6	-10	2,1	DN..1506..	
	C5-PDUNL -27140-15	40	50	27,0	140	119	50	-6	-11	1,5	DN..1506..	
	-35100-15	50	50	35,0	100	81	63	-6	-10	1,4	DN..1506..	
	-35150-15	50	50	35,0	150	131	63	-6	-10	2,1	DN..1506..	
C6	15 C6-PDUNR -22110-15	32	63	22,0	110	84	40	-6	-12	1,3	DN..1506..	
	-27140-15	40	63	27,0	140	115	50	-6	-11	1,8	DN..1506..	
	-35175-15	50	63	35,0	175	152	63	-6	-10	2,8	DN..1506..	
	C6-PDUNL -22110-15	32	63	22,0	110	84	40	-6	-12	1,3	DN..1506..	
	-27140-15	40	63	27,0	140	115	50	-6	-11	1,8	DN..1506..	
	-35175-15	50	63	35,0	175	152	63	-6	-10	2,8	DN..1506..	

Spare Parts, Parts included in delivery

For size	Insert lever	Insert shim	Lever key	Lever screw	Punch	Shim pin	Insert shim
-15	PP4716	PDN150308	3SMS795	LS0822	MP0912	RP6757	PDN150408

Accessories*

Please check availability in current price and stock-list

*To be ordered separately
Shim PDN150412 for inserts DN..1504.., to be ordered separately

Toolholders for inserts DNMA, DNMU and DNMX



- For insert programme, see page(s) 364-365, 407
- γ_0 = Rake angle, λ_s = Inclination angle
- For holder code key, see page(s) 12-13

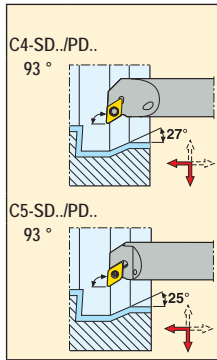
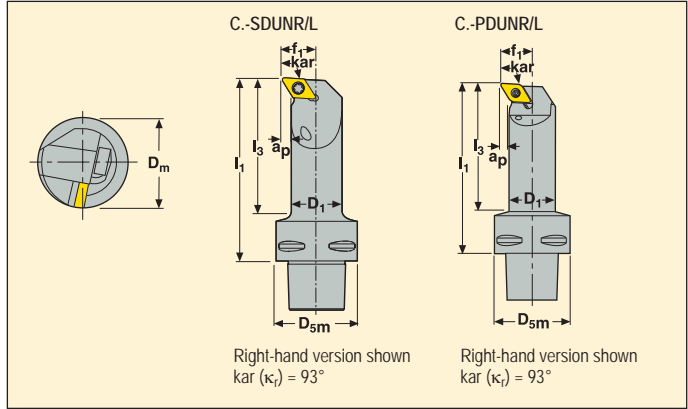

Capto size	Part No.	Dimensions in mm								γ_0	λ_s	KG	Key	
		D ₁	D _{5m}	f ₁	l ₁	l ₃	a _p	D _m min						
C4	11	C4-SDUNR -11065-11	16	40	11,0	65	41	2,5	20	-5	-17	0,3	DNMU/DNMX1104..	
		C4-SDUNR -13080-11	20	40	13,0	80	56	2,5	25	-5	-14	0,4	DNMU/DNMX1104..	
	C4-SDUNL	C4-SDUNL -11065-11	16	40	11,0	65	41	2,5	20	-5	-17	0,3	DNMU/DNMX1104..	
		C4-SDUNL -13080-11	20	40	13,0	80	56	2,5	25	-5	-14	0,4	DNMU/DNMX1104..	
	11	C4-PDUNR -17090-11	25	40	17,0	90	68	4,0	32	-5	-13	0,5	DN..1104..	
		C4-PDUNR -22110-11	32	40	22,0	110	89	5,0	40	-5	-11	0,7	DN..1104..	
C4-PDUNL		C4-PDUNL -17090-11	25	40	17,0	90	68	4,0	32	-5	-13	0,5	DN..1104..	
		C4-PDUNL -22110-11	32	40	22,0	110	89	5,0	40	-5	-11	0,7	DN..1104..	
C5	11	C5-SDUNR -13080-11	20	50	13,0	80	56	2,5	25	-5	-14	0,6	DNMU/DNMX1104..	
		C5-SDUNL -13080-11	20	50	13,0	80	56	2,5	25	-5	-14	0,6	DNMU/DNMX1104..	
	11	C5-PDUNR -17090-11	25	50	17,0	90	67	4,0	32	-5	-13	0,7	DN..1104..	
		C5-PDUNR -22110-11	32	50	22,0	110	89	5,0	40	-5	-11	0,9	DN..1104..	
		C5-PDUNL	C5-PDUNL -17090-11	25	50	17,0	90	67	4,0	32	-5	-13	0,7	DN..1104..
			C5-PDUNL -22110-11	32	50	22,0	110	89	5,0	40	-5	-11	0,9	DN..1104..

Spare Parts, Parts included in delivery

For size	Insert key	Insert pin	Insert screw	Insert shim	Shim screw	Shim key
-11...-11	T09P-2	-	C03511-T09P	-	-	-
-13...-11	T09P-2	-	C03511-T09P	DAI110212	CA3507	9/64SMS875
-17/22...-11	T09P-2	PL1403-T09P	-	DAE110312	-	-

Accessories*

Please check availability in current price and stock-list

*To be ordered separately

Toolholders for inserts DNMA and DNMU



- For insert programme, see page(s) 364, 407
- γ_0° = Rake angle, λ_s° = Inclination angle
- For holder code key, see page(s) 12-13

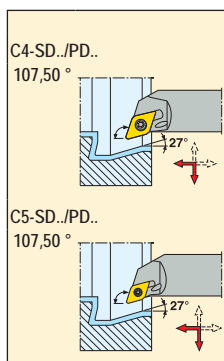
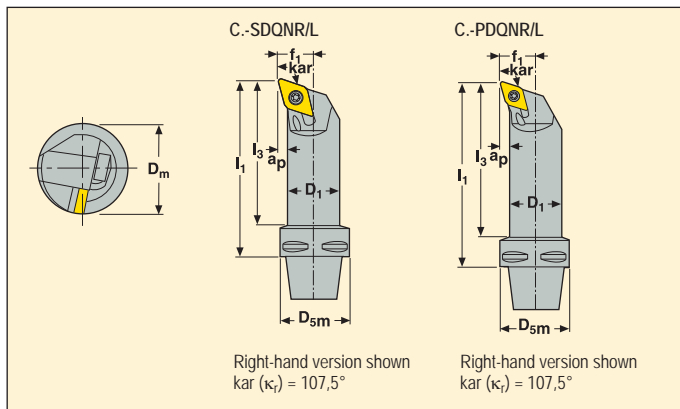

Capto size	Part No.	Dimensions in mm							γ_0°	λ_s°	KG	Insert	
		D ₁	D _{5m}	f ₁	l ₁	l ₃	a _p	D _m min					
C4	11	C4-SDQNR -11065-11	16	40	11,0	65	41	2,5	20	-5	-17	0,4	DNMU1104..
		-13080-11	20	40	13,0	80	56	2,5	25	-5	-17	0,4	DNMU1104..
	C4-SDQNL -11065-11	16	40	11,0	65	41	2,5	20	-5	-17	0,4	DNMU1104..	
		-13080-11	20	40	13,0	80	56	2,5	25	-5	-17	0,4	DNMU1104..
	11	C4-PDQNR -17090-11	25	40	17,0	90	68	4,0	32	-5	-16	0,5	DN..1104..
		-22110-11	32	40	22,0	110	89	5,0	40	-5	-14	0,7	DN..1104..
C4-PDQNL -17090-11		25	40	17,0	90	68	4,0	32	-5	-16	0,5	DN..1104..	
-22110-11		32	40	22,0	110	89	5,0	40	-5	-14	0,7	DN..1104..	
C5	11	C5-SDQNR -13080-11	20	50	13,0	80	56	2,5	25	-5	-18	0,6	DNMU1104..
		C5-SDQNL -13080-11	20	50	13,0	80	56	2,5	25	-5	-18	0,6	DNMU1104..
	11	C5-PDQNR -17090-11	25	50	17,0	90	67	4,0	32	-5	-16	0,7	DN..1104..
		-22110-11	32	50	22,0	110	89	5,0	40	-5	-14	0,9	DN..1104..
		C5-PDQNL -17090-11	25	50	17,0	90	67	4,0	32	-5	-16	0,7	DN..1104..
		-22110-11	32	50	22,0	110	89	5,0	40	-5	-14	0,9	DN..1104..

Spare Parts, Parts included in delivery

For size	Insert key	Insert pin	Insert screw	Insert shim	Shim screw	Shim key
-11....-11	T09P-2	-	C03511-T09P	-	-	-
-13....-11	T09P-2	-	C03511-T09P	DAI110212	CA3507	9/64SMS875
-17/22....-11	T09P-2	PL1403-T09P	-	DAE110312	-	-

Accessories*

Please check availability in current price and stock-list

*To be ordered separately

Toolholders for inserts SCGW and SCMT



- For insert programme, see page(s) 372, 412
- γ_o° = Rake angle, λ_s° = Inclination angle
- For holder code key, see page(s) 12-13

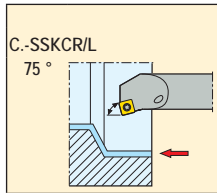
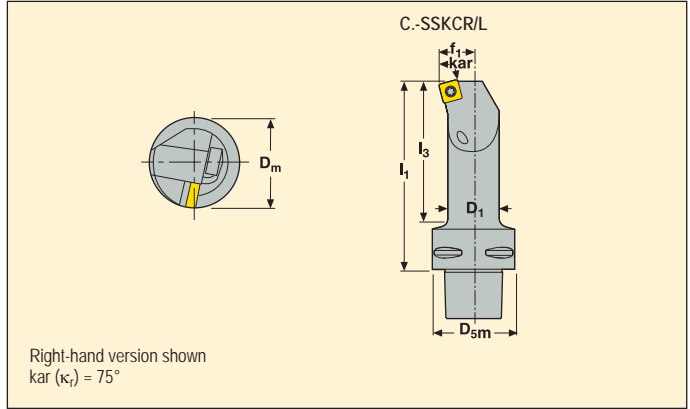

Capto size	Part No.	Dimensions in mm							γ_o°	λ_s°	KG	Key
		D ₁	D _{5m}	f ₁	L ₁	L ₃	D _m min					
C5	09 C5-SSKCR -13080-09	20	50	13,0	80	56	25	0	-6	0,6	SC..09T3..	
	C5-SSKCL -13080-09	20	50	13,0	80	56	25	0	-6	0,6	SC..09T3..	

Spare Parts, Parts included in delivery

For size	Insert key	Insert screw
-09	T15P-2	C03508-T15P

Please check availability in current price and stock-list

Toolholders for inserts TCGT, TCMT and TCMW



- For insert programme, see page(s) 380-382, 419, 434
- γ_0° = Rake angle, λ_s° = Inclination angle
- For holder code key, see page(s) 12-13

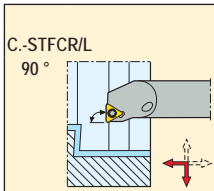
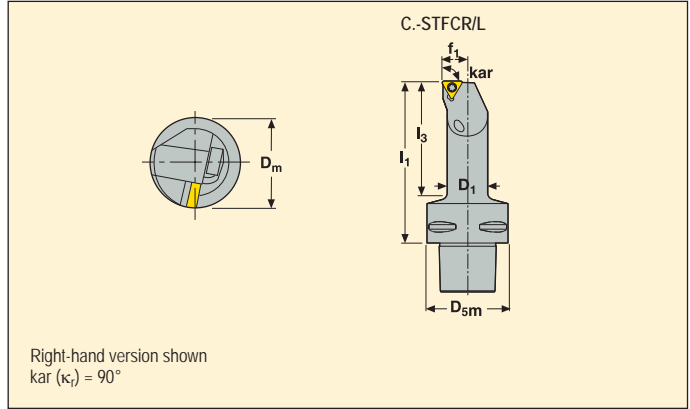

Capto size	Part No.	Dimensions in mm							γ_0°	λ_s°	KG	Key
		D ₁	D _{5m}	f ₁	l ₁	l ₃	D _m min					
C3	11 C3-STFCR -11065-11	16	32	11,0	65	48	20	0	-4	0,2	TC..1102..	
	C3-STFCL -11065-11	16	32	11,0	65	48	20	0	-4	0,2	TC..1102..	
C4	11 C4-STFCR -11070-11	16	40	11,0	70	47	20	0	-4	0,4	TC..1102..	
	-13080-11	20	40	13,0	80	57	25	0	-3	0,4	TC..1102..	
	C4-STFCL -11070-11	16	40	11,0	70	47	20	0	-4	0,4	TC..1102..	
	16 C4-STFCR -17090-16	25	40	17,0	90	68	32	0	-6	0,5	TC..16T3..	
	-22110-16	32	40	22,0	110	89	40	0	-10	0,8	TC..16T3..	
	C4-STFCL -17090-16	25	40	17,0	90	68	32	0	-6	0,5	TC..16T3..	
	-22110-16	32	40	22,0	110	89	40	0	-10	0,8	TC..16T3..	

Spare Parts, Parts included in delivery

For size	Insert key	Insert screw	Insert shim	Shim screw	Shim key
-11	T07P-2	C02506-T07P	-	-	-
-17...16	T15P-2	C03509-T15P	-	-	-
-22...16	T15P-2	C03509-T15P	STN160312	CA3510	9/64SMS875

Accessories, to be ordered separately

Please check availability in current price and stock-list

Toolholders for inserts TCGT, TCMT and TCMW



- For insert programme, see page(s) 380-382, 419, 434
- γ_0° = Rake angle, λ_s° = Inclination angle
- For holder code key, see page(s) 12-13

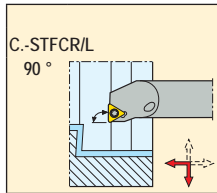
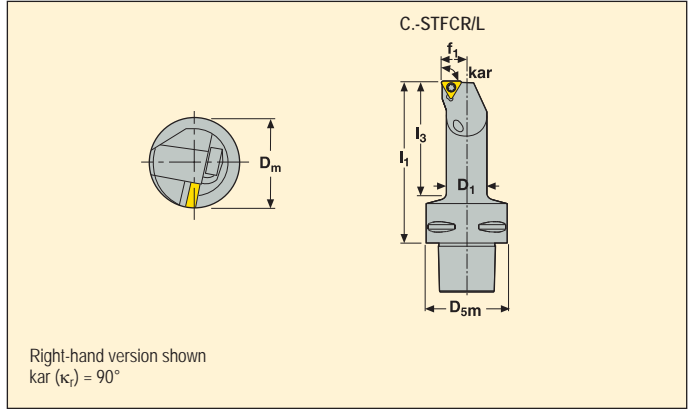

Capto size	Part No.	Dimensions in mm							γ_0°	λ_s°	KG	Warning symbol
		D ₁	D _{5m}	f ₁	l ₁	l ₃	D _m min					
C5	11	C5-STFCR -11070-11	16	50	11,0	70	46	40	0	-4	0,6	TC..1102..
		C5-STFCR -13080-11	20	50	13,0	80	56	25	0	-3	0,6	TC..1102..
		C5-STFCL -11070-11	16	50	11,0	70	46	20	0	-4	0,6	TC..1102..
		C5-STFCL -13080-11	20	50	13,0	80	56	25	0	-3	0,6	TC..1102..
	16	C5-STFCR -17090-16	25	50	17,0	90	67	32	0	-6	0,7	TC..16T3..
		C5-STFCR -22110-16	32	50	22,0	110	88	40	0	-10	1,0	TC..16T3..
		C5-STFCL -17090-16	25	50	17,0	90	67	32	0	-6	0,7	TC..16T3..
		C5-STFCL -22110-16	32	50	22,0	110	88	40	0	-10	1,0	TC..16T3..

Spare Parts, Parts included in delivery

For size	Insert key	Insert screw	Insert shim	Shim screw	Shim key
-11	T07P-2	C02506-T07P	-	-	-
-17090-16	T15P-2	C03509-T15P	-	-	-
-22110-16	T15P-2	C03509-T15P	STN160312	CA3510	9/64SMS875

Accessories, to be ordered separately

Please check availability in current price and stock-list

Toolholders for inserts TNGA, TNMA, TNMG and TNMM



- For insert programme, see page(s) 385-389, 420
- γ_0° = Rake angle, λ_s° = Inclination angle
- For holder code key, see page(s) 12-13

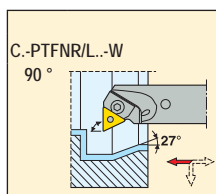
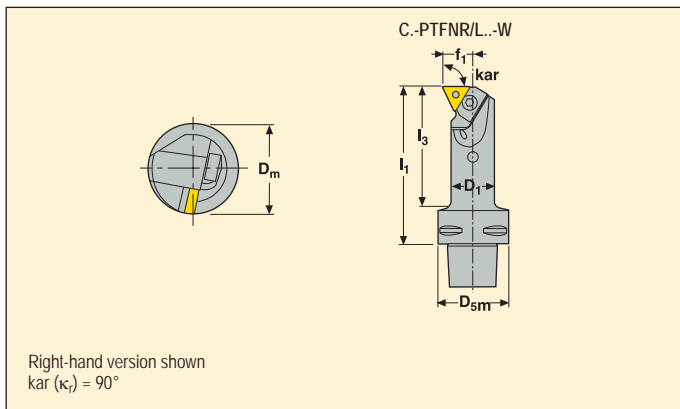

Capto size	Part No.	Dimensions in mm							γ_0°	λ_s°	KG	Key
		D ₁	D _{5m}	f ₁	l ₁	l ₃	D _m min					
C4	16	C4-PTFNR -17090-16-W	25	40	17,0	90	69	32	-6	-13	0,5	TN..1604..
		-27120-16-W	40	40	27,0	120	100	50	-6	-11	1,1	TN..1604..
	C4-PTFNL -17090-16-W	25	40	17,0	90	69	32	-6	-13	0,5	TN..1604..	
		-27120-16-W	40	40	27,0	120	100	50	-6	-11	1,1	TN..1604..
C5	16	C5-PTFNR -22110-16-W	32	40	22,0	110	88	40	-6	-12	0,9	TN..1604..
		-27140-16-W	40	40	27,0	140	119	50	-6	-11	1,5	TN..1604..
	C5-PTFNL -22110-16-W	32	40	22,0	110	88	40	-6	-12	0,9	TN..1604..	
		-27140-16-W	40	40	27,0	140	119	50	-6	-11	1,5	TN..1604..
C6	16	C6-PTFNR -22110-16-W	32	63	22,0	110	84	40	-6	-12	1,3	TN..1604..
		-27140-16-W	40	63	27,0	140	115	50	-6	-11	1,8	TN..1604..
		C6-PTFNL -22110-16-W	32	63	22,0	110	84	40	-6	-12	1,3	TN..1604..
			-27140-16-W	40	63	27,0	140	115	50	-6	-11	1,8
	22	C6-PTFNR -35175-22-W	50	63	35,0	175	152	63	-6	-10	2,8	TN..2204..
		C6-PTFNL -27140-22-W	40	63	27,0	140	115	50	-6	-11	1,8	TN..2204..
			-35175-22-W	50	63	35,0	175	152	63	-6	-10	2,8

Spare Parts, Parts included in delivery

For size	Insert shim	Setting screw	Shim pin	Wedge clamp	Wedge key	Shim key
-17....16	-	F83060-T09P	PL1003	CP16-H31	3SMS795	T09P-2
-22/27....16	PTN160308	F83060-T09P	PL1203	CP16-H3	3SMS795	T09P-2
-22	PTN220410	F84060-T15P	PL1405	CP22-H4	4SMS795	T09P-2

Accessories*

Please check availability in current price and stock-list

*To be ordered separately

Toolholders for PCBN inserts TNGN, TNGX, TNMN and TNMX



- For insert programme, see page(s) 421-425
- γ_0° = Rake angle, λ_s° = Inclination angle
- For holder code key, see page(s) 12-13

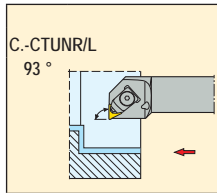
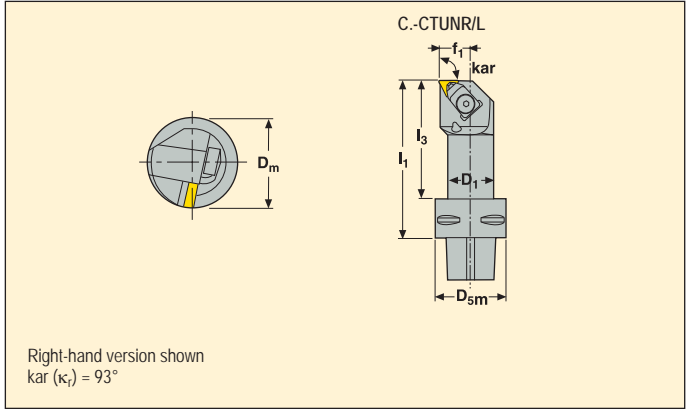

Capto size	Part No.	Dimensions in mm							γ_0°	λ_s°	KG	Warning
		D ₁	D _{5m}	f ₁	l ₁	l ₃	D _m min					
C4	11	C4-CTUNR -17090-11	25	40	17,0	90	68	32	-6	-12	0,6	TN..1103..
		-22110-11	32	40	22,0	110	88	40	-6	-12	0,8	TN..1103..
	C4-CTUNL	-17090-11	25	40	17,0	90	68	32	-6	-12	0,6	TN..1103..
		-22110-11	32	40	22,0	110	88	40	-6	-12	0,8	TN..1103..
C5	11	C5-CTUNR -17090-11	25	50	17,0	90	67	32	-6	-12	1,0	TN..1103..
		-22110-11	32	50	22,0	110	89	40	-6	-12	1,0	TN..1103..
	C5-CTUNL	-17090-11	25	50	17,0	90	67	32	-6	-12	1,0	TN..1103..
		-22110-11	32	50	22,0	110	89	40	-6	-12	1,0	TN..1103..
C6	11	C6-CTUNR -22110-11	32	63	22,0	110	89	40	-6	-12	1,3	TN..1103..
		C6-CTUNL -22110-11	32	63	22,0	110	89	40	-6	-12	1,3	TN..1103..

Spare Parts, Parts included in delivery

For size	Cantilever clamp	Clamp key	Insert shim	Shim screw	Shim key
-11	CC14	4SMS795	CTN110308	CS2507-T07P	T07P-2

Accessories, to be ordered separately

Please check availability in current price and stock-list

Toolholders for inserts VBGW, VBMT, VBMW and VCGT



- For insert programme, see page(s) 390-392, 426, 435
- γ_0° = Rake angle, λ_s° = Inclination angle
- For holder code key, see page(s) 12-13

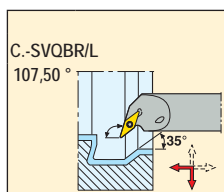
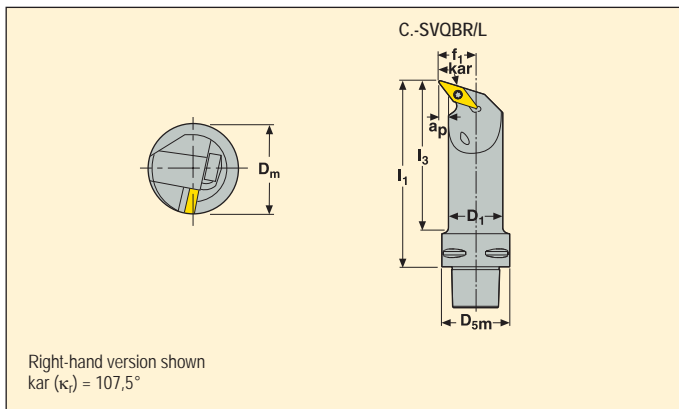

Capto size	Part No.	Dimensions in mm							D _m min	γ ₀ °	λ _s °	KG	Key
		D ₁	D _{5m}	f ₁	l ₁	l ₃	a _p	D _m					
C3	11 C3-SVOBR -13070-11	16	32	13,0	70	53	4,0	22	0	-7	0,2	VB..1102..	
	-15080-11	20	32	15,0	80	64	4,0	27	0	-5	0,3	VB..1102..	
	C3-SVOBL -13070-11	16	32	13,0	70	53	4,0	22	0	-7	0,2	VB..1102..	
	-15080-11	20	32	15,0	80	64	4,0	27	0	-5	0,3	VB..1102..	
C4	11 C4-SVOBR -13070-11	16	40	13,0	70	47	4,0	25	0	-7	0,3	VB..1102..	
	-15080-11	20	40	15,0	80	58	4,0	27	0	-5	0,4	VB..1102..	
	C4-SVOBL -13070-11	16	40	13,0	70	47	4,0	25	0	-7	0,3	VB..1102..	
	-15080-11	20	40	15,0	80	58	4,0	27	0	-5	0,4	VB..1102..	
	16 C4-SVOBR -22110-16	32	40	22,0	110	89	5,0	40	0	-8	0,7	VB../VC..1604..	
	-27080-16	40	40	27,0	80	60	5,0	50	0	-8	0,7	VB../VC..1604..	
	-27120-16	40	40	27,0	120	100	6,0	50	0	-8	1,1	VB../VC..1604..	
	C4-SVOBL -18090-16	25	40	18,0	90	68	4,5	33	0	-6	0,5	VB../VC..1604..	
	-22110-16	32	40	22,0	110	89	5,0	40	0	-8	0,7	VB../VC..1604..	
	-27080-16	40	40	27,0	80	60	5,0	50	0	-8	0,7	VB../VC..1604..	
	-27120-16	40	40	27,0	120	100	6,0	50	0	-8	1,1	VB../VC..1604..	

Spare Parts, Parts included in delivery

Accessories, to be ordered separately

For size	Insert key	Insert screw	Insert shim	Shim screw	Shim key
-11	T07P-2	C02506-T07P	-	-	-
-18...16	T15P-2	C03510-T15P	-	-	-
-22/27...16	T15P-2	C03512-T15P	171.19-620	CA3507	9/64SMS875

Please check availability in current price and stock-list

Toolholders for inserts VBGW, VBMT, VBMW and VCGT



- For insert programme, see page(s) 390-392, 426, 435
- γ_0° = Rake angle, λ_s° = Inclination angle
- For holder code key, see page(s) 12-13

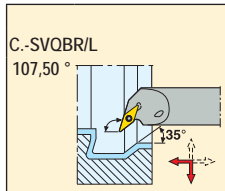
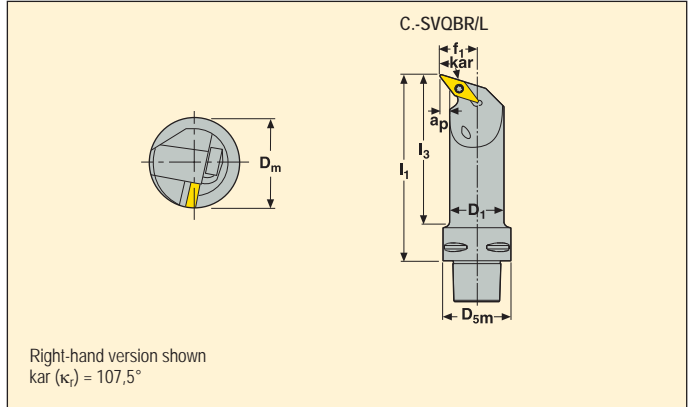

Capto size	Part No.	Dimensions in mm										KG	Insert
		D ₁	D _{5m}	f ₁	l ₁	l ₃	a _p	D _m min	γ_0°	λ_s°			
C5	11 C5-SVQBR -15080-11	20	50	15,0	80	57	4,0	27	0	-5	0,5	VB..1102..	
	C5-SVQBL -15080-11	20	50	15,0	80	57	4,0	27	0	-5	0,5	VB..1102..	
	16 C5-SVQBR -18090-16	25	50	18,0	90	67	4,5	33	0	-6	0,7	VB../VC..1604..	
	-22110-16	32	50	22,0	110	88	5,0	40	0	-8	0,9	VB../VC..1604..	
	-27140-16	40	50	27,0	140	119	6,0	50	0	-8	1,4	VB../VC..1604..	
	-35100-16	50	50	35,0	100	80	9,0	63	0	-7	1,3	VB../VC..1604..	
	-35150-16	50	50	35,0	150	130	9,0	63	0	-7	1,9	VB../VC..1604..	
	C5-SVQBL -18090-16	25	50	18,0	90	67	4,5	33	0	-6	0,7	VB../VC..1604..	
	-22110-16	32	50	22,0	110	88	5,0	40	0	-8	0,9	VB../VC..1604..	
	-27140-16	40	50	27,0	140	119	6,0	50	0	-8	1,4	VB../VC..1604..	
	-35100-16	50	50	35,0	100	80	9,0	63	0	-7	1,3	VB../VC..1604..	
	-35150-16	50	50	35,0	150	130	9,0	63	0	-7	1,9	VB../VC..1604..	
	C6	16 C6-SVQBR -22120-16	32	63	22,0	120	94	5,0	40	0	-8	1,3	VB../VC..1604..
		-27145-16	40	63	27,0	145	120	6,0	50	0	-8	1,9	VB../VC..1604..
-35175-16		50	63	35,0	175	152	9,0	63	0	-8	2,7	VB../VC..1604..	
C6-SVQBL -22120-16		32	63	22,0	120	94	5,0	40	0	-8	1,3	VB../VC..1604..	
-27145-16		40	63	27,0	145	120	6,0	50	0	-8	1,9	VB../VC..1604..	
-35175-16		50	63	35,0	175	152	9,0	63	0	-8	2,7	VB../VC..1604..	

Spare Parts, Parts included in delivery

For size	Insert key	Insert screw	Insert shim	Shim screw	Shim key
-11	T07P-2	C02506-T07P	-	-	-
-1...-16	T15P-2	C03510-T15P	-	-	-
-2/3...-16	T15P-2	C03512-T15P	171.19-620	CA3507	9/64SMS875

Accessories, to be ordered separately

Please check availability in current price and stock-list

Toolholders for inserts VNGA, VNGG, VNGM, VNMA, VNMG and VNMU



- For insert programme, see page(s) 393-394, 427-428
- γ_0° = Rake angle, λ_s° = Inclination angle
- For holder code key, see page(s) 12-13

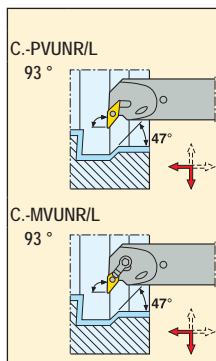
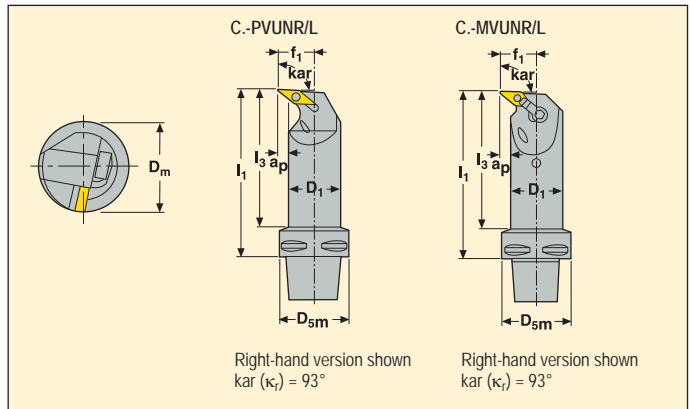

Capto size	Part No.	Dimensions in mm										γ_0°	λ_s°	KG	Key
		D1	D5m	f1	I1	I3	ap	Dm min							
C4	13	C4-PVUNR -17090-13	25	40	17,0	90	68	4,0	32	-5	-14	0,5		VN..1304..	
		-22110-13	32	40	22,0	110	90	5,0	40	-5	-12	0,7		VN..1304..	
		C4-PVUNL -17090-13	25	40	17,0	90	68	4,0	32	-5	-14	0,5		VN..1304..	
		-22110-13	32	40	22,0	110	90	5,0	40	-5	-12	0,7		VN..1304..	
	16	C4-MVUNR -22110-16	32	40	22,0	110	90	5,0	40	-5	-12	0,7		VN..1604..	
		-27120-16	40	40	27,0	120	100	6,0	50	-5	-10	1,1		VN..1604..	
		C4-MVUNL -22110-16	32	40	22,0	110	90	5,0	40	-5	-12	0,7		VN..1604..	
		-27120-16	40	40	27,0	120	100	6,0	50	-5	-10	1,1		VN..1604..	
C5	13	C5-PVUNR -22110-13	32	50	22,0	110	89	5,0	40	-5	-12	0,9		VN..1304..	
		C5-PVUNL -22110-13	32	50	22,0	110	89	5,0	40	-5	-12	0,9		VN..1304..	
	16	C5-MVUNR -22110-16	32	50	22,0	110	89	5,0	40	-5	-12	0,9		VN..1604..	
		-27140-16	40	50	27,0	140	119	6,0	50	-5	-10	1,4		VN..1604..	
		C5-MVUNL -22110-16	32	50	22,0	110	89	5,0	40	-5	-12	0,9		VN..1604..	
		-27140-16	40	50	27,0	140	119	6,0	50	-5	-10	1,4		VN..1604..	
	C6	16	C6-MVUNR -22120-16	32	63	22,0	120	88	5,0	40	-5	-12	1,3		VN..1604..
			-27145-16	40	63	27,0	145	120	6,0	50	-5	-10	1,8		VN..1604..
C6-MVUNL -22120-16			32	63	22,0	120	88	5,0	40	-5	-12	1,3		VN..1604..	
-27145-16			40	63	27,0	145	120	6,0	50	-5	-10	1,8		VN..1604..	

Spare Parts, Parts included in delivery

For size	Cantilever clamp	Clamp screw	Insert key	Insert pin	Insert shim	Shim/clamp key	Shim pin
-13	-	-	T09P-2	PL1403-T09P	PVN130308	-	-
-16	MC20	LD6021-T09P	-	-	VSN160316	T09P-2	MN0909L-T09P

Please check availability in current price and stock-list

Toolholders for inserts WCMT



- For insert programme, see page(s) 395
- γ_0° = Rake angle, λ_s° = Inclination angle
- For holder code key, see page(s) 12-13

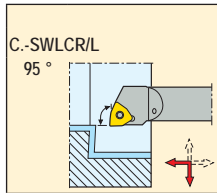
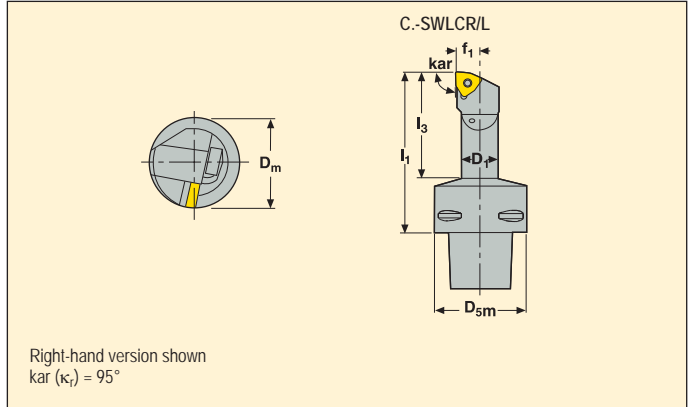

Capto size	Part No.	Dimensions in mm						γ_0°	λ_s°	KG	Insert	
		D ₁	D _{5m}	f ₁	l ₁	l ₃	D _m min					
C4	06	C4-SWLCR -11070-06	16	40	11,0	70	47	20	0	-5	0,4	WC..06T3..
		-13080-06	20	40	13,0	80	57	25	0	-5	0,4	WC..06T3..
		C4-SWLCCL -11070-06	16	40	11,0	70	47	20	0	-5	0,4	WC..06T3..
		-13080-06	20	40	13,0	80	57	25	0	-5	0,5	WC..06T3..
C5	06	C5-SWLCR -11070-06	16	50	11,0	70	46	20	0	-5	0,5	WC..06T3..
		-13080-06	20	50	13,0	80	56	25	0	-5	0,9	WC..06T3..
		C5-SWLCCL -11070-06	16	50	11,0	70	46	20	0	-5	0,5	WC..06T3..
		-13080-06	20	50	13,0	80	56	25	0	-5	0,9	WC..06T3..

Spare Parts, Parts included in delivery

For size	Insert key	Insert screw
C4-	T15P-2	C03510-T15P
C5-	T15P-2	C03508-T15P

Please check availability in current price and stock-list

Toolholders for inserts WNGA, WNGG, WNMA, WNMG and WNMM



- For insert programme, see page(s) 396-399, 429
- γ_0° = Rake angle, λ_s° = Inclination angle
- For holder code key, see page(s) 12-13

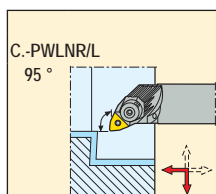
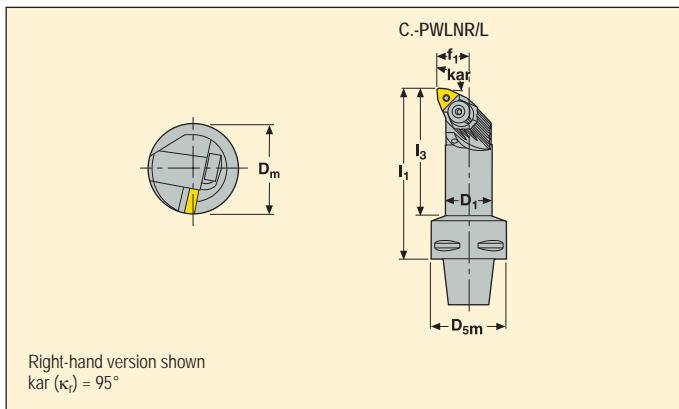

Capto size	Part No.	Dimensions in mm							γ_0°	λ_s°	KG	Key
		D1	D5m	f1	I1	I3	Dm min					
C4	C4-PWLNR -13080-06	20	40	13,0	80	57	25	-5	-11	0,4	WN..0604..	
	-17090-06	25	40	17,0	90	68	32	-5	-12	0,5	WN..0604..	
	-22110-06	32	40	22,0	110	89	40	-5	-12	0,7	WN..0604..	
	C4-PWLNL -13080-06	20	40	13,0	80	57	25	-5	-11	0,4	WN..0604..	
	-17090-06	25	40	17,0	90	68	32	-5	-12	0,5	WN..0604..	
	-22110-06	32	40	22,0	110	89	40	-5	-12	0,7	WN..0604..	
08	C4-PWLNR -22110-08	32	40	22,0	110	89	40	-5	-11	0,7	WN..0804..	
	-27120-08	40	40	27,0	120	100	50	-5	-8	1,0	WN..0804..	
	C4-PWLNL -22110-08	32	40	22,0	110	89	40	-5	-11	0,7	WN..0804..	
	-27120-08	40	40	27,0	120	100	50	-5	-8	1,0	WN..0804..	

Spare Parts, Parts included in delivery

For size	Insert shim	Setting screw	Shim pin	Wedge clamp	Wedge key	Wedge screw
-13/17...-06	WAI060212	L82511-T07P	PP1209-T09P	WNW06HD	T20P-7	WS1920-T20P
-22...-06	WAE060312	L82511-T07P	PP1409-T09P	WNW06HD	T20P-7	WS1920-T20P
-08	WAI080312	L82511-T07P	PP1415-T15P	WNW08HD	T25P-7	WS2325-T25P

Accessories*

Shim key
T09P-2
T09P-2
T15P-2

Please check availability in current price and stock-list

*To be ordered separately

Toolholders for inserts WNGA, WNGG, WNMA, WNMG and WNMM



- For insert programme, see page(s) 396-399, 429
- γ_0° = Rake angle, λ_s° = Inclination angle
- For holder code key, see page(s) 12-13

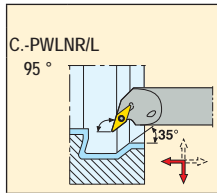
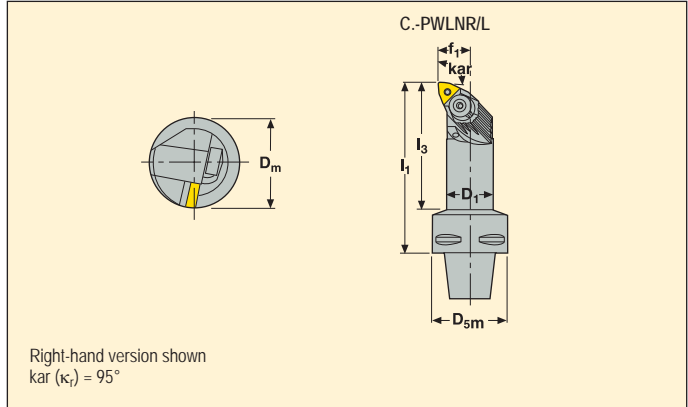

Capto size	Part No.	Dimensions in mm							γ_0°	λ_s°	KG	Key
		D ₁	D _{5m}	f ₁	l ₁	l ₃	D _m min					
C5	C5-PWLNLR -13080-06	20	50	13,0	80	56	25	-5	-11	0,6	WN..0604..	
	-17090-06	25	50	17,0	90	67	32	-5	-12	0,7	WN..0604..	
	-22110-06	32	50	22,0	110	88	40	-5	-12	0,9	WN..0604..	
	C5-PWLNLR -13080-06	20	50	13,0	80	56	25	-5	-11	0,6	WN..0604..	
	-17090-06	25	50	17,0	90	67	32	-5	-12	0,7	WN..0604..	
	-22110-06	32	50	22,0	110	88	40	-5	-12	0,9	WN..0604..	
C5	C5-PWLNLR -22110-08	32	50	22,0	110	88	40	-5	-11	0,9	WN..0804..	
	-27140-08	40	50	27,0	140	119	50	-5	-11	1,4	WN..0804..	
	C5-PWLNLR -22110-08	32	50	22,0	110	88	40	-5	-11	0,9	WN..0804..	
	-27140-08	40	50	27,0	140	119	50	-5	-11	1,4	WN..0804..	
C6	C6-PWLNLR -27140-08	40	63	27,0	140	115	50	-5	-8	1,7	WN..0804..	
	-35175-08	50	63	35,0	175	152	63	-5	-10	2,6	WN..0804..	
	C6-PWLNLR -27140-08	40	63	27,0	140	115	50	-5	-8	1,7	WN..0804..	
	-35175-08	50	63	35,0	175	152	63	-5	10	2,6	WN..0804..	

Spare Parts, Parts included in delivery

For size	Insert shim	Setting screw	Shim pin	Wedge clamp	Wedge key	Wedge screw	Shim key
-1...-06	WAI060212	L82511-T07P	PP1209-T09P	WNW06HD	T20P-7	WS1920-T20P	T09P-2
-2...-06	WAE060312	L82511-T07P	PP1409-T09P	WNW06HD	T20P-7	WS1920-T20P	T09P-2
-08	WAI080312	L82511-T07P	PP1415-T15P	WNW08HD	T25P-7	WS2325-T25P	T15P-2

Accessories*

Please check availability in current price and stock-list

*To be ordered separately

Toolholders for inserts CCGT, CCGW, CCMT and CCMW

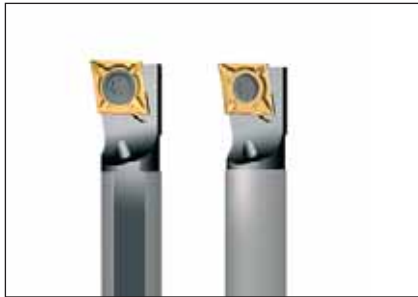

- For insert programme, see page(s) 343-347, 400-401, 431-432
- γ_0° = Rake angle, λ_s° = Inclination angle
- For holder code key, see page(s) 16-17

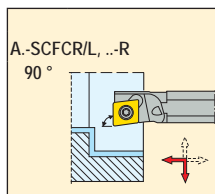
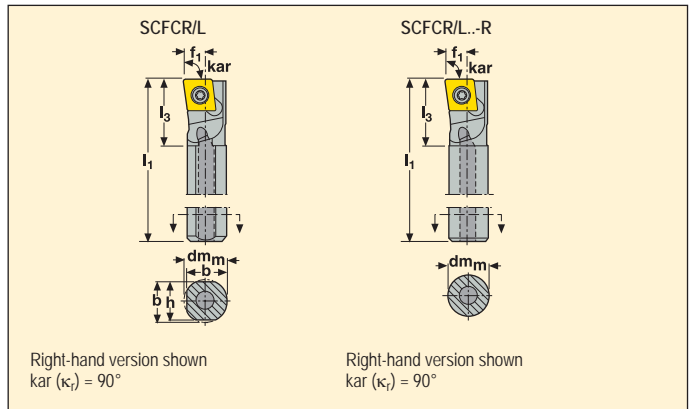

	Part No.	Dimensions in mm							γ_0°	λ_s°	KG	
		dm _m	h	b	l ₁	f ₁	l ₃	D _m min				
06	A08K-SCFCR06	8	7	7,5	125	5	12	10	0	-11	0,1	CC..0602..
	A08K-SCFCR06-R	8	-	-	125	5	12	10	0	-11	0,1	CC..0602..
	A10L-SCFCR06	10	9	9,5	140	7	18	13	0	-11	0,1	CC..0602..
	A10L-SCFCR06-R	10	-	-	140	7	18	13	0	-11	0,1	CC..0602..
	A08K-SCFCL06	8	7	7,5	125	5	12	10	0	-11	0,1	CC..0602..
	A08K-SCFCL06-R	8	-	-	125	5	12	10	0	-11	0,1	CC..0602..
	A10L-SCFCL06	10	9	9,5	140	7	18	13	0	-11	0,1	CC..0602..
A10L-SCFCL06-R	10	-	-	140	7	18	13	0	-11	0,1	CC..0602..	
09	A12N-SCFCR09	12	11	11,5	160	9	20	17	0	-11	0,2	CC..09T3..
	A12N-SCFCR09-R	12	-	-	160	9	20	17	0	-11	0,2	CC..09T3..
	A16Q-SCFCR09	16	15	15,5	180	11	22	22	0	-5	0,3	CC..09T3..
	A16Q-SCFCR09-R	16	-	-	180	11	22	22	0	-5	0,3	CC..09T3..
	A20R-SCFCR09	20	18	19,0	200	13	32	25	0	-5	0,4	CC..09T3..
	A20R-SCFCR09-R	20	-	-	200	13	32	25	0	-5	0,4	CC..09T3..
	A12N-SCFCL09	12	11	11,5	160	9	20	17	0	-11	0,2	CC..09T3..
	A12N-SCFCL09-R	12	-	-	160	9	20	17	0	-11	0,2	CC..09T3..
	A16Q-SCFCL09	16	15	15,5	180	11	22	22	0	-5	0,3	CC..09T3..
	A16Q-SCFCL09-R	16	-	-	180	11	22	22	0	-5	0,3	CC..09T3..
	A20R-SCFCL09	20	18	19,0	200	13	32	25	0	-5	0,4	CC..09T3..
A20R-SCFCL09-R	20	-	-	200	13	32	25	0	-5	0,4	CC..09T3..	

Spare Parts, Parts included in delivery

For size	Insert key	Insert screw	Coolant adapter
A08K...06/R	T07P-2	C02505-T07P	-
A10L...06/R	T07P-2	C02506-T07P	-
A12N...09/R	T15P-2	C04008-T15P	-
A16Q...09/R	T15P-2	C04008-T15P	SEAL16
A20R...09/R	T15P-2	C04008-T15P	SEAL20

Accessories, to be ordered separately

Please check availability in current price and stock-list

Toolholders for inserts CCGT, CCGW, CCMT and CCMW



- For insert programme, see page(s) 343-347, 400-401, 431-432
- γ_0° = Rake angle, λ_s° = Inclination angle
- For holder code key, see page(s) 16-17

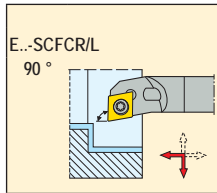
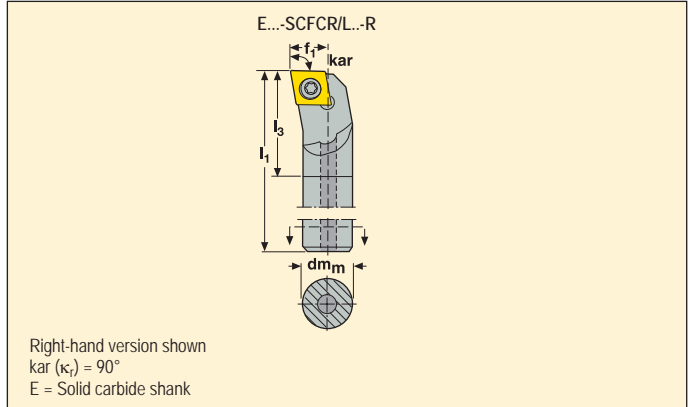

	Part No.	Dimensions in mm					γ_0°	λ_s°	KG	Key
		d_m	l_1	f_1	l_3	D_m min				
06	E08K-SCFCR06-R	8	125	5	21	10	0	-11	0,1	CC..0602..
	E10M-SCFCR06-R	10	150	7	27	13	0	-11	0,2	CC..0602..
	E08K-SCFCL06-R	8	125	5	21	10	0	-11	0,1	CC..0602..
	E10M-SCFCL06-R	10	150	7	27	13	0	-11	0,2	CC..0602..
09	E12R-SCFCR09-R	12	200	9	27	17	0	-11	0,3	CC..09T3..
	E16X-SCFCR09-R	16	230	11	34	22	0	-5	0,6	CC..09T3..
	E12R-SCFCL09-R	12	200	9	27	17	0	-11	0,3	CC..09T3..
	E16X-SCFCL09-R	16	230	11	34	22	0	-5	0,6	CC..09T3..

Spare Parts, Parts included in delivery

For size	Insert key	Insert screw
E08K-...06-R	T07P-2	C02505-T07P
E10M-...06-R	T07P-2	C02506-T07P
...09-R	T15P-2	C04008-T15P

Please check availability in current price and stock-list

Toolholders for inserts CCGT, CCGW, CCGX, CCMT and CCMW



- For insert programme, see page(s) 343-347, 400-401, 431-432
- γ_0° = Rake angle, λ_s° = Inclination angle
- For holder code key, see page(s) 16-17

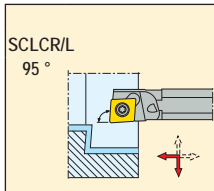
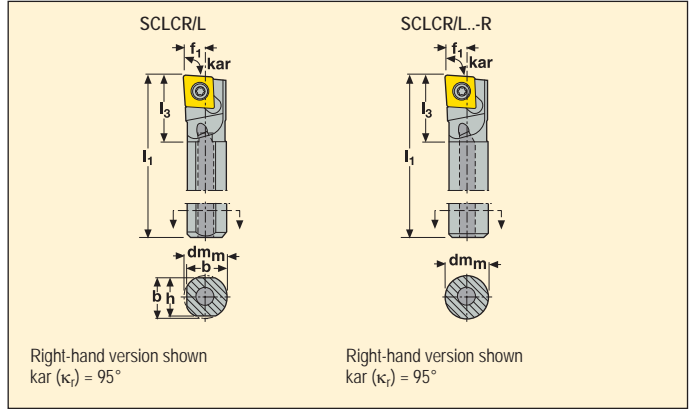

	Part No.	Dimensions in mm							D_m min	γ_0°	λ_s°	KG	
		dm_m	h	b	l_1	f_1	l_3						
06	A08K-SCLCR06	8	7	7,5	125	5	12	10	0	-11	0,1	CC..06..	
	A08K-SCLCR06-R	8	-	-	125	5	12	10	0	-11	0,1	CC..06..	
	A10L-SCLCR06	10	9	9,5	140	7	18	13	0	-11	0,1	CC..06..	
	A10L-SCLCR06-R	10	-	-	140	7	18	13	0	-11	0,1	CC..06..	
	A12N-SCLCR06	12	11	11,5	160	9	20	17	0	-11	0,1	CC..06..	
	A16Q-SCLCR06	16	15	15,5	180	11	22	22	0	-5	0,2	CC..06..	
	A08K-SCLCL06	8	7	7,5	125	5	12	10	0	-11	0,1	CC..06..	
	A08K-SCLCL06-R	8	-	-	125	5	12	10	0	-11	0,1	CC..06..	
	A10L-SCLCL06	10	9	9,5	140	7	18	13	0	-11	0,1	CC..06..	
	A10L-SCLCL06-R	10	-	-	140	7	18	13	0	-11	0,1	CC..06..	
	A12N-SCLCL06	12	11	11,5	160	9	20	17	0	-11	0,1	CC..06..	
	A16Q-SCLCL06	16	15	15,5	180	11	22	22	0	-5	0,2	CC..06..	

Spare Parts, Parts included in delivery

Accessories, to be ordered separately

For size	Insert key	Insert screw	Coolant adapter
A08K-..	T07P-2	C02505-T07P	-
A10L-..	T07P-2	C02506-T07P	-
A12N-..	T07P-2	C02506-T07P	-
A16Q-..	T07P-2	C02506-T07P	SEAL16

Please check availability in current price and stock-list

Toolholders for inserts CCGT, CCGW, CCGX, CCMT and CCMW



- For insert programme, see page(s) 343-347, 400-401, 431-432
- γ_0 = Rake angle, λ_s = Inclination angle
- For holder code key, see page(s) 16-17

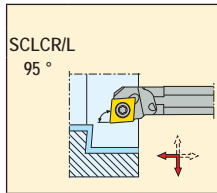
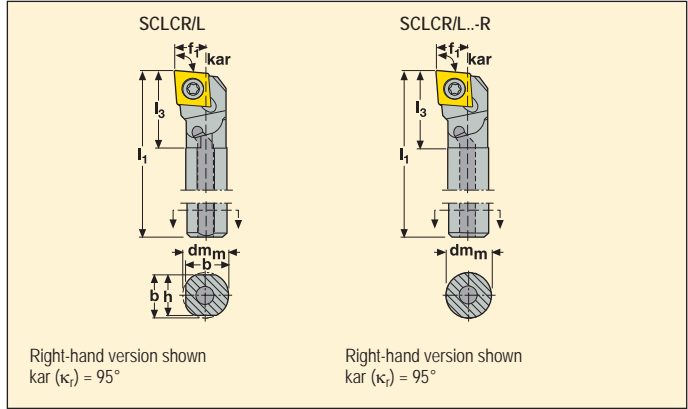

Part No.	Dimensions in mm							γ_0	λ_s	KG	Key
	$d_{m_{min}}$	h	b	l_1	f_1	l_3	$D_{m_{min}}$				
A12N-SCLCR09	12	11	11,5	160	9	20	17	0	-11	0,2	CC..09T3..
A12N-SCLCR09-R	12	-	-	160	9	20	17	0	-11	0,2	CC..09T3..
A16Q-SCLCR09	16	15	15,5	180	11	22	22	0	-5	0,2	CC..09T3..
A16Q-SCLCR09-R	16	-	-	180	11	22	22	0	-5	0,3	CC..09T3..
A20R-SCLCR09	20	18	19,0	200	13	32	25	0	-5	0,4	CC..09T3..
A20R-SCLCR09-R	20	-	-	200	13	32	25	0	-5	0,4	CC..09T3..
A12N-SCLCL09	12	11	11,5	160	9	20	17	0	-11	0,2	CC..09T3..
A12N-SCLCL09-R	12	-	-	160	9	20	17	0	-11	0,2	CC..09T3..
A16Q-SCLCL09	16	15	15,5	180	11	22	22	0	-5	0,2	CC..09T3..
A16Q-SCLCL09-R	16	-	-	180	11	22	22	0	-5	0,3	CC..09T3..
A20R-SCLCL09	20	18	19,0	200	13	32	25	0	-5	0,4	CC..09T3..
A20R-SCLCL09-R	20	-	-	200	13	32	25	0	-5	0,4	CC..09T3..

Spare Parts, Parts included in delivery

Accessories, to be ordered separately

For size	Insert key	Insert screw	Coolant adapter
A12N-..	T15P-2	C04008-T15P	-
A16Q-..	T15P-2	C04008-T15P	SEAL16
A20R-..	T15P-2	C04008-T15P	SEAL20

Please check availability in current price and stock-list

Toolholders for inserts CDCB



- For insert programme, see page(s) 348
- γ_0° = Rake angle, λ_s° = Inclination angle
- For holder code key, see page(s) 16-17

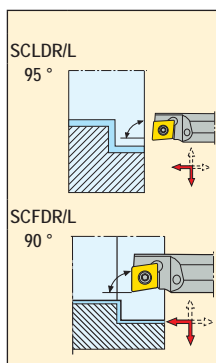
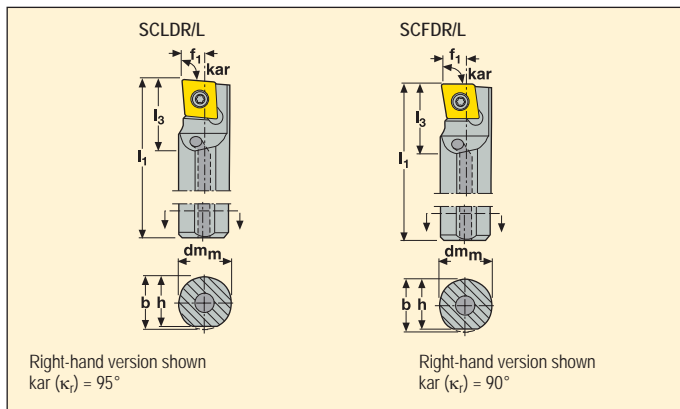

	Part No.	Dimensions in mm							γ_0°	λ_s°	KG	
		dm _m	h	b	l ₁	f ₁	l ₃	D _m min				
04	A05D-SCLDR04	5	4,70	5	60	3,0	9,7	5,5	0	-12	0,1	CD..04..
	A06E-SCLDR04	6	5,65	6	70	3,5	10,2	6,5	0	-12	0,1	CD..04..
	A08F-SCLDR04	8	7,55	8	80	4,5	11,2	8,5	0	-8	0,1	CD..04..
	A05D-SCLDL04	5	4,70	5	60	3,0	9,7	5,5	0	-12	0,1	CD..04..
	A06E-SCLDL04	6	5,65	6	70	3,5	10,2	6,5	0	-12	0,1	CD..04..
	A08F-SCLDL04	8	7,55	8	80	4,5	11,2	8,5	0	-8	0,1	CD..04..
04	A05D-SCFDR04	5	4,70	5	60	3,0	9,7	5,5	0	-12	0,1	CD..04..
	A06E-SCFDR04	6	5,65	6	70	3,5	10,2	6,5	0	-12	0,1	CD..04..
	A05D-SCFDL04	5	4,70	5	60	3,0	9,7	5,5	0	-12	0,1	CD..04..
	A06E-SCFDL04	6	5,65	6	70	3,5	10,2	6,5	0	-12	0,1	CD..04..

Spare Parts, Parts included in delivery

For size	Insert key	Insert screw
..04	T06P-2	C11804-T06P

Please check availability in current price and stock-list

Toolholders for inserts CNGA, CNGG, CNMA, CNMG, CNMM and CNMN



- For insert programme, see page(s) 348-355, 402, 431
- γ_o° = Rake angle, λ_s° = Inclination angle
- For holder code key, see page(s) 16-17

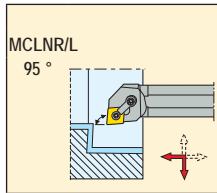
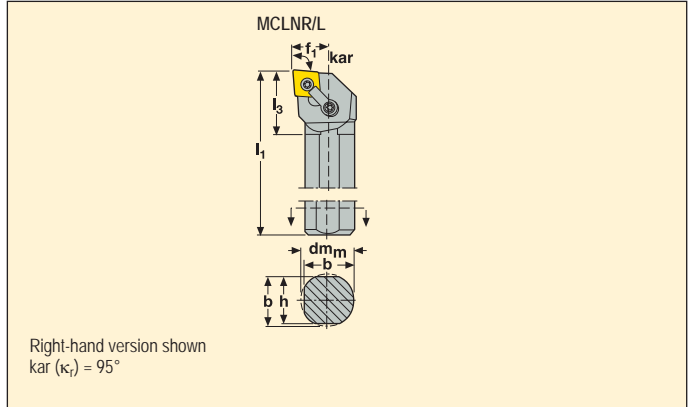

	Part No.	Dimensions in mm						γ_o°	λ_s°	KG		
		$d_{m_{min}}$	h	b	l_1	f_1	l_3					
12	S25S-MCLNR12	25	23	24,0	250	17	40	32	-5	-14	0,9	CN..1204..
	S32T-MCLNR12	32	30	31,0	300	22	50	40	-5	-14	1,8	CN..1204..
	S40U-MCLNR12	40	37	38,5	350	27	50	50	-5	-14	3,3	CN..1204..
	S25S-MCLNL12	25	23	24,0	250	17	40	32	-5	-14	0,9	CN..1204..
	S32T-MCLNL12	32	30	31,0	300	22	50	40	-5	-14	1,8	CN..1204..
	S40U-MCLNL12	40	37	38,5	350	27	50	50	-5	-14	3,3	CN..1204..
16	S50V-MCLNR16	50	47	48,5	400	35	70	63	-5	-14	5,9	CN..1606..
	S50V-MCLNL16	50	47	48,5	400	35	70	63	-5	-14	5,9	CN..1606..
19	S50V-MCLNR19	50	47	48,5	400	35	70	63	-5	-14	5,9	CN..1906..
	S50V-MCLNL19	50	47	48,5	400	35	70	63	-5	-14	5,8	CN..1906..

Spare Parts, Parts included in delivery

For size	Cantilever clamp	Clamp screw	Insert/Clamp key	Insert pin	Insert shim	Shim/clamp key	Shim pin	Plug	Shim key	Shim screw
S25S-...12	MC20	LD6020-T15P	T15P-2	MN1215S-T15P	-	-	-	P3	-	-
S32T-...12	MC20	LD6020-T15P	-	-	CSN120412	T15P-2	MN1215R-T15P	P3	-	CS6313-T15P
S40U-...12	MC20	LD6020-T15P	-	-	CSN120412	T15P-2	MN1215R-T15P	P3	-	CS6313-T15P
...16	MC12	LD8030-T25P	-	-	CSN160412	T25P-7	MN1515-T15P	P4	T15P-2	CS8016-T15P
...19	MC12	LD8030-T25P	-	-	CSN190412	T25P-7	MN1925-T25P	P4	T15P-2	-

Accessories*

Please check availability in current price and stock-list

*To be ordered separately

Toolholders for inserts CNGA, CNGG, CNMA, CNMG and CNMM



- For insert programme, see page(s) 348-355, 402, 431
- γ_0° = Rake angle, λ_s° = Inclination angle
- For holder code key, see page(s) 16-17

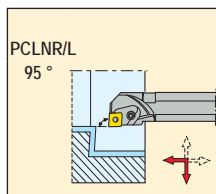
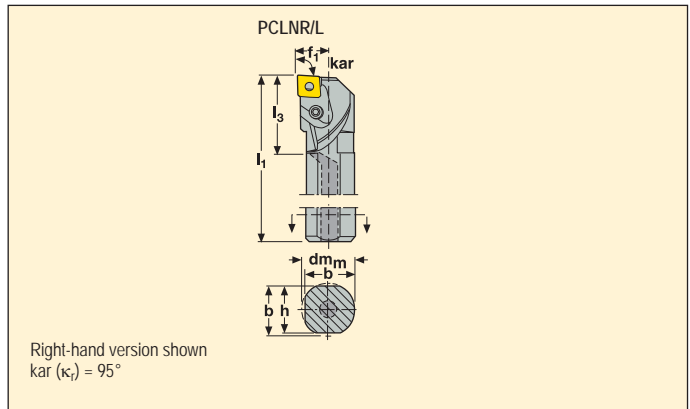

	Part No.	Dimensions in mm							γ_0°	λ_s°	KG	
		dm _m	h	b	l ₁	f ₁	l ₃	D _m min				
09	A20R-PCLNR09	20	18	19,0	200	13	30	25	-6	-12	0,4	CN..0903..
	A25S-PCLNR09	25	23	24,0	250	17	35	32	-6	-11	0,8	CN..0903..
	A20R-PCLNL09	20	18	19,0	200	13	30	25	-6	-12	0,4	CN..0903..
	A25S-PCLNL09	25	23	24,0	250	17	35	32	-6	-11	0,8	CN..0903..
12	A32T-PCLNR12	32	30	31,0	300	22	50	40	-6	-12	1,6	CN..1204..
	A40U-PCLNR12	40	37	38,5	350	27	60	50	-6	-8	2,9	CN..1204..
	A32T-PCLNL12	32	30	31,0	300	22	50	40	-6	-12	1,6	CN..1204..
	A40U-PCLNL12	40	37	38,5	350	27	60	50	-6	-8	2,9	CN..1204..

Spare Parts, Parts included in delivery

For size	Insert pin	Insert shim	Locking screw	Shim pin	Wedge clamp	Wedge key	Wedge screw
A20R...R09	110.26-653	-	-	-	110.26-639	2.5SMS795	117.26-657
A25S...R09	110.26-653	-	-	-	110.26-639	2.5SMS795	117.26-657
A20R...L09	110.26-653	-	-	-	110.26-638	2.5SMS795	117.26-657
A25S...L09	110.26-653	-	-	-	110.26-638	2.5SMS795	117.26-657
A32T...R12	-	123.26-621	136.26-651	131.26-652	110.26-641	T20P-7	WS1620-T20P
A40U...R12	-	123.26-621	136.26-651	131.26-652	110.26-641	3SMS795	117.26-655
A32T...L12	-	123.26-621	136.26-651	131.26-652	110.26-640	T20P-7	WS1620-T20P
A40U...L12	-	123.26-621	136.26-651	131.26-652	110.26-640	3SMS795	117.26-655

Accessories, to be ordered separately

Coolant adapter	Insert key	Locking key	Punch
SEAL20	2SMS795	-	-
SEAL25	2SMS795	-	-
SEAL20	2SMS795	-	-
SEAL25	2SMS795	-	-
SEAL32	-	3SMS795	117.26-687
SEAL40	-	-	117.26-687
SEAL32	-	3SMS795	117.26-687
SEAL40	-	-	117.26-687

Please check availability in current price and stock-list

Toolholders for inserts CNGA, CNGG, CNMA, CNMG and CNMM



- For insert programme, see page(s) 349-355
- γ_0° = Rake angle, λ_s° = Inclination angle
- For holder code key, see page(s) 16-17

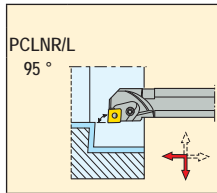
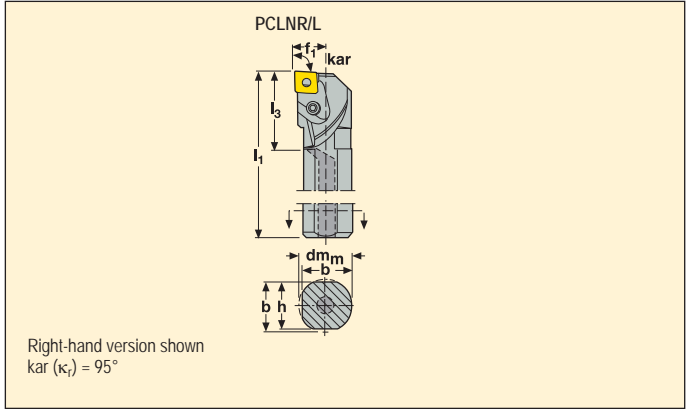

	Part No.	Dimensions in mm							γ_0°	λ_s°	KG	
		dm _m	h	b	l ₁	f ₁	l ₃	D _m min				
16	A40U-PCLNR16	40	37	38,5	350	27	60	50	-6	-12	3,0	CN..1606..
	A50V-PCLNR16	50	47	48,5	400	35	70	63	-6	-10	5,4	CN..1606..
	A40U-PCLNL16	40	37	38,5	350	27	60	50	-6	-12	3,0	CN..1606..
	A50V-PCLNL16	50	47	48,5	400	35	70	63	-6	-10	5,4	CN..1606..
19	A50V-PCLNR19	50	47	48,5	400	35	70	63	-6	-8	5,4	CN..1906..
	A50V-PCLNL19	50	47	48,5	400	35	70	63	-6	-8	5,4	CN..1906..

Spare Parts, Parts included in delivery

Accessories, to be ordered separately

For size	Insert shim	Locking screw	Shim pin	Wedge clamp	Wedge key	Wedge screw	Coolant adapter	Locking key	Punch
A40U...R16	123.26-625	136.26-651	123.26-650	110.26-643.5	T25P-7	WS2325-T25P	SEAL40	3SMS795	117.26-687
A50V...R16	123.26-625	136.26-651	123.26-650	110.26-643.5	T25P-7	WS2325-T25P	SEAL50	3SMS795	117.26-687
A40U...L16	123.26-625	136.26-651	123.26-650	110.26-642.5	T25P-7	WS2325-T25P	SEAL40	3SMS795	117.26-687
A50V...L16	123.26-625	136.26-651	123.26-650	110.26-642.5	T25P-7	WS2325-T25P	SEAL50	3SMS795	117.26-687
A50V...R19	123.26-627	131.26-651	131.26-653	110.26-643	4SMS795	170.26-655	SEAL50	-	117.26-687
A50V...L19	123.26-627	131.26-651	131.26-653	110.26-642	4SMS795	170.26-655	SEAL50	-	117.26-687

Please check availability in current price and stock-list

Toolholders for inserts CNGA, CNGG, CNMA, CNMG and CNMM



- For insert programme, see page(s) 348-355, 402, 431
- γ_0° = Rake angle, λ_s° = Inclination angle
- For holder code key, see page(s) 16-17

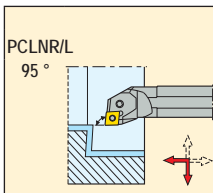
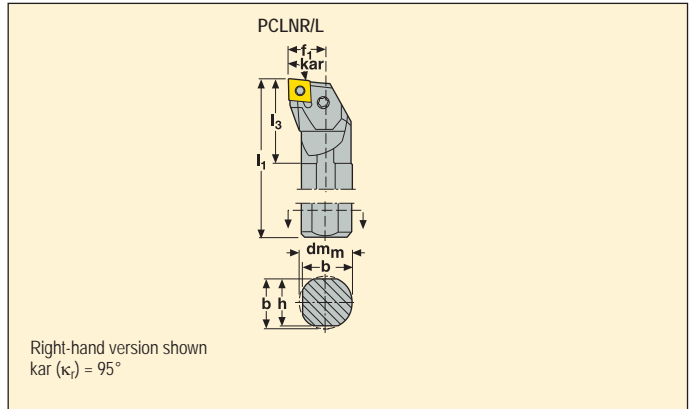

	Part No.	Dimensions in mm							γ_0°	λ_s°	KG	
		dm _m	h	b	l ₁	f ₁	l ₃	D _m min				
12	S25T-PCLNR12	25	23	23,0	300	17	40	32	-6	-10	1,1	CN..1204..
	S32U-PCLNR12	32	30	30,0	350	22	50	40	-6	-10	2,1	CN..1204..
	S40V-PCLNR12	40	37	37,5	400	27	60	50	-6	-10	3,7	CN..1204..
	S25T-PCLNL12	25	23	23,0	300	17	40	32	-6	-10	1,1	CN..1204..
	S32U-PCLNL12	32	30	30,0	350	22	50	40	-6	-10	2,1	CN..1204..
	S40V-PCLNL12	40	37	37,5	400	27	60	50	-6	-10	3,7	CN..1204..

Spare Parts, Parts included in delivery

For size	Insert lever	Insert shim	Lever key	Lever screw	Punch	Shim pin
S25T-..12	PP4613	-	2.5SMS795	LS0613	-	-
S..UV-..12	PP4713	PCN120308	3SMS795	LS0818	MP0912	RP6757

Please check availability in current price and stock-list

Toolholders for PCBN inserts CNGN and CNMN



- For insert programme, see page(s) 403
- γ_0° = Rake angle, λ_s° = Inclination angle
- For holder code key, see page(s) 16-17

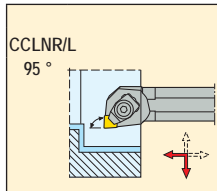
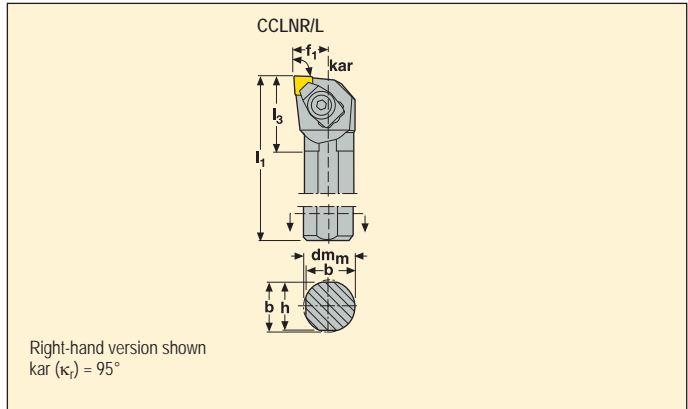

	Part No.	Dimensions in mm						γ_0°	λ_s°	KG		
		$d_{m_{min}}$	h	b	l_1	f_1	l_3					
09	S25R-CCLNR09	25	23	24,0	200	17	40	32	-6	-12	0,8	CN.N0903..
	S32S-CCLNR09	32	30	31,0	250	22	44	40	-6	-12	1,5	CN.N0903..
	S25R-CCLNL09	25	23	24,0	200	17	40	32	-6	-12	0,8	CN.N0903..
	S32S-CCLNL09	32	30	31,0	250	22	44	40	-6	-12	1,5	CN.N0903..

Spare Parts, Parts included in delivery

Accessories, to be ordered separately

For size	Cantilever clamp	Clamp key	Insert shim	Shim screw	Shim key
...09	CC14	4SMS795	CCN090316	174.10-652-T07P	T07P-2

Please check availability in current price and stock-list

Toolholders for inserts DCGT, DCMT and DCMW



- For insert programme, see page(s) 356-358, 404-405, 433
- γ_0° = Rake angle, λ_s° = Inclination angle
- For holder code key, see page(s) 16-17

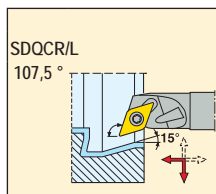
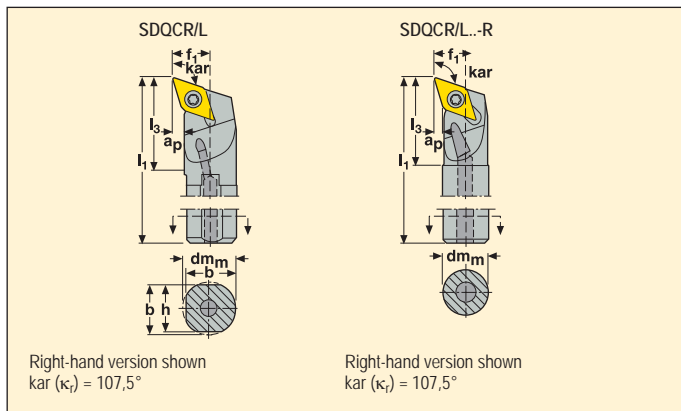

	Part No.	Dimensions in mm								γ_0°	λ_s°	KG	
		dm _m	h	b	l ₁	f ₁	l ₃	a _p	D _m min				
07	A10L-SDQCR07-R	10	-	-	140	7	18	1,5	13	0	-11	0,1	DC..0702..
	A12N-SDQCR07-R	12	-	-	160	9	20	2,5	17	0	-11	0,1	DC..0702..
	A16Q-SDQCR07	16	15	15,5	180	11	22	2,5	22	0	-5	0,3	DC..0702..
	A10L-SDQCL07-R	10	-	-	140	7	18	1,5	13	0	-11	0,1	DC..0702..
	A12N-SDQCL07-R	12	-	-	160	9	20	2,5	17	0	-11	0,1	DC..0702..
	A16Q-SDQCL07-R	16	-	-	180	11	22	2,5	22	0	-5	0,3	DC..0702..
11	A20R-SDQCR11	20	18	19,0	200	13	32	2,5	25	0	-5	0,4	DC..11T3..
	A20R-SDQCL11-R	20	-	-	200	13	32	2,5	25	0	-5	0,4	DC..11T3..
15	A25S-SDQCR15	25	23	24,0	250	17	40	4,0	32	0	-5	0,8	DC..1504..
	A25S-SDQCL15	25	23	24,0	250	17	40	4,0	32	0	-5	0,8	DC..1504..

Spare Parts, Parts included in delivery

Accessories, to be ordered separately

For size	Insert key	Insert screw	Coolant adapter
A10L-...07	T07P-2	C02506-T07P	-
A12N-...07/R	T07P-2	C02506-T07P	-
A16Q-...07/R	T07P-2	C02506-T07P	SEAL16
...11	T15P-2	C04008-T15P	SEAL20
...15	T15P-2	C04512-T15P	SEAL25

Please check availability in current price and stock-list

Toolholders for inserts DCGT, DCMT, DCMW and DCMX



- For insert programme, see page(s) 356-359, 404-405, 433
- γ_o° = Rake angle, λ_s° = Inclination angle
- For holder code key, see page(s) 16-17

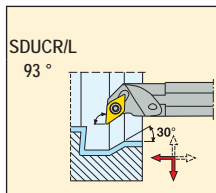
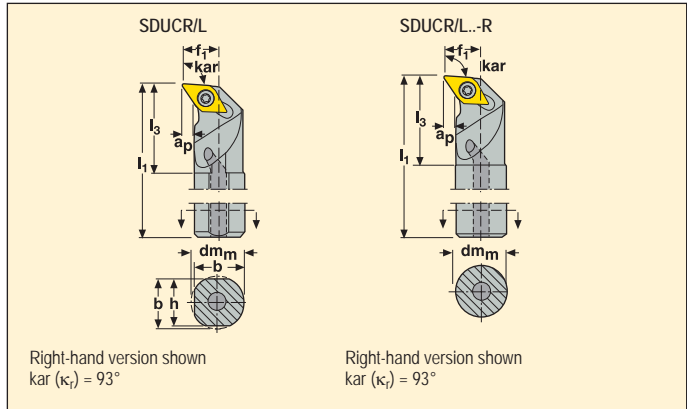

Part No.	Dimensions in mm								γ_o°	λ_s°	KG		
	dm _m	h	b	l ₁	f ₁	l ₃	a _p	D _m min					
07	A12N-SDUCR07	12	11	11,5	160	9	20	3,5	17	0	-11	0,2	DC..0702..
	A12N-SDUCR07-R	12	-	-	160	9	20	2,5	17	0	-11	0,2	DC..0702..
	A16Q-SDUCR07	16	15	15,5	180	11	22	2,5	22	0	-5	0,3	DC..0702..
	A16Q-SDUCR07-R	16	-	-	180	11	22	2,5	22	0	-5	0,3	DC..0702..
	A12N-SDUCL07	12	11	11,5	160	9	20	3,5	17	0	-11	0,2	DC..0702..
	A12N-SDUCL07-R	12	-	-	160	9	20	2,5	17	0	-11	0,2	DC..0702..
	A16Q-SDUCL07	16	15	15,5	180	11	22	2,5	22	0	-5	0,3	DC..0702..
A16Q-SDUCL07-R	16	-	-	180	11	22	2,5	22	0	-5	0,3	DC..0702..	
11	A20R-SDUCR11	20	18	19,0	200	13	30	2,5	25	0	-5	0,4	DC..11T3..
	A20R-SDUCR11-R	20	-	-	200	13	30	2,5	25	0	-5	0,4	DC..11T3..
	A25S-SDUCR11	25	23	24,0	250	17	40	4,0	32	0	-5	0,8	DC..11T3..
	A25S-SDUCR11-R	25	-	-	250	17	40	4,0	32	0	-5	0,9	DC..11T3..
	A20R-SDUCL11	20	18	19,0	200	13	30	2,5	25	0	-5	0,4	DC..11T3..
	A20R-SDUCL11-R	20	-	-	200	13	30	2,5	25	0	-5	0,4	DC..11T3..
	A25S-SDUCL11	25	23	24,0	250	17	40	4,0	32	0	-5	0,8	DC..11T3..
A25S-SDUCL11-R	25	-	-	250	17	40	4,0	32	0	-5	0,9	DC..11T3..	
15	A32T-SDUCR15	32	30	31,0	300	22	50	5,0	40	0	-5	1,6	DC..1504..
	A32T-SDUCL15	32	30	31,0	300	22	50	5,0	40	0	-5	1,6	DC..1504..

Spare Parts, Parts included in delivery

Accessories, to be ordered separately

For size	Insert key	Insert screw	Coolant adapter
A12N-...07/R	T07P-2	C02506-T07P	-
A16Q-...07/R	T07P-2	C02506-T07P	SEAL16
A20R-...11/R	T15P-2	C04008-T15P	SEAL20
A25S-...11/R	T15P-2	C04008-T15P	SEAL25
A32T-...15/R	T15P-2	C04512-T15P	SEAL32

Please check availability in current price and stock-list

Toolholders for inserts DNGA, DNGG, DNGM, DNMA, DNMG, DNMM, DNMU and DNMX



- For insert programme, see page(s) 360-365, 406-407
- γ_0° = Rake angle, λ_s° = Inclination angle
- For holder code key, see page(s) 16-17

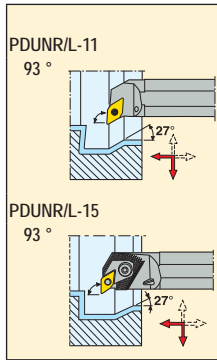
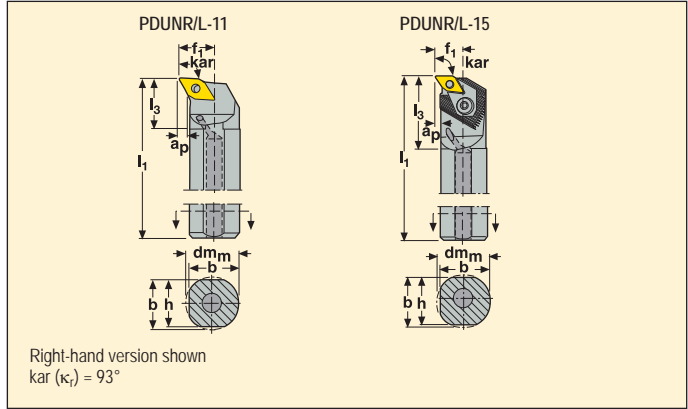

Part No.	Dimensions in mm								γ_0°	λ_s°	KG		
	dm _m	h	b	l ₁	f ₁	l ₃	a _p	D _m min					
11	A25R-PDUNR11	25	23	24,0	200	17	35	4,0	32	-5	-13	0,7	DN..1104..
	A32S-PDUNR11	32	30	31,0	250	22	37	6,0	40	-5	-11	1,4	DN..1104..
	A25R-PDUNL11	25	23	24,0	200	17	35	4,0	32	-5	-13	0,7	DN..1104..
	A32S-PDUNL11	32	30	31,0	250	22	37	6,0	40	-5	-11	1,4	DN..1104..
15	A32T-PDUNR15	32	30	31,0	300	22	50	5,0	40	-6	-15	1,6	DN..1506..
	A40U-PDUNR15	40	37	38,5	350	27	60	5,0	50	-6	-14	2,9	DN..1506..
	A50V-PDUNR15	50	47	48,5	400	35	70	5,0	63	-6	-11	5,3	DN..1506..
	A32T-PDUNL15	32	30	31,0	300	22	50	5,0	40	-6	-15	1,6	DN..1506..
	A40U-PDUNL15	40	37	38,5	350	27	60	5,0	50	-6	-14	2,9	DN..1506..
A50V-PDUNL15	50	47	48,5	400	35	70	5,0	63	-6	-11	5,3	DN..1506..	

Spare Parts, Parts included in delivery

For size	Insert key	Insert pin	Insert shim	Locking screw	Shim pin	Wedge clamp	Wedge key	Wedge screw	Coolant adapter	Locking key	Punch
A25R-11	T09P-2	PL1403-T09P	DAE110312	-	-	-	-	-	SEAL25	-	-
A32S-11	T09P-2	PL1403-T09P	DAE110312	-	-	-	-	-	SEAL32	-	-
A32T-R15	-	-	PDD150312	136.26-651	131.26-652	171.66-641	T25P-7	WS2325-T25P	SEAL32	3SMS795	117.26-687
A40U-R15	-	-	PDD150312	136.26-651	131.26-652	171.66-641	T25P-7	WS2325-T25P	SEAL40	3SMS795	117.26-687
A50V-R15	-	-	PDD150312	136.26-651	131.26-652	171.66-641	4SMS795	170.26-655	SEAL50	3SMS795	117.26-687
A32T-L15	-	-	PDD150312	136.26-651	131.26-652	171.66-640	T25P-7	WS2325-T25P	SEAL32	3SMS795	117.26-687
A40U-L15	-	-	PDD150312	136.26-651	131.26-652	171.66-640	T25P-7	WS2325-T25P	SEAL40	3SMS795	117.26-687
A50V-L15	-	-	PDD150312	136.26-651	131.26-652	171.66-640	4SMS795	170.26-655	SEAL50	3SMS795	117.26-687

Accessories*

Please check availability in current price and stock-list

*To be ordered separately
Shim PDD150412 for insert DN..1504.., to be ordered separately

Toolholders for inserts DNGA, DNGG, DNGM, DNMA, DNMG, DNMM, DNMU and DNMX



- For insert programme, see page(s) 360-365, 406-407
- γ_0° = Rake angle, λ_s° = Inclination angle
- For holder code key, see page(s) 16-17

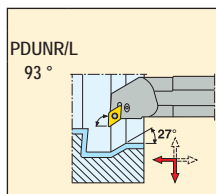
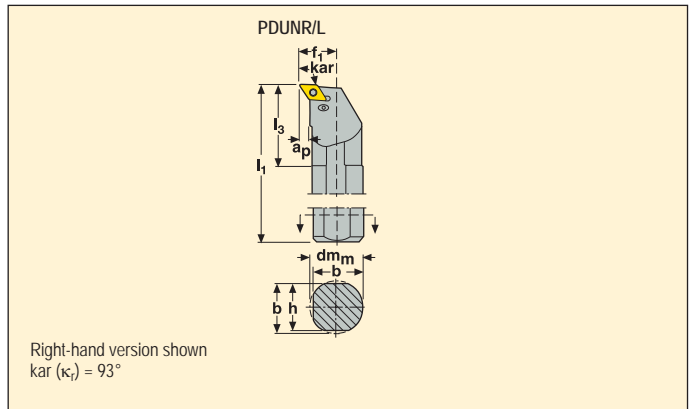

Part No.	Dimensions in mm								γ_0°	λ_s°	KG	Key	
	$d_{m\min}$	h	b	l_1	f_1	l_3	a_p	$D_{m\min}$					
11	S25T-PDUNR11	25	23	23,0	300	17	45	4,5	32	-6	-13	1,1	DN..1104..
	S32U-PDUNR11	32	30	30,0	350	22	50	6,0	40	-6	-11	2,1	DN..1104..
	S25T-PDUNL11	25	23	23,0	300	17	45	4,5	32	-6	-13	1,1	DN..1104..
	S32U-PDUNL11	32	30	30,0	350	22	50	6,0	40	-6	-11	2,1	DN..1104..
15	S32U-PDUNR15	32	30	30,0	350	22	50	6,0	40	-6	-13	2,1	DN..1506..
	S40V-PDUNR15	40	38	38,0	400	27	55	7,0	48	-6	-10	3,7	DN..1506..
	S50W-PDUNR15	50	47	48,5	450	35	70	10,0	61	-6	-10	6,4	DN..1506..
	S32U-PDUNL15	32	30	30,0	350	22	50	6,0	40	-6	-13	2,1	DN..1506..
	S40V-PDUNL15	40	38	38,0	400	27	55	7,0	48	-6	-10	3,7	DN..1506..
S50W-PDUNL15	50	47	48,5	450	35	70	10,0	61	-6	-10	6,4	DN..1506..	

Spare Parts, Parts included in delivery

For size	Insert lever	Insert shim	Lever key	Lever screw	Punch	Shim pin
S25T-...11	PP3611	–	2SMS795	LS0512	–	–
S32U-...11	PP3512	PDN110308	2.5SMS795	LS0616	MP0912	RP5153
...15	PP4716	PDN150308	3SMS795	LS0822	MP0912	RP6757

Please check availability in current price and stock-list

Toolholders for PCBN inserts DNMA



- For insert programme, see page(s) 407
- γ_o° = Rake angle, λ_s° = Inclination angle
- For holder code key, see page(s) 16-17

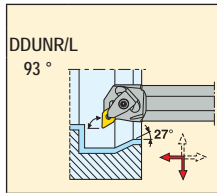
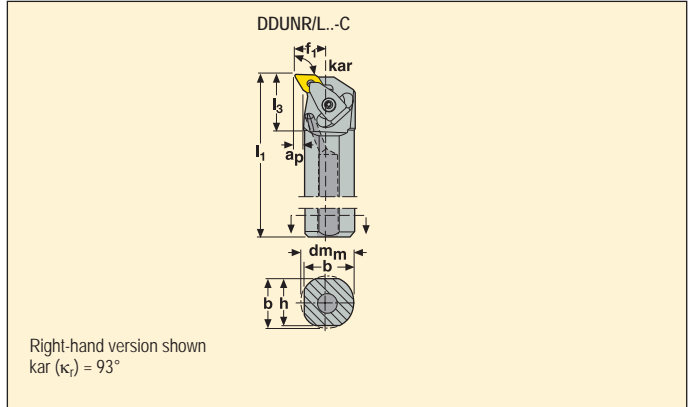

	Part No.	Dimensions in mm								γ_o°	λ_s°	KG	
		dm _m	h	b	l ₁	f ₁	l ₃	a _p	D _m min				
11	A25R-DDUNR11-C	25	23	24,0	200	17	27	4,0	32	-6	-13	0,7	DNMA1104..
	A32S-DDUNR11-C	32	30	31,0	250	22	31	6,0	40	-5	-11	1,4	DNMA1104..
	A25R-DDUNL11-C	25	23	24,0	200	17	27	4,0	32	-6	-13	0,7	DNMA1104..
	A32S-DDUNL11-C	32	30	31,0	250	22	31	6,0	40	-5	-11	1,4	DNMA1104..

Spare Parts, Parts included in delivery

Accessories*

For size	Clamp pin	Clamp screw	Floating wedge clamp	Insert shim	Shim/clamp key	Shim screw	Spring	Clamp kit
...11	FP1508	L84017-T09P	CC09P-SET	DDN110310	T09P-2	C03007-T09P	S5608	CC09P-D11

Please check availability in current price and stock-list

*To be ordered separately

Toolholders for inserts DNMA and DNMU



- For insert programme, see page(s) 364, 407
- γ_0° = Rake angle, λ_s° = Inclination angle
- For holder code key, see page(s) 16-17

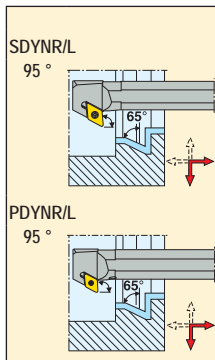
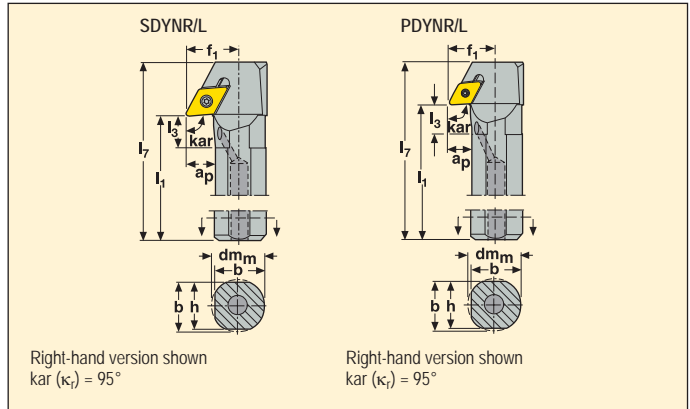

Part No.	Dimensions in mm								γ_0°	λ_s°	KG	Key	
	dm _m	h	b	l ₁	f ₁	l ₃	a _p	D _m min					
11	A20Q-SDYNR11	20	18	19	180	20,0	15	10,0	40	-5	-14	0,4	DNMU1104..
	A20Q-SDYNL11	20	18	19	180	20,0	15	10,0	40	-5	-14	0,4	DNMU1104..
11	A25R-PDYNR11	25	23	24	200	22,5	13	10,0	45	-5	-13	0,8	DN..1104..
	A32S-PDYNR11	32	30	31	250	25,5	23	9,5	51	-5	-11	1,5	DN..1104..
	A25R-PDYNL11	25	23	24	200	22,5	13	10,0	45	-5	-13	0,8	DN..1104..
	A32S-PDYNL11	32	30	31	250	25,5	23	9,5	51	51	-5	-11	1,5

Spare Parts, Parts included in delivery

For size	Insert key	Insert pin	Insert screw	Insert shim	Shim screw
A20Q...11	T09P-2	-	C03511-T09P	DAI110212	CA3507
A25R...11	T09P-2	PL1403-T09P	-	DAE110312	-
A32S...11	T09P-2	PL1403-T09P	-	DAE110312	-

Accessories*

Coolant adapter	Shim key
SEAL20	9/64SMS875
SEAL25	-
SEAL32	-

Please check availability in current price and stock-list

*To be ordered separately

Toolholders for PCBN inserts RGN and RMN



- For insert programme, see page(s) 409-411, 434, 437
- γ_0° = Rake angle, λ_s° = Inclination angle
- For holder code key, see page(s) 16-17

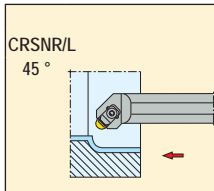
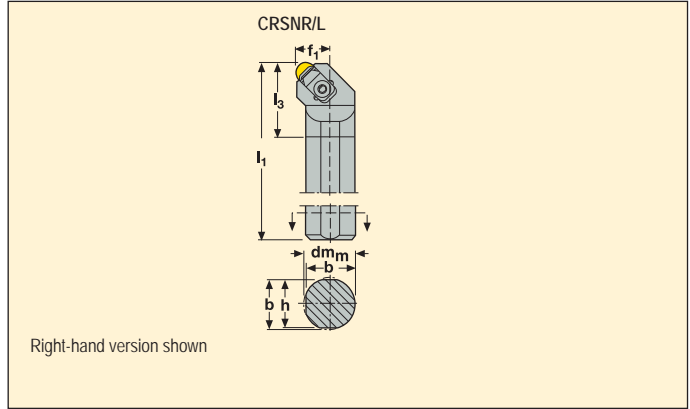

	Part No.	Dimensions in mm							γ_0°	λ_s°	KG	
		$d_{m_{min}}$	h	b	l_1	f_1	l_3	$D_{m_{min}}$				
06	S25R-CRSNR06	25	23	24,0	200	17	37	32	-6	-12	0,8	RN.N0603..
	S32S-CRSNR06	32	30	31,0	250	22	40	40	-6	-12	1,6	RN.N0603..
	S40T-CRSNR06	40	37	38,5	300	27	40	50	-6	-12	2,8	RN.N0603..
	S25R-CRSNL06	25	23	24,0	200	17	37	32	-6	-12	0,8	RN.N0603..
	S32S-CRSNL06	32	30	31,0	250	22	40	40	-6	-12	1,6	RN.N0603..
	S40T-CRSNL06	40	37	38,5	300	27	40	50	-6	-12	2,8	RN.N0603..
09	S32S-CRSNR09	32	30	31,0	250	22	40	40	-6	-12	1,5	RN.N0903..
	S40T-CRSNR09	40	37	38,5	300	27	43	50	-6	-12	2,8	RN.N0903..
	S32S-CRSNL09	32	30	31,0	250	22	40	40	-6	-12	1,6	RN.N0903..
	S40T-CRSNL09	40	37	38,5	300	27	43	50	-6	-12	2,8	RN.N0903..

Spare Parts, Parts included in delivery

For size	Cantilever clamp	Clamp key	Insert shim	Shim screw
...06	CC14	4SMS795	CRN0603M0	CS2507-T07P
...09	CC16	4SMS795	117.10-620	174.10-652-T07P

Accessories, to be ordered separately

Shim key
T07P-2
T07P-2

Please check availability in current price and stock-list

Toolholders for inserts SNGA, SNGN, SNMA, SNMG and SNMM



- For insert programme, see page(s) 374-378, 413, 416
- γ_0° = Rake angle, λ_s° = Inclination angle
- For holder code key, see page(s) 16-17

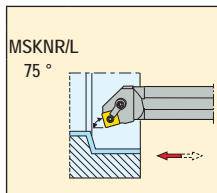
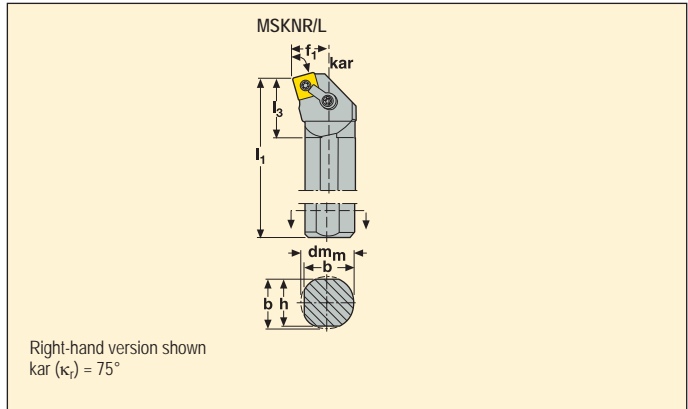

	Part No.	Dimensions in mm							γ_0°	λ_s°	KG	Key
		$d_{m_{min}}$	h	b	l_1	f_1	l_3	$D_{m_{min}}$				
12	S32T-MSKNR12	32	30	31,0	300	22	50	40	-5	-13	1,8	SN..1204..
	S40U-MSKNR12	40	37	38,5	350	27	60	50	-5	-12	3,3	SN..1204..
	S32T-MSKNL12	32	30	31,0	300	22	50	40	-5	-13	1,8	SN..1204..
	S40U-MSKNL12	40	37	38,5	350	27	60	50	-5	-12	3,3	SN..1204..
15	S50V-MSKNR15	50	47	48,5	400	35	55	63	-5	-12	5,9	SN..1506..
	S50V-MSKNL15	50	47	48,5	400	35	55	63	-5	-12	5,9	SN..1506..

Spare Parts, Parts included in delivery

Accessories*

For size	Cantilever clamp	Clamp key	Clamp screw	Insert shim	Shim/clamp key	Shim pin	Plug	Shim key	Shim screw
...12	MC20	-	LD6020-T15P	-	T15P-2	MN1215R-T15P	P3	-	CS6313-T15P
...15	MC12	T25P-7	LD8025-T25P	SSN150412	-	MN1515-T15P	P4	T15P-2	CS8016-T15P

Please check availability in current price and stock-list

*To be ordered separately

Toolholders for PCBN inserts SNGF, SNGN and SNMN



- For insert programme, see page(s) 414-415, 417
- γ_0° = Rake angle, λ_s° = Inclination angle
- For holder code key, see page(s) 16-17

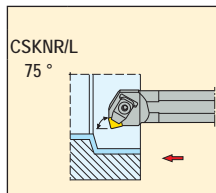
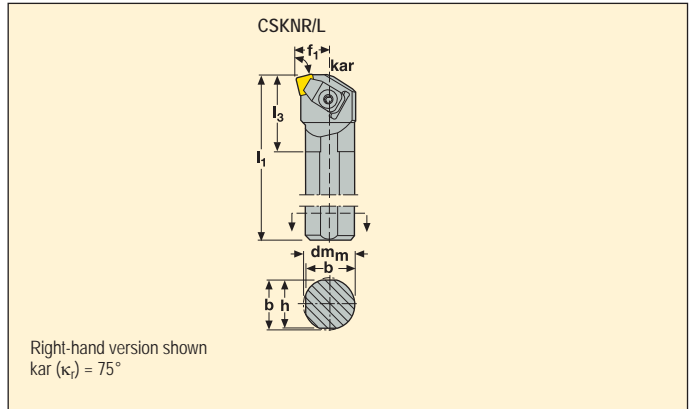

Part No.	Dimensions in mm							γ_0°	λ_s°	KG	
	d_{m_m}	h	b	l_1	f_1	l_3	$D_{m \text{ min}}$				
S25R-CSKNR09	25	23	24.0	200	17	35	32	-6	-12	0,8	SN.N0903..
S32S-CSKNR09	32	30	31,0	250	22	40	40	-6	-12	1,6	SN.N0903..
S40T-CSKNR09	40	37	38,5	300	27	40	50	-6	-12	2,8	SN.N0903..

Spare Parts, Parts included in delivery

For size	Cantilever clamp	Clamp key	Insert shim	Shim screw
S25R...09	CC14	4SMS795	174.10-620	174.10-652-T07P
S25S...09	CC16	4SMS795	174.10-620	174.10-652-T07P
S40T...09	CC16	4SMS795	174.10-620	174.10-652-T07P

Accessories, to be ordered separately

Shim key
T07P-2
T07P-2
T07P-2

Please check availability in current price and stock-list

Toolholders for inserts TCGT, TCMT and TCMW



- For insert programme, see page(s) 380-382, 419, 434
- γ_0° = Rake angle, λ_s° = Inclination angle
- For holder code key, see page(s) 16-17

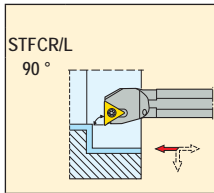
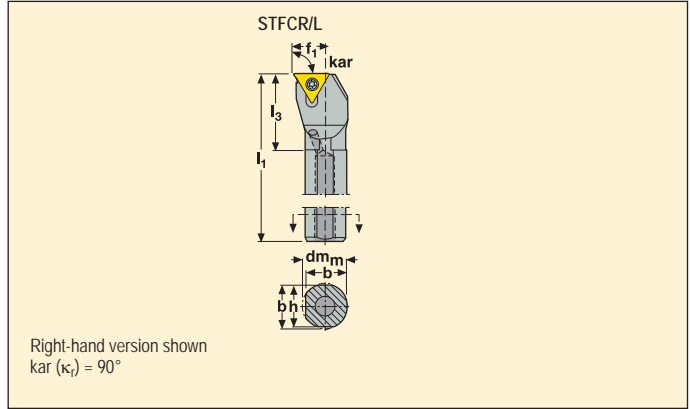

	Part No.	Dimensions in mm							γ_0°	λ_s°	KG	TC..1102..
		dm _m	h	b	l ₁	f ₁	l ₃	D _m min				
11	A12M-STFCR11	12	11	11,5	150	9	21	16	0	-10	0,2	TC..1102..
	A16R-STFCR11	16	15	15,0	200	11	25	20	0	-6	0,3	TC..1102..
	A20S-STFCR11	20	18	18,5	250	13	25	25	0	-3	0,5	TC..1102..
	A12M-STFCL11	12	11	11,5	150	9	21	16	0	-10	0,2	TC..1102..
	A16R-STFCL11	16	15	15,0	200	11	25	20	0	-6	0,3	TC..1102..
	A20S-STFCL11	20	18	18,5	250	13	25	25	0	-3	0,5	TC..1102..
16	A25R-STFCR16	25	23	24,0	200	17	36	32	0	-6	0,7	TC..16T3..
	A32S-STFCR16	32	30	31,0	250	22	42	40	0	-10	1,3	TC..16T3..
	A40T-STFCR16	40	37	38,5	300	27	50	50	0	-8	2,6	TC..16T3..
	A25R-STFCL16	25	23	24,0	200	17	36	32	0	-6	0,7	TC..16T3..
	A32S-STFCL16	32	30	31,0	250	22	42	40	0	-10	1,3	TC..16T3..
	A40T-STFCL16	40	37	38,5	300	27	50	50	0	-8	2,6	TC..16T3..

Spare Parts, Parts included in delivery

Accessories*

For size	Insert key	Insert screw	Insert shim	Shim screw	Coolant adapter	Shim key
A12M...11	T07P-2	C02506-T07P	-	-	-	-
A16R...11	T07P-2	C02506-T07P	-	-	SEAL16	-
A20S...11	T07P-2	C02506-T07P	-	-	SEAL20	-
A25R...16	T15P-2	C03509-T15P	-	-	SEAL25	-
A32S...16	T15P-2	C03509-T15P	STN160312	CA3510	SEAL32	9/64SMS875
A40T...16	T15P-2	C03509-T15P	STN160312	CA3510	SEAL40	9/64SMS875

Please check availability in current price and stock-list

*To be ordered separately

Toolholders for inserts TDAB and TDCH



- For insert programme, see page(s) 383-384
- γ_0° = Rake angle, λ_s° = Inclination angle
- For holder code key, see page(s) 16-17

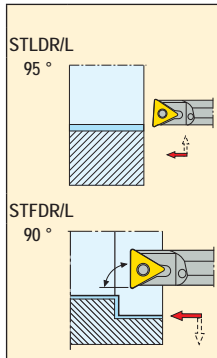
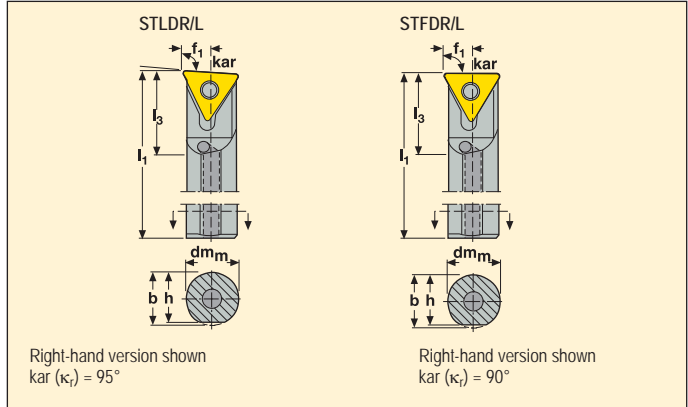

	Part No.	Dimensions in mm							γ_0°	λ_s°	KG	
		dm _m	h	b	l ₁	f ₁	l ₃	D _m min				
06	A05D-STLDR06	5	4,70	5	60	3,0	9,7	6,8	0	-12	0,1	TD..06..
	A06E-STLDR06	6	5,65	6	70	3,5	10,2	7,2	0	-12	0,1	TD..06..
	A08F-STLDR06	8	7,55	8	80	4,5	11,2	8,8	0	-8	0,1	TD..06..
	A05D-STLDR06	5	4,70	5	60	3,0	9,7	6,8	0	-12	0,1	TD..06..
	A06E-STLDR06	6	5,65	6	70	3,5	10,2	7,2	0	-12	0,1	TD..06..
	A08F-STLDR06	8	7,55	8	80	4,5	11,2	8,8	0	-8	0,1	TD..06..
06	A05D-STFDR06	5	4,70	5	60	3,0	9,7	6,8	0	-12	0,1	TD..06..
	A06E-STFDR06	6	5,65	6	70	3,5	10,2	7,2	0	-12	0,1	TD..06..
	A08F-STFDR06	8	7,55	8	80	4,5	11,2	8,8	0	-8	0,1	TD..06..
	A05D-STFDR06	5	4,70	5	60	3,0	9,7	6,8	0	-12	0,1	TD..06..
	A06E-STFDR06	6	5,65	6	70	3,5	10,2	7,2	0	-12	0,1	TD..06..
	A08F-STFDR06	8	7,55	8	80	4,5	11,2	8,8	0	-8	0,1	TD..06..

Spare Parts, Parts included in delivery

For size	Insert key	Insert screw
..06	T06P-2	C82204-T06P

Please check availability in current price and stock-list

Toolholders for inserts TNGA, TNGN, TNMA, TNMG, TNMM and TNMN



- For insert programme, see page(s) 385-389, 420
- γ_0° = Rake angle, λ_s° = Inclination angle
- For holder code key, see page(s) 16-17

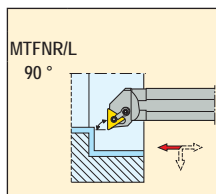
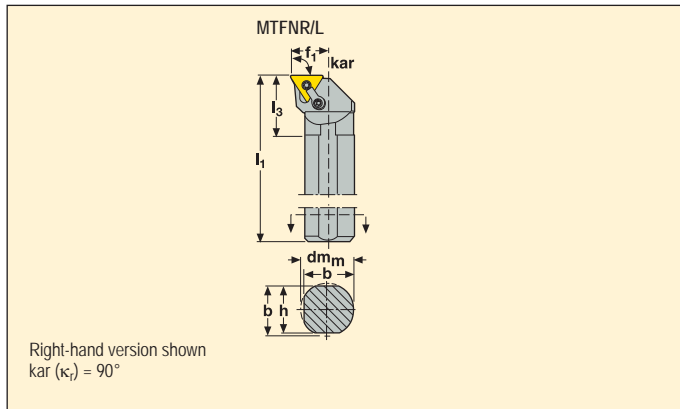

	Part No.	Dimensions in mm							γ_0°	λ_s°	KG	
		dm _m	h	b	l ₁	f ₁	l ₃	D _m min				
16	S32T-MTFNR16	32	30	31,0	300	22	50	40	-5	-14	1,9	TN..1604..
	S32T-MTFNL16	32	30	31,0	300	22	50	40	-5	-14	1,9	TN..1604..

Spare Parts, Parts included in delivery

Accessories*

For size	Cantilever clamp	Clamp screw	Insert shim	Shim/clamp key	Shim pin	Shim screw
...16						

Please check availability in current price and stock-list

*To be ordered separately
Shim TSN160412 for insert TN..1603.., to be ordered separately

Toolholders for PCBN inserts TNGN, TNGX, TNMN and TNMX



- For insert programme, see page(s) 421-425
- γ_o° = Rake angle, λ_s° = Inclination angle
- For holder code key, see page(s) 16-17

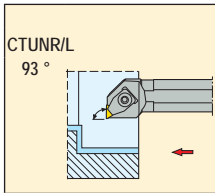
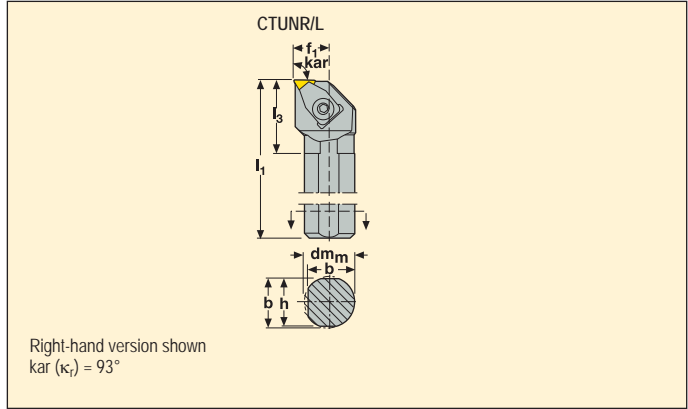

	Part No.	Dimensions in mm							γ_o°	λ_s°	KG	
		$d_{m_{min}}$	h	b	l_1	f_1	l_3	$D_{m_{min}}$				
11	S25R-CTUNR11	25	23	24,0	200	17	40	32	-6	-10	0,8	TN.N/TN.X1103..
	S32S-CTUNR11	32	30	31,0	250	22	40	40	-6	-10	1,5	TN.N/TN.X1103..
	S25R-CTUNL11	25	23	24,0	200	17	40	32	-6	-10	0,8	TN.N/TN.X1103..
	S32S-CTUNL11	32	30	31,0	250	22	40	40	-6	-10	1,5	TN.N/TN.X1103..

Spare Parts, Parts included in delivery

Accessories, to be ordered separately

For size	Cantilever clamp	Clamp key	Insert shim	Shim screw	Shim key
...11	 CC14	 4SMS795	 CTN110308	 CS2507-T07P	 T07P-2

Please check availability in current price and stock-list

Shim CTN110312 for insert TN.N110312 and TNMX110308S-WZ, to be ordered separately

Toolholders for inserts VBGT, VBGW, VBMT, VBMM and VCGT



- For insert programme, see page(s) 391-392, 426, 435
- γ_0° = Rake angle, λ_s° = Inclination angle
- For holder code key, see page(s) 16-17

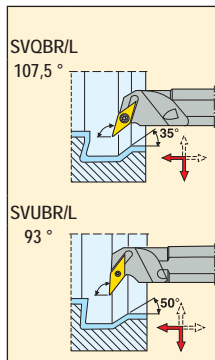
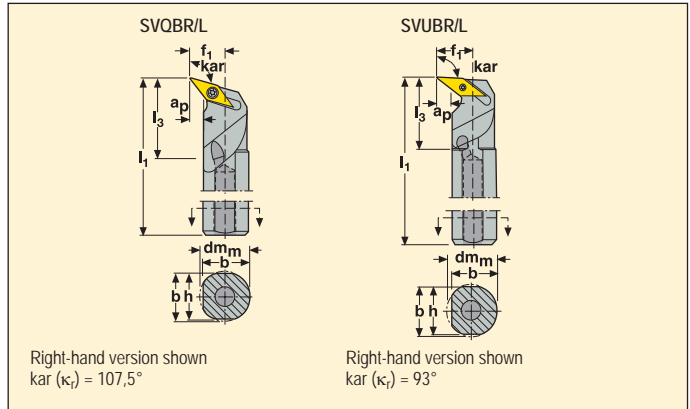

	Part No.	Dimensions in mm							D _m min	γ_0°	λ_s°	KG	
		dm _m	h	b	l ₁	f ₁	l ₃	a _p					
11	A16R-SVQBR11	16	15	15,0	200	13	25	4,5	22	0	-7	0,3	VB..1102..
	A20S-SVQBR11	20	18	18,5	250	15	25	4,5	27	0	-6	0,5	VB..1102..
	A25T-SVQBR11	25	23	22,5	300	18	35	5,0	33	0	-4	1,0	VB..1102..
	A16R-SVQBL11	16	15	15,0	200	13	25	4,5	22	0	-7	0,3	VB..1102..
	A20S-SVQBL11	20	18	18,5	250	15	25	4,5	27	0	-6	0,5	VB..1102..
	A25T-SVQBL11	25	23	22,5	300	18	35	5,0	33	0	-4	1,0	VB..1102..
16	A25S-SVQBR16	25	23	24,0	250	17	65	4,0	32	0	-8	0,8	VB../VC..1604..
	A32T-SVQBR16	32	30	31,0	300	22	70	5,5	40	0	-8	1,6	VB../VC..1604..
	A40U-SVQBR16	40	37	38,5	350	27	80	6,5	50	0	-8	2,9	VB../VC..1604..
	A25S-SVQBL16	25	23	24,0	250	17	65	4,0	32	0	-8	0,8	VB../VC..1604..
	A32T-SVQBL16	32	30	31,0	300	22	70	5,5	40	0	-8	1,5	VB../VC..1604..
	A40U-SVQBL16	40	37	38,5	350	27	80	6,5	50	0	-8	2,9	VB../VC..1604..
11	A16R-SVUBR11	16	15	15,0	200	13	25	4,5	22	0	-7	0,3	VB..1102..
	A20S-SVUBR11	20	18	18,5	250	15	25	4,5	27	0	-5	0,5	VB..1102..
	A25T-SVUBR11	25	23	22,5	300	18	35	5,0	33	0	-3	1,0	VB..1102..
	A16R-SVUBL11	16	15	15,0	200	13	25	4,5	22	0	-7	0,3	VB..1102..
	A20S-SVUBL11	20	18	18,5	250	15	25	4,5	27	0	-5	0,5	VB..1102..
	A25T-SVUBL11	25	23	22,5	300	18	35	5,0	33	0	-3	1,0	VB..1102..

Spare Parts, Parts included in delivery

For size	Insert key	Insert screw	Insert shim	Shim screw
A16R-...11	T07P-2	C02506-T07P	-	-
A20S-...11	T07P-2	C02506-T07P	-	-
A25T-...11	T07P-2	C02506-T07P	-	-
A25S-...16	T15P-2	C03510-T15P	171.19-620	CA3507
A32T-...16	T15P-2	C03510-T15P	171.19-620	CA3507
A40U-...16	T15P-2	C03510-T15P	171.19-620	CA3507

Accessories*

Coolant adapter	Shim key
SEAL16	-
SEAL20	-
SEAL25	-
SEAL25	9/64SMS875
SEAL32	9/64SMS875
SEAL40	9/64SMS875

Please check availability in current price and stock-list

*To be ordered separately

Toolholders for inserts VNGA, VNGG, VNGM, VNMA and VNMG



- For insert programme, see page(s) 393-394, 426
- γ_0° = Rake angle, λ_s° = Inclination angle
- For holder code key, see page(s) 16-17

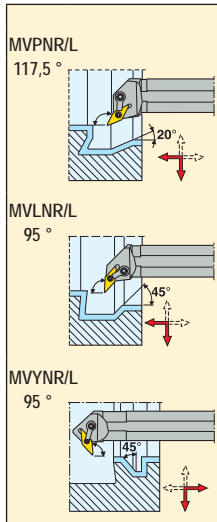
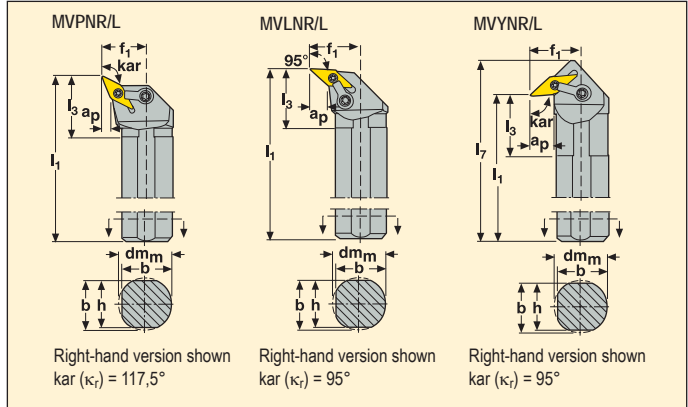

	Part No.	Dimensions in mm											D _m min	γ_0°	λ_s°	KG	
		dm _m	h	b	l ₁	f ₁	l ₇	l ₃	a _p								
16	S32T-MVPNR16	32	30	31	300	27	-	50	10	46	-5	-12	1,8	VN..1604..			
	S32T-MVPLN16	32	30	31	300	27	-	50	10	46	-5	-12	1,8	VN..1604..			
16	S32T-MVLNR16	32	30	31	300	30	-	50	13	48	-5	-12	1,8	VN..1604..			
	S32T-MVLNL16	32	30	31	300	30	-	50	13	48	-5	-12	1,8	VN..1604..			
16	S32T-MVYNR16	32	30	31	300	30	320	50	13	48	-5	-12	2,0	VN..1604..			
	S32T-MVYNL16	32	30	31	300	30	320	50	13	48	-5	-12	2,0	VN..1604..			

Spare Parts, Parts included in delivery

For size	Cantilever clamp	Clamp screw	Insert shim	Shim/clamp key	Shim pin
...16	MC20	LD6021-T09P	VSN160316	T09P-2	MN0909L-T09P

Please check availability in current price and stock-list

Toolholders for inserts VNMU



- For insert programme, see page(s) 394
- γ_0° = Rake angle, λ_s° = Inclination angle
- For holder code key, see page(s) 16-17

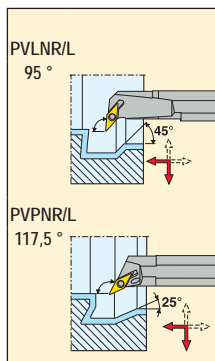
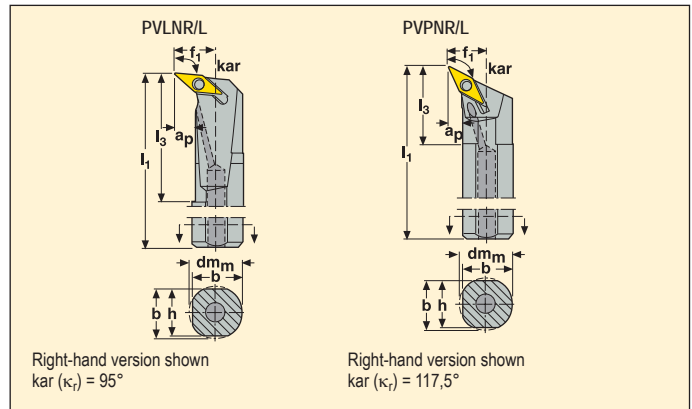

Part No.	Dimensions in mm								D_m min	γ_0°	λ_s°	KG	Key
	d_{m_m}	h	b	l_1	f_1	l_3	a_p						
13	A25R-PVLNR13	25	23	24	200	18	57	9,5	32	-5	-14	0,6	VNMU1304..
	A32S-PVLNR13	32	30	31	250	23	50	6,5	40	-5	-14	1,3	VNMU1304..
	A25R-PVLNL13	25	23	24	200	18	57	9,5	32	-5	-14	0,6	VNMU1304..
	A32S-PVLNL13	32	30	31	250	23	50	6,5	40	-5	-14	1,3	VNMU1304..
13	A25R-PVPNR13	25	23	24	200	17	34	4,0	32	-5	-19	0,7	VNMU1304..
	A32S-PVPNR13	32	30	31	250	22	35	5,5	40	-5	-16	1,3	VNMU1304..
	A25R-PVPNL13	25	23	24	200	17	34	4,0	32	-5	-19	0,7	VNMU1304..
	A32S-PVPNL13	32	30	31	250	22	35	5,5	40	-5	-16	1,3	VNMU1304..

Spare Parts, Parts included in delivery

For size	Insert key	Insert pin	Insert shim
A25R...13	T09P-2	PL1403-T09P	PVN130308
A32S...13	T09P-2	PL1403-T09P	PVN130308

Accessories, to be ordered separately

Coolant adapter
SEAL25
SEAL32

Please check availability in current price and stock-list

Toolholders for inserts WCMT



- For insert programme, see page(s) 395
- γ_o° = Rake angle, λ_s° = Inclination angle
- For holder code key, see page(s) 16-17

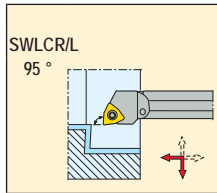
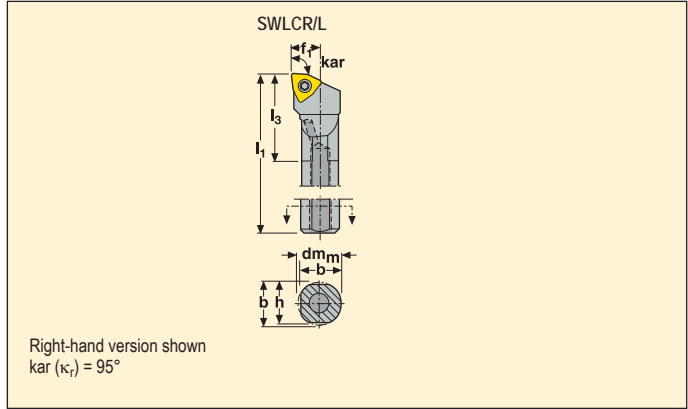

	Part No.	Dimensions in mm							γ_o°	λ_s°	KG	
		dm _m	h	b	l ₁	f ₁	l ₃	D _m min				
06	A16M-SWLCR06	16	15	15,5	150	11	21	20	0	-5	0,2	WCMT06T3..
	A20Q-SWLCR06	20	18	19,0	180	13	37	25	0	-5	0,4	WCMT06T3..
	A16M-SWLCCL06	16	15	15,5	150	11	21	20	0	-5	0,2	WCMT06T3..
	A20Q-SWLCCL06	20	18	19,0	180	13	37	25	0	-5	0,4	WCMT06T3..

Spare Parts, Parts included in delivery

Accessories, to be ordered separately

For size	Insert key	Insert screw	Coolant adapter
A16M-...06	T15P-2	C03508-T15P	SEAL16
A20Q-...06	T15P-2	C03508-T15P	SEAL20

Please check availability in current price and stock-list

Toolholders for inserts WNGA, WNMA, WNMG and WNNM



- For insert programme, see page(s) 396-399, 429
- γ_o° = Rake angle, λ_s° = Inclination angle
- For holder code key, see page(s) 16-17

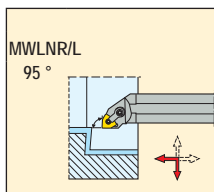
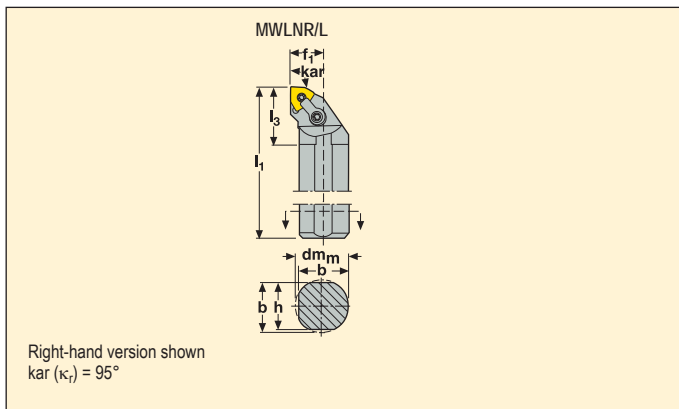

	Part No.	Dimensions in mm							γ_o°	λ_s°	KG	
		$d_{m_{min}}$	h	b	l_1	f_1	l_3	$D_{m_{min}}$				
08	S25S-MWLNLR08	25	23	24,0	250	17	40	32	-5	-11	0,9	WN..0804..
	S32T-MWLNLR08	32	30	31,0	300	22	50	40	-5	-14	1,8	WN..0804..
	S40U-MWLNLR08	40	37	38,5	350	27	50	50	-5	-12	3,2	WN..0804..
	S25S-MWLNLR08	25	23	24,0	250	17	40	32	-5	-11	0,9	WN..0804..
	S32T-MWLNLR08	32	30	31,0	300	22	50	40	-5	-14	1,8	WN..0804..
	S40U-MWLNLR08	40	37	38,5	350	27	50	50	-5	-12	3,2	WN..0804..

Spare Parts, Parts included in delivery

For size	Cantilever clamp	Clamp screw	Insert/Clamp key	Insert pin	Insert shim	Shim/clamp key	Shim pin	Plug
S25S-...08	MC20	LD6020-T15P	T15P-2	MN1215S-T15P	–	–	–	P3
S32T-...08	MC21	LD6025-T15P	–	–	MWN080412	T15P-2	MN1215T-T15P	P3
S40U-...08	MC21	LD6025-T15P	–	–	MWN080412	T15P-2	MN1215T-T15P	P3

Accessories*

Please check availability in current price and stock-list

*To be ordered separately

Toolholders for inserts WNGA, WNGG, WNMA, WNMG and WNMM



- For insert programme, see page(s) 396-399, 429
- γ_0° = Rake angle, λ_s° = Inclination angle
- For holder code key, see page(s) 16-17

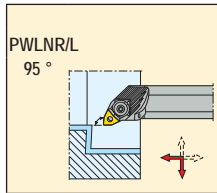
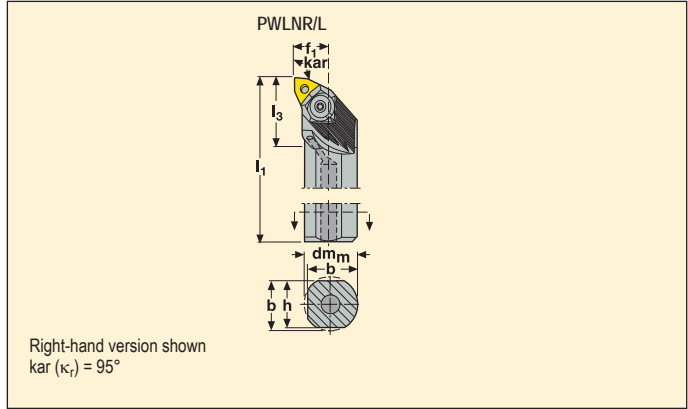

Part No.	Dimensions in mm							γ_0°	λ_s°	KG	Symbol	
	dm _m	h	b	l ₁	f ₁	l ₃	D _m min					
06	A20Q-PWLNRO6	20	18	19,0	180	13	27	25	-5	-14	0,4	WN..0604..
	A25R-PWLNRO6	25	23	24,0	200	17	30	32	-5	-12	0,6	WN..0604..
	A32S-PWLNRO6	32	30	31,0	250	22	31	40	-5	-12	1,3	WN..0604..
	A40T-PWLNRO6	40	37	38,5	300	27	40	50	-5	-12	2,5	WN..0604..
	A20Q-PWLNLO6	20	18	19,0	180	13	27	25	-5	-14	0,4	WN..0604..
	A25R-PWLNLO6	25	23	24,0	200	17	30	32	-5	-12	0,7	WN..0604..
	A32S-PWLNLO6	32	30	31,0	250	22	31	40	-5	-12	1,3	WN..0604..
A40T-PWLNLO6	40	37	38,5	300	27	40	50	-5	-12	2,5	WN..0604..	
08	A25R-PWLNRO8	25	23	24,0	200	17	30	32	-5	-11	0,7	WN..0804..
	A32S-PWLNRO8	32	30	31,0	250	22	31	40	-5	-11	1,3	WN..0804..
	A40T-PWLNRO8	40	37	38,5	300	27	35	50	-5	-14	2,5	WN..0804..
	A25R-PWLNLO8	25	23	24,0	200	17	30	32	-5	-11	0,7	WN..0804..
	A32S-PWLNLO8	32	30	31,0	250	22	31	40	-5	-11	1,3	WN..0804..
	A40T-PWLNLO8	40	37	38,5	300	27	35	50	-5	-14	2,5	WN..0804..

Spare Parts, Parts included in delivery

For size	Insert shim	Setting screw	Shim pin	Wedge clamp	Wedge key	Wedge screw	Coolant adapter	Shim key
A20Q-...06	WAI060212	L82511-T07P	PP1209-T09P	WNW06HD	T20P-7	WS1620-T20P	SEAL20	T09P-2
A25R-...06	WAI060212	L82511-T07P	PP1209-T09P	WNW06HD	T20P-7	WS1920-T20P	SEAL25	T09P-2
A32S-...06	WAE060312	L82511-T07P	PP1409-T09P	WNW06HD	T20P-7	WS1920-T20P	SEAL32	T09P-2
A40T-...06	WAE060312	L82511-T07P	PP1409-T09P	WNW06HD	T20P-7	WS1920-T20P	SEAL40	T09P-2
A25R-...08	WAI080312	L82511-T07P	PP1415-T15P	WNW08HD	T25P-7	WS2325-T25P	SEAL25	T15P-2
A32S-...08	WAI080312	L82511-T07P	PP1415-T15P	WNW08HD	T25P-7	WS2325-T25P	SEAL32	T15P-2
A40T-...08	WAI080312	L82511-T07P	PP1415-T15P	WNW08HD	T25P-7	WS2325-T25P	SEAL40	T15P-2

Accessories*

Please check availability in current price and stock-list

*To be ordered separately

Toolholders for PCBN inserts WNGA and WNMA



- For insert programme, see page(s) 429-430
- γ_0° = Rake angle, λ_s° = Inclination angle
- For holder code key, see page(s) 16-17

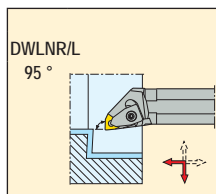
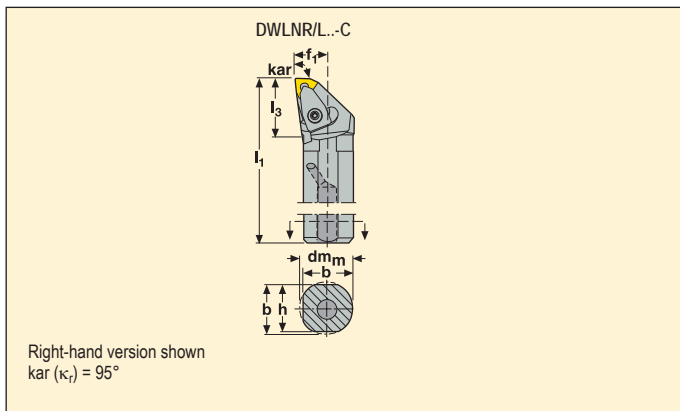

	Part No.	Dimensions in mm							γ_0°	λ_s°	KG	Insert
		dm _m	h	b	l ₁	f ₁	l ₃	D _m min				
06	A25R-DWLNRO6-C	25	23	24,0	200	17	33	32	-5	-12	0,7	WN.A0604..
	A32S-DWLNRO6-C	32	30	31,0	250	22	38	40	-5	-12	1,3	WN.A0604..
	A25R-DWLNLO6-C	25	23	24,0	200	17	33	32	-5	-12	0,7	WN.A0604..
	A32S-DWLNLO6-C	32	30	31,0	250	22	38	40	-5	-12	1,3	WN.A0604..
08	A25R-DWLNRO8-C	25	23	24,0	200	17	28	32	-5	-11	0,7	WN.A0804..
	A32S-DWLNRO8-C	32	30	31,0	250	22	40	40	-5	-11	1,4	WN.A0804..
	A25R-DWLNLO8-C	25	23	24,0	200	17	28	32	-5	-11	0,7	WN.A0804..
	A32S-DWLNLO8-C	32	30	31,0	250	22	40	40	-5	-11	1,4	WN.A0804..

Spare Parts, Parts included in delivery

Accessories*

For size	Clamp pin	Clamp screw	Floating wedge clamp	Insert shim	Shim/clamp key	Shim screw	Spring	Clamp kit
...06	FP1508	L84017-T09P	CC09P-SET	DWD060210	T09P-2	C03007-T09P	S6608	CC09P-D11
...08	FP2012	L85021-T15P	CC12P-SET	DWD080316	T15P-2	C04008-T15P	S6912	CC12P-S12

Please check availability in current price and stock-list

*To be ordered separately

Steadyline® damping holders with GL connection

Seco-Capto™/ISO 26623-1

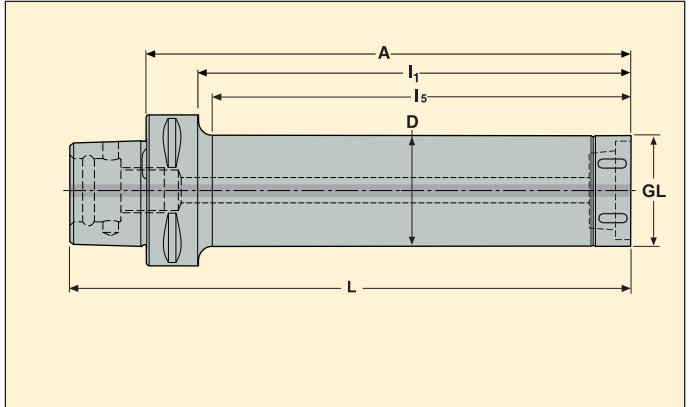

- With dynamic damping, ready to use
- With through coolant
- For GL heads programme, see page(s) 306-313

Machine side	Workpiece side	Part No.	Dimensions in mm					Max rpm*	Balancing	
			A	D	L	I ₁	I ₅			
Seco-Capto™ shank size	GL bore size									
C4	GL32	C4-D32-160-GL32	160	32	189,3	140	137	4000	2	1,20
	GL32	C4-D32-224-GL32	224	32	253,3	204	201	4000	2	1,70
	GL32	C4-D32-288-GL32	288	32	317,5	268	265	4000	2	2,10
C5	GL32	C5-D32-160-GL32	160	32	195,5	140	136	4000	2	1,40
	GL32	C5-D32-224-GL32	224	32	259,5	204	200	4000	2	1,80
	GL32	C5-D32-288-GL32	288	32	323,5	268	264	4000	2	2,20
	GL40	C5-D40-208-GL40	208	40	244,5	188	184	3500	2	2,50
	GL40	C5-D40-288-GL40	288	40	324,3	268	264	3500	2	3,30
	GL40	C5-D40-368-GL40	368	40	404,5	348	344	3500	2	4,30
C6	GL32	C6-D32-160-GL32	160	32	203,5	135	129	4000	2	1,80
	GL32	C6-D32-224-GL32	224	32	267,3	199	193	4000	2	2,20
	GL32	C6-D32-288-GL32	288	32	331,5	263	257	4000	2	2,60
	GL40	C6-D40-208-GL40	208	40	252,5	183	177	3500	2	2,90
	GL40	C6-D40-288-GL40	288	40	332,3	263	257	3500	2	3,70
	GL40	C6-D40-368-GL40	368	40	412,5	343	337	3500	2	4,60
	GL50	C6-D50-268-GL50	268	50	313,5	243	238	2500	2	5,00
	GL50	C6-D50-368-GL50	368	50	413,5	343	338	2500	2	6,60
	GL50	C6-D50-468-GL50	468	50	513,5	443	438	2500	2	8,50

* Max. RPM only when used in rotating boring

Accessories*

Spare Parts, Parts included in delivery

For nut of GL bore size	Replaceable end	Torque key	For nut of GL bore size	Locking key
GL32	SL00-32	SL00-32.250	GL32	SL32
GL40	SL00-40	SL00-40.350	GL40	SL40
GL50	SL00-50	SL00-50.550	GL50	SL50

Please check availability in current price and stock-list

*To be ordered separately

Steadylite® damping holders with GL connection

Cylindrical shank



- With dynamic damping, ready to use
- With through coolant
- For GL heads programme, see page(s) 306-313

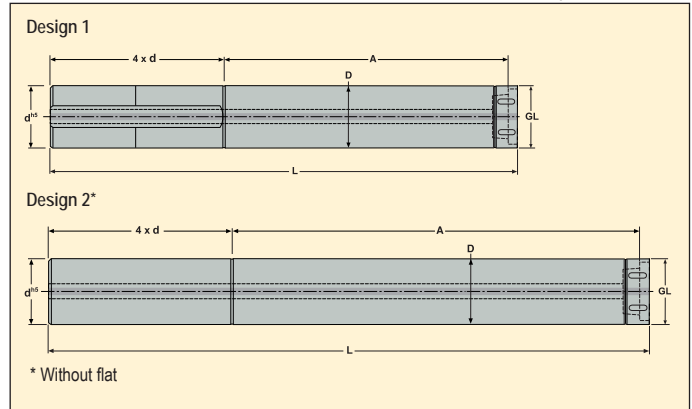

Machine side	Workpiece side	Part No.	Dimensions in mm			Design	
			A	D	L		
32	GL32	D32-160-GL32	160	32	293,3	1	1,80
	GL32	D32-224-GL32	224	32	357,5	1	2,30
	GL32	D32-288-GL32	288	32	421,5	2	2,70
40	GL40	D40-208-GL40	208	40	374,5	1	3,80
	GL40	D40-288-GL40	288	40	454,5	1	4,60
	GL40	D40-368-GL40	368	40	534,5	2	5,50
50	GL50	D50-268-GL50	268	50	475,5	1	7,50
	GL50	D50-368-GL50	368	50	575,5	1	9,10
	GL50	D50-468-GL50	468	50	675,5	2	11,00

Accessories*

Spare Parts, Parts included in delivery

For nut of GL bore size	Replaceable end	Torque key	For nut of GL bore size	Locking key
GL32	SL00-32	SL00-32.250	GL32	SL32
GL40	SL00-40	SL00-40.350	GL40	SL40
GL50	SL00-50	SL00-50.550	GL50	SL50

Please check availability in current price and stock-list

*To be ordered separately

Toolholders for inserts CCGT, CCGX and CCMT

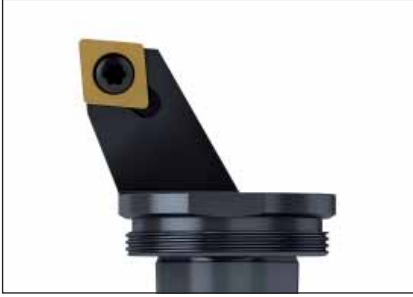

- For insert programme, see page(s) 343-347, 400-401, 431
- γ_o° = Rake angle, λ_s° = Inclination angle
- For holder code key, see page(s) 12-13
- For damping holders programme, see page(s) 304-305

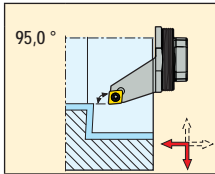
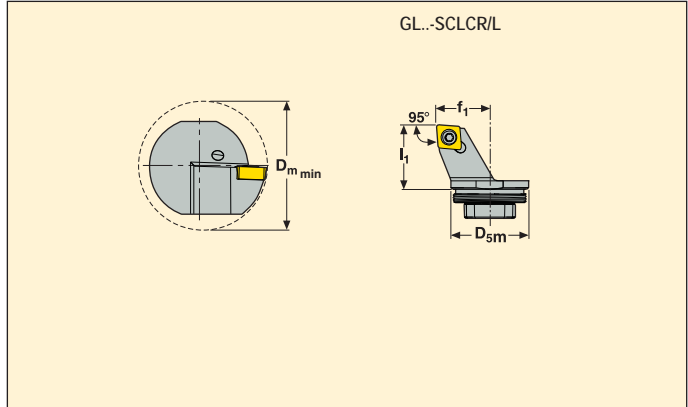

Size		Part No.	Dimensions in mm			γ_o°	λ_s°		
			D_m min	f_1	l_1				
GL32	06	GL32-SCLCR-22032-06	40	22,0	32	0	-2	0,1	CC..0602
		GL32-SCLCL-22032-06	40	22,0	32	0	-2	0,1	CC..0602
	09	GL32-SCLCR-22032-09	40	22,0	32	0	-2	0,1	CC..09T3
		GL32-SCLCL-22032-09	40	22,0	32	0	-2	0,1	CC..09T3
	12	GL32-SCLCR-22032-12	40	22,0	32	0	-8	0,1	CC..1204..
		GL32-SCLCL-22032-12	40	22,0	32	0	-8	0,1	CC..1204..
GL40	06	GL40-SCLCR-27032-06	50	27,0	32	0	-2	0,2	CC..0602
		GL40-SCLCL-27032-06	50	27,0	32	0	-2	0,2	CC..0602
	09	GL40-SCLCR-27032-09	50	27,0	32	0	-2	0,2	CC..09T3
		GL40-SCLCL-27032-09	50	27,0	32	0	-2	0,2	CC..09T3
	12	GL40-SCLCR-27032-12	50	27,0	32	0	-8	0,2	CC..1204..
		GL40-SCLCL-27032-12	50	27,0	32	0	-8	0,2	CC..1204..
GL50	06	GL50-SCLCR-32032-06	63	32,0	32	0	-2	0,3	CC..0602
		GL50-SCLCL-32032-06	63	32,0	32	0	-2	0,3	CC..0602
	09	GL50-SCLCR-32032-09	63	32,0	32	0	-2	0,3	CC..09T3
		GL50-SCLCL-32032-09	63	32,0	32	0	-2	0,3	CC..09T3
	12	GL50-SCLCR-32032-12	63	32,0	32	0	-5	0,3	CC..1204..
		GL50-SCLCL-32032-12	63	32,0	32	0	-5	0,3	CC..1204..

Spare Parts, Parts included in delivery

For size	Insert key	Insert screw	Insert shim	Shim screw
..06	T07P-2	C02506-T07P	-	-
..09	T15P-2	C04008-T15P	-	-
..12	T15P-2	C05012-T15P	123.19-621	CA5008

Accessories*

Shim key
-
-
5SMS795

Please check availability in current price and stock-list

*To be ordered separately

Toolholders for inserts TCGT, TCGX, TCMT, TCMW and TCMX



- For insert programme, see page(s) 380-383, 434
- γ_o° = Rake angle, λ_s° = Inclination angle
- For holder code key, see page(s) 12-13
- For damping holders programme, see page(s) 304-305

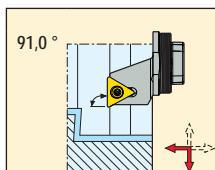
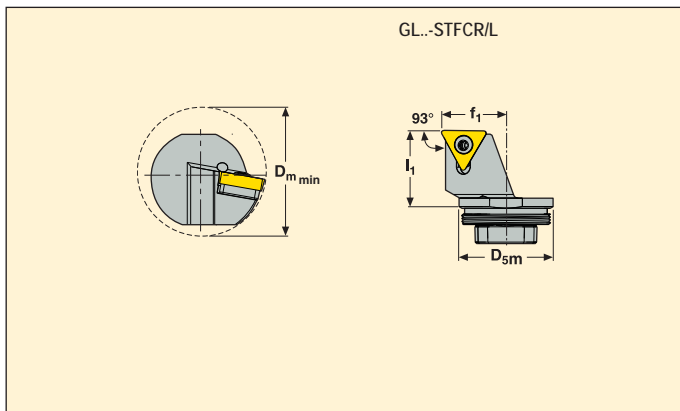

Size		Part No.	Dimensions in mm			γ_o°	λ_s°		
			D_m min	f_1	l_1				
GL32	16	GL32-STFCR-22032-16	40	22,0	32	0	-10	0,2	TC..16T3..
		GL32-STFCL-22032-16	40	22,0	32	0	-10	0,2	TC..16T3..
GL40	16	GL40-STFCR-27032-16	50	27,0	32	0	-8	0,2	TC..16T3..
		GL40-STFCL-27032-16	50	27,0	32	0	-8	0,2	TC..16T3..
GL50	16	GL50-STFCR-32032-16	63	32,0	32	0	-8	0,3	TC..16T3..
		GL50-STFCL-32032-16	63	32,0	32	0	-8	0,3	TC..16T3..

Spare Parts, Parts included in delivery

Accessories*

For size	Insert key	Insert screw	Insert shim	Shim screw	Shim key
..16	 T15P-2	 C03509-T15P	 STN160312	 CA3510	 9/64SMS875

Please check availability in current price and stock-list

*To be ordered separately

Toolholders for inserts CNGG, CNMA, CNMG and CNMM

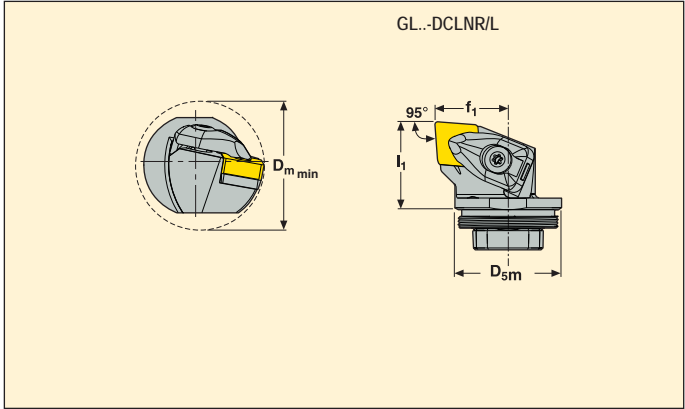
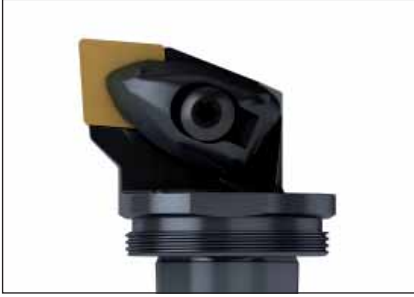

- For insert programme, see page(s) 348-355, 402-403, 431
- γ_o° = Rake angle, λ_s° = Inclination angle
- For holder code key, see page(s) 12-13
- For damping holders programme, see page(s) 304-305

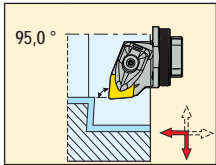

Size		Part No.	Dimensions in mm			γ_o°	λ_s°		
			D_m min	f_1	l_1				
GL32	12	GL32-DCLNR-22032-12	40	22,0	32	-6	-10	0,2	CN..1204..
		GL32-DCLNL-22032-12	40	22,0	32	-6	-10	0,2	CN..1204..
GL40	12	GL40-DCLNR-27032-12	50	27,0	32	-6	-10	0,2	CN..1204..
		GL40-DCLNL-27032-12	50	27,0	32	-6	-10	0,2	CN..1204..
GL50	12	GL50-DCLNR-32032-12	63	32,0	32	-6	-8	0,3	CN..1204..
		GL50-DCLNL-32032-12	63	32,0	32	-6	-8	0,3	CN..1204..
	16	GL50-DCLNR-32037-16	63	32,0	37	-5	-14	0,4	CN..1606..
		GL50-DCLNL-32037-16	63	32,0	37	-5	-14	0,4	CN..1606..
	19	GL50-DCLNR-32040-19	63	32,0	40	-5	-14	0,4	CN..1906..
		GL50-DCLNL-32040-19	63	32,0	40	-5	-14	0,4	CN..1906..

Spare Parts, Parts included in delivery

Accessories*

For size	Clamp pin	Clamp screw	Floating wedge clamp	Insert shim	Shim/clamp key	Shim screw	Spring	Clamp kit
...12	FP2012	L85021-T15P	CD12-S	DCO120310	T15P-7	C04008-T15P	S6912	CD12-S12
...16	FP2012	L86026-T20P	CD16-S	DCN160616	T20P-7L	C05010-T20P	S7010	CD16-S16
...19	FP2012	L86026-T20P	CD19-S	DCN190416	T20P-7L	C05010-T20P	S7010	CD19-S19

Please check availability in current price and stock-list

*To be ordered separately

Toolholders for inserts DCGT, DCGW, DCMT, and DCMX

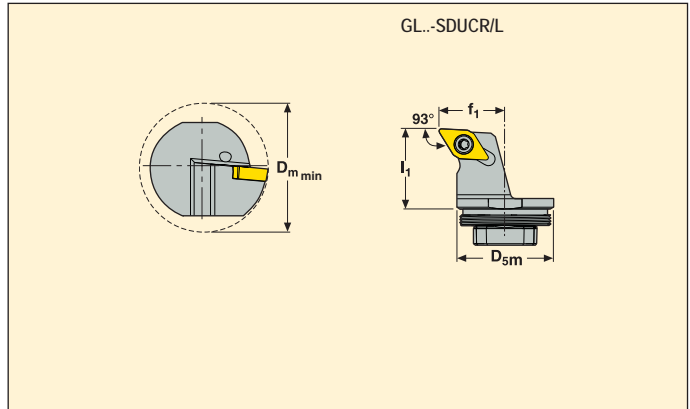

- For insert programme, see page(s) 356-359, 404, 433
- γ_0° = Rake angle, λ_s° = Inclination angle
- For holder code key, see page(s) 12-13
- For damping holders programme, see page(s) 304-305

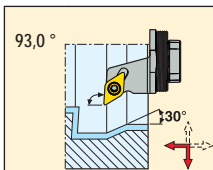

Size	Part No.	Dimensions in mm			γ_0°	λ_s°	KG	Key
		D _m min	f ₁	l ₁				
GL32	GL32-SDUCR-22032-11	40	22,0	32	0	-5	0,1	DC..11T3..
	GL32-SDUCL-22032-11	40	22,0	32	0	-5	0,1	DC..11T3..
GL40	GL40-SDUCR-27032-11	50	27,0	32	0	-5	0,2	DC..11T3..
	GL40-SDUCL-27032-11	50	27,0	32	0	-5	0,2	DC..11T3..
GL50	GL50-SDUCR-32032-11	63	32,0	32	0	-5	0,3	DC..11T3..
	GL50-SDUCL-32032-11	63	32,0	32	0	-5	0,3	DC..11T3..

Spare Parts, Parts included in delivery

For size	Insert key	Insert screw
..-11	T15P-2	C04008-T15P

Please check availability in current price and stock-list

Toolholders for inserts DNGG, DNGM, DNMA, DNMG, DNMM, DNMU and DNMX

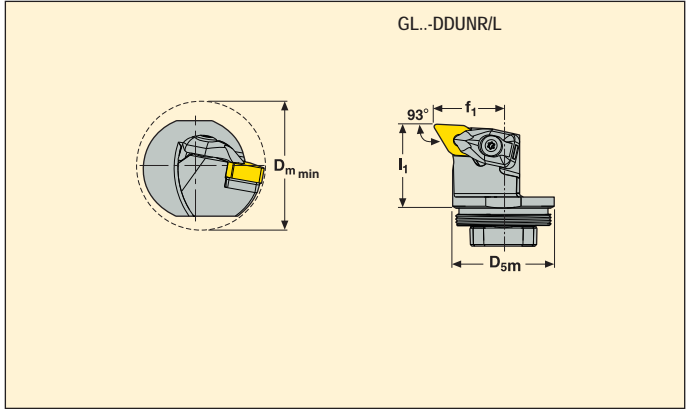

- For insert programme, see page(s) 359-365, 406-408
- γ_o° = Rake angle, λ_s° = Inclination angle
- For holder code key, see page(s) 12-13
- For damping holders programme, see page(s) 304-305

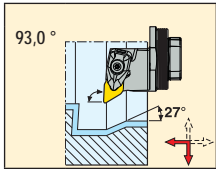

Size	Part No.	Dimensions in mm			γ_o°	λ_s°	KG	
		D_m min	f_1	l_1				
GL32	11 GL32-DDUNR-22032-11	40	22,0	32	-6	-10	0,2	DN..1104..
	GL32-DDUNL-22032-11	40	22,0	32	-6	-10	0,2	DN..1104..
GL40	11 GL40-DDUNR-27032-11	50	27,0	32	-5	-10	0,2	DN..1104..
	GL40-DDUNL-27032-11	50	27,0	32	-5	-10	0,2	DN..1104..
	15 GL40-DDUNR-27032-15	50	27,0	32	-6	-12	0,2	DN..1504..
	GL40-DDUNL-27032-15	50	27,0	32	-6	-12	0,2	DN..1504..
GL50	15 GL50-DDUNR-32032-15	50	27,0	32	-6	-12	0,3	DN..1504..
	GL50-DDUNL-32032-15	50	27,0	32	-6	-12	0,3	DN..1504..

Spare Parts, Parts included in delivery

Accessories*

For size	Clamp pin	Clamp screw	Floating wedge clamp	Insert shim	Shim/clamp key	Shim screw	Spring	Clamp kit
...11	FP1508	L84017-T09P	CD09-S	DDN110310	T09P-2	C03007-T09P	S5608	CD09-S09
...15	FP2012	L85021-T15P	CD12-S	DDN150416	T15P-7	C04008-T15P	S6912	CD12-S12

Please check availability in current price and stock-list

*To be ordered separately

Toolholders for PCBN inserts RNGN-LF, RNGN and RNMM

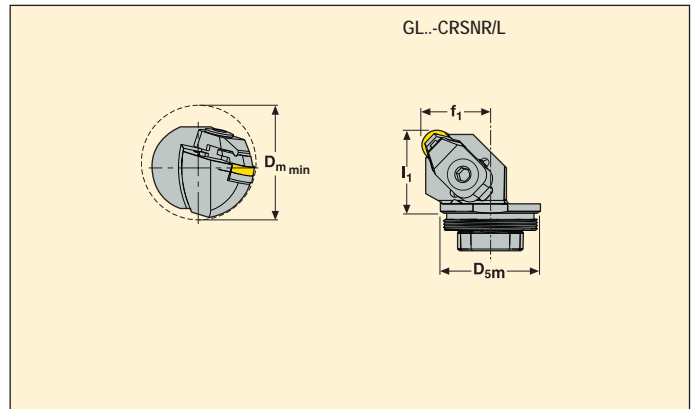

- For insert programme, see page(s) 409-411
- γ_o° = Rake angle, λ_s° = Inclination angle
- For holder code key, see page(s) 12-13
- For damping holders programme, see page(s) 304-305

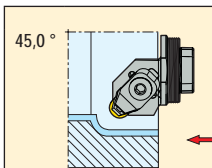

Size	Part No.	Dimensions in mm			γ_o°	λ_s°	KG	●
		D _m min	f ₁	l ₁				
GL32	GL32-CRSNR-22032-09	40	22.0	32	-6	-12	0.2	RN.N0903..
	GL32-CRNL-22032-09	40	22,0	32	-6	-12	0,2	RN.N0903..

Spare Parts, Parts included in delivery

Accessories*

For size	Cantilever clamp	Clamp key	Insert shim	Pressure plate	Shim screw	Shim key
...09	CC17P-09	4SMS795	117.10-620	P1311-09	174.10-652-T07P	T07P-2

Please check availability in current price and stock-list

*To be ordered separately

Toolholders for inserts WNGG, WNMA, WNMG and WNMM



- For insert programme, see page(s) 395-399, 429-430
- γ_0° = Rake angle, λ_s° = Inclination angle
- For holder code key, see page(s) 12-13
- For damping holders programme, see page(s) 304-305

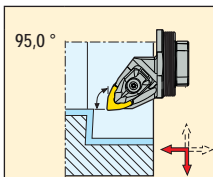
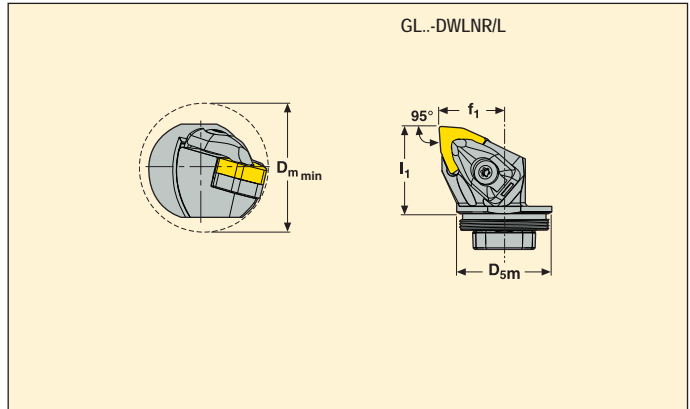

Size	Part No.	Dimensions in mm			γ_0°	λ_s°	KG	Icon	
		D_m min	f_1	l_1					
GL32	06	GL32-DWLNR-22032-06	40	22,0	32	-5	-12	0,2	WN..0604..
		GL32-DWLNL-22032-06	40	22,0	32	-5	-12	0,2	WN..0604..
	08	GL32-DWLNR-22035-08	40	22,0	35	-5	-14	0,2	WN..0804..
		GL32-DWLNL-22035-08	40	22,0	35	-5	-14	0,2	WN..0804..
GL40	06	GL40-DWLNR-27032-06	50	27,0	32	-5	-12	0,2	WN..0604..
		GL40-DWLNL-27032-06	50	27,0	32	-5	-12	0,2	WN..0604..
	08	GL40-DWLNR-27037-08	50	27,0	37	-5	-12	0,2	WN..0804..
		GL40-DWLNL-27037-08	50	27,0	37	-5	-12	0,2	WN..0804..
GL50	06	GL50-DWLNR-32032-06	63	32,0	32	-5	-12	0,3	WN..0604..
		GL50-DWLNL-32032-06	63	32,0	32	-5	-12	0,3	WN..0604..
	08	GL50-DWLNR-32038-08	63	32,0	38	-5	-12	0,3	WN..0804..
		GL50-DWLNL-32038-08	63	32,0	38	-5	-12	0,3	WN..0804..

Spare Parts, Parts included in delivery

Accessories*

For size	Clamp pin	Clamp screw	Floating wedge clamp	Insert shim	Shim/clamp key	Shim screw	Spring	Clamp kit
...06	FP1508	L84017-T09P	CD09-S	DWN060310	T09P-2	C03007-T09P	S5608	CD09-S09
...08	FP2012	L85021-T15P	CD12-S	DWN080416	T15P-7	C04008-T15P	S6912	CD12-S12

Please check availability in current price and stock-list

*To be ordered separately

Toolholders for inserts CCGW, CCGX, CCMT and CCMW



- For insert programme, see page(s) 343-347, 400, 432
- γ_0° = Rake angle, λ_s° = Inclination angle
- For holder code key, see page(s) 10-11

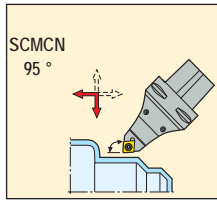
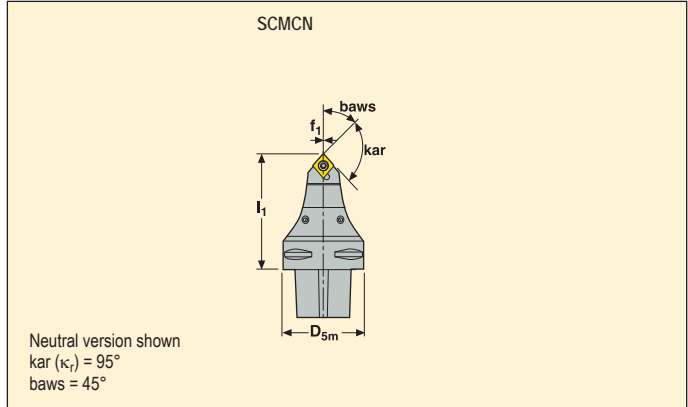

Capto size	Part No.	Dimensions in mm			γ_0°	λ_s°	KG	Key	
		D _{5m}	f ₁	l ₁					
C6	12	C6-SCMCN-00090-12	63	0	90	0	0	1,2	CC..1204..

Spare Parts, Parts included in delivery

For size	Insert key	Insert screw	Insert shim	Shim screw	Shim key
...-12	T15P-2	C05012-T15P	123.19-621	CA5008	5SMS795

Accessories, to be ordered separately

Please check availability in current price and stock-list

Toolholders for inserts WNGA, WNMA, WNMG and WNMM



- For insert programme, see page(s) 396-399, 429
- γ_0° = Rake angle, λ_s° = Inclination angle
- For holder code key, see page(s) 10-11

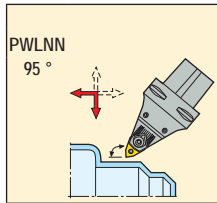
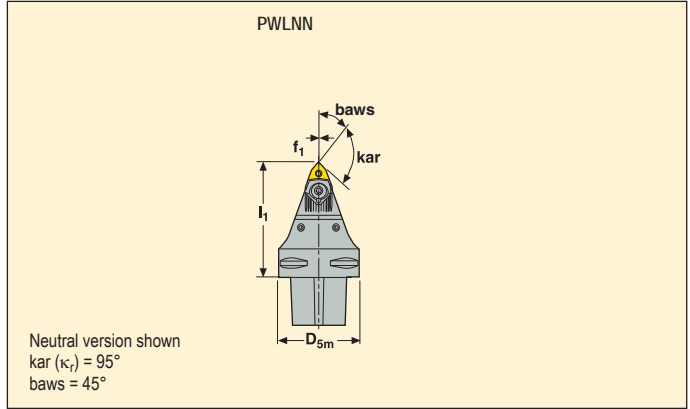

Capto size	Part No.	Dimensions in mm			γ_0°	λ_s°	KG	Icon
		D _{5m}	f ₁	I ₁				
C6	08 C6-PWLNN-00090-08	63	0	90	-5,5	-6,5	1,4	WN..0804..

Spare Parts, Parts included in delivery

Accessories*

For size	Insert shim	Setting screw	Shim pin	Wedge clamp	Wedge key	Wedge screw	Shim key
...-08	WAE080412	L82511-T07P	PP2015-1-T15P	WNW08HD	T25P-7	WS2325-T25P	T15P-2

Please check availability in current price and stock-list

*To be ordered separately
Shim WAE080312 for insert WNM.0806.., to be ordered separately
Wedge WNW08 for insert WNM08.., to be ordered separately

Toolholders for inserts CCGT, CCGW, CCMT and CCMW



- For insert programme, see page(s) 343-347, 400-401, 431-432
- γ_0° = Rake angle, λ_s° = Inclination angle
- For holder code key, see page(s) 14-15

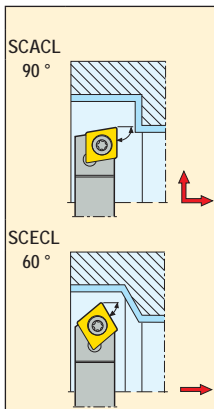
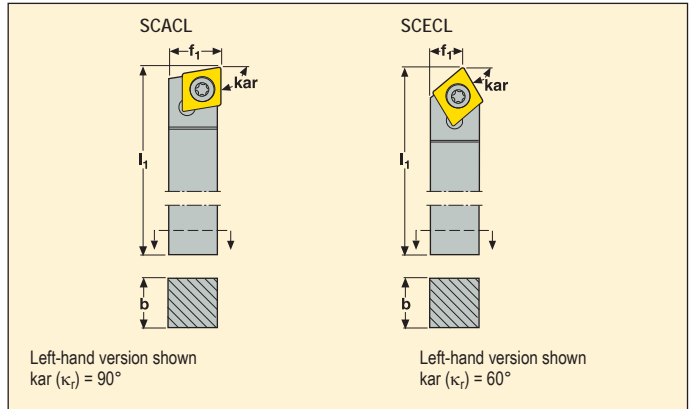

Part No.	Dimensions in mm					γ_0°	λ_s°	KG	
	h	b	l_1	f_1	l_3				
09 SCACL 1212D09	12	12	60	13,0	13	0	0	0,1	CC..09T3..
06 SCECL 0808A06	8	8	32	5,2	11	0	0	0,1	CC..0602..
	1010C06	10	10	50	6,2	11	0	0	0,1

Spare Parts, Parts included in delivery

For size	Insert key	Insert screw
...06	T07P-2	C02506-T07P
...09	T15P-2	C04008-T15P

Please check availability in current price and stock-list

Toolholders for inserts CCGT, CCGW, CCMT and CCMW



- For insert programme, see page(s) 343-347, 400-401, 431-432
- γ_0° = Rake angle, λ_s° = Inclination angle
- For holder code key, see page(s) 16-17

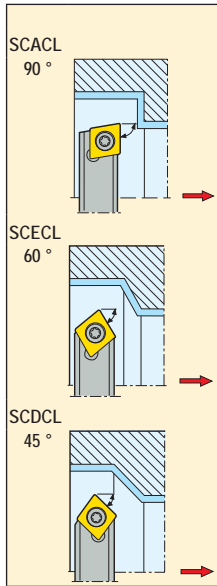
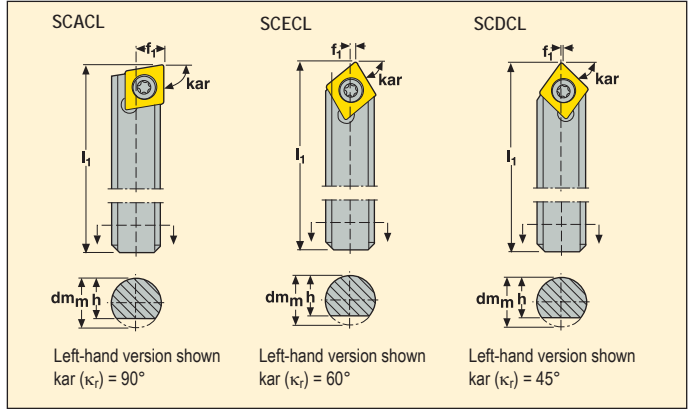

Part No.	Dimensions in mm				γ_0°	λ_s°	KG	Insert	
	d_{m_m}	h	l_1	f_1					
06	S08A-SCACL06	8	6,3	32	4,2	0	0	0,1	CC..0602..
	S10C-SCACL06	10	8,3	50	5,2	0	0	0,1	CC..0602..
09	S12D-SCACL09	12	10,3	60	6,7	0	0	0,1	CC..09T3..
06	S08A-SCECL06	8	6,3	32	1,5	0	0	0,1	CC..0602..
	S10C-SCECL06	10	8,3	50	2,4	0	0	0,1	CC..0602..
09	S12D-SCECL09	12	10,3	60	2,3	0	0	0,1	CC..09T3..
06	S08A-SCDCL06	8	6,3	32	,3	0	0	0,1	CC..0602..
	S10C-SCDCL06	10	8,3	50	1,2	0	0	0,1	CC..0602..
09	S12D-SCDCL09	12	10,3	60	,5	0	0	0,1	CC..09T3..

Spare Parts, Parts included in delivery

For size	Insert key	Insert screw
S08A-...06	T07P-2	C02505-T07P
S10C-...06	T07P-2	C02506-T07P
...09	T15P-2	C04008-T15P

Please check availability in current price and stock-list

Cartridges for inserts CCGT, CCGW, CCGX, CCMT and CCMW



- For insert programme, see page(s) 343-347, 400-401, 431-432
- γ_0° = Rake angle, λ_s° = Inclination angle

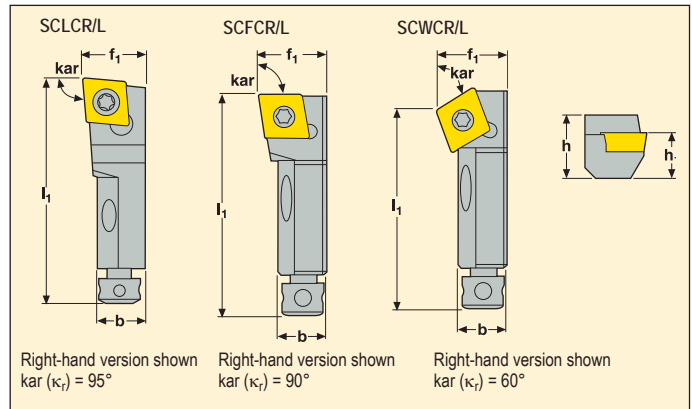

SCLCR/L 95°		Part No.	Dimensions in mm					D_m min	γ_0°	λ_s°	KG	
			h	b	l_1	f_1	h_1					
09		SCLCR10CA-09	15	11	50	14	10	40	0	0	0,1	CC..09T3..
		SCLCL10CA-09	15	11	50	14	10	40	0	0	0,1	CC..09T3..
12		SCLCR12CA-12	20	16	55	20	12	50	0	0	0,1	CC..1204..
		SCLCL12CA-12	20	16	55	20	12	50	0	0	0,1	CC..1204..
06		SCFCR08CA-06	11	7	32	10	8	25	0	0	0,1	CC..0602..
		SCFCL08CA-06	11	7	32	10	8	25	0	0	0,1	CC..0602..
09		SCFCR10CA-09	15	11	50	14	10	40	0	0	0,1	CC..09T3..
		SCFCL10CA-09	15	11	50	14	10	40	0	0	0,1	CC..09T3..
12		SCFCR12CA-12	20	16	55	20	12	50	0	0	0,1	CC..1204..
		SCFCL12CA-12	20	16	55	20	12	50	0	0	0,1	CC..1204..
06		SCWCR08CA-06	11	7	28	10	8	25	0	0	0,1	CC..0602..
		SCWCL08CA-06	11	7	28	10	8	25	0	0	0,1	CC..0602..
09		SCWCR10CA-09	15	11	44	14	10	40	0	0	0,1	CC..09T3..
		SCWCL10CA-09	15	11	44	14	10	40	0	0	0,1	CC..09T3..
12		SCWCR12CA-12	20	16	47	20	12	50	0	0	0,1	CC..1204..
		SCWCL12CA-12	20	16	47	20	12	50	0	0	0,1	CC..1204..

Spare Parts, Parts included in delivery

For size	Insert key	Insert screw	Locking screw	Setting screw (axial)	Setting screw (radial)
-06	T07P-2	C02505-T07P	179.17-698-T09P	179.17-683	179.17-684
-09	T15P-2	C04008-T15P	179.17-696-T25P	179.17-680	179.17-686
-12	T20P-7	C05010-T20P	179.17-697-T25P	179.17-680	179.17-687

Accessories*

Locking key	Setting key
T09P-2	1.5SMS795
T25P-7	2SMS795
T25P-7	2SMS795

Please check availability in current price and stock-list

*To be ordered separately

Cartridges for inserts CCGT, CCGW, CCMT and CCMW



- For insert programme, see page(s) 343-347, 400-401, 431-432
- γ_0° = Rake angle, λ_s° = Inclination angle

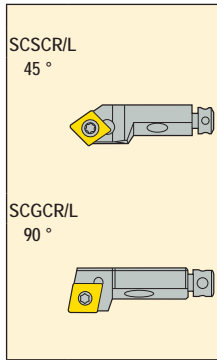
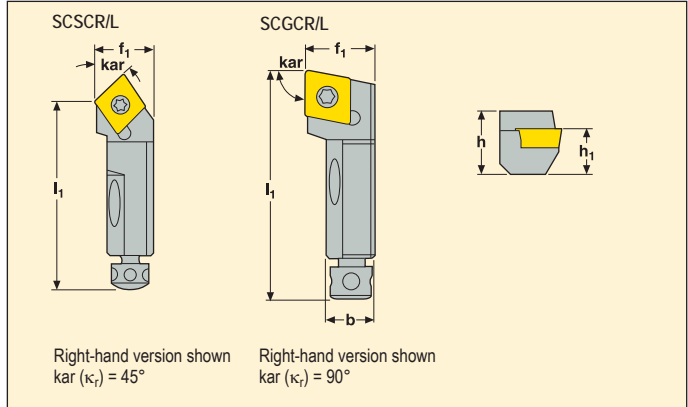

Part No.	Dimensions in mm							γ_0°	λ_s°	KG	Insert
	h	b	l_1	f_1	h_1	D_m min					
06	SCSCR08CA-06	11	7	28	10	8	25	0	0	0,1	CC..0602..
	SCSCL08CA-06	11	7	28	10	8	25	0	0	0,1	CC..0602..
09	SCSCR10CA-09	15	11	44	14	10	40	0	0	0,1	CC..09T3..
	SCSCL10CA-09	15	11	44	14	10	40	0	0	0,1	CC..09T3..
12	SCSCR12CA-12	20	16	47	20	12	50	0	0	0,1	CC..1204..
	SCSCL12CA-12	20	16	47	20	12	50	0	0	0,1	CC..1204..
06	SCGCR08CA-06	11	7	32	10	8	25	0	0	0,1	CC..0602..
	SCGCL08CA-06	11	7	32	10	8	25	0	0	0,1	CC..0602..
09	SCGCR10CA-09	15	11	50	14	10	40	0	0	0,1	CC..09T3..
	SCGCL10CA-09	15	11	50	14	10	40	0	0	0,1	CC..09T3..
12	SCGCR12CA-12	20	16	55	20	12	50	0	0	0,1	CC..1204..
	SCGCL12CA-12	20	16	55	20	12	50	0	0	0,1	CC..1204..

Spare Parts, Parts included in delivery

For size	Insert key	Insert screw	Locking screw	Setting screw (axial)	Setting screw (radial)
-06	T07P-2	C02505-T07P	179.17-698-T09P	179.17-683	179.17-684
-09	T15P-2	C04008-T15P	179.17-696-T25P	179.17-680	179.17-686
-12	T20P-7	C05010-T20P	179.17-697-T25P	179.17-680	179.17-687

Accessories*

Locking key	Setting key
T09P-2	1.5SMS795
T25P-7	2SMS795
T25P-7	2SMS795

Please check availability in current price and stock-list

*To be ordered separately

Cartridges for inserts CCGT, CCGW, CCMT and CCMW



- For insert programme, see page(s) 343-347, 400-401, 431-432
- γ_o° = Rake angle, λ_s° = Inclination angle

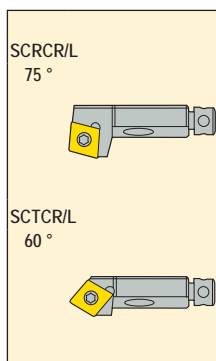
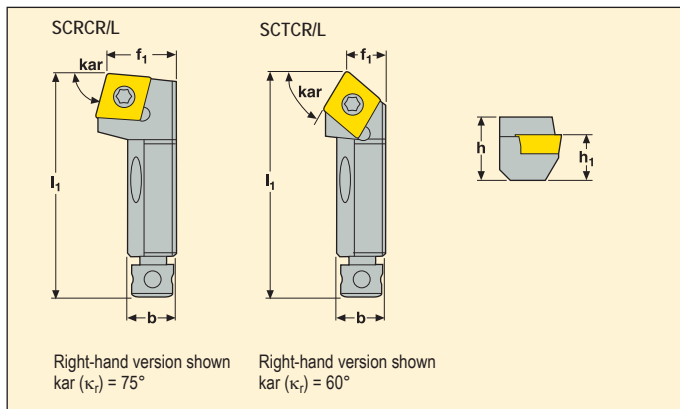

	Part No.	Dimensions in mm						γ_o°	λ_s°	KG	
		h	b	l_1	f_1	h_1	D_m min				
06	SCRCR08CA-06	11	7	32	10	8	25	0	0	0,1	CC..0602..
	SCRCL08CA-06	11	7	32	10	8	25	0	0	0,1	CC..0602..
09	SCRCR10CA-09	15	11	50	14	10	40	0	0	0,1	CC..09T3..
	SCRCL10CA-09	15	11	50	14	10	40	0	0	0,1	CC..09T3..
12	SCRCR12CA-12	20	16	55	20	12	50	0	0	0,1	CC..1204..
	SCRCL12CA-12	20	16	55	20	12	50	0	0	0,1	CC..1204..
06	SCTCR08CA-06	11	7	32	6	8	25	0	0	0,1	CC..0602..
	SCTCL08CA-06	11	7	32	6	8	25	0	0	0,1	CC..0602..
09	SCTCR10CA-09	15	11	50	9	10	40	0	0	0,1	CC..09T3..
	SCTCL10CA-09	15	11	50	9	10	40	0	0	0,1	CC..09T3..
12	SCTCR12CA-12	20	16	55	13	12	50	0	0	0,1	CC..1204..
	SCTCL12CA-12	20	16	55	13	12	50	0	0	0,1	CC..1204..

Spare Parts, Parts included in delivery

For size	Insert key	Insert screw	Locking screw	Setting screw (axial)	Setting screw (radial)
-06	T07P-2	C02505-T07P	179.17-698-T09P	179.17-683	179.17-684
-09	T15P-2	C04008-T15P	179.17-696-T25P	179.17-680	179.17-686
-12	T20P-7	C05010-T20P	179.17-697-T25P	179.17-680	179.17-687

Accessories*

Locking key	Setting key
T09P-2	1.5SMS795
T25P-7	2SMS795
T25P-7	2SMS795

Please check availability in current price and stock-list

*To be ordered separately

Cartridges for inserts SCGW and SCMT



- For insert programme, see page(s) 372, 412
- γ_0° = Rake angle, λ_s° = Inclination angle

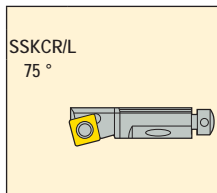
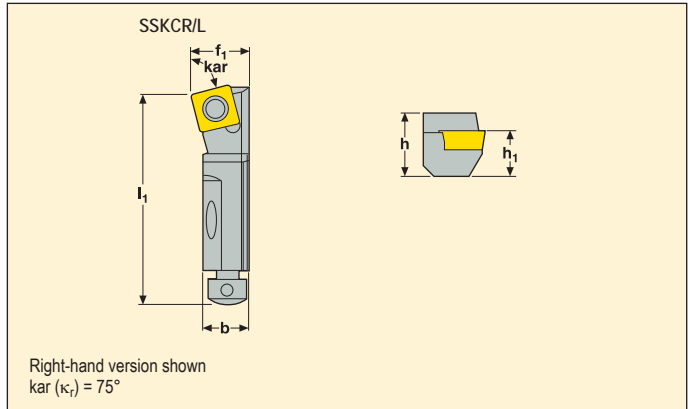

Part No.	Dimensions in mm							γ_0°	λ_s°	KG	
	h	b	l_1	f_1	h_1	D_m min					
09	SSKCR 10CA-09	15	11	50	14	10	40	0	0	0,1	SC..09T3..
	SSKCL 10CA-09	15	11	50	14	10	40	0	0	0,1	SC..09T3..
12	SSKCR 12CA-12	20	16	55	20	12	50	0	0	0,1	SC..1204..
	16CA-12	25	20	63	25	16	60	0	-4	0,2	SC..1204..
	SSKCL 12CA-12	20	16	55	20	12	50	0	0	0,1	SC..1204..
	16CA-12	25	20	63	25	16	60	0	-4	0,2	SC..1204..

Spare Parts, Parts included in delivery

Accessories*

For size	Insert key	Insert screw	Insert shim	Locking screw	Setting screw (axial)	Setting screw (radial)	Shim screw	Locking key	Setting key
.09	T15P-2	C04008-T15P	–	179.17-696-T25P	179.17-680	179.17-686	–	T25P-7	2SMS795
.12...12	T20P-7	C05010-T20P	–	179.17-697-T25P	179.17-680	179.17-687	–	5SMS795	2.5SMS795
.16...12	T15P-2	C05012-T15P	110.19-621	179.17-693	179.17-680	179.17-685	CA5008	T25P-7	2SMS795

Please check availability in current price and stock-list

*To be ordered separately

Cartridges for inserts TCGT, TCMT and TCMW



- For insert programme, see page(s) 380-383, 419, 434
- γ_0° = Rake angle, λ_s° = Inclination angle

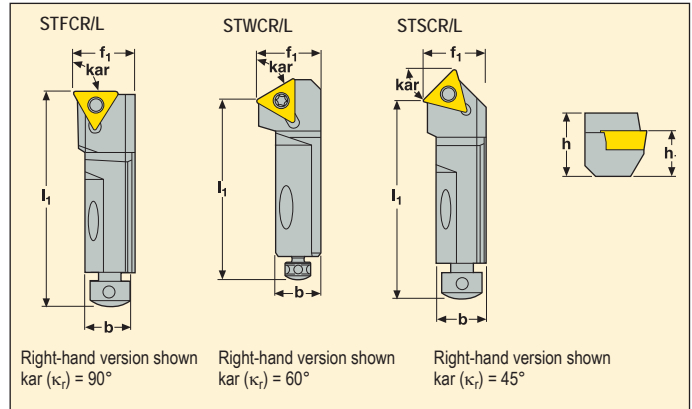

STFCR/L 90°	Part No.	Dimensions in mm						γ_0°	λ_s°	KG	TC..1102..
		h	b	l_1	f_1	h_1	D_m min				
11	STFCR 10CA-11	15	11	50	14	10	40	0	0	0,1	TC..1102..
	12CA-11	20	16	55	20	12	50	0	0	0,1	TC..1102..
	STFCL 10CA-11	15	11	50	14	10	40	0	0	0,1	TC..1102..
16	STFCR 16CA-16	25	20	63	25	16	60	0	-2	0,2	TC..16T3..
	STFCL 16CA-16	25	20	63	25	16	60	0	-2	0,2	TC..16T3..
16	STWCR 16CA-16	25	20	53	25	16	60	0	0	0,2	TC..16T3..
	STWCL 16CA-16	25	20	53	25	16	60	0	0	0,2	TC..16T3..
11	STSCR 10CA-11	15	11	44	14	10	40	0	0	0,1	TC..1102..
	STSCL 10CA-11	15	11	44	14	10	40	0	0	0,1	TC..1102..
16	STSCR 12CA-16	20	16	47	20	12	50	0	0	0,1	TC..16T3..
	16CA-16	25	20	53	25	16	60	-9	0	0,2	TC..16T3..
	STSCCL 12CA-16	20	16	47	20	12	50	0	0	0,1	TC..16T3..
	16CA-16	25	20	53	25	16	60	-9	0	0,2	TC..16T3..

Spare Parts, Parts included in delivery

For size	Insert key	Insert screw	Insert shim	Locking screw	Setting screw (axial)	Setting screw (radial)	Shim screw
..10...11	T07P-2	C02506-T07P	-	179.17-696-T25P	179.17-680	179.17-686	-
..12...11	T07P-2	C02506-T07P	-	179.17-697-T25P	179.17-680	179.17-687	-
..12...16	T15P-2	C03509-T15P	-	179.17-697-T25P	179.17-680	179.17-687	-
..16...16	T15P-2	C03509-T15P	STN160312	179.17-693	179.17-680	179.17-685	CA3510

Accessories*

Locking key	Setting key	Shim key
T25P-7	2SMS795	-
T25P-7	2SMS795	-
T25P-7	2SMS795	-
5SMS795	2.5SMS795	9/64SMS875

Please check availability in current price and stock-list

*To be ordered separately

Cartridges for inserts TCGT, TCGW, TCMT and TCMW



- For insert programme, see page(s) 380-383, 419, 434
- γ_0° = Rake angle, λ_s° = Inclination angle

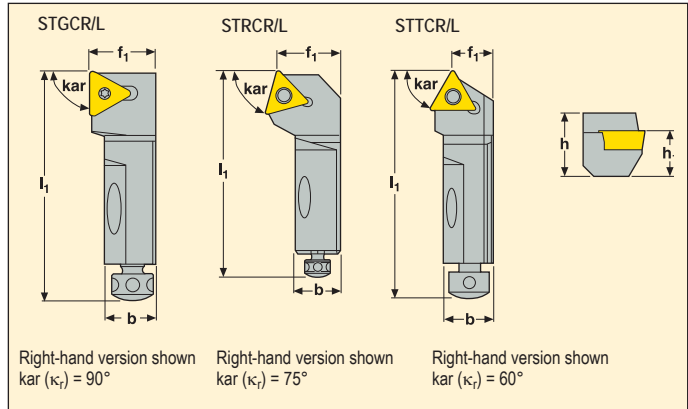

STGCR/L 90°	Part No.	Dimensions in mm						γ_0°	λ_s°	KG	TC..
		h	b	l_1	f_1	h_1	D_m min				
	11 STGCR 10CA-11	15	11	50	14	10	40	0	0	0,1	TC..1102..
STRCR/L 75°	16 STGCR 12CA-16	20	16	55	20	12	50	0	0	0,1	TC..16T3..
	16 16CA-16	25	20	63	25	16	50	-5	0	0,2	TC..16T3..
	16 STGCL 12CA-16	20	16	55	20	12	50	0	0	0,1	TC..16T3..
	16 16CA-16	25	20	63	25	16	50	-5	0	0,2	TC..16T3..
STTCR/L 60°	22 STGCL 16CA-22	20	18	63	25	16	70	0	0	0,2	TC..2204..
	16 STRCR 16CA-16	25	20	63	25	16	60	-5	0	0,2	TC..16T3..
	16 STRCL 16CA-16	25	20	63	25	16	60	-5	0	0,2	TC..16T3..
	22 STRCL 16CA-22	20	18	63	25	16	70	0	0	0,2	TC..2204..
11	11 STTCR 10CA-11	15	11	50	9	10	40	0	0	0,1	TC..1102..
	11 STTCL 10CA-11	15	11	50	9	10	40	0	0	0,1	TC..1102..
16	16 STTCR 12CA-16	20	16	55	13	12	50	0	0	0,1	TC..16T3..
	16 16CA-16	25	20	63	15	16	60	-4	0	0,2	TC..16T3..
	16 STTCL 12CA-16	20	16	55	13	12	50	0	0	0,1	TC..16T3..
	16 16CA-16	25	20	63	15	16	60	-4	0	0,2	TC..16T3..

Spare Parts, Parts included in delivery

For size	Insert key	Insert screw	Insert shim	Locking screw	Setting screw (axial)	Setting screw (radial)	Shim screw
..10..11	T07P-2	C02506-T07P	-	179.17-696-T25P	179.17-680	179.17-686	-
..12..16	T15P-2	C03509-T15P	-	179.17-697-T25P	179.17-680	179.17-687	-
..16..16	T15P-2	C03509-T15P	STN160312	179.17-693	179.17-680	179.17-685	CA3510
..16..22	T15P-2	C05012-T15P	-	179.17-693	179.17-680	179.17-690-T15P	-

Accessories*

Locking key	Setting key	Shim key
T25P-7	2SMS795	-
T25P-7	2SMS795	-
5SMS795	2.5SMS795	9/64SMS875
5SMS795	2SMS795	-

Please check availability in current price and stock-list

*To be ordered separately

Toolholders for inserts LNMX



- For insert programme, see page(s) 366

Cassettes for re-machining operations

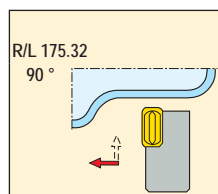
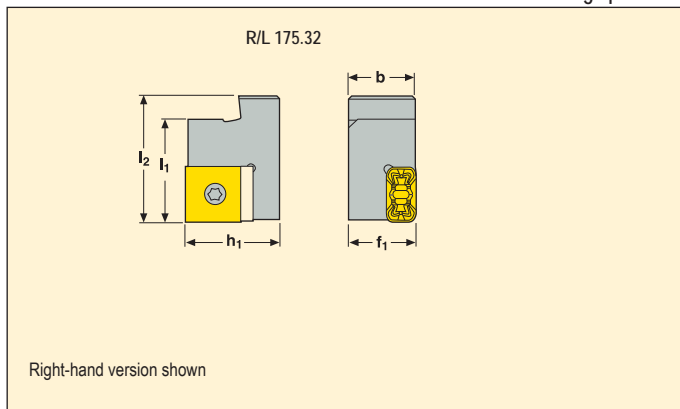

	Part No.	Dimensions in mm					KG	
		h ₁	b	l ₂	l ₁	f ₁		
19	R175.32-3223-19	32	22,6	42,2	35	23	0,2	LNMX191940
	L175.32-3223-19	32	22,6	42,2	35	23	0,2	LNMX191940
30	R175.32-3223-30	32	22,6	42,2	35	23	0,2	LNMX301940
	L175.32-3223-30	32	22,6	42,2	35	23	0,2	LNMX301940

Spare Parts, Parts included in delivery

For size	Insert key	Insert screw	Insert shim	Shim screw
...-19	T15P-2	MN1515SL-T15P	LN190450	174.10-650.9-T07P
...-30	T15P-2	MN1515SL-T15P	LN300450	174.10-650.9-T07P

Accessories, to be ordered separately

Shim key
T07P-2
T07P-2

Please check availability in current price and stock-list

Toolholders for inserts LNMX



• For insert programme, see page(s) 366

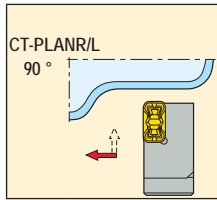
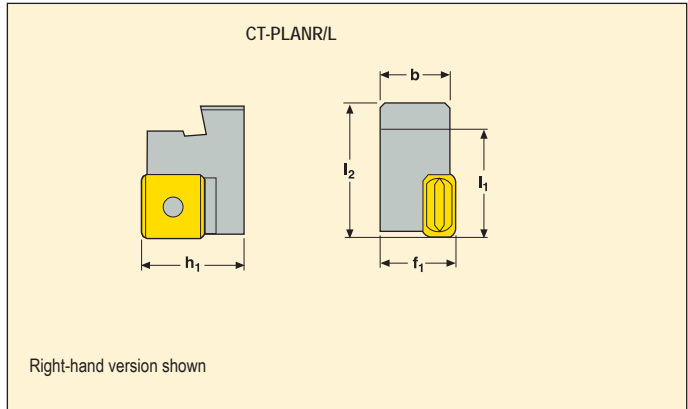

	Part No.	Dimensions in mm					KG	[Insert icon]
		h_1	b	l_2	l_1	f_1		
19	CT-PLANR3223-19	32	23	42,2	35	23	0,2	LNMX191940
	CT-PLANL3223-19	32	23	42,2	35	23	0,2	LNMX191940

Spare Parts, Parts included in delivery

Accessories, to be ordered separately

For size	Insert key	Insert screw	Insert shim	Shim screw	Shim key
...-19	T15P-2	MN1515SL-T15P	LN190450	174.10-650.9-T07P	T07P-2

Please check availability in current price and stock-list

Toolholders for inserts LNMX



• For insert programme, see page(s) 366

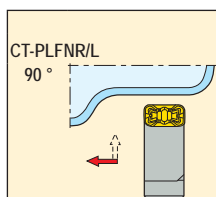
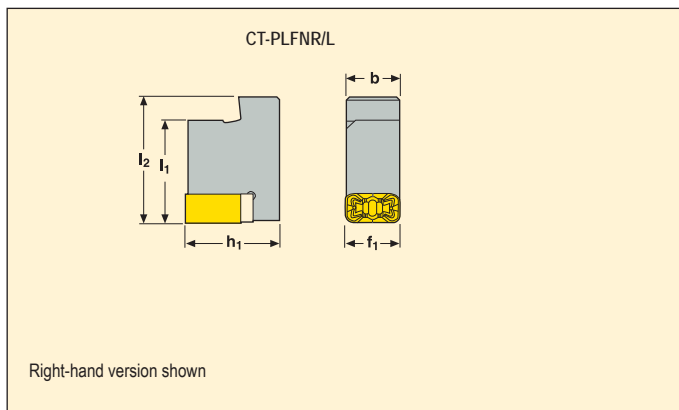

	Part No.	Dimensions in mm					KG	
		h_1	b	l_2	l_1	f_1		
19	CT-PLFNR3219-19	32	18	43,0	35	19	0,2	LNMX191940
	CT-PLFNL3219-19	32	18	43,0	35	19	0,2	LNMX191940

Spare Parts, Parts included in delivery

For size	Insert key	Insert screw	Insert shim	Shim screw
...-19	T15P-2	MN1515SL-T15P	LN190450	174.10-650.9-T07P

Accessories, to be ordered separately

Shim key
T07P-2

Please check availability in current price and stock-list

Toolholders for inserts SNMX



• For insert programme, see page(s) 379

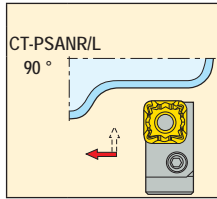
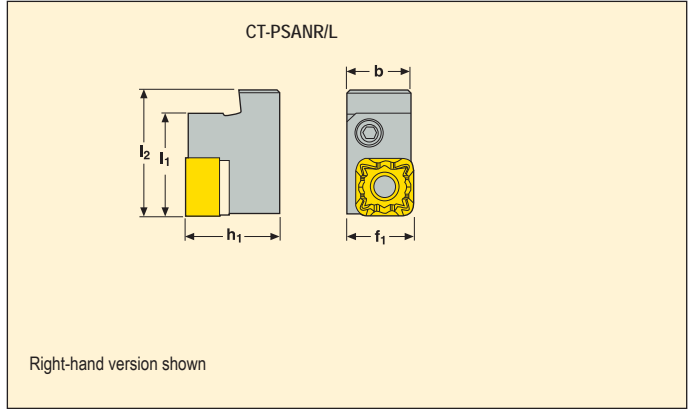

Part No.	Dimensions in mm					KG	Insert	
	h ₁	b	l ₂	l ₁	f ₁			
19	CT-PSANR3223-1911	32	23	43,0	35	23	0,2	SNMX191140
	CT-PSANL3223-1911	32	23	43,0	35	23	0,2	SNMX191140

Spare Parts, Parts included in delivery

For size	Insert lever	Insert shim	Lever key	Lever screw	Punch	Shim pin
...-1911	PP6020	PSN19X340	4SMS795	LS1030	MP1519	RP9811

Please check availability in current price and stock-list

Turning – Cassettes for railway wheel machining

Toolholders for inserts SNMX

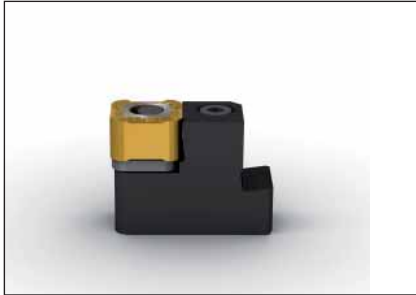

- For insert programme, see page(s) 379

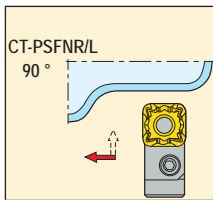
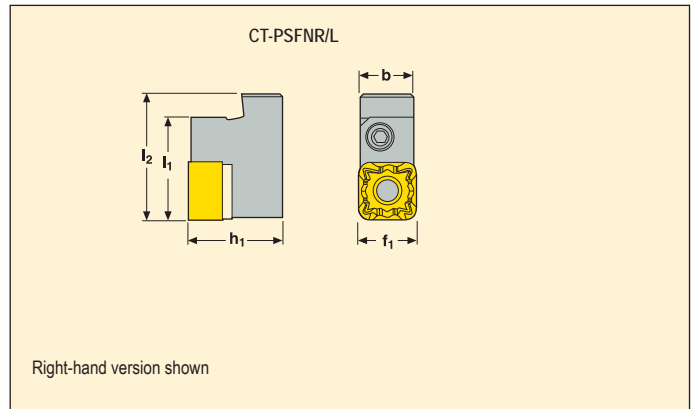

	Part No.	Dimensions in mm					KG	Insert
		h_1	b	l_2	l_1	f_1		
19	CT-PSFNR3219-1911	32	18	43,0	35	19	0,2	SNMX191140
	CT-PSFNL3219-1911	32	18	43,0	35	19	0,2	SNMX191140

Spare Parts, Parts included in delivery

For size	Insert lever	Insert shim	Lever key	Lever screw	Punch	Shim pin
...-1911	PP6020	PSN19X340	4SMS795	LS1030	MP1519	RP9811

Please check availability in current price and stock-list

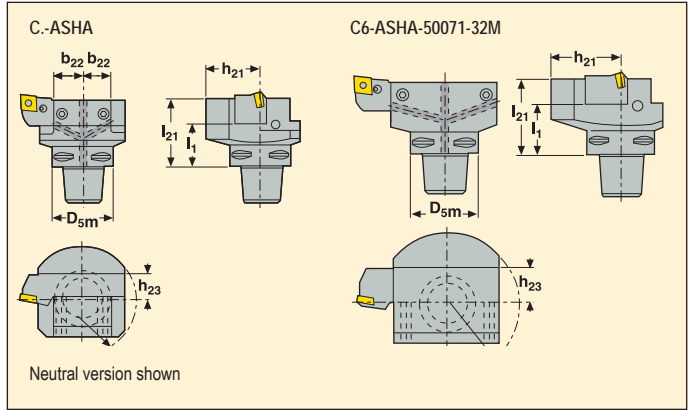

Capto size	Part No.	Dimensions in mm							KG
		D _{5m}	D ₁	b ₂₂	h ₂₁	h ₂₃	l ₁	l ₂₁	
C5	C5-ASHA -38058-20M	50	90,0	23,0	38,0	20,0	38,0	58	1,5
C6	C6-ASHA -38060-20M	63	90,0	23,0	38,0	20,0	40,0	60	1,8
	-45071-25M	63	110,0	30,0	45,0	25,0	45,0	71	2,3
	-50071-32M	63	130,0	NaN	50,0	32,0	45,0	71	3,4
C8	C8-ASHA -55085-32M	80	142,0	40,0	55,0	32,0	63,0	85	5,0

Spare Parts, Parts included in delivery

For size	Bolt	Circlip	Nozzle	O-ring	Screw
C5-	VB23	SGH1510	CN9	ORING-9X2	T6SS10X25
C6...20	VB23	SGH1510	CN9	ORING-9X2	T6SS8X25
C6...25, ...32	VB23	SGH1510	CN9	ORING-9X2	T6SS12X30
C8	VB23	SGH1510	CN9	ORING-9X2	T6SS12X30

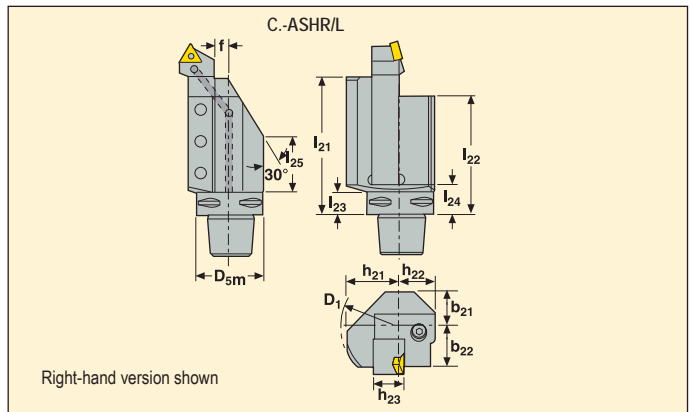

Capto size	Part No.	Dimensions in mm												 KG
		D _{5m}	D ₁	b ₂₁	b ₂₂	f	h ₂₁	h ₂₂	h ₂₃	l ₂₁	l ₂₂	l ₂₃	l ₂₄	
C5	C5-ASHR -30098-20	50	90	29	30	10	41	33	20	98	88	20	23	2,2
	C5-ASHL -30098-20	50	90	29	30	10	41	33	20	98	88	20	23	2,2
C6	C6-ASHR -30100-20	63	90	29	30	10	41	33	20	100	90	22	25	2,5
	-38130-25	63	110	32	38	13	50	33	25	130	112	22	28	3,5
	C6-ASHL -30100-20	63	90	29	30	10	41	33	20	100	90	22	25	1,4
	-38130-25	63	110	32	38	13	50	33	25	130	112	22	28	3,5
C8	C8-ASHR -40140-32	80	110	40	40	8	55	30	32	140	130	30	35	5,2
	C8-ASHL -40140-32	80	110	40	40	8	55	30	32	140	130	30	35	5,5

Spare Parts, Parts included in delivery

For size	Nozzle	Screw
C5	CN10	T6SS10X25
C6..-20	CN10	T6SS8X25
C6..-25	CN10	T6SS12X30
C8	CN10	T6SS12X30

Please check availability in current price and stock-list

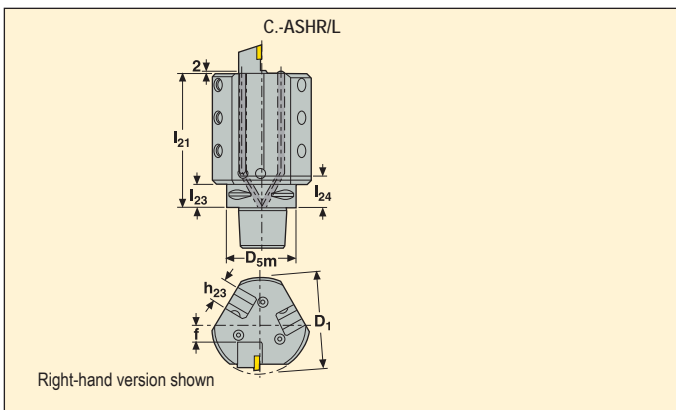

Capto size	Part No.	Dimensions in mm							KG
		D _{5m}	D ₁	f	h ₂₃	l ₂₁	l ₂₃	l ₂₄	
C5	C5-ASHR3-36123-20	50	90	16	20	123	20	26	3,7
	C5-ASHL3-36123-20	50	90	16	20	123	20	26	0,9
C6	C6-ASHR3-36125-20	63	90	16	20	125	22	28	3,8
	C6-ASHL3-36125-20	63	90	16	20	125	22	28	3,8
C8	C8-ASHR3-45150-32	80	120	20	32	150	30	36	7,3
	C8-ASHL3-45150-32	80	120	20	32	150	30	36	6,6

Spare Parts, Parts included in delivery

For size	Nozzle	Screw
C5	CN2	T6SS12X30
C6	CN2	T6SS12X30
C8	CN10	T6SS12X30

Please check availability in current price and stock-list

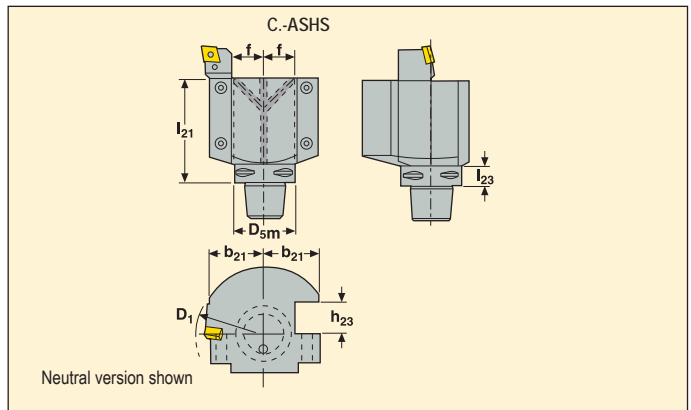

Capto size	Part No.	Dimensions in mm							 KG
		D _{5m}	D ₁	b ₂₁	f	h ₂₃	l ₂₁	l ₂₃	
C6	C6-ASHS-58115-32	63	140	58	3,3	32	115	22	7,4

Spare Parts, Parts included in delivery

For size	Nozzle	Screw
C6	CN9	T6SS12X30

Please check availability in current price and stock-list

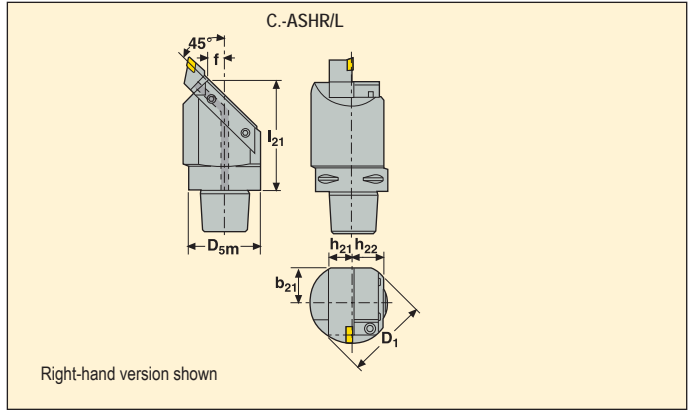

Capto size	Part No.	Dimensions in mm							
		D _{5m}	D ₁	b ₂₁	f	h ₂₁	h ₂₂	l ₂₁	
C5	C5-ASHR45-36097-20	50	72	30,6	15	20	26	97	1,8
	C5-ASHL45-36097-20	50	72	30,6	15	20	26	97	0,9
C6	C6-ASHR45-36099-20	63	72	31,5	15	20	28	99	0,1
	C6-ASHL45-36099-20	63	72	31,5	15	20	28	99	2,2
C8	C8-ASHR45-50135-32	80	140	45,0	17	32	40	135	6,6
	C8-ASHL45-50135-32	80	140	45,0	17	32	40	135	6,6

Spare Parts, Parts included in delivery

For size	Nozzle	Screw
C5	CN9	T6SS10X25
C6	CN9	T6SS8X25
C8	CN9	T6SS12X30

Please check availability in current price and stock-list

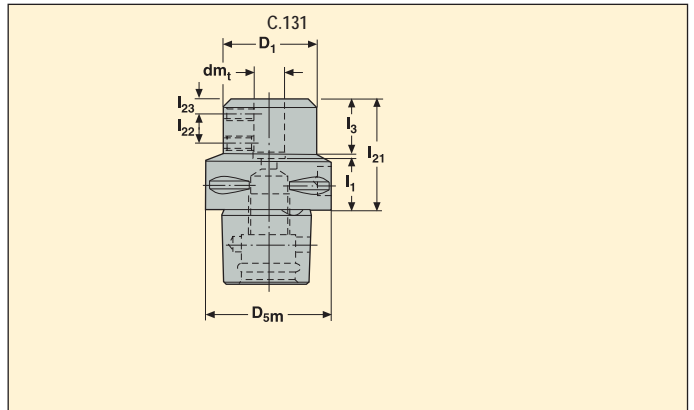

Capto size	Part No.	Dimensions in mm									
		D _{5m}	dm _t	D ₁	I ₁	I ₃	I ₂₁	I ₂₂	I ₂₃		
C3	C3-131 -00035-10	32	10	36	20	20,0	35	10	5	0,24	
	-00040-12	32	12	36	24	24,0	40	12	6	0,29	
C4	C4-131 -00040-10	40	10	36	20	19,0	40	10	5	0,39	
	-00045-12	40	12	36	24	24,0	45	12	6	0,42	
	-00050-16	40	16	36	32	29,0	50	16	8	0,43	
C5	C5-131 -00045-10	50	10	36	20	21,0	45	10	5	0,62	
	-00045-12	50	12	36	24	22,5	45	12	6	0,6	
	-00055-16	50	16	36	32	31,0	55	16	8	0,65	

Spare Parts, Parts included in delivery

For size	Key	Screw
...-10	3SMS795	951C0610
...-12	3SMS795	951C0610
...-16	4SMS795	951C0810

Please check availability in current price and stock-list



• Sleeves, see page(s) 341

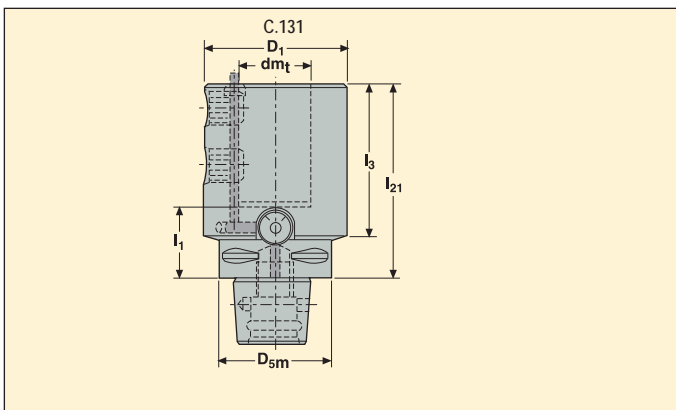

Capto size	Part No.	Dimensions in mm						KG
		D_{5m}	dm_t	D_1	I_1	I_3	I_{21}	
C5	C5-131 -00100-25	50	25	63	43	80	100	2,1
C6	C6-131 -00098-25	63	25	63	41	–	98	2,0
	-00112-40	63	40	80	41	90	112	3,5
C8	C8-131 -00098-25	80	25	63	41	50	98	3,4
	-00112-40	80	40	80	41	–	112	4,2

Spare Parts, Parts included in delivery

For size	Locking key	Locking screw
		-
C5...-25	8SMS795	P6SS16X20
C6...-25	8SMS795	P6SS16X20
C6...-40	8SMS795	P6SS16X20
C8...-25	8SMS795	P6SS16X20
C8...-40	10SMS795	P6SS20X20

Please check availability in current price and stock-list



• Holders, see page(s) 340

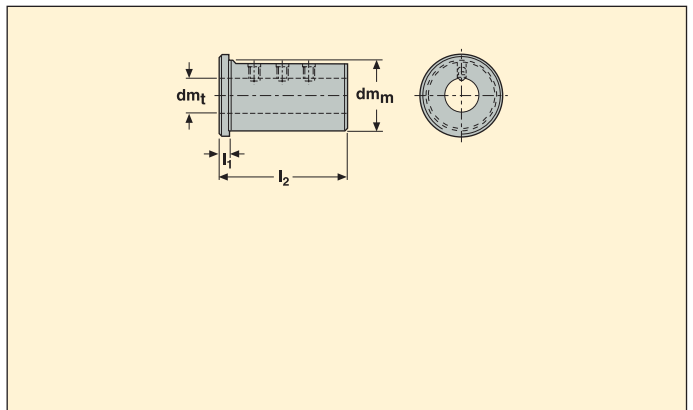

Part No.	Dimensions in mm				
	dm_m	dm_t	l_2	l_1	
132N- 2506	25	6	61	5	0,3
2508	25	8	61	5	0,3
2510	25	10	61	5	0,3
2512	25	12	61	5	0,3
2516	25	16	61	5	0,1
2520	25	20	61	5	0,1
132N- 4020	40	20	75	5	0,1
4025	40	25	75	5	0,5
4032	40	32	75	5	0,3

Spare Parts, Parts included in delivery

For size	Key	Screw
-2506	3SMS795	P6SS6X8
-2508	4SMS795	P6SS8X8
-2510	4SMS795	P6SS8X6
-2512	4SMS795	P6SS8X6
-4020	5SMS795	P6SS8X10
-4025	5SMS795	P6SS10X8
-2516/-2520/4032	-	-

Please check availability in current price and stock-list

Holder and sleeves for boring tools

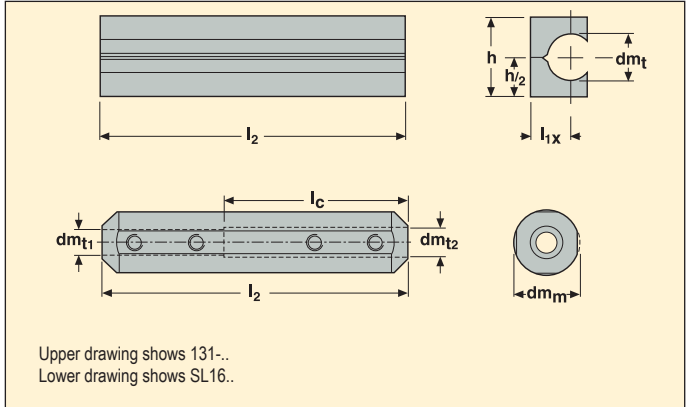

Part No.	Dimensions in mm								
	dm_m	dm_t	dm_{t1}	dm_{t2}	h	l_{1x}	l_2	l_{ct}	
131 -408	–	8	–	–	16	8	110	–	0,1
-410	–	10	–	–	18	9	110	–	0,1
-412	–	12	–	–	20	10	110	–	0,2
-416	–	16	–	–	24	12	110	–	0,2
-420	–	20	–	–	30	15	110	–	0,3
SL 160506	16	–	5	6	–	–	75	45	0,1
160608	16	–	6	8	–	–	75	45	0,1

Spare Parts, Parts included in delivery

Accessories, to be ordered separately

For size	Locking screw	Locking key
131- SL16..	– P6SS4X4	– 2SMS795

Please check availability in current price and stock-list

CCGT

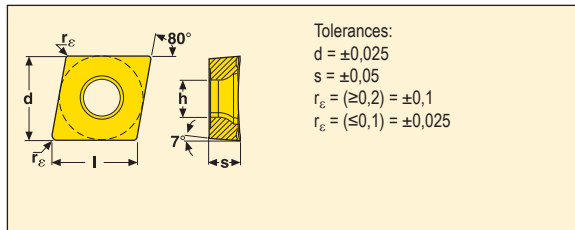

Size	Dimensions in mm				
	d	l	s	h	$r_e = \text{rep}$
0602	6,350	6,5	2,38	2,8	0,05-0,40
09T3	9,525	9,7	3,97	4,4	0,1-0,8
1204	12,700	12,9	4,76	5,5	0,4-0,8



Inserts	Part No.	Grades																							
		Coated														Uncoated		Cermets							
		TP0501	TP1501	TP2501	TP3500	TP200	TP40	TH1000	TH1500	TM2000	TM4000	TK1001	TK2001	TS2000	TS2500	CP200	CP500	CP600	HX	KX	883	890	TP1020	TP1030	
CCGT-AL	CCGT 060202F-AL																			■					
	060204F-AL																			■					
	CCGT 09T302F-AL																			■					
	09T304F-AL																			■					
	09T308F-AL																			■					
	CCGT 120404F-AL																			■					
120408F-AL																			■						
CCGT-F1	CCGT 0602005-F1																■								
	060201-F1																■								
	060204-F1																						■		
	CCGT 09T301-F1																■								■
	09T304-F1																■								■
CCGT-MF2	CCGT 060201-MF2																■								
	060204-MF2																■								
	CCGT 09T304-MF2																■								
CCGT-UX	CCGT 060204R-UX																■								
	060204L-UX																■								
	CCGT 09T304R-UX																■								
	09T304L-UX																■								
	CCGT 120408R-UX																■								
	120408L-UX																■								

■ Stock standard

Subject to change refer to current price- and stock-list

*Right-hand version shown

CCGX

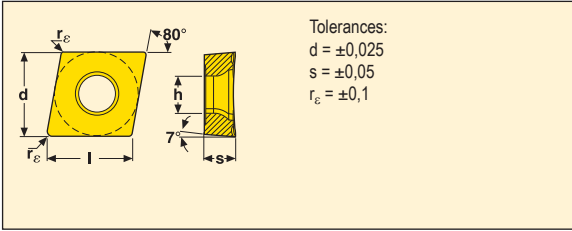

Size	Dimensions in mm				
	d	l	s	h	$r_e = \text{rep}$
0602	6,350	6,5	2,38	2,9	0,2
09T3	9,525	9,7	3,97	4,5	0,2

CCGX...W-F1



Inserts	Part No.	Grades																											
		Coated															Uncoated				Cermets								
		TP0501	TP1501	TP2501	TP3500	TP200	TP40	TH1000	TH1500	TM2000	TM4000	TK1001	TK2001	TS2000	TS2500	CP200	CP500	CP600	HX	KX	883	890	TP1020	TP1030					
CCGX...W-F1	CCGX_060202W-F1			■												■													
	CCGX_09T302W-F1			■												■													

■ Stock standard
 Subject to change refer to current price- and stock-list

CCMT

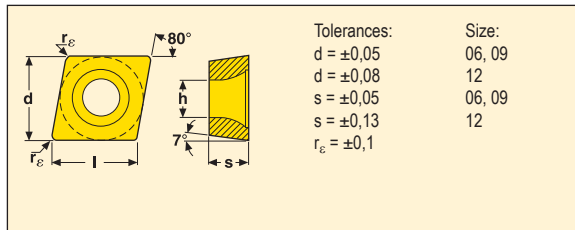

Size	Dimensions in mm				
	d	l	s	h	$r_e = \text{rep}$
0602	6,35	6,5	2,38	2,9	0,2-0,8
09T3	9,53	9,7	3,97	4,5	0,2-0,8
1204	12,70	12,9	4,76	5,6	0,4-1,2

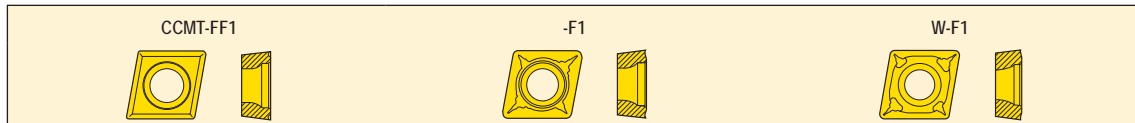

Inserts	Part No.	Grades																						
		Coated														Uncoated				Cermet				
		TP0501	TP1501	TP2501	TP3500	TP200	TP40	TH1000	TH1500	TM2000	TM4000	TK1001	TK2001	TS2000	TS2500	CP200	CP500	CP600	HX	KX	883	890	TP1020	TP1030
CCMT-FF1	CCMT 060202-FF1			■																				
	060204-FF1			■																				
	CCMT 09T304-FF1			■																				
CCMT-F1	CCMT 060202-F1		■	■	■		■				■		■		■	■							■	■
	060204-F1		■	■	■	■	■	■	■		■	■	■	■	■	■	■						■	■
	060208-F1			■	■		■				■					■								■
	CCMT 09T302-F1		■	■	■		■				■					■							■	■
	09T304-F1		■	■	■	■	■	■	■	■		■	■	■	■	■	■						■	■
	09T308-F1		■	■	■	■	■	■	■	■		■	■	■	■	■	■							■
	CCMT 120404-F1			■	■									■		■								
	120408-F1			■	■								■	■		■								
	120412-F1			■																				
CCMT...W-F1	CCMT 060204W-F1			■																			■	■
	CCMT 09T304W-F1		■	■																			■	■
	09T308W-F1		■	■																			■	■
	CCMT 120404W-F1			■																				
	120408W-F1			■																				

■ Stock standard

Subject to change refer to current price- and stock-list

CCMT

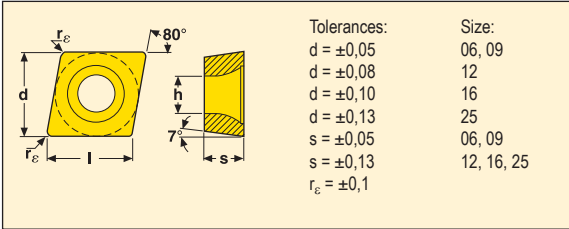

Size	Dimensions in mm				
	d	l	s	h	$r_E = rep$
0602	6,35	6,5	2,38	2,9	0,2-0,8
0903	9,53	9,7	3,18	4,5	0,4
09T3	9,53	9,7	3,97	4,5	0,2-1,2
1204	12,70	12,9	4,76	5,6	0,4-1,2
1605	15,88	16,1	5,56	5,6	0,8-1,2
2509	25,40	25,8	9,52	8,7	2,4

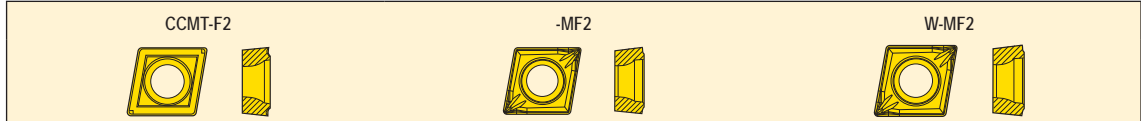

Inserts	Part No.	Grades																						
		Coated														Uncoated				Cermets				
		TP0501	TP1501	TP2501	TP3500	TP200	TP40	TH1000	TH1500	TM2000	TM4000	TK1001	TK2001	TS2000	TS2500	CP200	CP500	CP600	HX	KX	883	890	TP1020	TP1030
CCMT-F2	CCMT 060202-F2				■	■	■				■								■					
	060204-F2				■	■	■				■								■					
	060208-F2				■	■	■				■								■					
	CCMT 090304-F2																		■					
	CCMT 09T302-F2					■														■				
	09T304-F2				■	■	■				■			■		■				■				
	09T308-F2				■	■	■			■	■									■				
	09T312-F2																							
	CCMT 120404-F2					■	■													■				
	120408-F2				■	■	■			■	■									■				
	120412-F2				■																			
	CCMT 160508-F2						■				■													
160512-F2						■				■														
CCMT 250924T-F2							■																	
CCMT-MF2	CCMT 060202-MF2				■	■																	■	■
	060204-MF2	■	■	■	■					■								■	■				■	■
	060208-MF2	■	■	■	■																			
	CCMT 09T302-MF2				■	■																	■	
	09T304-MF2				■	■	■				■									■	■		■	■
	09T308-MF2	■	■	■	■					■										■				■
	CCMT 120408-MF2				■	■	■																	
CCMT...W-MF2	CCMT 060204W-MF2				■														■					
	CCMT 09T304W-MF2				■	■													■					
	09T308W-MF2				■	■				■									■					

■ Stock standard

Subject to change refer to current price- and stock-list

CCMT

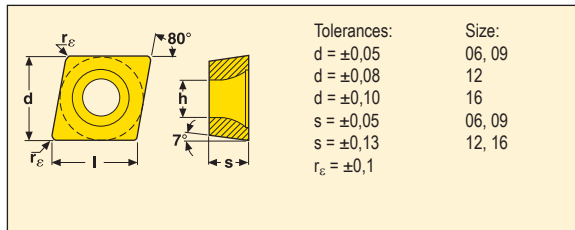

Size	Dimensions in mm				
	d	l	s	h	$r_e = \text{rep}$
0602	6,35	6,5	2,38	2,9	0,2-0,8
0903	9,53	9,7	3,18	4,5	0,4
09T3	9,53	9,7	3,97	4,5	0,2-1,2
1204	12,70	12,9	4,76	5,6	0,4-1,2
1605	15,88	16,1	5,56	5,6	0,8-1,6

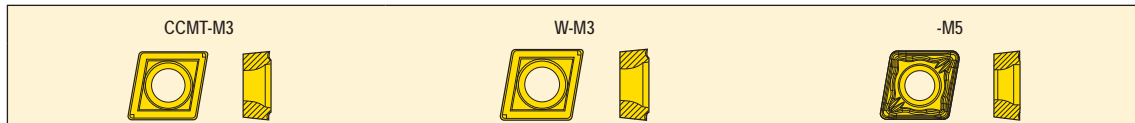

Inserts	Part No.	Grades																						
		Coated														Uncoated				Cermets				
		TP0501	TP1501	TP2501	TP3500	TP200	TP40	TH1000	TH1500	TM2000	TM4000	TK1001	TK2001	TS2000	TS2500	CP200	CP500	CP600	HX	KX	883	890	TP1020	TP1030
CCMT-M3	CCMT 060202-M3		■																					
	060204-M3		■	■							■	■												
	060208-M3			■								■												
	CCMT 090304-M3			■																				
	CCMT 09T302-M3		■	■																				
	09T304-M3		■	■																				
	09T308-M3		■	■								■	■											
	09T312-M3		■	■																				
	CCMT 120404-M3		■	■										■										
	120408-M3		■	■									■	■										
	120412-M3		■	■									■	■										
	CCMT 160508-M3			■										■										
160512-M3													■											
CCMT...W-M3	CCMT 09T308W-M3		■																					
CCMT-M5	CCMT 09T304-M5	■	■	■			■				■		■											
	09T308-M5	■	■	■	■		■				■	■	■											
	CCMT 120408-M5	■	■	■	■		■				■	■	■											
	120412-M5	■	■	■									■											
	CCMT 160512-M5			■																				
	160516-M5			■																				

■ Stock standard
 Subject to change refer to current price- and stock-list

CDCB

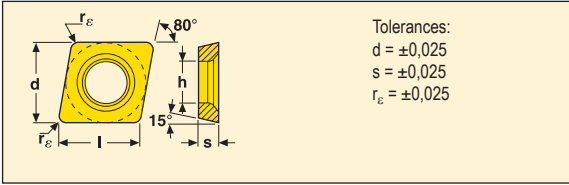

Size	Dimensions in mm				
	d	l	s	h	$r_e = \text{rep}$
04T0	3,969	4,030	0,966	2,04	0,05-0,4

CDCB



Inserts	Part No.	Grades																						
		Coated														Uncoated			Cermets					
		TP0501	TP1501	TP2501	TP3500	TP200	TP40	TH1000	TH1500	TM2000	TM4000	TK1001	TK2001	TS2000	TS2500	CP200	CP500	CP600	HX	KX	883	890	TP1020	TP1030
CDCB	CDCB 04T0005															■					■			
	04T002													■		■					■			
	04T004													■		■					■			

CNGG

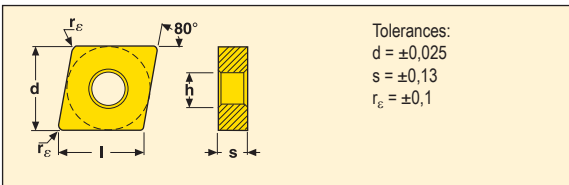

Size	Dimensions in mm				
	d	l	s	h	$r_e = \text{rep}$
1204	12,700	12,9	4,76	5,15	0,1-0,8

CNGG-MF1



-M1



Inserts	Part No.	Grades																						
		Coated														Uncoated			Cermets					
		TP0501	TP1501	TP2501	TP3500	TP200	TP40	TH1000	TH1500	TM2000	TM4000	TK1001	TK2001	TS2000	TS2500	CP200	CP500	CP600	HX	KX	883	890	TP1020	TP1030
CNGG-MF1	CNGG 120401-MF1													■		■						■		
	120402-MF1													■		■						■		
	120404-MF1													■		■						■		
	120408-MF1													■		■						■		
CNGG-M1	CNGG 120402-M1														■							■		
	120404-M1																					■		
	120408-M1																					■		

■ Stock standard

Subject to change refer to current price- and stock-list

Turning – Inserts

CNMA, CNMG

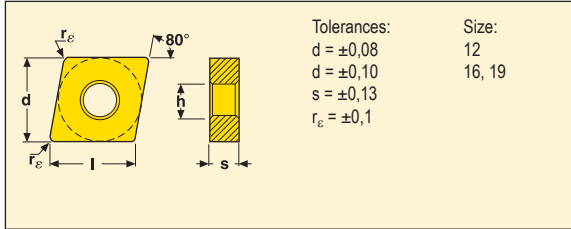

Size	Dimensions in mm				
	d	l	s	h	$r_e = \text{rep}$
1204	12,70	12,9	4,76	5,15	0,2-1,6
1606	15,88	16,1	6,35	6,35	0,8-1,6
1906	19,05	19,3	6,35	7,92	1,2-1,6

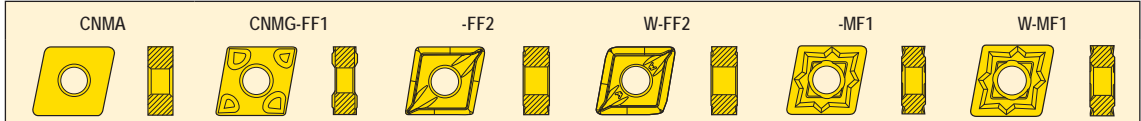

Inserts	Part No.	Grades																						
		Coated														Uncoated			Cermets					
		TP0501	TP1501	TP2501	TP3500	TP200	TP40	TH1000	TH1500	TM2000	TM4000	TK1001	TK2001	TS2000	TS2500	CP200	CP500	CP600	HX	KX	883	890	TP1020	TP1030
CNMA	CNMA 120404										■													
	120408										■	■												
	120412										■	■												
	120416											■												
	CNMA 160608											■	■											
	160612											■	■											
	160616											■	■											
	CNMA 190612												■	■										
190616												■	■											
CNMG-FF1	CNMG 120404-FF1			■																				
CNMG-FF2	CNMG 120402-FF2				■											■								■
	120404-FF2				■	■										■								■
	120408-FF2	■	■		■	■																		■
CNMG...W-FF2	CNMG 120404W-FF2				■																			■
	120408W-FF2		■	■																				■
CNMG-MF1	CNMG 120404-MF1							■		■	■			■		■	■					■		
	120408-MF1							■		■	■			■		■	■					■		
CNMG...W-MF1	CNMG 120404W-MF1																■							
	120408W-MF1																■							
	120412W-MF1																■							

■ Stock standard
 Subject to change refer to current price- and stock-list

CNMG

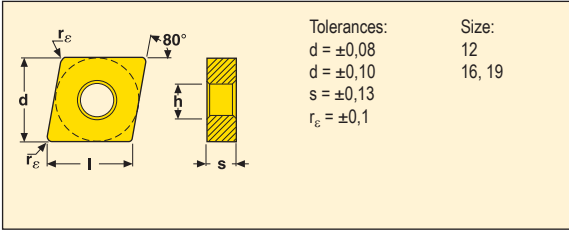

Size	Dimensions in mm				
	d	l	s	h	$r_e = rep$
1204	12,70	12,9	4,76	5,15	0,4-1,6
1606	15,88	16,1	6,35	6,35	0,8-1,2
1906	19,05	19,3	6,35	7,92	1,2

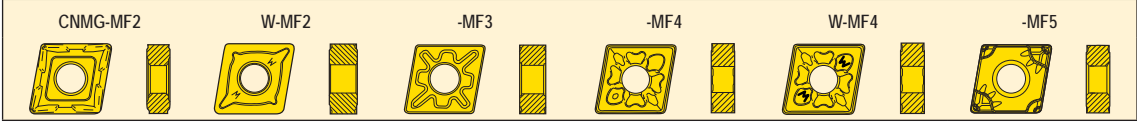

Inserts	Part No.	Grades																						
		Coated														Uncoated				Cermet				
		TP0501	TP1501	TP2501	TP3500	TP200	TP40	TH1000	TH1500	TM2000	TM4000	TK1001	TK2001	TS2000	TS2500	CP200	CP500	CP600	HX	KX	883	890	TP1020	TP1030
CNMG-MF2	CNMG 120404-MF2	■		■	■	■						■											■	■
	120408-MF2	■	■	■	■	■		■	■														■	■
	120412-MF2	■	■	■		■		■	■															
CNMG...W-MF2	CNMG 120404W-MF2		■	■																			■	
	120408W-MF2	■	■	■								■											■	
	120412W-MF2	■																						
CNMG-MF3	CNMG 120404-MF3				■				■															
	120408-MF3				■	■	■		■		■													
	120412-MF3				■		■																	
CNMG-MF4	CNMG 120404-MF4								■	■			■	■		■								
	120408-MF4			■	■				■	■			■	■		■								
	120412-MF4			■					■	■			■	■										
	120416-MF4								■	■														
	CNMG 160608-MF4								■	■														
	160612-MF4								■	■														
CNMG 190612-MF4								■	■															
CNMG...W-MF4	CNMG 120404W-MF4									■						■								
	120408W-MF4								■	■														
	120412W-MF4								■	■														
CNMG-MF5	CNMG 120408-MF5	■	■	■	■			■	■			■	■											
	120412-MF5	■	■	■	■			■	■			■	■											
	120416-MF5		■	■																				

■ Stock standard
 Subject to change refer to current price- and stock-list

CNMG

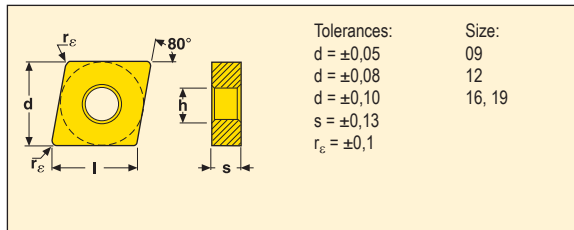

Size	Dimensions in mm				
	d	l	s	h	$r_e = \text{rep}$
0903	9,53	9,7	3,18	3,81	0,4-0,8
1204	12,70	12,9	4,76	5,15	0,4-1,6
1606	15,88	16,1	6,35	6,35	0,8-1,2
1906	19,05	19,3	6,35	7,92	0,8-1,6

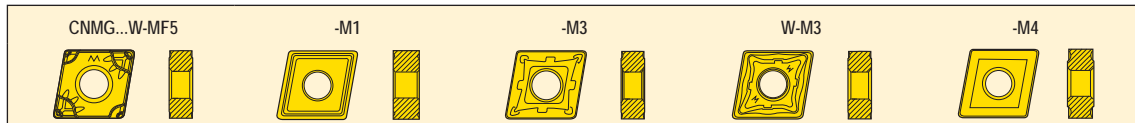

Inserts	Part No.	Grades																							
		Coated													Uncoated		Cermet								
		TP0501	TP1501	TP2501	TP3500	TP200	TP40	TH1000	TH1500	TM2000	TM4000	TK1001	TK2001	TS2000	TS2500	CP200	CP500	CP600	HX	KX	883	890	TP1020	TP1030	
CNMG...W-MF5	CNMG 120408W-MF5		■	■								■													
	CNMG 120404-M1												■												■
CNMG-M1	120408-M1														■										■
	120412-M1																								■
	CNMG 160608-M1																								■
	160612-M1																								■
	CNMG 190608-M1																								■
	190612-M1																								■
CNMG-M3	CNMG 090304-M3				■																				
	090308-M3				■																				
	CNMG 120404-M3				■	■	■	■	■																
	120408-M3	■	■	■	■	■	■		■			■													
	120412-M3	■	■	■	■	■	■																		
	120416-M3		■	■																					
	CNMG 160608-M3		■	■	■																				
	160612-M3	■	■	■	■																				
	CNMG 190608-M3		■	■	■																				
	190612-M3		■	■	■																				
190616-M3		■	■	■																					
CNMG...W-M3	CNMG 120408W-M3	■	■	■									■												
	120412W-M3	■	■	■									■												
CNMG-M4	CNMG 120408-M4											■	■												
	120412-M4											■	■												

■ Stock standard

Subject to change refer to current price- and stock-list

CNMG

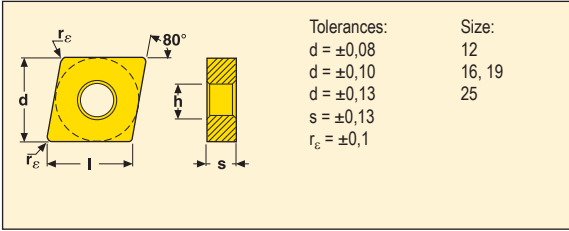

Size	Dimensions in mm				
	d	l	s	h	$r_e = \text{rep}$
1204	12,70	12,9	4,76	5,15	0,4-1,6
1606	15,88	16,1	6,35	6,35	0,8-2,4
1906	19,05	19,3	6,35	7,92	0,8-1,6

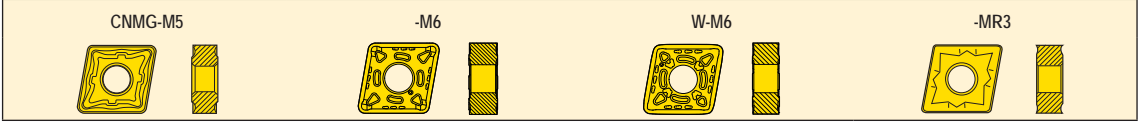

Inserts	Part No.	Grades																						
		Coated														Uncoated				Cermets				
		TP0501	TP1501	TP2501	TP3500	TP200	TP40	TH1000	TH1500	TM2000	TM4000	TK1001	TK2001	TS2000	TS2500	CP200	CP500	CP600	HX	KX	883	890	TP1020	TP1030
CNMG-M5	CNMG 120404-M5			■	■								■											
	120408-M5	■	■	■	■	■	■			■	■	■	■											
	120412-M5	■	■	■	■	■	■	■			■	■	■	■										
	120416-M5		■	■	■		■																	
	CNMG 160608-M5		■	■	■									■										
	160612-M5	■	■	■	■	■	■			■	■		■											
	160616-M5	■	■	■	■	■	■				■		■											
	CNMG 190608-M5		■	■	■		■																	
	190612-M5		■	■	■	■	■						■											
190616-M5		■	■	■	■	■				■		■												
CNMG-M6	CNMG 120408-M6	■	■	■	■								■											
	120412-M6	■	■	■	■								■											
	120416-M6		■	■																				
	CNMG 160612-M6	■	■	■	■								■											
	160616-M6	■	■	■									■											
	160624-M6		■	■																				
CNMG...W-M6	CNMG 120408W-M6			■																				
	120412W-M6		■	■																				
	CNMG 160612W-M6			■																				
	160616W-M6		■	■																				
CNMG-MR3	CNMG 120408-MR3												■		■	■						■		
	120412-MR3												■		■	■						■		

■ Stock standard
 Subject to change refer to current price- and stock-list

CNMG

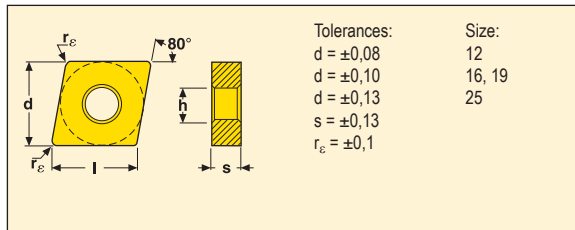

Size	Dimensions in mm				
	d	l	s	h	$r_e = \text{rep}$
1204	12,70	12,9	4,76	5,15	0,4-1,6
1206	12,70	12,9	6,35	5,15	1,2
1606	15,88	16,1	6,35	6,35	0,8-2,4
1906	19,05	19,3	6,35	7,92	0,8-2,4
2509	25,40	25,8	9,52	9,12	2,4

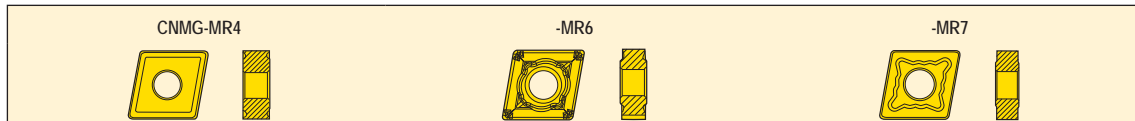

Inserts	Part No.	Grades																							
		Coated														Uncoated		Cermet							
		TP0501	TP1501	TP2501	TP3500	TP200	TP40	TH1000	TH1500	TM2000	TM4000	TK1001	TK2001	TS2000	TS2500	CP200	CP500	CP600	HX	KX	883	890	TP1020	TP1030	
CNMG-MR4	CNMG 120404-MR4																								
	120408-MR4														■						■				
	120412-MR4														■						■				
	120416-MR4														■						■				
	CNMG 160608-MR4														■							■			
	160612-MR4														■							■			
	CNMG 190612-MR4														■							■			
	190616-MR4														■							■			
CNMG 250924-MR4				■																					
CNMG-MR6	CNMG 120408-MR6		■	■	■																				
	120412-MR6		■	■	■																				
	120416-MR6				■																				
	CNMG 120612-MR6				■																				
	CNMG 160612-MR6				■																				
	160616-MR6				■																				
	CNMG 190612-MR6				■																				
CNMG-MR7	CNMG 120408-MR7		■	■	■		■				■	■	■												
	120412-MR7	■	■	■	■		■				■	■	■												
	120416-MR7		■	■	■		■					■	■												
	CNMG 160608-MR7				■																				
	160612-MR7	■	■	■	■		■				■	■	■												
	160616-MR7	■	■	■	■		■				■	■	■												
	160624-MR7		■										■												
	CNMG 190608-MR7				■		■																		
	190612-MR7	■	■	■	■	■	■				■	■	■												
	190616-MR7	■	■	■	■		■				■	■	■												
	190624-MR7		■	■																					
	CNMG 250924-MR7		■	■	■	■																			

■ Stock standard

Subject to change refer to current price- and stock-list

CNMM

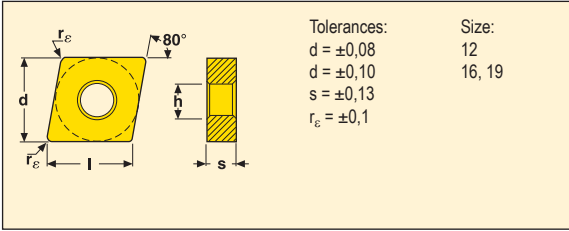

Size	Dimensions in mm				
	d	l	s	h	$r_e = \text{rep}$
1204	12,70	12,9	4,76	5,15	0,8-1,6
1606	15,88	16,1	6,35	6,35	1,2-1,6
1906	19,05	19,3	6,35	7,92	1,2-2,4

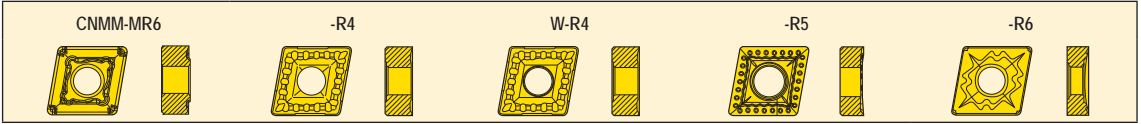

Inserts	Part No.	Grades																						
		Coated														Uncoated				Cermets				
		TP0501	TP1501	TP2501	TP3500	TP200	TP40	TH1000	TH1500	TM2000	TM4000	TK1001	TK2001	TS2000	TS2500	CP200	CP500	CP600	HX	KX	883	890	TP1020	TP1030
CNMM-MR6	CNMM 160612-MR6				■																			
	CNMM 190616-MR6		■																					
CNMM-R4	CNMM 120408-R4		■	■	■	■																		
	120412-R4	■	■	■	■	■	■																	
	120416-R4	■	■	■																				
	CNMM 160612-R4	■	■	■	■	■																		
	160616-R4	■	■	■	■																			
	CNMM 190612-R4	■	■	■	■																			
	190616-R4	■	■	■	■	■																		
	190624-R4	■	■	■	■																			
CNMM...W-R4	CNMM 120412W-R4		■	■																				
CNMM-R5	CNMM 160616-R5	■	■																					
	CNMM 190616-R5	■			■																			
	190624-R5	■																						
CNMM-R6	CNMM 120408-R6			■	■		■																	
	120412-R6				■																			
	CNMM 160612-R6				■		■																	
	CNMM 190612-R6				■		■																	
	190616-R6						■		■															

■ Stock standard

Subject to change refer to current price- and stock-list

CNMM

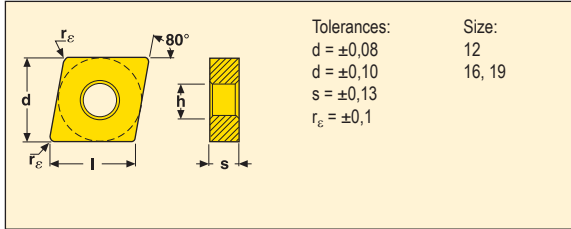

Size	Dimensions in mm				
	d	l	s	h	$r_e = \text{rep}$
1204	12,70	12,9	4,76	5,15	0,8-1,2
1606	15,88	16,1	6,35	6,35	1,2-2,4
1906	19,05	19,3	6,35	7,92	1,2-2,4

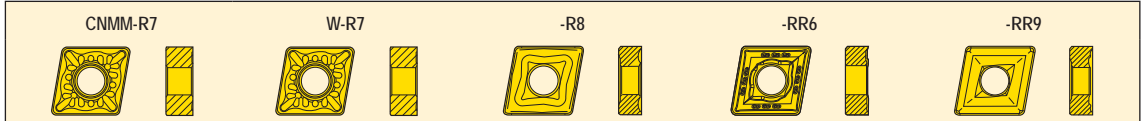

Inserts	Part No.	Grades																							
		Coated														Uncoated				Cermets					
		TP0501	TP1501	TP2501	TP3500	TP200	TP40	TH1000	TH1500	TM2000	TM4000	TK1001	TK2001	TS2000	TS2500	CP200	CP500	CP600	HX	KX	883	890	TP1020	TP1030	
CNMM-R7	CNMM 160612-R7				■																				
	160616-R7	■		■																					
	160624-R7	■																							
	CNMM 190612-R7			■	■																				
	190616-R7		■	■	■	■																			
	190624-R7	■		■	■																				
CNMM...W-R7	CNMM 190616W-R7		■	■																					
	190624W-R7	■	■	■																					
CNMM-R8	CNMM 120412-R8						■																		
	CNMM 190616-R8				■																				
CNMM-RR6	CNMM 120408-RR6				■																				
	120412-RR6				■																				
	CNMM 160612-RR6			■							■														
	160616-RR6		■	■							■														
	CNMM 190612-RR6			■							■														
	190616-RR6		■	■	■						■														
190624-RR6	■		■	■						■															
CNMM-RR9	CNMM 190616-RR9						■																		

■ Stock standard
 Subject to change refer to current price- and stock-list

DCGT

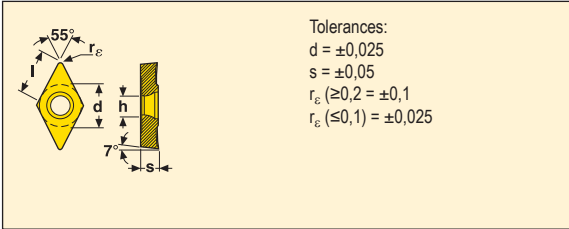

Size	Dimensions in mm				
	d	l	s	h	$r_e = \text{rep}$
0702	6,350	7,80	2,38	2,8	0,05-0,40
11T3	9,525	11,60	3,97	4,4	0,1-0,8

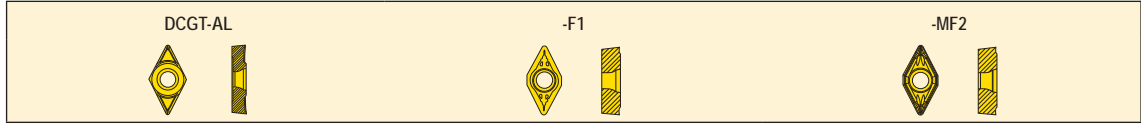

Inserts	Part No.	Grades																								
		Coated													Uncoated				Cermet							
		TP0501	TP1501	TP2501	TP3500	TP200	TP40	TH1000	TH1500	TM2000	TM4000	TK1001	TK2001	TS2000	TS2500	CP200	CP500	CP600	HX	KX	883	890	TP1020	TP1030		
DCGT-AL	DCGT 070202F-AL																			■						
	070204F-AL																			■						
	DCGT 11T302F-AL																			■						
	11T304F-AL																			■						
11T308F-AL																				■						
DCGT-F1	DCGT 0702005-F1																■									
	070201-F1																■									
	DCGT 11T301-F1																■									
	11T304-F1																							■		
DCGT-MF2	DCGT 11T304-MF2																■									

■ Stock standard
 Subject to change refer to current price- and stock-list

DCMT

Tolerances:
 $d = \pm 0,05$
 $d = \pm 0,08$
 $s = \pm 0,05$
 $s = \pm 0,13$
 $r_c = \pm 0,1$

Size:
 07, 11
 15
 07, 11
 15

Size	Dimensions in mm				
	d	l	s	h	$r_c = \text{rep}$
0702	6,35	7,8	2,38	2,9	0,2-0,8
11T3	9,53	11,6	3,97	4,5	0,2-1,2
1504	12,70	15,5	4,76	5,6	0,4-1,2



Inserts	Part No.	Grades																						
		Coated														Uncoated		Cermet						
		TP0501	TP1501	TP2501	TP3500	TP200	TP40	TH1000	TH1500	TM2000	TM4000	TK1001	TK2001	TS2000	TS2500	CP200	CP500	CP600	HX	KX	883	890	TP1020	TP1030
DCMT-FF1	DCMT 11T302-FF1			■																				
	11T304-FF1			■																				
	11T308-FF1			■																				
DCMT-F1	DCMT 070202-F1			■	■								■		■	■								
	070204-F1		■	■	■		■			■	■		■		■	■								■
	070208-F1		■		■											■								■
	DCMT 11T302-F1			■	■											■								■
	11T304-F1	■	■	■	■	■		■	■	■	■	■	■	■		■	■	■					■	■
	11T308-F1	■	■	■	■	■				■	■	■	■	■		■	■						■	■
11T312-F1		■	■																				■	
DCMT-F2	DCMT 070202-F2										■								■					
	070204-F2				■	■	■			■	■								■					
	070208-F2				■		■			■	■								■					
	DCMT 11T302-F2				■	■	■												■					
	11T304-F2				■	■	■			■	■			■		■			■					■
	11T308-F2				■	■	■			■	■								■					■
	DCMT 150404-F2				■	■	■												■					
	150408-F2				■	■	■												■					
	150412-F2				■														■					
DCMT-MF2	DCMT 070202-MF2																■						■	
	070204-MF2		■	■	■											■	■						■	
	070208-MF2				■																			
	DCMT 11T302-MF2		■	■													■	■					■	■
	11T304-MF2	■	■	■	■						■					■	■						■	■
	11T308-MF2	■	■	■	■						■					■	■						■	■
	11T312-MF2			■																				

■ Stock standard

Subject to change refer to current price- and stock-list

DCMT

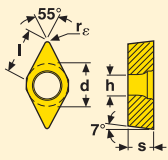

Tolerances:
 $d = \pm 0,05$
 $s = \pm 0,05$
 $r_e = \pm 0,1$

Size	Dimensions in mm				
	d	l	s	h	$r_e = \text{rep}$
0702	6,35	7,8	2,38	2,9	0,2-0,8
11T3	9,53	11,6	3,97	4,5	0,2-1,2
1504	12,70	15,5	4,76	5,6	0,4-1,2

DCMT-M3



-M5



Inserts	Part No.	Grades																								
		Coated															Uncoated				Cermets					
		TP0501	TP1501	TP2501	TP3500	TP200	TP40	TH1000	TH1500	TM2000	TM4000	TK1001	TK2001	TS2000	TS2500	CP200	CP500	CP600	HX	KX	883	890	TP1020	TP1030		
DCMT-M3	DCMT 070202-M3		■	■																						
	070204-M3		■	■																						
	070208-M3		■	■																						
	DCMT 11T302-M3		■	■																						
	11T304-M3	■	■	■								■														
	11T308-M3		■	■								■														
	DCMT 150404-M3		■	■																						
	150408-M3		■	■																						
	150412-M3		■	■																						
DCMT-M5	DCMT 11T308-M5	■	■	■	■		■				■															
	11T312-M5			■																						

■ Stock standard
 Subject to change refer to current price- and stock-list

DCMX

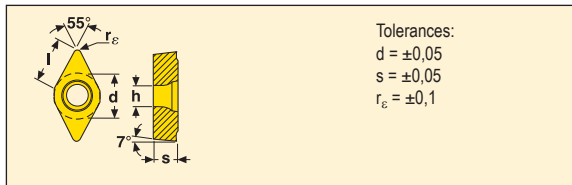

Size	Dimensions in mm				
	d	l	s	h	$r_e = \text{rep}$
11T3	9,53	11,6	3,97	4,5	0,4-0,8

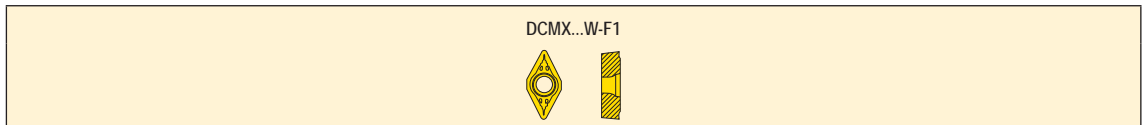

Inserts	Part No.	Grades																							
		Coated												Uncoated		Cermet									
		TP0501	TP1501	TP2501	TP3500	TP200	TP40	TH1000	TH1500	TM2000	TM4000	TK1001	TK2001	TS2000	TS2500	CP200	CP500	CP600	HX	KX	883	890	TP1020	TP1030	
DCMX...W-F1	DCMX 11T304W-F1		■	■																				■	■
	11T308W-F1		■	■																				■	

DNGG, DNGM

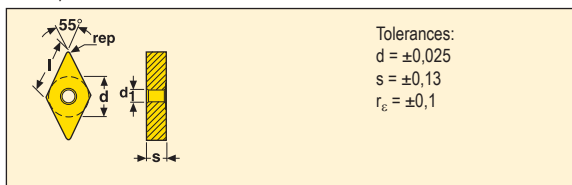

Size	Dimensions in mm				
	d	l	s	h	$r_e = \text{rep}$
1504	12,700	15,5	4,76	5,15	0,2-0,8
1506	12,700	15,5	6,35	5,15	0,8

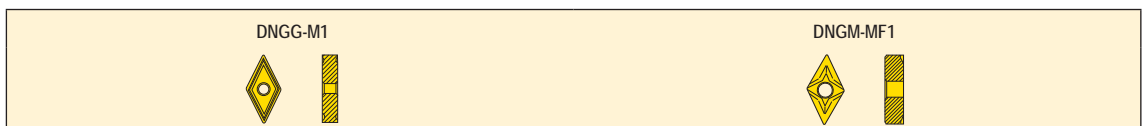

Inserts	Part No.	Grades																							
		Coated												Uncoated		Cermet									
		TP0501	TP1501	TP2501	TP3500	TP200	TP40	TH1000	TH1500	TM2000	TM4000	TK1001	TK2001	TS2000	TS2500	CP200	CP500	CP600	HX	KX	883	890	TP1020	TP1030	
DNGG-M1	DNGG 150402-M1																				■				
	150404-M1																				■				
	150408-M1												■								■				
DNGM-MF1	DNGM 150408-MF1												■		■										
	DNGM 150608-MF1												■			■									

■ Stock standard
 Subject to change refer to current price- and stock-list

DNMA, DNMG

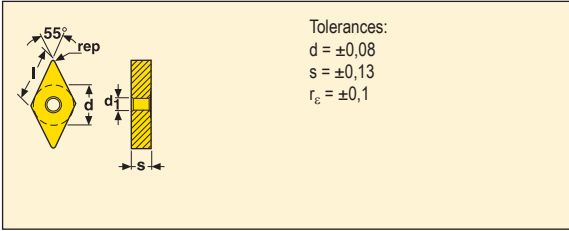

Size	Dimensions in mm				
	d	l	s	h	$r_e = rep$
1504	12,70	15,5	4,76	5,15	0,4-1,2
1506	12,70	15,5	6,35	5,15	0,4-1,6

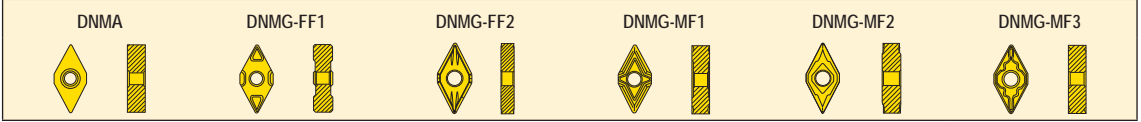

Inserts	Part No.	Grades																							
		Coated														Uncoated				Cermet					
		TP0501	TP1501	TP2501	TP3500	TP200	TP40	TH1000	TH1500	TM2000	TM4000	TK1001	TK2001	TS2000	TS2500	CP200	CP500	CP600	HX	KX	883	890	TP1020	TP1030	
DNMA	DNMA 150408											■	■												
	DNMA 150608											■	■												
	150612											■													
	150616											■													
DNMG-FF1	DNMG 150604-FF1																							■	
DNMG-FF2	DNMG 150404-FF2		■	■																				■	
	150408-FF2	■	■	■																				■	
	DNMG 150604-FF2		■	■	■											■								■	
	150608-FF2	■	■	■	■																				■
DNMG-MF1	DNMG 150404-MF1							■						■		■							■		
	150408-MF1							■					■		■								■		
	DNMG 150604-MF1							■		■	■			■		■	■						■		
	150608-MF1							■		■	■			■		■	■						■		
DNMG-MF2	DNMG 150404-MF2	■	■	■	■																				
	150408-MF2	■	■	■	■			■					■												
	150412-MF2			■																					
	DNMG 150604-MF2		■	■	■	■																		■	■
	150608-MF2	■	■	■	■	■		■	■														■	■	
	150612-MF2	■	■	■		■		■	■				■												
DNMG-MF3	DNMG 150404-MF3				■																				
	150408-MF3				■	■																			
	DNMG 150604-MF3				■																				
	150608-MF3				■								■												

■ Stock standard
 Subject to change refer to current price- and stock-list

DNMG

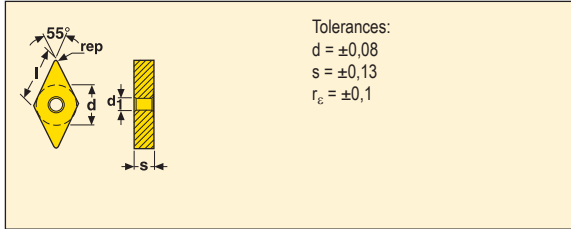

Size	Dimensions in mm				
	d	l	s	h	$r_e = rep$
1504	12,70	15,5	4,76	5,15	0,4-1,6
1506	12,70	15,5	6,35	5,15	0,4-1,6

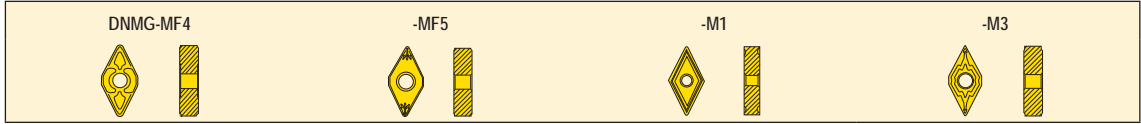

Inserts	Part No.	Grades																						
		Coated																Uncoated			Cermets			
		TP0501	TP1501	TP2501	TP3500	TP200	TP40	TH1000	TH1500	TM2000	TM4000	TK1001	TK2001	TS2000	TS2500	CP200	CP500	CP600	HX	KX	883	890	TP1020	TP1030
DNMG-MF4	DNMG 150404-MF4									■														
	150408-MF4								■	■				■	■									
	150412-MF4													■	■									
	DNMG 150604-MF4									■	■													
	150608-MF4			■						■	■				■	■								
	150612-MF4									■	■				■	■								
DNMG-MF5	DNMG 150408-MF5		■	■				■	■					■	■									
	150412-MF5		■	■										■	■									
	150416-MF5																							
	DNMG 150608-MF5	■	■	■				■	■			■		■	■									
	150612-MF5	■	■	■				■	■					■	■									
150616-MF5			■																					
DNMG-M1	DNMG 150404-M1																						■	
	150408-M1																						■	
	150412-M1																						■	
DNMG-M3	DNMG 150404-M3		■	■	■									■										
	150408-M3	■	■	■	■									■										
	150412-M3	■	■	■	■									■										
	DNMG 150604-M3		■	■	■	■								■										
	150608-M3	■	■	■	■	■								■										
	150612-M3	■	■	■	■	■								■										
	150616-M3		■	■																				

■ Stock standard
 Subject to change refer to current price- and stock-list

DNMG

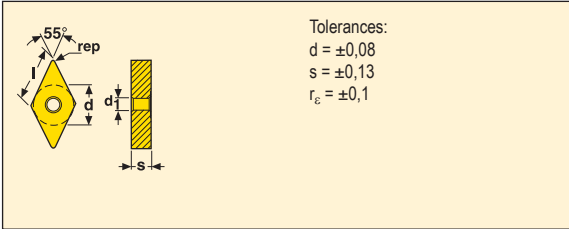

Size	Dimensions in mm				
	d	l	s	h	$r_e = rep$
1504	12,70	15,5	4,76	5,15	0,4-1,6
1506	12,70	15,5	6,35	5,15	0,4-1,6

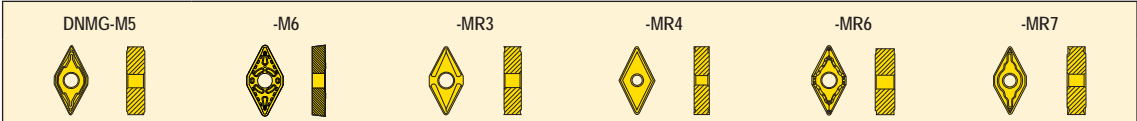

Inserts	Part No.	Grades																							
		Coated														Uncoated				Cermet					
		TP0501	TP1501	TP2501	TP3500	TP200	TP40	TH1000	TH1500	TM2000	TM4000	TK1001	TK2001	TS2000	TS2500	CP200	CP500	CP600	HX	KX	883	890	TP1020	TP1030	
DNMG-M5	DNMG 150404-M5				■																				
	150408-M5	■	■	■					■			■													
	150412-M5		■	■	■					■															
	DNMG 150604-M5			■	■																				
	150608-M5	■	■	■	■	■				■	■	■	■												
	150612-M5	■	■	■	■	■				■		■	■												
150616-M5	■	■	■	■																					
DNMG-M6	DNMG 150408-M6		■	■																					
	150412-M6		■	■	■																				
	150416-M6			■																					
	DNMG 150608-M6		■	■								■													
	150612-M6	■	■	■	■							■													
	150616-M6		■	■																					
DNMG-MR3	DNMG 150408-MR3													■		■	■						■		
	150412-MR3													■		■									
	DNMG 150608-MR3													■		■	■						■		
	150612-MR3																■						■		
DNMG-MR4	DNMG 150408-MR4														■								■		
	150412-MR4																						■		
DNMG-MR6	DNMG 150608-MR6				■																				
	150616-MR6																								
DNMG-MR7	DNMG 150608-MR7		■																						
	150612-MR7	■	■		■								■												

■ Stock standard

Subject to change refer to current price- and stock-list

DNMU

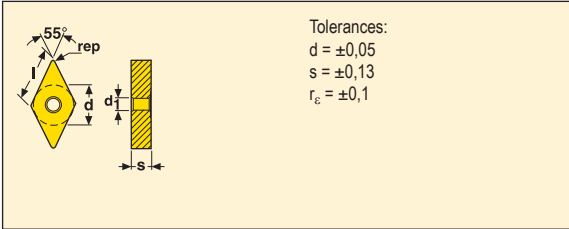

Size	Dimensions in mm				
	d	l	s	h	$r_e = rep$
1104	9,53	11,6	4,76	3,81	0,2-1,2



Inserts	Part No.	Grades																						
		Coated														Uncoated				Cermet				
		TP0501	TP1501	TP2501	TP3500	TP200	TP40	TH1000	TH1500	TM2000	TM4000	TK1001	TK2001	TS2000	TS2500	CP200	CP500	CP600	HX	KX	883	890	TP1020	TP1030
DNMU-FF2	DNMU 110404-FF2			■													■							■
	110408-FF2	■	■	■	■												■							■
DNMU-MF1	DNMU 110404-MF1								■	■							■							
	110408-MF1								■	■														
DNMU-MF2	DNMU 110404-MF2	■	■	■	■	■					■													■
	110408-MF2	■	■	■	■	■						■												■
	110412-MF2			■					■															■
DNMU-MF4	DNMU 110404-MF4								■	■														
	110408-MF4								■	■														
DNMU-MF5	DNMU 110404-MF5			■																				
	110408-MF5			■																				
	110412-MF5			■																				
DNMU-M3	DNMU 110402-M3		■	■																				
	110404-M3		■	■	■	■		■	■				■											
	110408-M3	■	■	■	■	■		■	■				■											
	110412-M3	■	■										■											
DNMU-M5	DNMU 110408-M5		■												■									
	110412-M5		■												■									

■ Stock standard

Subject to change refer to current price- and stock-list

LNMX

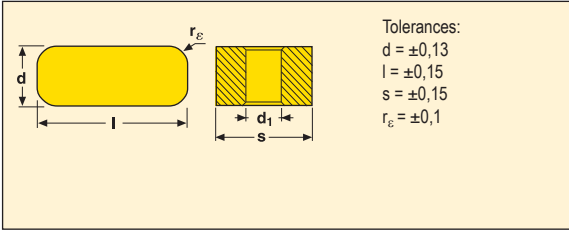

Size	Dimensions in mm				
	d	l	s	d ₁	r _e = rep
1919	10,00	19,05	19,05	6,35	4,0
3019	12,00	30,00	19,05	6,35	4,0

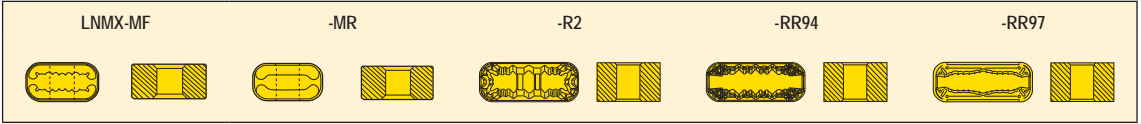

Inserts	Part No.	Grades																									
		Coated																Uncoated				Cermets					
		TP0501	TP1501	TP2501	TP3500	TP200	TP40	TH1000	TH1500	TM2000	TM4000	TK1001	TK2001	TS2000	TS2500	CP200	CP500	CP600	HX	KX	883	890	TP1020	TP1030			
LNMX-MF	LNMX 191940-MF		■	■									■														
	LNMX 301940-MF		■	■									■														
LNMX-MR	LNMX 191940-MR		■	■									■														
	LNMX 301940-MR		■	■																							
LNMX-R2	LNMX 191940-R2	■	■			■																					
	LNMX 301940-R2	■	■			■																					
LNMX-RR94	LNMX 191940-RR94	■	■			■																					
	LNMX 301940-RR94	■	■			■																					
LNMX-RR97	LNMX 301940-RR97	■	■			■																					

■ Stock standard
 Subject to change refer to current price- and stock-list

RCGS

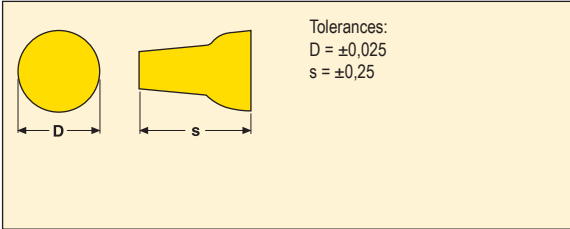

Size	Dimensions in mm	
	D	s
4.76	4,760	6,35
6.35	6,350	9,13
9.52	9,525	13,10
12.7	12,700	16,67



Inserts	Part No.	Grades																						
		Coated														Uncoated				Cermets				
		TP0501	TP1501	TP2501	TP3500	TP200	TP40	TH1000	TH1500	TM2000	TM4000	TK1001	TK2001	TS2000	TS2500	CP200	CP500	CP600	HX	KX	883	890	TP1020	TP1030
RCGS-46	RCGS 4.76-46													■	■	■					■	■		
	RCGS 6.35-46													■	■	■					■	■		
	RCGS 9.525-46													■	■	■					■	■		
	RCGS 12.7-46													■	■	■					■	■		
RCGS-PS	RCGS 4.76-PS													■		■					■			
	RCGS 6.35-PS													■		■					■	■		
	RCGS 9.525-PS													■		■					■	■		
	RCGS 12.7-PS																				■			

■ Stock standard

Subject to change refer to current price- and stock-list

RCMT

Tolerances:
 $D = \pm 0,05$
 $D = \pm 0,08$
 $D = \pm 0,10$
 $s = \pm 0,05$
 $s = \pm 0,13$

Size:
 06, 08, 10
 12
 16
 06, 08, 10
 12, 16

Size	Dimensions in mm		
	D	s	h
0602	6,00	2,38	2,9
0803	8,00	3,18	3,5
10T3	10,00	3,97	4,5
1204	12,00	4,76	4,5
1606	16,00	6,35	5,6

RCMT-F1

-F2

-M3

Inserts	Part No.	Grades																						
		Coated														Uncoated		Cermet						
		TP0501	TP1501	TP2501	TP3500	TP200	TP40	TH1000	TH1500	TM2000	TM4000	TK1001	TK2001	TS2000	TS2500	CP200	CP500	CP600	HX	KX	883	890	TP1020	TP1030
RCMT-F1	RCMT 0602M0-F1			■													■							
	RCMT 0803M0-F1			■													■							
	RCMT 10T3M0-F1			■	■												■							
	RCMT 1204M0-F1		■	■	■								■				■							
	RCMT 1606M0-F1	■	■	■																				
RCMT-F2	RCMT 0602M0-F2						■						■					■						
	RCMT 0803M0-F2				■	■							■		■			■						
	RCMT 10T3M0-F2				■	■	■						■					■						
	RCMT 1204M0-F2				■	■	■						■					■						
	RCMT 1606M0-F2				■		■											■						
RCMT-M3	RCMT 0602M0-M3			■																				
	RCMT 0803M0-M3		■	■									■											
	RCMT 10T3M0-M3		■	■									■											
	RCMT 1204M0-M3		■	■									■	■										
	RCMT 1606M0-M3	■	■	■																				

■ Stock standard

Subject to change refer to current price- and stock-list

RCMX

Tolerances:
 D = ±0,08
 D = ±0,10
 s = ±0,05
 s = ±0,13

Size:
 10, 12, 16, 20
 25, 32

Size	Dimensions in mm		
	D	s	h
1003	10,00	3,18	3,6
1204	12,00	4,76	4,2
1606	16,00	6,35	5,2
2006	20,00	6,35	6,5
2507	25,00	7,94	7,2
3209	32,00	9,52	9,5

Inserts	Part No.	Grades																						
		Coated														Uncoated				Cermet				
		TP0501	TP1501	TP2501	TP3500	TP200	TP40	TH1000	TH1500	TM2000	TM4000	TK1001	TK2001	TS2000	TS2500	CP200	CP500	CP600	HX	KX	883	890	TP1020	TP1030
RCMX	RCMX 100300				■																			
	RCMX 120400				■																			
	RCMX 200600				■	■						■												
	RCMX 250700				■	■						■	■											
	RCMX 320900				■	■							■											
RCMX-R2	RCMX 200600-R2	■		■																				
	RCMX 250700-R2	■		■																				
	RCMX 320900-R2	■		■																				
RCMX-RR94	RCMX 120400-RR94			■																				
	RCMX 160600-RR94		■	■																				
	RCMX 200600-RR94	■	■	■																				
	RCMX 250700-RR94	■	■	■																				
	RCMX 320900-RR94	■	■	■																				
RCMX-RR97	RCMX 200600-RR97	■		■																				
	RCMX 250700-RR97	■		■																				
	RCMX 320900-RR97	■		■																				

■ Stock standard
 Subject to change refer to current price- and stock-list

SCMT

Tolerances:
 $l = \pm 0,05$
 $l = \pm 0,08$
 $l = \pm 0,13$
 $s = \pm 0,05$
 $s = \pm 0,13$
 $r_e = \pm 0,1$

Size:
 06, 07, 09
 12
 15, 25
 06, 07, 09
 12, 15, 25

Size	Dimensions in mm			
	l	s	h	$r_e = \text{rep}$
0602	6,35	2,38	2,9	0,4
0703	7,94	3,18	3,5	0,8
09T3	9,52	3,97	4,5	0,4-1,2
1204	12,70	4,76	5,6	0,8-1,2
1505	15,88	5,56	8,7	1,2
2509	25,40	9,52	8,7	2,4

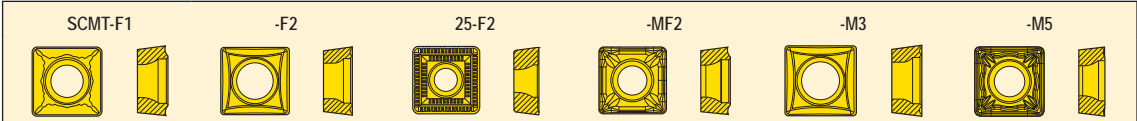

Inserts	Part No.	Grades																							
		Coated														Uncoated				Cermet					
		TP0501	TP1501	TP2501	TP3500	TP200	TP40	TH1000	TH1500	TM2000	TM4000	TK1001	TK2001	TS2000	TS2500	CP200	CP500	CP600	HX	KX	883	890	TP1020	TP1030	
SCMT-F1	SCMT 09T304-F1			■	■											■									
	09T308-F1			■	■	■						■				■									■
	09T312-F1				■																				
	SCMT 120408-F1			■	■												■								
	120412-F1		■				■										■								
SCMT-F2	SCMT 060204-F2						■	■																	
	SCMT 070308-F2				■			■																	
	SCMT 09T304-F2				■			■		■	■														
	09T308-F2				■	■	■			■	■														
	SCMT 120408-F2				■	■	■			■	■														
	SCMT 150512-F2								■																
SCMT 250924T-F2									■																
SCMT-MF2	SCMT 09T304-MF2			■																					
	09T308-MF2			■	■											■									■
	09T312-MF2				■																				
	SCMT 120408-MF2			■	■																				
SCMT-M3	SCMT 060204-M3			■																					
	SCMT 070308-M3			■																					
	SCMT 09T304-M3				■																				
	09T308-M3		■	■								■	■												
	SCMT 120408-M3		■	■								■	■												
120412-M3												■													
SCMT-M5	SCMT 120408-M5	■		■	■		■					■													

■ Stock standard
 Subject to change refer to current price- and stock-list

SNMA, SNMG

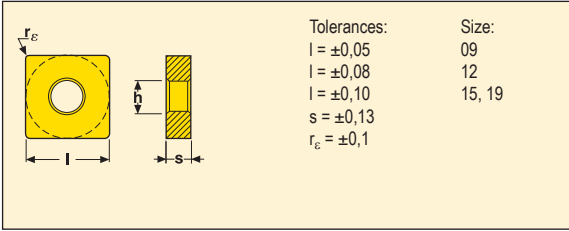

Size	Dimensions in mm			
	l	s	h	$r_e = \text{rep}$
0903	9,53	3,18	3,81	0,4-0,8
1204	12,70	4,76	5,15	0,8-1,6
1506	15,88	6,35	6,35	1,2
1906	19,05	6,35	7,92	1,2-1,6

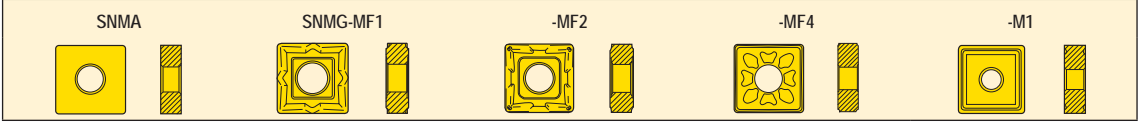

Inserts	Part No.	Grades																							
		Coated														Uncoated				Cermet					
		TP0501	TP1501	TP2501	TP3500	TP200	TP40	TH1000	TH1500	TM2000	TM4000	TK1001	TK2001	TS2000	TS2500	CP200	CP500	CP600	HX	KX	883	890	TP1020	TP1030	
SNMA	SNMA 090308											■													
	SNMA 120408											■	■												
	120412											■													
	120416											■													
	SNMA 150612											■	■												
	SNMA 190612												■												
	190616												■	■											
SNMG-MF1	SNMG 120408-MF1								■	■			■		■	■						■			
	120412-MF1												■		■	■						■			
SNMG-MF2	SNMG 090304-MF2			■																					
	090308-MF2			■																					
	SNMG 120408-MF2	■	■	■	■	■																	■		
	120412-MF2	■	■																				■		
SNMG-MF4	SNMG 120408-MF4								■	■															
	120412-MF4								■	■															
SNMG-M1	SNMG 120408-M1																					■			
	SNMG 150612-M1																					■			
	SNMG 190616-M1																					■			

■ Stock standard

Subject to change refer to current price- and stock-list

SNMG

Tolerances:
 $l = \pm 0,05$
 $l = \pm 0,08$
 $l = \pm 0,10$
 $s = \pm 0,13$
 $r_e = \pm 0,1$

Size:
 09
 12
 15, 19

Size	Dimensions in mm			
	l	s	h	$r_e = \text{rep}$
0903	9,53	3,18	3,81	0,8
1204	12,70	4,76	5,15	0,4-1,6
1506	15,88	6,35	6,35	0,8-1,6
1906	19,05	6,35	7,92	1,2-1,6



Inserts	Part No.	Grades																						
		Coated																Uncoated				Cermets		
		TP0501	TP1501	TP2501	TP3500	TP200	TP40	TH1000	TH1500	TM2000	TM4000	TK1001	TK2001	TS2000	TS2500	CP200	CP500	CP600	HX	KX	883	890	TP1020	TP1030
SNMG-M3	SNMG 120404-M3			■	■																			
	120408-M3		■	■	■	■	■					■												
	120412-M3		■	■	■	■	■																	
	120416-M3		■	■																				
	SNMG 150612-M3		■	■																				
	SNMG 190612-M3			■	■																			
190616-M3			■																					
SNMG-M5	SNMG 090308-M5			■	■																			
	SNMG 120408-M5		■	■	■	■	■			■	■	■	■											
	120412-M5		■	■	■	■	■			■	■		■											
	120416-M5		■	■	■																			
	SNMG 150608-M5			■																				
	150612-M5		■	■	■		■				■													
	150616-M5	■	■	■	■		■																	
	SNMG 190612-M5			■	■		■				■	■		■										
190616-M5	■	■	■	■		■				■	■													
SNMG-M6	SNMG 120408-M6		■	■																				
	120412-M6		■	■																				
	SNMG 150612-M6		■	■																				
	150616-M6	■	■	■																				
SNMG-MR3	SNMG 120408-MR3												■		■	■						■		
	120412-MR3												■		■	■								
	SNMG 190616-MR3														■	■						■		

■ Stock standard

Subject to change refer to current price- and stock-list

SNMG, SNMM

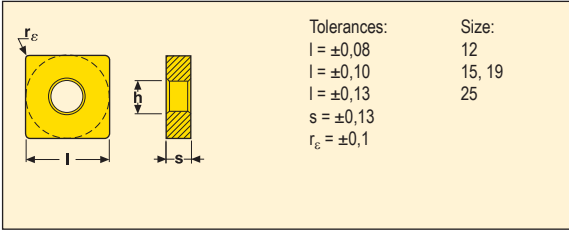

Size	Dimensions in mm			
	l	s	h	$r_e = \text{rep}$
1204	12,70	4,76	5,15	0,8-1,6
1206	12,70	6,35	5,15	1,2
1506	15,88	6,35	6,35	1,2-2,4
1906	19,05	6,35	7,92	1,2-2,4
2509	25,40	9,52	9,12	2,4

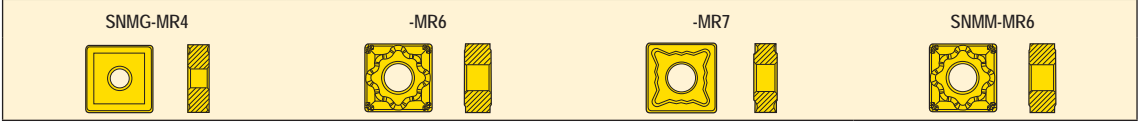

Inserts	Part No.	Grades																							
		Coated														Uncoated			Cermet						
		TP0501	TP1501	TP2501	TP3500	TP200	TP40	TH1000	TH1500	TM2000	TM4000	TK1001	TK2001	TS2000	TS2500	CP200	CP500	CP600	HX	KX	883	890	TP1020	TP1030	
SNMG-MR4	SNMG 120408-MR4																								
	120412-MR4																								
	120416-MR4																								
	SNMG 150612-MR4																								
	SNMG 190612-MR4																								
	190616-MR4																								
	SNMG 250924-MR4																								
SNMG-MR6	SNMG 120612-MR6																								
	SNMG 150612-MR6																								
SNMG-MR7	SNMG 120408-MR7																								
	120412-MR7																								
	120416-MR7																								
	SNMG 150612-MR7																								
	150616-MR7																								
	SNMG 190612-MR7																								
	190616-MR7																								
	190624-MR7																								
	SNMG 250924-MR7																								
	SNMM-MR6	SNMM 150624-MR6																							

■ Stock standard
 Subject to change refer to current price- and stock-list

SNMM

Tolerances:
 $l = \pm 0,08$
 $l = \pm 0,10$
 $l = \pm 0,13$
 $s = \pm 0,13$
 $r_e = \pm 0,1$

Size:
 12
 15, 19
 25

Size	Dimensions in mm			
	l	s	h	$r_e = \text{rep}$
1204	12,70	4,76	5,15	0,8-1,2
1506	15,88	6,35	6,35	1,2-2,4
1906	19,05	6,35	7,92	1,2-2,4
2507	25,40	7,94	9,12	2,4
2509	25,40	9,52	9,12	2,4



Inserts	Part No.	Grades																						
		Coated														Uncoated		Cermet						
		TP0501	TP1501	TP2501	TP3500	TP200	TP40	TH1000	TH1500	TM2000	TM4000	TK1001	TK2001	TS2000	TS2500	CP200	CP500	CP600	HX	KX	883	890	TP1020	TP1030
SNMM-R4	SNMM 120408-R4				■																			
	120412-R4			■	■																			
	SNMM 150612-R4			■	■																			
	150616-R4	■		■																				
	SNMM 190612-R4			■	■																			
	190616-R4	■	■	■	■	■	■																	
190624-R4	■		■	■																				
SNMM-R5	SNMM 190616-R5			■																				
	190624-R5			■																				
SNMM-R6	SNMM 120408-R6																							
	SNMM 190612-R6				■																			
	190616-R6				■																			
SNMM-R7	SNMM 150624-R7			■																				
	SNMM 190612-R7			■																				
	190616-R7			■	■	■																		
	190624-R7	■		■	■	■																		
	SNMM 250724-R7	■		■	■	■																		
	SNMM 250924-R7	■		■	■	■																		
SNMM...W-R7	SNMM 190616W-R7			■																				
	190624W-R7			■																				
SNMM-R8	SNMM 120412-R8																							
	SNMM 190616-R8				■																			

■ Stock standard

Subject to change refer to current price- and stock-list

SNMM

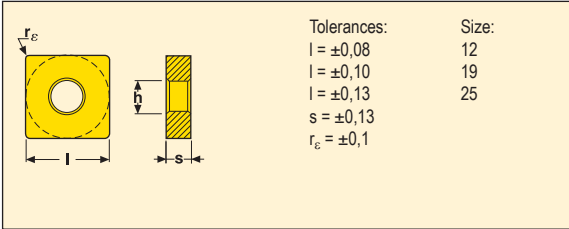

Size	Dimensions in mm			
	l	s	h	$r_e = \text{rep}$
1204	12,70	4,76	5,15	0,8
1906	19,05	6,35	7,92	1,2-2,4
2507	25,40	7,94	9,12	2,4
2509	25,40	9,52	9,12	2,4



Inserts	Part No.	Grades																						
		Coated														Uncoated				Cermets				
		TP0501	TP1501	TP2501	TP3500	TP200	TP40	TH1000	TH1500	TM2000	TM4000	TK1001	TK2001	TS2000	TS2500	CP200	CP500	CP600	HX	KX	883	890	TP1020	TP1030
SNMM-R56	SNMM 250724-R56			■																				
	SNMM-R57	SNMM 190616-R57		■	■																			
190624-R57		■																						
SNMM 250724-R57				■																				
SNMM-R68	SNMM 250924-R68	■		■																				
	SNMM-RR6	SNMM 120408-RR6									■													
SNMM 190612-RR6					■																			
190616-RR6				■	■					■														
190624-RR6				■																				
SNMM 250724-RR6				■	■																			
SNMM-RR9	SNMM 190616-RR9											■												
	SNMM 250724-RR9				■		■																	
SNMM-56	SNMM 190616-56				■																			
	SNMM 250724-56				■																			
SNMM-57	SNMM 190616-57						■																	
	190624-57				■																			
	SNMM 250724-57				■	■																		

■ Stock standard
 Subject to change refer to current price- and stock-list

SNMX

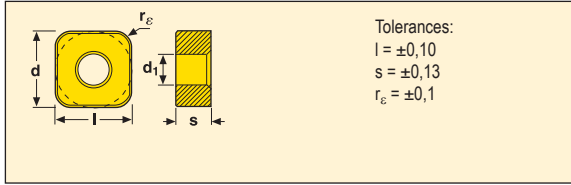

Size	Dimensions in mm			
	l	s	d ₁	r _ε = rep
1911	19,05	11,00	7,75	4,0

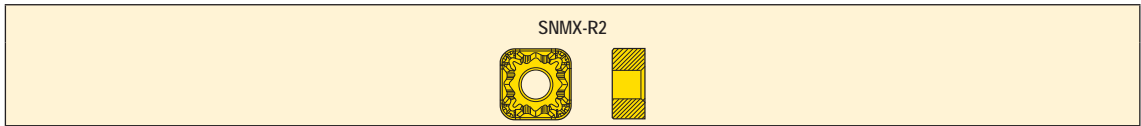

Inserts	Part No.	Grades																						
		Coated												Uncoated		Cermet								
		TP0501	TP1501	TP2501	TP3500	TP200	TP40	TH1000	TH1500	TM2000	TM4000	TK1001	TK2001	TS2000	TS2500	CP200	CP500	CP600	HX	KX	883	890	TP1020	TP1030
SNMX-R2	SNMX 191140-R2	■	■		■																			

SNUN

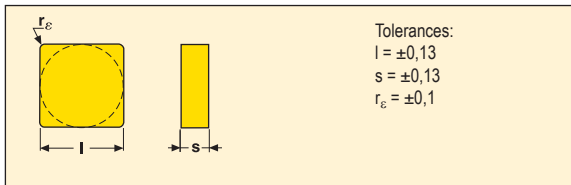

Size	Dimensions in mm		
	l	s	r _ε = rep
1204	12,70	4,76	1,2

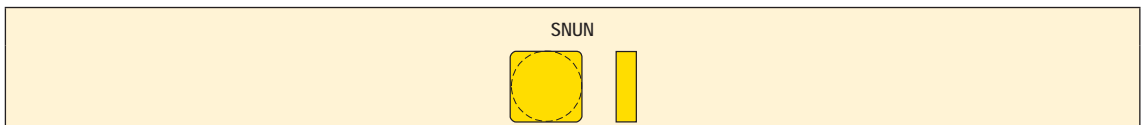

Inserts	Part No.	Grades																						
		Coated												Uncoated		Cermet								
		TP0501	TP1501	TP2501	TP3500	TP200	TP40	TH1000	TH1500	TM2000	TM4000	TK1001	TK2001	TS2000	TS2500	CP200	CP500	CP600	HX	KX	883	890	TP1020	TP1030
SNUN	SNUN 120412											■												

■ Stock standard
 Subject to change refer to current price- and stock-list

TCMT

Tolerances:
 $d = \pm 0,05$
 $d = \pm 0,08$
 $s = \pm 0,05$
 $s = \pm 0,13$
 $r_e = \pm 0,1$

Size:
 11, 16
 22
 11, 16
 22

Size	Dimensions in mm				
	d	l	s	h	$r_e = rep$
1102	6,35	11,0	2,38	2,9	0,2-0,8
16T3	9,53	16,5	3,97	4,5	0,2-1,2
2204	12,70	22,0	4,76	5,6	0,4-0,8

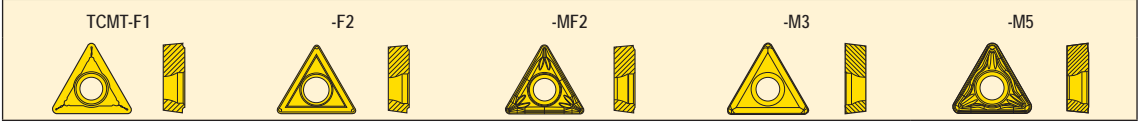

Inserts	Part No.	Grades																							
		Coated														Uncoated				Cermets					
		TP0501	TP1501	TP2501	TP3500	TP200	TP40	TH1000	TH1500	TM2000	TM4000	TK1001	TK2001	TS2000	TS2500	CP200	CP500	CP600	HX	KX	883	890	TP1020	TP1030	
TCMT-F1	TCMT 110202-F1																								
	110204-F1		■	■						■	■						■								
	110208-F1		■	■	■	■	■			■	■						■								
	TCMT 16T302-F1				■						■														
	16T304-F1		■	■	■		■			■	■			■		■									■
	16T308-F1		■	■	■	■	■			■	■			■		■									
16T312-F1		■		■						■															
TCMT-F2	TCMT 16T304-F2				■	■													■						
	16T308-F2				■	■	■			■	■								■						
	TCMT 220404-F2																		■						
	220408-F2				■	■																			
TCMT-MF2	TCMT 110204-MF2			■	■												■								
	110208-MF2			■	■												■								
	TCMT 16T304-MF2			■	■												■								
	16T308-MF2			■	■												■								
TCMT-M3	TCMT 16T304-M3		■	■																					
	16T308-M3		■	■																					
	TCMT 220408-M3		■	■																					
TCMT-M5	TCMT 16T308-M5	■		■			■			■	■	■													
	16T312-M5			■								■				■									

■ Stock standard

Subject to change refer to current price- and stock-list

TCMX

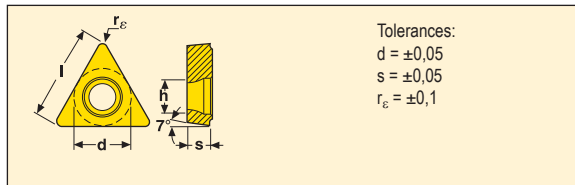

Size	Dimensions in mm				
	d	l	s	h	$r_{\epsilon} = \text{rep}$
16T3	9,53	16,5	3,97	4,5	0,8

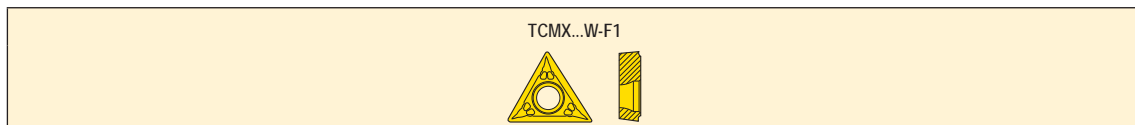

Inserts	Part No.	Grades																						
		Coated												Uncoated		Cermet								
		TP0501	TP1501	TP2501	TP3500	TP200	TP40	TH1000	TH1500	TM2000	TM4000	TK1001	TK2001	TS2000	TS2500	CP200	CP500	CP600	HX	KX	883	890	TP1020	TP1030
TCMX...W-F1	TCMX 16T308W-F1		■	■																				

TDAB

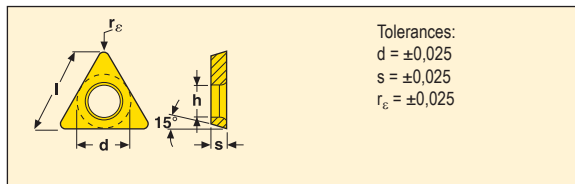

Size	Dimensions in mm				
	d	l	s	h	$r_{\epsilon} = \text{rep}$
06T0	4,064	6,8	1,194	2,36	0,05-0,4

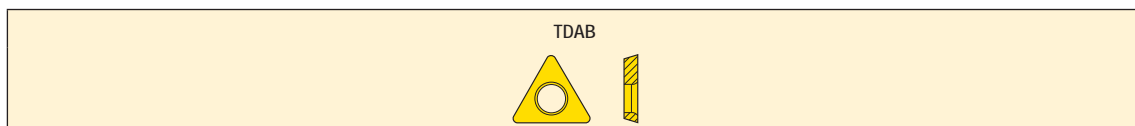

Inserts	Part No.	Grades																					
		Coated												Uncoated		Cermet							
		TP0501	TP1501	TP2501	TP3500	TP200	TP40	TH1000	TH1500	TM2000	TM4000	TK1001	TK2001	TS2000	TS2500	CP200	CP500	CP600	HX	KX	883	890	TP1020
TDAB	TDAB 06T0005															■				■			
	06T002															■				■			
	06T004															■				■			

■ Stock standard
 Subject to change refer to current price- and stock-list

TNMA, TNMG

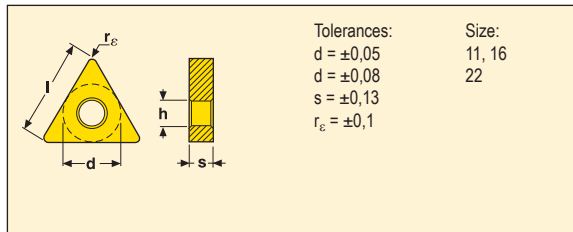

Size	Dimensions in mm				
	d	l	s	h	$r_e = \text{rep}$
1103	6,35	11,0	3,18	2,26	0,4
1603	9,53	16,5	3,18	3,81	0,8
1604	9,53	16,5	4,76	3,81	0,4-1,6
2204	12,70	22,0	4,76	5,15	0,4-1,6

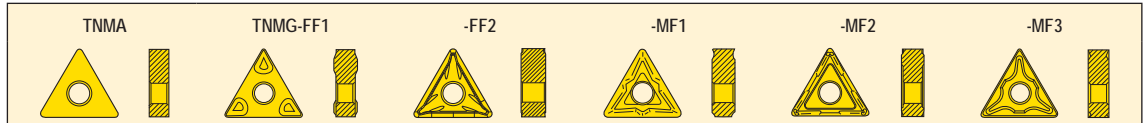

Inserts	Part No.	Grades																						
		Coated														Uncoated				Cermets				
		TP0501	TP1501	TP2501	TP3500	TP200	TP40	TH1000	TH1500	TM2000	TM4000	TK1001	TK2001	TS2000	TS2500	CP200	CP500	CP600	HX	KX	883	890	TP1020	TP1030
TNMA	TNMA 160404										■													
	160408										■	■												
	160412										■	■												
	160416										■													
	TNMA 220408											■												
	220412											■	■											
220416											■	■												
TNMG-FF1	TNMG 160404-FF1																							■
	160408-FF1		■	■																				
TNMG-FF2	TNMG 160404-FF2		■	■	■											■								■
	160408-FF2		■	■	■																			■
TNMG-MF1	TNMG 160404-MF1								■	■			■		■									
	160408-MF1								■	■			■		■	■						■		
	160412-MF1												■		■	■								
TNMG-MF2	TNMG 110304-MF2				■																			
	TNMG 160404-MF2		■	■	■	■																		■
	160408-MF2		■	■	■	■	■																■	■
	160412-MF2			■	■																			
	TNMG 220404-MF2				■																			
220408-MF2			■	■																				
TNMG-MF3	TNMG 160308-MF3				■																			
	TNMG 160404-MF3				■																			
	160408-MF3				■	■	■																	
	TNMG 220404-MF3				■																			
220408-MF3				■																				

■ Stock standard

Subject to change refer to current price- and stock-list

TNMG

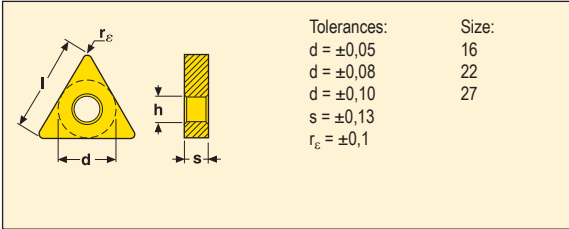

Size	Dimensions in mm				
	d	l	s	h	$r_e = rep$
1603	9,53	16,5	3,18	3,81	0,8
1604	9,53	16,5	4,76	3,81	0,4-1,2
2204	12,70	22,0	4,76	5,15	0,8-1,6
2706	15,88	27,5	6,35	6,35	1,2

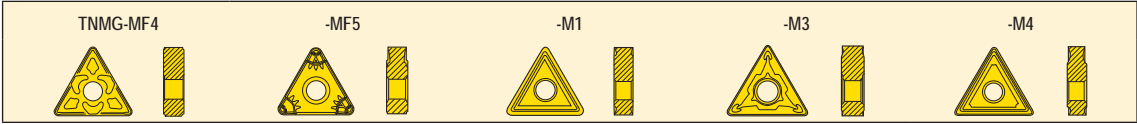

Inserts	Part No.	Grades																						
		Coated														Uncoated				Cermets				
		TP0501	TP1501	TP2501	TP3500	TP200	TP40	TH1000	TH1500	TM2000	TM4000	TK1001	TK2001	TS2000	TS2500	CP200	CP500	CP600	HX	KX	883	890	TP1020	TP1030
TNMG-MF4	TNMG 160404-MF4								■	■														
	160408-MF4				■				■	■			■	■		■								
	160412-MF4								■	■			■	■										
	TNMG 220408-MF4								■	■														
220412-MF4								■	■															
TNMG-MF5	TNMG 160404-MF5							■	■															
	160408-MF5		■	■				■	■				■	■										
	160412-MF5		■	■									■	■										
TNMG-M1	TNMG 160308-M1																					■		
	TNMG 160408-M1																					■		
	TNMG 220408-M1														■							■		
	220412-M1																					■		
	220416-M1																					■		
TNMG-M3	TNMG 160404-M3		■	■	■	■	■						■											
	160408-M3	■	■	■	■	■	■																	
	160412-M3		■	■	■		■																	
	TNMG 220408-M3		■	■	■	■																		
	220412-M3		■	■	■																			
	TNMG 270612-M3			■	■	■																		
TNMG-M4	TNMG 160408-M4												■											

■ Stock standard
 Subject to change refer to current price- and stock-list

Turning – Inserts

TNMG

Tolerances:
 $d = \pm 0,05$
 $d = \pm 0,08$
 $d = \pm 0,10$
 $s = \pm 0,13$
 $r_c = \pm 0,1$

Size:
 16
 22
 27

Size	Dimensions in mm				
	d	l	s	h	$r_c = \text{rep}$
1603	9,53	16,5	3,18	3,81	0,8
1604	9,53	16,5	4,76	3,81	0,4-1,6
2204	12,70	22,0	4,76	5,15	0,4-1,6
2706	15,88	27,5	6,35	6,35	0,8-1,6

TNMG-M5

-M6

-MR3

Inserts	Part No.	Grades																						
		Coated																Uncoated				Cermets		
		TP0501	TP1501	TP2501	TP3500	TP200	TP40	TH1000	TH1500	TM2000	TM4000	TK1001	TK2001	TS2000	TS2500	CP200	CP500	CP600	HX	KX	883	890	TP1020	TP1030
TNMG-M5	TNMG 160308-M5				■		■																	
	TNMG 160404-M5			■	■																			
	160408-M5	■	■	■	■	■	■		■	■	■	■												
	160412-M5	■	■	■	■							■												
	160416-M5												■											
	TNMG 220404-M5			■	■																			
	220408-M5	■	■	■	■	■	■		■	■		■												
	220412-M5	■	■	■	■							■												
	220416-M5	■	■	■	■		■																	
	TNMG 270608-M5				■		■																	
	270612-M5		■	■	■	■	■																	
	270616-M5		■	■	■	■	■																	
TNMG-M6	TNMG 160408-M6		■	■																				
	160412-M6		■	■																				
TNMG-MR3	TNMG 160412-MR3																■					■		
	TNMG 220412-MR3												■		■	■						■		

■ Stock standard
 Subject to change refer to current price- and stock-list

TNMG

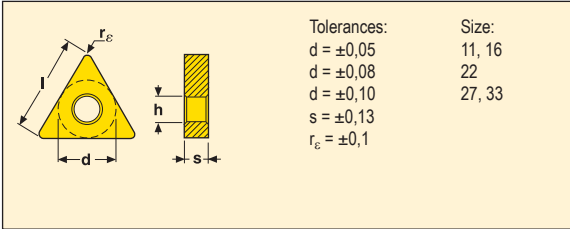

Size	Dimensions in mm				
	d	l	s	h	$r_e = \text{rep}$
1103	6,35	11,0	3,18	2,26	0,4-0,8
1603	9,53	16,5	3,18	3,81	0,4-1,6
1604	9,53	16,5	4,76	3,81	0,8-1,2
2204	12,70	22,0	4,76	5,15	0,4-3,2
2706	15,88	27,5	6,35	6,35	0,8-3,2
3309	19,05	33,0	9,52	7,92	2,4



Inserts	Part No.	Grades																							
		Coated														Uncoated			Cermet						
		TP0501	TP1501	TP2501	TP3500	TP200	TP40	TH1000	TH1500	TM2000	TM4000	TK1001	TK2001	TS2000	TS2500	CP200	CP500	CP600	HX	KX	883	890	TP1020	TP1030	
TNMG-MR4	TNMG 110304-MR4																								
	110308-MR4																					■			
	TNMG 160304-MR4																								
	160308-MR4																					■			
	160316-MR4																					■			
	TNMG 160408-MR4													■									■		
	TNMG 220404-MR4																								
	220408-MR4														■								■		
	220412-MR4														■								■		
	220416-MR4														■								■		
	220424-MR4														■								■		
	220432-MR4														■								■		
	TNMG 270608-MR4														■								■		
	270612-MR4																						■		
270616-MR4																						■			
270632-MR4																						■			
TNMG 330924-MR4																						■			
TNMG-MR6	TNMG 160408-MR6																								
	160412-MR6																								
	TNMG 220408-MR6																								
	220412-MR6																								

■ Stock standard
 Subject to change refer to current price- and stock-list

TNMG, TNMM

Tolerances:
 $d = \pm 0,05$
 $d = \pm 0,08$
 $d = \pm 0,10$
 $s = \pm 0,13$
 $r_c = \pm 0,1$

Size:
 16
 22
 27, 33

Size	Dimensions in mm				
	d	l	s	h	$r_c = \text{rep}$
1604	9,53	16,5	4,76	3,81	0,4-1,2
2204	12,70	22,0	4,76	5,15	0,8-1,6
2706	15,88	27,5	6,35	6,35	1,2-1,6
3309	19,05	33,0	9,52	7,92	2,4

TNMG-MR7

-UX*

TNMM-R4

-R6

Inserts	Part No.	Grades																							
		Coated																Uncoated				Cermet			
		TP0501	TP1501	TP2501	TP3500	TP200	TP40	TH1000	TH1500	TM2000	TM4000	TK1001	TK2001	TS2000	TS2500	CP200	CP500	CP600	HX	KX	883	890	TP1020	TP1030	
TNMG-MR7	TNMG 160408-MR7		■		■		■																		
	160412-MR7		■		■																				
	TNMG 220408-MR7				■		■																		
	220412-MR7				■		■																		
	TNMG 270612-MR7			■	■																				
	270616-MR7			■	■	■																			
TNMG 330924-MR7			■	■	■	■																			
TNMG-UX	TNMG 160404R-UX			■										■											
	160404L-UX			■										■											
	160408R-UX			■										■											
	160408L-UX			■										■											
TNMM-R4	TNMM 160408-R4			■	■																				
	160412-R4			■																					
	TNMM 220408-R4			■	■																				
	220412-R4		■	■	■	■																			
	220416-R4		■	■	■	■																			
TNMM-R6	TNMM 160404-R6				■																				
	160408-R6																								
	TNMM 220408-R6																								
	220416-R6				■																				

■ Stock standard

Subject to change refer to current price- and stock-list

*Right-hand version shown

TNMX

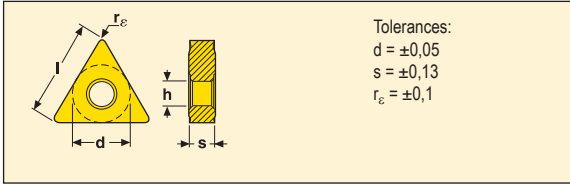

Size	Dimensions in mm				
	d	l	s	h	$r_e = \text{rep}$
1604	9,53	16,5	4,76	3,81	0,8-1,2

TNMX...W-M3



Inserts	Part No.	Grades																						
		Coated														Uncoated			Cermet					
		TP0501	TP1501	TP2501	TP3500	TP200	TP40	TH1000	TH1500	TM2000	TM4000	TK1001	TK2001	TS2000	TS2500	CP200	CP500	CP600	HX	KX	883	890	TP1020	TP1030
TNMX...W-M3	TNMX 160408W-M3		■	■																				
	160412W-M3		■																					

VBGT

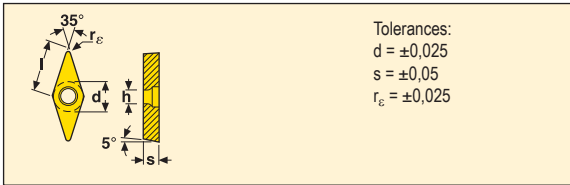

Size	Dimensions in mm				
	d	l	s	h	$r_e = \text{rep}$
1102	6,350	11,0	2,38	2,9	0,1
1604	9,525	16,0	4,76	4,5	0,1

VBGT-F1



Inserts	Part No.	Grades																						
		Coated														Uncoated			Cermet					
		TP0501	TP1501	TP2501	TP3500	TP200	TP40	TH1000	TH1500	TM2000	TM4000	TK1001	TK2001	TS2000	TS2500	CP200	CP500	CP600	HX	KX	883	890	TP1020	TP1030
VBGT-F1	VBGT 110201-F1															■								
	VBGT 160401-F1															■								

■ Stock standard
 Subject to change refer to current price- and stock-list

VBMT

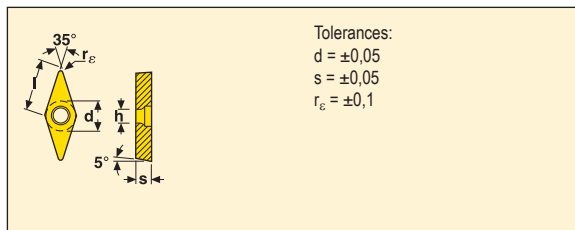

Size	Dimensions in mm				
	d	l	s	h	$r_e = \text{rep}$
1102	6,35	11,0	2,38	2,9	0,2-0,8
1103	6,35	11,0	3,18	2,9	0,2-0,8
1604	9,53	16,0	4,76	4,5	0,2-1,2

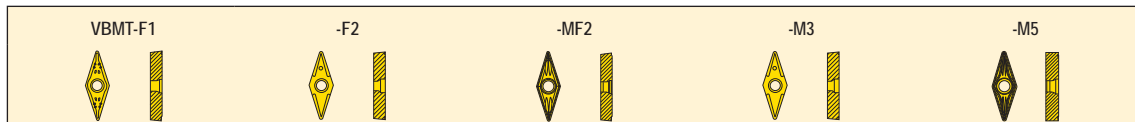

Inserts	Part No.	Grades																							
		Coated														Uncoated		Cermet							
		TP0501	TP1501	TP2501	TP3500	TP200	TP40	TH1000	TH1500	TM2000	TM4000	TK1001	TK2001	TS2000	TS2500	CP200	CP500	CP600	HX	KX	883	890	TP1020	TP1030	
VBMT-F1	VBMT 110202-F1			■	■												■								■
	110204-F1			■	■	■											■							■	■
	110208-F1			■													■								
	VBMT 110302-F1			■	■												■								
	110304-F1			■	■												■								
	110308-F1			■													■								
	VBMT 160402-F1			■	■												■								
	160404-F1		■	■	■	■		■			■			■		■	■							■	■
	160408-F1		■	■	■	■			■			■	■			■	■							■	■
160412-F1		■	■	■																					
VBMT-F2	VBMT 160404-F2				■	■	■			■	■							■							
	160408-F2				■	■	■			■	■		■		■			■							
	160412-F2				■		■				■														
	VBMT 160402-F2																								
VBMT-MF2	VBMT 110202-MF2																■	■						■	
	110204-MF2			■	■												■	■						■	
	VBMT 160402-MF2					■											■								
	160404-MF2		■	■	■	■					■						■							■	■
	160408-MF2		■	■	■	■					■						■							■	■
	160412-MF2		■	■	■																				
VBMT-M3	VBMT 160404-M3			■	■							■	■												
	160408-M3		■	■	■							■													
	160412-M3			■	■																				
	VBMT 160408-M5		■	■	■	■		■			■		■												

■ Stock standard

Subject to change refer to current price- and stock-list

VCGR

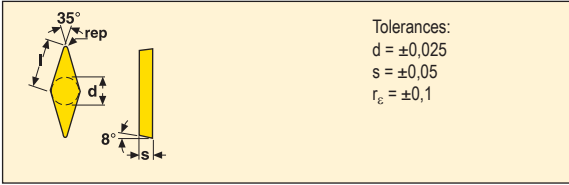

Size	Dimensions in mm			
	d	l	s	$r_e = rep$
1604	9,525	16,6	4,76	0,4-0,8

VCGR



Inserts	Part No.	Grades																						
		Coated												Uncoated		Cermets								
		TP0501	TP1501	TP2501	TP3500	TP200	TP40	TH1000	TH1500	TM2000	TM4000	TK1001	TK2001	TS2000	TS2500	CP200	CP500	CP600	HX	KX	883	890	TP1020	TP1030
VCGR	VCGR 160404														■							■		
	160408														■							■		

VCGT

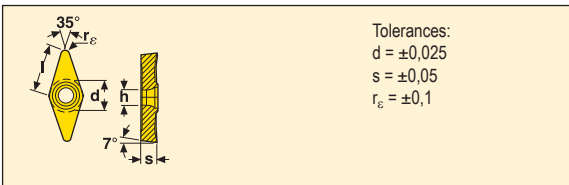

Size	Dimensions in mm				
	d	l	s	h	$r_e = rep$
1103	6,350	11,1	3,18	2,8	0,2-0,4
1604	9,525	16,6	4,76	4,4	0,2-1,2

VCGT-AL



Inserts	Part No.	Grades																						
		Coated												Uncoated		Cermets								
		TP0501	TP1501	TP2501	TP3500	TP200	TP40	TH1000	TH1500	TM2000	TM4000	TK1001	TK2001	TS2000	TS2500	CP200	CP500	CP600	HX	KX	883	890	TP1020	TP1030
VCGT-AL	VCGT 110302F-AL																			■				
	110304F-AL																			■				
	VCGT 160402F-AL																			■				
	160404F-AL																			■				
	160408F-AL																			■				
	160412F-AL																			■				

■ Stock standard

Subject to change refer to current price- and stock-list

VNMG, VNMU

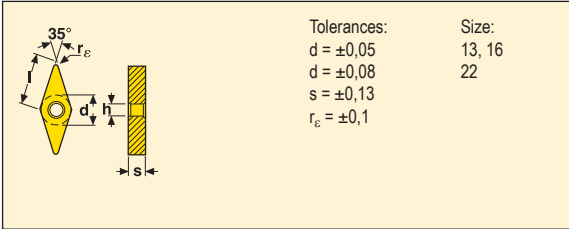

Size	Dimensions in mm				
	d	l	s	h	$r_e = \text{rep}$
1304	7,937	13	4,76	3,81	0,4-0,8
1604	9,525	16	4,76	3,81	0,2-1,2
2204	12,700	22	4,76	5,15	0,8-1,2



Inserts	Part No.	Grades																						
		Coated														Uncoated				Cermets				
		TP0501	TP1501	TP2501	TP3500	TP200	TP40	TH1000	TH1500	TM2000	TM4000	TK1001	TK2001	TS2000	TS2500	CP200	CP500	CP600	HX	KX	883	890	TP1020	TP1030
VNMG-FF1	VNMG 160404-FF1		■																					
VNMG-FF2	VNMG 160402-FF2		■	■												■								■
	160404-FF2		■	■												■								■
	160408-FF2		■	■																				■
VNMG-MF2	VNMG 160404-MF2		■	■																				
	160408-MF2	■	■	■																				
	160412-MF2		■	■																				
VNMG-MF3	VNMG 160404-MF3				■																			
	160408-MF3					■																		
VNMG-MF4	VNMG 160404-MF4							■	■				■	■										
	160408-MF4							■	■				■	■										
VNMG-MF5	VNMG 160408-MF5																							■
VNMG-M3	VNMG 160404-M3		■	■	■	■									■									
	160408-M3	■	■	■	■	■									■									
VNMG-MR4	VNMG 160408-MR4																							
	160412-MR4																							
	VNMG 220408-MR4-203																							
	220412-MR4-203																							
VNMU-M3	VNMU 130404-M3		■	■	■																			
	130408-M3	■	■	■	■									■										

■ Stock standard
 Subject to change refer to current price- and stock-list

WCMT

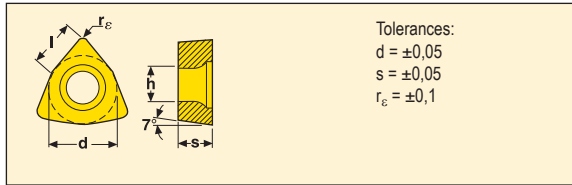

Size	Dimensions in mm				
	d	l	s	h	$r_e = \text{rep}$
06T3	9,53	6,5	3,97	4,5	0,8
06T3..W	9,53	6,6	3,97	4,5	0,8

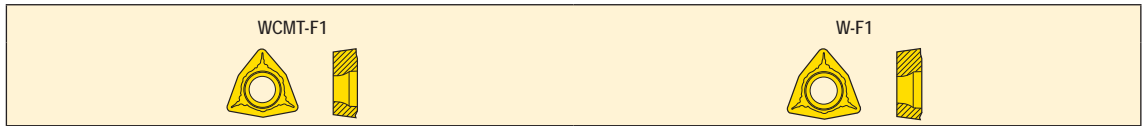

Inserts	Part No.	Grades																						
		Coated												Uncoated		Cermet								
		TP0501	TP1501	TP2501	TP3500	TP200	TP40	TH1000	TH1500	TM2000	TM4000	TK1001	TK2001	TS2000	TS2500	CP200	CP500	CP600	HX	KX	883	890	TP1020	TP1030
WCMT-F1	WCMT 06T308-F1			■												■								
	WCMT 06T308W-F1			■												■								

WNGG

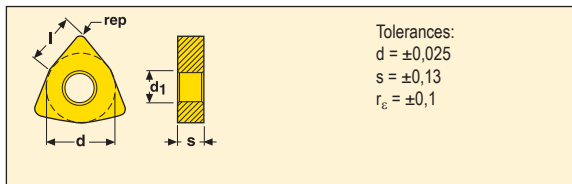

Size	Dimensions in mm				
	d	l	s	h	$r_e = \text{rep}$
0604	9,525	6,6	4,76	3,81	0,2
0804	12,700	8,7	4,76	5,15	0,1-0,8



Inserts	Part No.	Grades																						
		Coated												Uncoated		Cermet								
		TP0501	TP1501	TP2501	TP3500	TP200	TP40	TH1000	TH1500	TM2000	TM4000	TK1001	TK2001	TS2000	TS2500	CP200	CP500	CP600	HX	KX	883	890	TP1020	TP1030
WNGG-MF1	WNGG 060402-MF1												■		■	■						■		
	WNGG 080401-MF1												■											
	080402-MF1												■											
	080404-MF1												■											
	080408-MF1												■											

■ Stock standard

Subject to change refer to current price- and stock-list

WNMA, WNMG

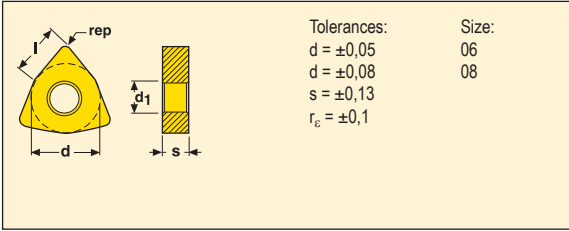

Size	Dimensions in mm				
	d	l	s	h	$r_e = rep$
0604	9,53	6,6	4,76	3,81	0,4-1,2
0804	12,70	8,7	4,76	5,15	0,4-1,6

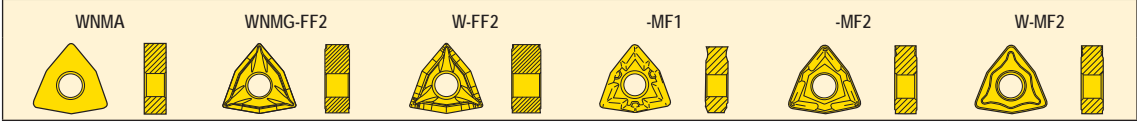

Inserts	Part No.	Grades																							
		Coated														Uncoated				Cermet					
		TP0501	TP1501	TP2501	TP3500	TP200	TP40	TH1000	TH1500	TM2000	TM4000	TK1001	TK2001	TS2000	TS2500	CP200	CP500	CP600	HX	KX	883	890	TP1020	TP1030	
WNMA	WNMA 060408											■	■												
	060412											■	■												
	WNMA 080408											■	■												
	080412											■	■												
	080416											■	■												
WNMG-FF2	WNMG 060404-FF2		■	■	■											■									■
	060408-FF2		■	■																					■
	WNMG 080404-FF2		■	■																					
	080408-FF2		■	■																					
WNMG...W-FF2	WNMG 060404W-FF2			■																					■
	060408W-FF2			■																					■
WNMG-MF1	WNMG 060404-MF1								■	■			■		■	■							■		
	060408-MF1								■	■			■		■	■							■		
	060412-MF1															■									
	WNMG 080404-MF1							■		■	■			■		■									
	080408-MF1						■		■	■			■		■										
WNMG-MF2	WNMG 060404-MF2		■	■	■	■																		■	■
	060408-MF2		■	■	■	■																			■
	060412-MF2			■																					
	WNMG 080404-MF2		■	■					■	■															
	080408-MF2		■	■		■			■	■															
	080412-MF2		■						■	■															
WNMG...W-MF2	WNMG 060404W-MF2		■	■																					■
	060408W-MF2		■	■																					■
	WNMG 080404W-MF2			■																					
	080408W-MF2		■	■																					

■ Stock standard

Subject to change refer to current price- and stock-list

WNMG

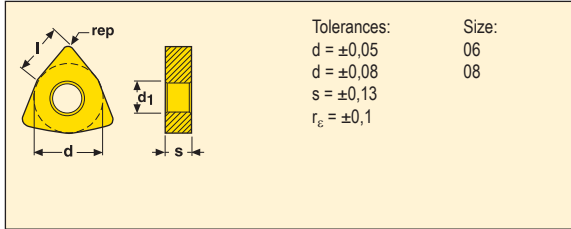

Size	Dimensions in mm				
	d	l	s	h	$r_e = rep$
0604	9,53	6,6	4,76	3,81	0,4-1,2
0804	12,70	8,7	4,76	5,15	0,4-1,6

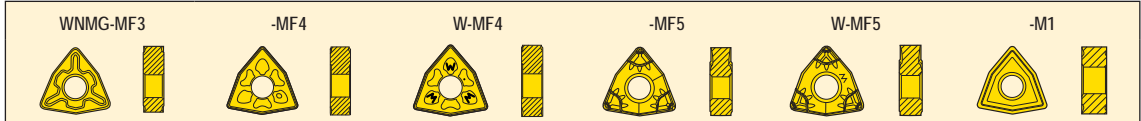

Inserts	Part No.	Grades																						
		Coated																Uncoated				Cermet		
		TP0501	TP1501	TP2501	TP3500	TP200	TP40	TH1000	TH1500	TM2000	TM4000	TK1001	TK2001	TS2000	TS2500	CP200	CP500	CP600	HX	KX	883	890	TP1020	TP1030
WNMG-MF3	WNMG 060408-MF3				■																			
	WNMG 080404-MF3						■																	
	080408-MF3				■		■			■		■												
WNMG-MF4	WNMG 060404-MF4								■	■								■						
	060408-MF4				■					■	■													
	060412-MF4									■	■													
	WNMG 080404-MF4									■	■													
	080408-MF4				■	■				■	■				■	■		■						
080412-MF4				■					■	■				■	■									
WNMG...W-MF4	WNMG 060408W-MF4									■	■													
	WNMG 080408W-MF4									■	■													
	080412W-MF4										■													
WNMG-MF5	WNMG 060404-MF5				■																			
	060408-MF5				■	■																		
	060412-MF5				■	■																		
	WNMG 080408-MF5				■	■				■	■					■	■							
	080412-MF5				■	■				■	■				■	■								
080416-MF5					■																			
WNMG...W-MF5	WNMG 060408W-MF5				■	■																		
	WNMG 080408W-MF5				■	■																		
WNMG-M1	WNMG 080404-M1																					■		
	080408-M1																					■		
	080412-M1																					■		

■ Stock standard

Subject to change refer to current price- and stock-list

WNMG

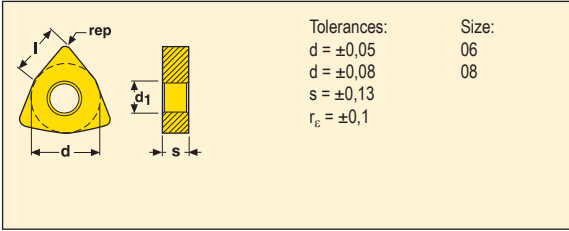

Size	Dimensions in mm				
	d	l	s	h	$r_e = rep$
0604	9,53	6,6	4,76	3,81	0,2-1,2
0804	12,70	8,7	4,76	5,15	0,4-1,6
0806	12,70	8,7	6,35	5,15	0,8-1,6

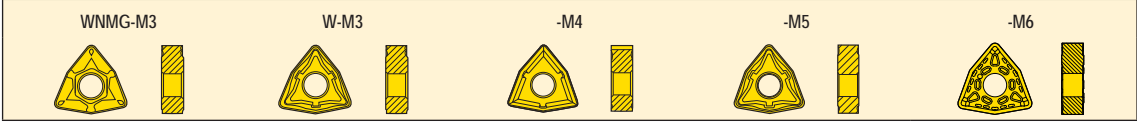

Inserts	Part No.	Grades																						
		Coated														Uncoated				Cermets				
		TP0501	TP1501	TP2501	TP3500	TP200	TP40	TH1000	TH1500	TM2000	TM4000	TK1001	TK2001	TS2000	TS2500	CP200	CP500	CP600	HX	KX	883	890	TP1020	TP1030
WNMG-M3	WNMG 060402-M3			■																				
	060404-M3		■		■	■																		
	060408-M3	■	■	■	■	■	■					■												
	060412-M3	■	■	■	■		■																	
	WNMG 080404-M3		■	■	■	■						■												
	080408-M3	■	■	■	■	■	■					■												
	080412-M3	■	■	■	■							■												
	080416-M3			■																				
WNMG...W-M3	WNMG 060408W-M3		■	■								■												
	060412W-M3		■	■																				
	WNMG 080408W-M3	■	■	■								■												
	080412W-M3	■	■	■								■												
WNMG-M4	WNMG 080408-M4											■												
	080412-M4											■												
WNMG-M5	WNMG 060408-M5	■	■	■	■	■						■	■											
	060412-M5	■		■	■							■												
	WNMG 080408-M5	■	■	■	■	■	■		■	■	■	■	■											
	080412-M5	■	■	■	■	■	■	■	■	■	■	■	■											
	080416-M5	■	■	■	■							■												
	WNMG 080608-M5				■																			
	080612-M5		■	■	■																			
	080616-M5		■	■	■																			
WNMG-M6	WNMG 080408-M6	■	■	■	■							■												
	080412-M6	■	■	■	■							■												
	080416-M6	■	■	■																				
	WNMG 080612-M6	■	■	■																				
	080616-M6		■																					

■ Stock standard
 Subject to change refer to current price- and stock-list

WNMG, WNMM

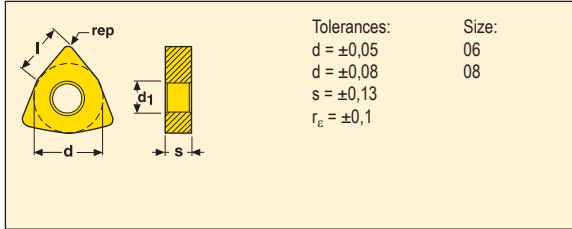

Size	Dimensions in mm				
	d	l	s	h	r _e = rep
0604	9,53	6,6	4,76	3,81	0,8-1,2
0804	12,70	8,7	4,76	5,15	0,8-1,6
0806	12,70	8,7	6,35	5,15	1,2



Inserts	Part No.	Grades																							
		Coated														Uncoated		Cermet							
		TP0501	TP1501	TP2501	TP3500	TP200	TP40	TH1000	TH1500	TM2000	TM4000	TK1001	TK2001	TS2000	TS2500	CP200	CP500	CP600	HX	KX	883	890	TP1020	TP1030	
WNMG...W-M6	WNMG 080408W-M6		■	■																					
	080412W-M6		■	■																					
WNMG-MR3	WNMG 060408-MR3											■			■	■							■		
	060412-MR3											■			■	■									
WNMG-MR6	WNMG 080408-MR6		■	■	■																				
	080412-MR6		■		■																				
	WNMG 080612-MR6					■																			
WNMG-MR7	WNMG 080408-MR7			■	■	■		■				■	■												
	080412-MR7		■	■	■						■	■	■												
	080416-MR7		■	■	■							■													
WNMM-R6	WNMM 080408-R6				■			■																	
	080412-R6								■																

■ Stock standard
 Subject to change refer to current price- and stock-list

CCGW

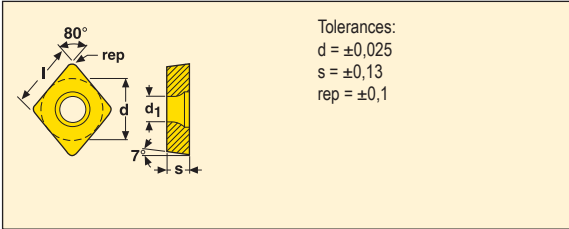

Size	Dimensions in mm				
	d	l	s	d ₁	rep
0602	6,350	6,5	2,38	2,9	0,2-0,8
09T3	9,525	9,7	3,97	4,5	0,4-0,8
1204	12,700	12,9	4,76	5,6	0,4-0,8



Inserts	Part No.	Grades												Toolholders						
		Uncoated						Coated						External	Internal					
		CBN010	CBN10	CBN100	CBN150	CBN170	CBN200	CBN300	CBN500	CBN600	CBN010P	CBN060K	CBN160C			CBN300P	CBN400C			
CCGW	060204E-L1-B	■					■						■				SCLCR/L..06	SCLCR/L06		
	060208E-L1-B						■										SCGCR/L..06	..SCFCR/L06		
																	SCDCR/L..06	SCACL..06		
CCGW	060204S-01020-L1-B	■															SCFCR/L..06	SCECL..06		
	060204S-01525-L1-B												■				SCACR/L..06	..SCDCL06		
	060208S-01525-L1-B																SCECL..06			
	060208S-02020-L1-B						■													
CCGW	060202S-01020-LF						■													
	060204S-01020-LF	■					■													
	060208S-01020-LF						■													
CCGW	060208S-L1-WZP-B																■	SCLCR/L..06	...SCLCR/L06	
CCGW	09T304E-L1-B	■					■										■	SCLCR/L..09	SCLCR/L09	
	09T308E-L1-B	■					■										■	..SCFCR/L09	SCACL..09	
																		SCDCR/L..09	SCACL..09	
CCGW	09T304S-01020-L1-B	■																SCFCR/L..09	SCECL..09	
	09T304S-01525-L1-B																	SCACR/L..09	..SCDCL09	
	09T308S-01020-L1-B	■		■														SCECL..09		
	09T308S-01525-L1-B																			
	09T308S-02020-L1-B						■													
CCGW	09T304S25-02020-L1B						■													
	09T308S25-02020-L1B						■													
CCGW	09T304S-01020-LF	■					■													
	09T308S-01020-LF						■													
CCGW	09T304E-L1-WZ-B	■																■	SCLCR/L..09	..SCLCR/L09
CCGW	09T304S-01020-L1WZB	■																		
	09T304S-01525L1WZB																	■		
	09T308S-01525L1WZB																	■		
	09T304S-L1-WZP-B																	■		
	09T308S-L1-WZP-B																	■		
CCGW	120404S-L0		■															■	SCLCR/L..12	***
	120404S-01020-L1-B	■																		
	120408S-01020-L1-B	■																		
	120408S-02020-L1-B						■													

■ Stock standard

Subject to change refer to current price- and stock-list

***For information, contact your local Seco office

Tip sizes, see page(s) 70
 Edge preparation, see page(s) 67

CCMW

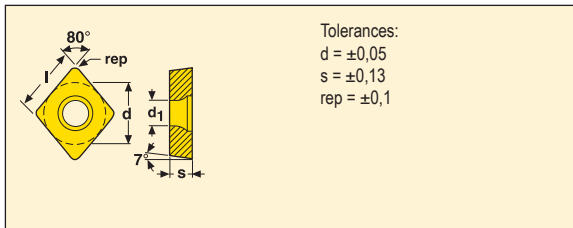

Size	Dimensions in mm				
	d	l	s	d ₁	rep
09T3	9,52	9,70	3,97	4,5	0,8

CCMW...-B

Inserts	Part No.	Grades														Toolholders		
		Uncoated							Coated							External	Internal	
		CBN010	CBN10	CBN100	CBN150	CBN170	CBN200	CBN300	CBN500	CBN600	CBN010P	CBN060K	CBN160C	CBN300P	CBN400C			
CCMW	CCMW 09T308E-L0-B		■														SCLCR/L...09	...SCLCR/L09
																	SCGCR/L...09	...SCFCR/L09
																	SCDCR/L...09	SCACL...09
																	SCFCR/L...09	SCECL...09
																	SCACR/L...09	...SCDCL09
																	SCECL...09	

■ Stock standard
 Subject to change refer to current price- and stock-list
 ***For information, contact your local Seco office

Tip sizes, see page(s) 70
 Edge preparation, see page(s) 67

CNGA

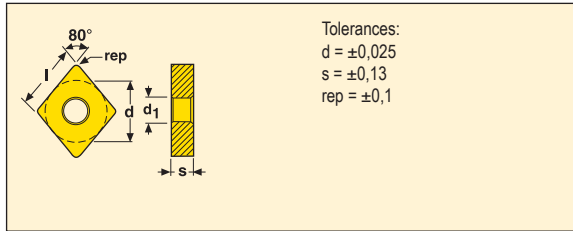

Size	Dimensions in mm				
	d	l	s	d ₁	rep
1204	12,700	12,90	4,76	5,15	0,4-1,2



Inserts	Part No.	Grades													Toolholders				
		Uncoated						Coated							External	Internal			
		CBN010	CBN10	CBN100	CBN150	CBN170	CBN200	CBN300	CBN500	CBN600	CBN010P	CBN060K	CBN160C	CBN300P			CBN400C		
CNGA	CNGA 120408E-L1-B						■											DCLNR/L..12	..-PCLNR/L12
	CNGA 120404S-01020-L1-B	■																PCLNR/L..12	..-MCLNR/L12
	120408S-01020-L1-B	■																	
	120408S-01525-L1-B				■							■	■						
	120408S-02020-L1-B						■												
	120412S-01020-L1-B	■																	
	120412S-01525-L1-B				■							■	■						
	CNGA 120408E25-L1-U					■													
	CNGA 120404S-01525-L1-U											■							
	120408S-01020-L1-U	■																	
	120408S-01525-L1-U												■						
	120412S-01525-L1-U												■						
	CNGA 120408S25-02020-L1B						■												
	CNGA 120408S-01020-L1WZB	■																	
	120408S-01525L1WZB												■	■					
	120412S-01525L1WZB													■					
	CNGA 120408S-01020-L1WZU	■																	
	120408S-01525L1WZU												■						
	120412S-01525L1WZU												■						
	CNGA 120408S-L1-WZN-B												■						
	120408S-L1-WZP-B	■											■						
	CNGA 120408S-L1-WZN-U												■						

■ Stock standard
 Subject to change refer to current price- and stock-list
 ***For information, contact your local Seco office

Tip sizes, see page(s) 70
 Edge preparation, see page(s) 67

CNMN

Tolerances:
 $d = \pm 0,05$
 $d = \pm 0,08$
 $s = \pm 0,13$
 $rep = \pm 0,1$

Size:
 09
 12

Size	Dimensions in mm			
	d	l	s	rep
0903	9,53	9,7	3,18	0,8-1,6
1204	12,70	12,9	4,76	0,8-1,6

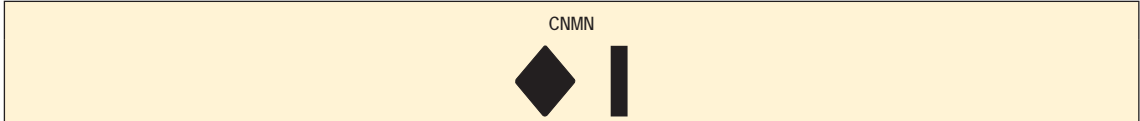

Inserts	Part No.	Grades												Toolholders				
		Uncoated						Coated						External	Internal			
		CBN010	CBN10	CBN100	CBN150	CBN170	CBN200	CBN300	CBN500	CBN600	CBN010P	CBN060K	CBN160C			CBN300P	CBN400C	
CNMN	CNMN 090308S							■						■		CCLNR/L...09 CCBNR/L...09	...-CCLNR/L09	
	090308S-02020								■					■				
	090308S-02020P									■								
	090312S							■						■				
	090316S							■						■				
	090316S-02020								■									
	CNMN 090308S-WZ							■								CCLNR/L...09		
	CNMN 120412S							■							■		CCLNR/L...12 CCBNR/L...12	...-MCLNR/L12 (without pin)
	120412S-02020													■				
	120412S-02020P									■								
	120416S							■										
	120416S-02020													■				
	120416S-02020P									■								
	CNMN 120408S-WZ							■								CCLNR/L...12		
	120408S-02020-WZ														■			

■ Stock standard
 Subject to change refer to current price- and stock-list
 ***For information, contact your local Seco office

Tip sizes, see page(s) 70
 Edge preparation, see page(s) 67

DCGW

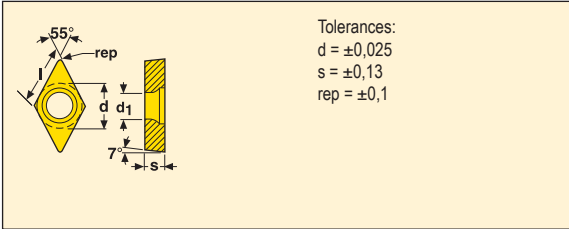

Size	Dimensions in mm				
	d	l	s	d ₁	rep
0702	6,350	7,8	2,38	2,9	0,2-0,8
11T3	9,525	11,6	3,97	4,5	0,2-0,8

DCGW...-B



Inserts	Part No.	Grades												Toolholders				
		Uncoated						Coated						External	Internal			
		CBN010	CBN10	CBN100	CBN150	CBN170	CBN200	CBN300	CBN500	CBN600	CBN1010P	CBN060K	CBN160C			CBN300P	CBN400C	
DCGW	DCGW 070204E-L1-B	■					■										SDHCR/L..07	..-SDUCR/L07
	DCGW 070202S-01020-L1-B				■												SDJCR/L..07	..-SDQCR/L07
	070202S-01525-L1-B																SDACR/L..07	
	070204S-01020-L1-B	■			■												SDNCN..07	
	070204S-01525-L1-B																	
	070204S-02020-L1-B																	
	070208S-01525-L1-B																	
	070208S-02020-L1-B																	
	DCGW 070204S25-02020-L1B																	
	DCGW 11T302E-L1-B																SDHCR/L..11	..-SDUCR/L11
	11T304E-L1-B	■															SDJCR/L..11	..-SDQCR/L11
	11T308E-L1-B	■															SDNCN..11	
	DCGW 11T302S-01020-L1-B	■																
	11T304S-01020-L1-B	■																
	11T304S-01525-L1-B																	
	11T304S-02020-L1-B																	
	11T308S-01020-L1-B	■																
	11T308S-01525-L1-B																	
	11T308S-02020-L1-B																	
	DCGW 11T304S25-02020-L1B																	
	11T308S25-02020-L1B																	

■ Stock standard
 Subject to change refer to current price- and stock-list
 ***For information, contact your local Seco office

Tip sizes, see page(s) 70
 Edge preparation, see page(s) 67

DCMW

Tolerances:
 $d = \pm 0,05$
 $s = \pm 0,13$
 $rep = \pm 0,1$

Size	Dimensions in mm				
	d	l	s	d ₁	rep
0702	6,35	7,80	2,38	2,9	0,4

DCMW...-B

Inserts	Part No.	Grades														Toolholders			
		Uncoated							Coated							External	Internal		
		CBN010	CBN10	CBN100	CBN150	CBN170	CBN200	CBN300	CBN500	CBN600	CBN010P	CBN060K	CBN160C	CBN300P	CBN400C				
DCMW	DCMW 070204E-L0-B	■															SDHCR/L..07 SDJCR/L..07 SDACR/L..07 SDNCN..07	...SDUCR/L07 ...SDQCR/L07	

■ Stock standard
 Subject to change refer to current price- and stock-list
 ***For information, contact your local Seco office

Tip sizes, see page(s) 70
 Edge preparation, see page(s) 67

DNGA

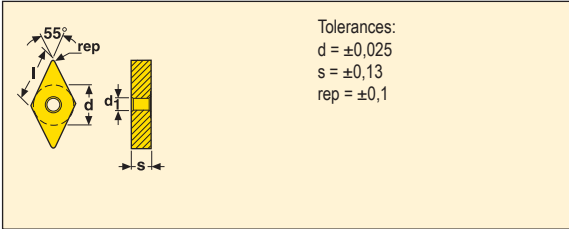

Size	Dimensions in mm				
	d	l	s	d ₁	rep
1504	12,700	15,00	4,76	5,15	0,4-1,2
1506	12,700	15,00	6,35	5,15	0,4-1,2



Inserts	Part No.	Grades													Toolholders			
		Uncoated						Coated							External	Internal		
		CBN010	CBN10	CBN100	CBN150	CBN170	CBN200	CBN300	CBN500	CBN600	CBN1010P	CBN060K	CBN160C	CBN300P			CBN400C	
DNGA	DNGA 150404S-01020-L1-B	■															DDJNR/L..15* DDHNR/L..15 PDJNR/L..15 DDJNR/L..15	A32T-PDUNR/L15** A40U-PDUNR/L15** A50V-PDUNR/L15**
	150408S-01020-L1-B	■																
	150408S-01525-L1-B				■							■	■					
	150408S-02020-L1-B						■											
	150412S-01525-L1-B												■					
	DNGA 150408S25-02020-L1B						■											
	DNGA 150408S-01525-L1-U												■					
	DNGA 150604S-01020-L1-B	■															PDJNR/L..15 DDJNR/L..15	A32T-PDUNR/L15 A40U-PDUNR/L15 A50V-PDUNR/L15 S32U-PDUNR/L15 S40V-PDUNR/L15 S50W-PDUNR/L15
	150608S-01020-L1-B	■																
	150608S-01525-L1-B				■							■	■					
	150608S-02020-L1-B						■											
	150612S-01020-L1-B	■																
	150612S-01525-L1-B												■					
	DNGA 150608E25-L1-U					■												
	DNGA 150604S-01525-L1-U												■					
	150608S-01525-L1-U												■					
	150612S-01525-L1-U												■					
	DNGA 150608S01020L1WZ93B	■																

■ Stock standard
 Subject to change refer to current price- and stock-list
 ***For information, contact your local Seco office

Tip sizes, see page(s) 70
 Edge preparation, see page(s) 67
 *Shim DDN150616 for insert DN..1504., to be ordered separately
 **Shim PDD150412 for insert DN..1504., to be ordered separately

DNGN

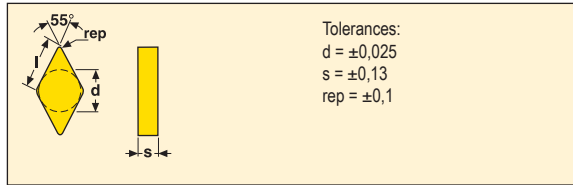

Size	Dimensions in mm			
	d	l	s	rep
1103	9,525	11,6	3,18	0,8-1,2

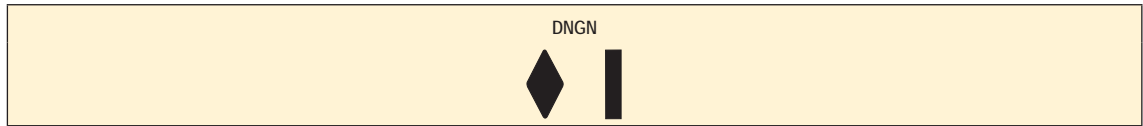

Inserts	Part No.	Grades												Toolholders				
		Uncoated						Coated						External	Internal			
		CBN010	CBN10	CBN100	CBN150	CBN170	CBN200	CBN300	CBN500	CBN600	CBN010P	CBN060K	CBN160C			CBN300P	CBN400C	
DNGN	DNGN 110308E25						■										CDJNR/L..11	***
	DNGN 110308S-01020	■																
	110312S-01020	■																

DNMA

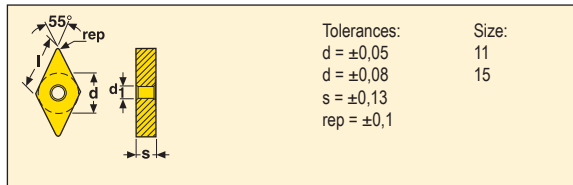

Size	Dimensions in mm				
	d	l	s	d ₁	rep
1104	9,52	11,6	4,76	3,81	0,8-1,6
1504	12,70	15,0	4,76	5,15	0,8-1,6

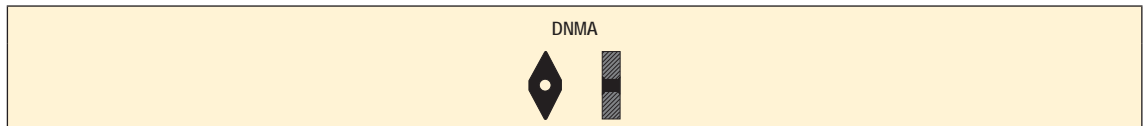

Inserts	Part No.	Grades												Toolholders				
		Uncoated						Coated						External	Internal			
		CBN010	CBN10	CBN100	CBN150	CBN170	CBN200	CBN300	CBN500	CBN600	CBN010P	CBN060K	CBN160C			CBN300P	CBN400C	
DNMA	DNMA 110408S							■									DDJNR/L..11-C	A..DDUNR/L11-C
	110416S							■									DDNN..11-C	
	DNMA 150408S							■									DDHNR/L..15*	A32T-PDUNR/L15**
	150416S							■									DDJNR/L..15*	A40U-PDUNR/L15** A50V-PDUNR/L15**

■ Stock standard
 Subject to change refer to current price- and stock-list
 **For information, contact your local Seco office

Tip sizes, see page(s) 70
 Edge preparation, see page(s) 67
 *Shim DDN150616 for insert DN..1504... to be ordered separately
 **Shim PDD150412 for insert DN.A1504... to be ordered separately

DNMN

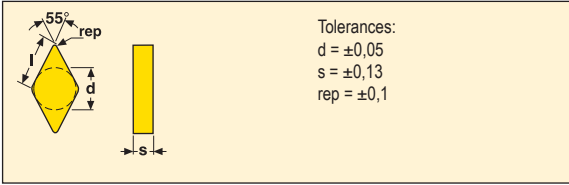

Size	Dimensions in mm			
	d	l	s	rep
1103	9,53	11,6	3,18	0,8-1,2

DNMN



Inserts	Part No.	Grades														Toolholders			
		Uncoated							Coated							External	Internal		
		CBN010	CBN10	CBN100	CBN150	CBN170	CBN200	CBN300	CBN500	CBN600	CBN1010P	CBN060K	CBN160C	CBN300P	CBN400C				
DNMN	110308S 110312S							■										CDJNR/L..11 CDNNN..11	***

RCCG

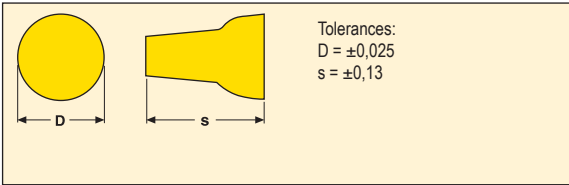

Size	Dimensions in mm	
	D	s
6.35	6,35	9,13

RCCG



Inserts	Part No.	Grades														Toolholders			
		Uncoated							Coated							External	Internal		
		CBN010	CBN10	CBN100	CBN150	CBN170	CBN200	CBN300	CBN500	CBN600	CBN1010P	CBN060K	CBN160C	CBN300P	CBN400C				
RCCG	6.35S-02020-LF	■	■															TRAOR/L..6.35 TRDON..6.35	***

■ Stock standard
 Subject to change refer to current price- and stock-list
 ***For information, contact your local Seco office

Tip sizes, see page(s) 70
 Edge preparation, see page(s) 67

RNGN-LF

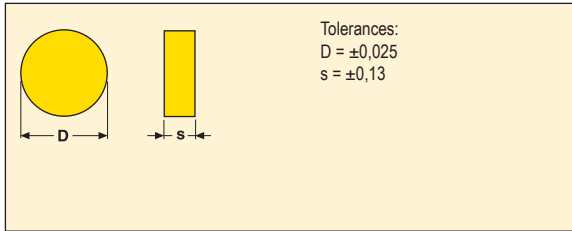

Size	Dimensions in mm	
	D	s
0603	6,350	3,18
0903	9,520	3,18
1204	12,700	4,76

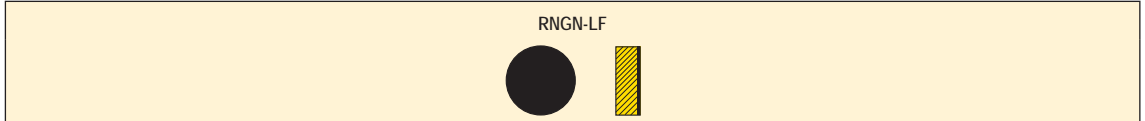

Inserts	Part No.	Grades												Toolholders			
		Uncoated						Coated						External	Internal		
		CBN010	CBN10	CBN100	CBN150	CBN170	CBN200	CBN300	CBN500	CBN600	CBN010P	CBN060K	CBN160C			CBN300P	CBN400C
RNGN-LF	RNGN 060300S-01525-LF				■									■		CRSNR/L..06	...CRSNR/L06
	060300S-02020-LF						■									CRDNN..06	
	RNGN 090300S-LF		■													CRSNR/L..09	...CRSNR/L09
	090300S-01525-LF				■										■	CRDNN..09	
	090300S-02020-LF	■					■										
RNGN 120400S-02020-LF						■									CRSNR/L..12*	***	

■ Stock standard
 Subject to change refer to current price- and stock-list
 ***For information, contact your local Seco office

Tip sizes, see page(s) 70
 Edge preparation, see page(s) 67
 *Shim 117.10-621 for insert RN.N1204.., to be ordered separately

RNGN

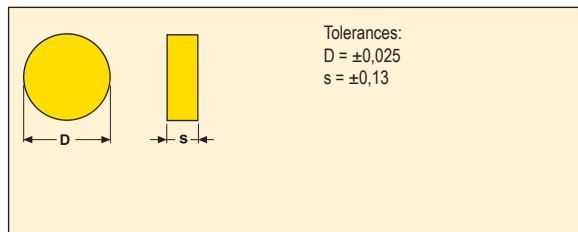

Size	Dimensions in mm	
	D	s
0603	6,35	3,18
0903	9,52	3,18
1203	12,70	3,18

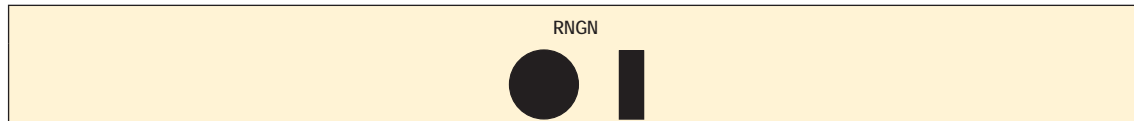

Inserts	Part No.	Grades													Toolholders				
		Uncoated						Coated							External	Internal			
		CBN010	CBN10	CBN100	CBN150	CBN170	CBN200	CBN300	CBN500	CBN600	CBN1010P	CBN0600K	CBN160C	CBN300P			CBN400C		
RNGN	RNGN 060300E	■		■														CRSNR/L..06	..-CRSNR/L06
	RNGN 060300S							■											
	060300S-01020	■																	
	060300S-01525												■						
	RNGN 090300E25						■											CRSNR/L..09	..-CRSNR/L09
	RNGN 090300S								■										
	090300S-01020	■																	
	090300S-01525																	■	
	RNGN 120300S-01020	■		■														CRSNR/L..12	***

■ Stock standard
Subject to change refer to current price- and stock-list
***For information, contact your local Seco office

Tip sizes, see page(s) 70
Edge preparation, see page(s) 67

RNMN

Tolerances:
 D = ±0,05
 D = ±0,08
 D = ±0,10
 D = ±0,13
 s = ±0,13

Size:
 06, 09
 12
 19
 25

Size	Dimensions in mm	
	D	s
0603	6,35	3,18
0903	9,52	3,18
1203	12,70	3,18
1204	12,70	4,76
1904	19,05	4,76

RNMN

Inserts	Part No.	Grades												Toolholders				
		Uncoated						Coated						External	Internal			
		CBN010	CBN10	CBN100	CBN150	CBN170	CBN200	CBN300	CBN500	CBN600	CBN010P	CBN060K	CBN160C			CBN300P	CBN400C	
RNMN	RNMN 060300S 060300S-02020P						■			■							CRSNR/L..06 CRDNN..06	...CRSNR/L06
RNMN	RNMN 090300E						■									■	CRSNR/L..09 CRDNN..09	...CRSNR/L09
RNMN	RNMN 090300S 090300S-02020 090300S-02020P						■			■						■		
RNMN	RNMN 120300E						■									■	CRSNR/L..12* CRDNN..12*	***
RNMN	RNMN 120300S 120300S-02020 120300S-02020P						■			■						■		
RNMN	RNMN 120400S 120400S-02020						■			■						■		
RNMN	RNMN 120400S-02020P									■								
RNMN	RNMN 120400S-04015 120400S-04015P 120400S25-07015P						■	■			■					■		
RNMN	RNMN 120400X-05015									■								
RNMN	RNMN 190400S-10020									■							***	***

■ Stock standard
 Subject to change refer to current price- and stock-list
 ***For information, contact your local Seco office

Tip sizes, see page(s) 70
 Edge preparation, see page(s) 67
 *Shim 117.10-621 for insert RNMN1204.. to be ordered separately

SCGW

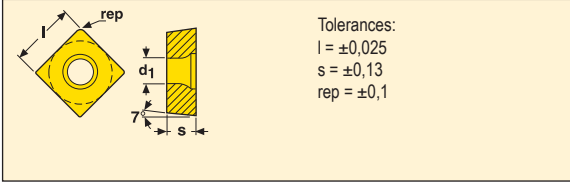

Size	Dimensions in mm			
	l	s	d ₁	rep
0602	6,350	2,38	2,9	0,8
09T3	9,525	3,97	4,5	0,4-0,8

SCGW



Inserts	Part No.	Grades												Toolholders			
		Uncoated						Coated						External	Internal		
		CBN010	CBN10	CBN100	CBN150	CBN170	CBN200	CBN300	CBN500	CBN600	CBN101P	CBN060K	CBN160C			CBN300P	CBN400C
SCGW	SCGW 060208S-01020-LF						■									***	***
	SCGW 09T304S-01020-LF						■									SSDCN..09	SSKCR/L..09
	09T308S-01020-LF						■										

SCMN

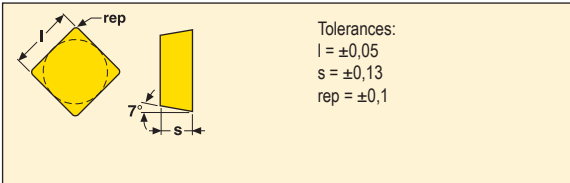

Size	Dimensions in mm		
	l	s	rep
0904	9,53	4,76	0,8

SCMN



Inserts	Part No.	Grades												Toolholders			
		Uncoated						Coated						External	Internal		
		CBN010	CBN10	CBN100	CBN150	CBN170	CBN200	CBN300	CBN500	CBN600	CBN101P	CBN060K	CBN160C			CBN300P	CBN400C
SCMN	SCMN 090408S-WZ-85						■									***	***

■ Stock standard
 Subject to change refer to current price- and stock-list
 ***For information, contact your local Seco office

Tip sizes, see page(s) 70
 Edge preparation, see page(s) 67

SNGA

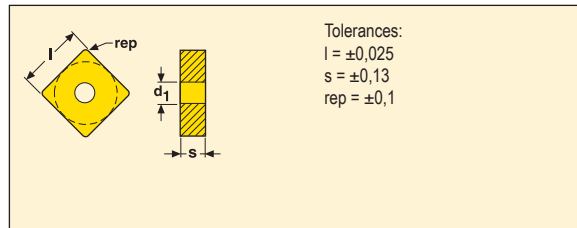

Tolerances:
 l = ±0,025
 s = ±0,13
 rep = ±0,1

Size	Dimensions in mm			
	l	s	d ₁	rep
1204	12,700	4,76	5,15	0,8

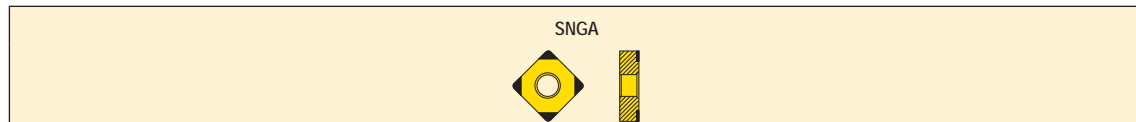

Inserts	Part No.	Grades													Toolholders				
		Uncoated						Coated							External	Internal			
		CBN010	CBN10	CBN100	CBN150	CBN170	CBN200	CBN300	CBN500	CBN600	CBN010P	CBN060K	CBN160C	CBN300P			CBN400C		
SNGA	SNGA 120408S-02020-L1-D						■											DSBNR/L..12-C DSSNR/L..12-C DSBNR/L..12 DSSNR/L..12 DSDNN..12 DSKNR/L..12 PSBNR/L..12 PSSNR/L..12 PSDNN..12 PSKNR/L..12	..-MSKNR/L12 ..-PSKNR/L12

■ Stock standard
 Subject to change refer to current price- and stock-list
 ***For information, contact your local Seco office

Tip sizes, see page(s) 70
 Edge preparation, see page(s) 67

SNGF

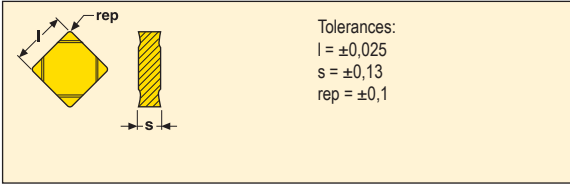

Size	Dimensions in mm		
	l	s	rep
0903	9,525	3,18	0,8-1,2

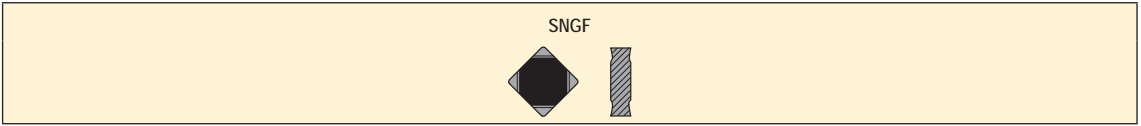

Inserts	Part No.	Grades														Toolholders			
		Uncoated							Coated							External	Internal		
		CBN010	CBN10	CBN100	CBN150	CBN170	CBN200	CBN300	CBN500	CBN600	CBN010P	CBN060K	CBN160C	CBN300P	CBN400C				
SNGF	SNGF 090308E																	***	***
	090312E																		

SNGN-LF

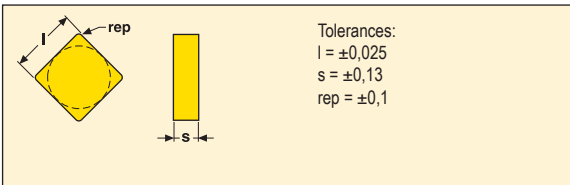

Size	Dimensions in mm		
	l	s	rep
1204	12,700	4,76	0,8

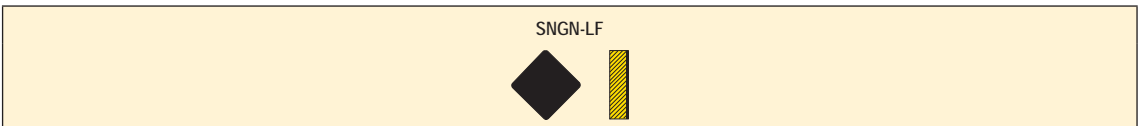

Inserts	Part No.	Grades														Toolholders			
		Uncoated							Coated							External	Internal		
		CBN010	CBN10	CBN100	CBN150	CBN170	CBN200	CBN300	CBN500	CBN600	CBN010P	CBN060K	CBN160C	CBN300P	CBN400C				
SNGN-LF	SNGN 120408S-02020-LF																	CSBNR/L..12 CSRNR/L..12 CSDNN..12 CSKNR/L..12	..-MSKNR/L12 (without pin)

■ Stock standard
 Subject to change refer to current price- and stock-list
 ***For information, contact your local Seco office

Tip sizes, see page(s) 70
 Edge preparation, see page(s) 67

SNGN

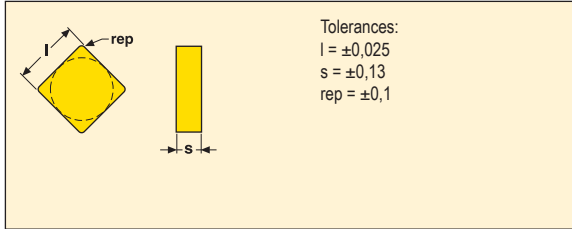

Size	Dimensions in mm		
	l	s	rep
0603	6,350	3,18	0,8
0903	9,525	3,18	0,8-1,6

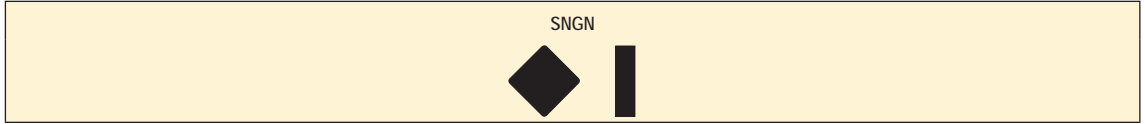

Inserts	Part No.	Grades												Toolholders			
		Uncoated						Coated						External	Internal		
		CBN010	CBN10	CBN100	CBN150	CBN170	CBN200	CBN300	CBN500	CBN600	CBN010P	CBN060K	CBN160C			CBN300P	CBN400C
SNGN	SNGN 060308S-01020	■														CSSNR/L...06 CSRNR/L...06 CSKNR/L...06	***
	SNGN 090308E						■									CSBNR/L...09 CSDNN...09	...CSKNR/L09
	SNGN 090308S						■										
	090308S-01020	■															
	090312S						■										
	090312S-01020	■	■														
	090316S						■										

■ Stock standard
 Subject to change refer to current price- and stock-list
 ***For information, contact your local Seco office

Tip sizes, see page(s) 70
 Edge preparation, see page(s) 67

SNMA

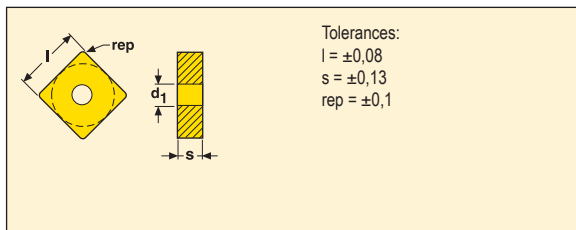

Size	Dimensions in mm			
	l	s	d ₁	rep
1204	12,70	4,76	5,15	1,6

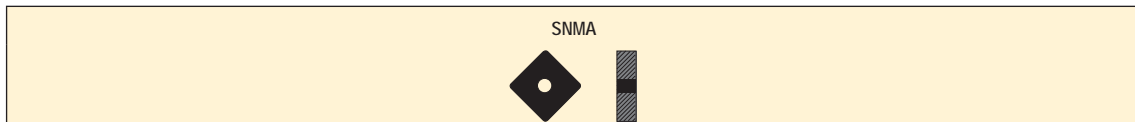

Inserts	Part No.	Grades												Toolholders			
		Uncoated						Coated						External	Internal		
		CBN010	CBN10	CBN100	CBN150	CBN170	CBN200	CBN300	CBN500	CBN600	CBN010P	CBN060K	CBN160C			CBN300P	CBN400C
SNMA	SNMA 120416S						■									DSBNR/L...12-C	..MSKNR/L12
																DSSNR/L...12-C	..PSKNR/L12

■ Stock standard
 Subject to change refer to current price- and stock-list
 ***For information, contact your local Seco office

Tip sizes, see page(s) 70
 Edge preparation, see page(s) 67

SNMN

Tolerances:
 $l = \pm 0,05$
 $l = \pm 0,08$
 $s = \pm 0,13$
 $rep = \pm 0,1$

Size:
 06, 09
 12

Size	Dimensions in mm		
	l	s	rep
0603	6,350	3,18	0,8
0903	9,525	3,18	0,8-1,6
0904	9,525	4,76	1,6
1203	12,700	3,18	1,2
1204	12,700	4,76	0,8-1,6

SNMN

Inserts	Part No.	Grades												Toolholders		
		Uncoated						Coated						External	Internal	
		CBN010	CBN10	CBN100	CBN150	CBN170	CBN200	CBN300	CBN500	CBN600	CBN010P	CBN060K	CBN160C			CBN300P
SNMN	060308E						■							■	CSBNR/L..06 CSRNR/L..06 CSKNR/L..06	***
	060308S						■									
	090308E						■						■	■	CSBNR/L..09 CSDNN..09	...CSKNR/L09
	090312E						■						■			
	090308S						■						■			
	090308S-02020						■						■	■		
	090312S						■						■			
	090312S-02020P						■		■							
	090316S						■									
	090308S-WZ						■								CSBNR/L..09	...CSKNR/L09
	090308S-WZ-85						■								***	***
	090416S						■									
	120312S						■								CSBNR/L..12* CSRNR/L..12* CSDNN..12* CSKNR/L..12*	...MSKNR/L12 (SNMM1204..) (without pin)
	120412S						■									
	120412S-02020						■						■			
	120416S						■						■			
	120416S-02020						■		■							
	120416S-02020P						■		■							
	120416S-04015						■									
	120408S-WZ-85						■								***	***
	120408S-02020-WZ85						■		■				■			

■ Stock standard
 Subject to change refer to current price- and stock-list
 ***For information, contact your local Seco office

Tip sizes, see page(s) 70
 Edge preparation, see page(s) 67
 *Shim 174.10-622 for insert SNMN1203.., to be ordered separately

SPGW

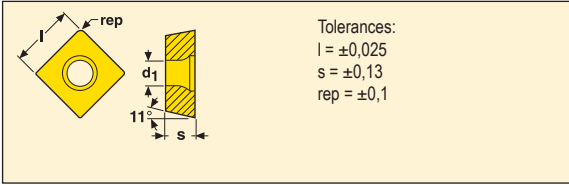

Size	Dimensions in mm			
	l	s	d ₁	rep
0503	5,560	3,18	2,6	0,2
0603	6,350	3,18	2,9	0,2

SPGW



Inserts	Part No.	Grades												Toolholders				
		Uncoated						Coated						External	Internal			
		CBN010	CBN10	CBN100	CBN150	CBN170	CBN200	CBN300	CBN500	CBN600	CBN010P	CBN060K	CBN160C			CBN300P	CBN400C	
SPGW	SPGW 050302S-01020-LF						■										***	***
	SPGW 060302S-01020-LF						■											

TCGN

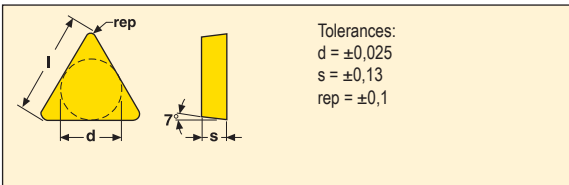

Size	Dimensions in mm			
	d	l	s	rep
0601	3,960	5,50	1,59	0,4

TCGN



Inserts	Part No.	Grades												Toolholders				
		Uncoated						Coated						External	Internal			
		CBN010	CBN10	CBN100	CBN150	CBN170	CBN200	CBN300	CBN500	CBN600	CBN010P	CBN060K	CBN160C			CBN300P	CBN400C	
TCGN	TCGN 060104E-LF	■															CTLCR/L..06	***

■ Stock standard
 Subject to change refer to current price- and stock-list
 ***For information, contact your local Seco office

Tip sizes, see page(s) 70
 Edge preparation, see page(s) 67

TCGW

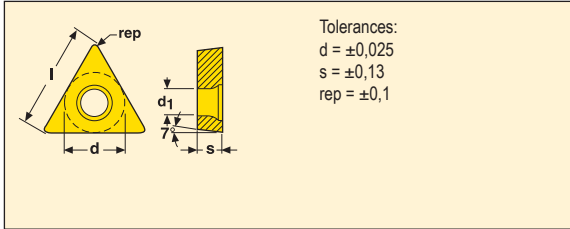

Size	Dimensions in mm				
	d	l	s	d ₁	rep
0902	5,560	9,00	2,38	2,6	0,4-0,8
1102	6,350	11,00	2,38	2,9	0,4-0,8



Inserts	Part No.	Grades												Toolholders				
		Uncoated						Coated						External	Internal			
		CBN010	CBN10	CBN100	CBN150	CBN170	CBN200	CBN300	CBN500	CBN600	CBN010P	CBN060K	CBN160C			CBN300P	CBN400C	
TCGW	TCGW 090204S-01020-LF	■	■				■										***	***
	090208S-01020-LF						■											
	TCGW 110204E-L1-C	■										■					STJCR/L...11	...STFCR/L11
	110208E-L1-C	■															STGCR/L...11	
	TCGW 110204S-01020-L1-C	■																
	110204S-01525-L1-C											■						
	110204S-02020-L1-C						■											
	110208S-01020-L1-C	■																
	110208S-01525-L1-C											■	■					
	110208S-02020-L1-C						■											
	TCGW 110204S-01020-LF						■											
	110208S-01020-LF						■											

■ Stock standard
 Subject to change refer to current price- and stock-list
 ***For information, contact your local Seco office

Tip sizes, see page(s) 70
 Edge preparation, see page(s) 67

TNGA

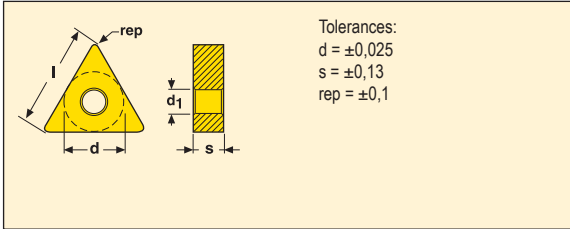

Size	Dimensions in mm				
	d	l	s	d ₁	rep
1604	9,525	16,50	4,76	3,81	0,4-1,2



Inserts	Part No.	Grades													Toolholders				
		Uncoated						Coated							External	Internal			
		CBN010	CBN10	CBN100	CBN150	CBN170	CBN200	CBN300	CBN500	CBN600	CBN1010P	CBN060K	CBN160C	CBN300P			CBN400C		
TNGA	TNGA 160404S-L0-C		■															DTGNR/L..16 DTNNR/L..16 DTTNR/L..16 DTFNR/L..16 PTBNR/L..16 PTGNR/L..16 PTJNR/L..16	..-PTFNR/L16 ..-MTFNR/L16
	TNGA 160404S-01020-L1-C	■																	
	160408S-01020-L1-C	■																	
	160408S-01525-L1-C				■								■						
	160408S-02020-L1-C						■												
	160412S-01525-L1-C																■		
	TNGA 160408S-01525-L1-V																		

■ Stock standard
 Subject to change refer to current price- and stock-list
 ***For information, contact your local Seco office

Tip sizes, see page(s) 70
 Edge preparation, see page(s) 67

TNGN-LF

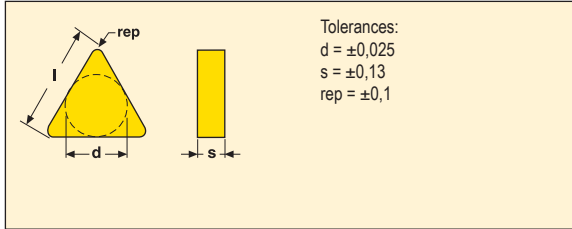

Size	Dimensions in mm			
	d	l	s	rep
1103	6,350	11,0	3,18	0,4-1,2

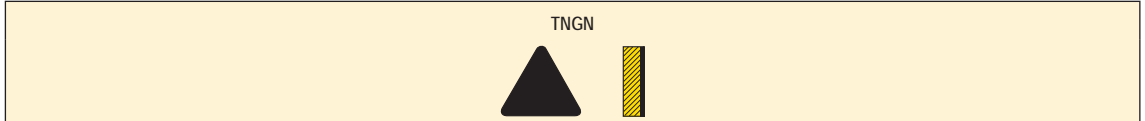

Inserts	Part No.	Grades												Toolholders			
		Uncoated						Coated						External	Internal		
		CBN010	CBN10	CBN100	CBN150	CBN170	CBN200	CBN300	CBN500	CBN600	CBN010P	CBN060K	CBN160C			CBN300P	CBN400C
TNGN	110308S-01525-LF				■									■		CTJNR/L..11 CTFNR/L..11	...CTUNR/L11
	110312S-01525-LF				■									■			
	110312S-02020-LF					■											
	TNGN 110304S25-02020-LF						■										

■ Stock standard
 Subject to change refer to current price- and stock-list
 ***For information, contact your local Seco office

Tip sizes, see page(s) 70
 Edge preparation, see page(s) 67

TNGN

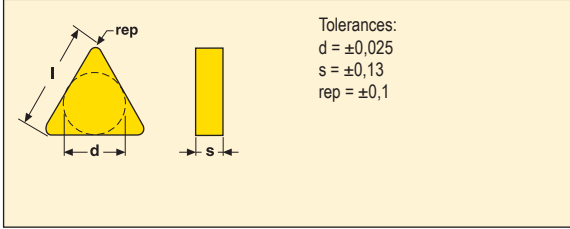

Size	Dimensions in mm			
	d	l	s	rep
1103	6,350	11,0	3,18	0,4-1,2
1603	9,525	16,5	3,18	0,4



Inserts	Part No.	Grades											Toolholders					
		Uncoated						Coated					External	Internal				
		CBN10	CBN10	CBN100	CBN150	CBN170	CBN200	CBN300	CBN500	CBN600	CBN1010P	CBN060K			CBN160C	CBN300P	CBN400C	
TNGN	TNGN 110304E	■		■										■			CTJNR/L..11 CTFNR/L..11 CTGNR/L..11-PL	..-CTUNR/L11
	TNGN 110308E25					■												
	TNGN 110304S-01020	■																
	110304S-01525														■			
	110308S-01020	■																
	110308S-01525																	
	110312S-01020	■																
	110312S-01525																	
	TNGN 160304S-01020	■															CTJNR/L..16* CTFNR/L..16* CTGNR/L..16-PL	***

■ Stock standard
Subject to change refer to current price- and stock-list
***For information, contact your local Seco office

Tip sizes, see page(s) 70
Edge preparation, see page(s) 67

*Shim UTN160412 for insert TNGN1603., to be ordered separately

TNMX

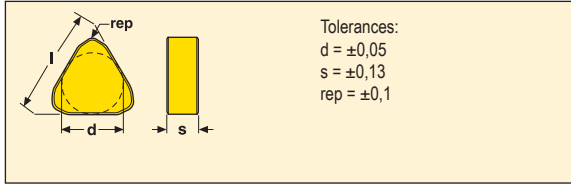

Size	Dimensions in mm			
	d	l	s	rep
1103	6,35	11,0	3,18	0,8

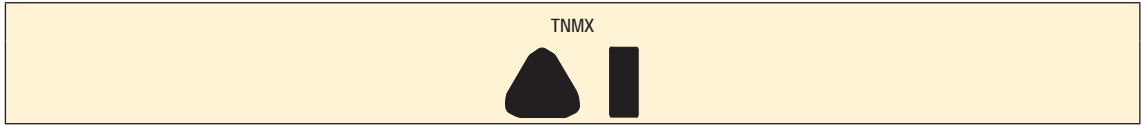

Inserts	Part No.	Grades												Toolholders			
		Uncoated						Coated						External	Internal		
		CBN010	CBN10	CBN100	CBN150	CBN170	CBN200	CBN300	CBN500	CBN600	CBN1010P	CBN060K	CBN160C			CBN300P	CBN400C
TNMX	TNMX 110308S-WZ							■								CTJNR/L..11*	CTUNR/L..11*

TPGN

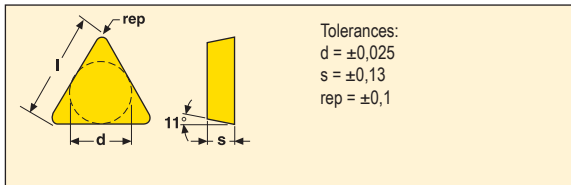

Size	Dimensions in mm			
	d	l	s	rep
1103	6,350	11,0	3,18	0,8

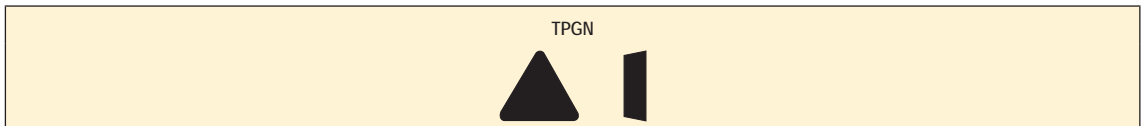

Inserts	Part No.	Grades												Toolholders			
		Uncoated						Coated						External	Internal		
		CBN010	CBN10	CBN100	CBN150	CBN170	CBN200	CBN300	CBN500	CBN600	CBN1010P	CBN060K	CBN160C			CBN300P	CBN400C
TPGN	TPGN 110308E	■														***	***
	TPGN 110308S-01020	■	■														

■ Stock standard
 Subject to change refer to current price- and stock-list
 ***For information, contact your local Seco office

Tip sizes, see page(s) 70
 Edge preparation, see page(s) 67

VNGA

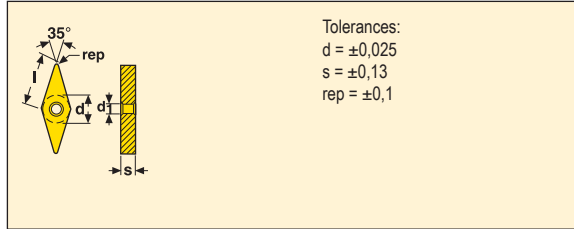

Size	Dimensions in mm				
	d	l	s	d ₁	rep
1604	9,525	16,00	4,76	3,81	0,2-0,8

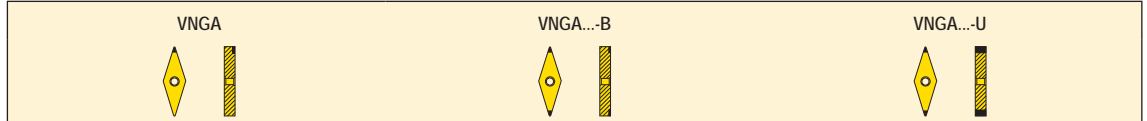

Inserts	Part No.	Grades													Toolholders			
		Uncoated						Coated							External	Internal		
		CBN010	CBN10	CBN100	CBN150	CBN170	CBN200	CBN300	CBN500	CBN600	CBN010P	CBN060K	CBN160C	CBN300P			CBN400C	
VNGA	VNGA 160402S-L0		■														CVVNN..16	...MVPNR/L16
	VNGA 160402S-01020-L1-B	■															DVJNR/L..16	...MVLNR/L16
	160402S-01525-L1-B																MVJNR/L..16	...MVYNR/L16
	160404S-01020-L1-B	■															MVPNR/L..16	
	160404S-01525-L1-B				■													
	160404S-02020-L1-B						■											
	160408S-01020-L1-B	■																
	160408S-01525-L1-B				■													
	160408S-02020-L1-B						■											
	VNGA 160404S-01525-L1-U																	
	160408S-01525-L1-U																	
	VNGA 160408S25-02020-L1B																	
	VNGA 160408S-L2																	
	160408S-02020-L2	■	■															

■ Stock standard
 Subject to change refer to current price- and stock-list
 ***For information, contact your local Seco office

Tip sizes, see page(s) 70
 Edge preparation, see page(s) 67

WNGA

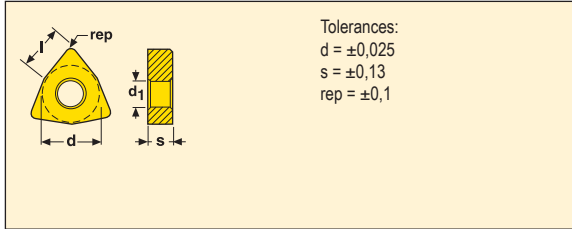

Size	Dimensions in mm				
	d	l	s	d ₁	rep
0604	9,525	6,6	4,76	3,81	0,8
0804	12,700	8,7	4,76	5,15	0,8-1,2

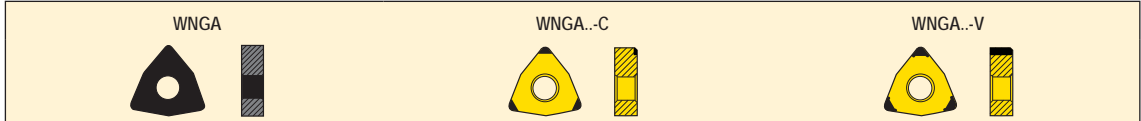

Inserts	Part No.	Grades												Toolholders						
		Uncoated						Coated						External	Internal					
		CBN010	CBN10	CBN100	CBN150	CBN170	CBN200	CBN300	CBN500	CBN600	CBN010P	CBN060K	CBN160C			CBN300P	CBN400C			
WNGA	WNGA 060408S-01525-WZ																DWLNRL..06-C	A..DWLNRL06-C		
	WNGA 060408S-02020-L1-C						■										DWLNRL..06-C DWLNRL..06 PWLNR/L..06	..DWLNRL06 ..PWLNR/L06		
	WNGA 060408S25-02020-L1C						■													
	WNGA 080408S-01020-L1-C 080408S-01525-L1-C	■															■	DWLNRL..08-C DWLNRL..08 PWLNR/L..08 MWLNRL..08	..DWLNRL08 ..PWLNR/L08 ..MWLNRL08	
	WNGA 080408S-01525-L1-V 080412S-01525-L1-V																■			
	WNGA 080408S-01020-L1WZC 080408S-01525L1WZC	■																■		
	WNGA 080408S-01525L1WZV 080412S-01525L1WZV																	■		

■ Stock standard
 Subject to change refer to current price- and stock-list
 ***For information, contact your local Seco office

Tip sizes, see page(s) 70
 Edge preparation, see page(s) 67

WNMA

Tolerances:
 $d = \pm 0,08$
 $s = \pm 0,13$
 $rep = \pm 0,1$

Size	Dimensions in mm				
	d	l	s	d ₁	rep
0604	9,52	6,6	4,76	3,81	0,8-1,6
0804	12,70	8,7	4,76	5,15	0,8-1,6

WNMA



Inserts	Part No.	Grades												Toolholders				
		Uncoated						Coated						External	Internal			
		CBN010	CBN10	CBN100	CBN150	CBN170	CBN200	CBN300	CBN500	CBN600	CBN010P	CBN060K	CBN160C			CBN300P	CBN400C	
WNMA	WNMA 060408S						■										DWLNRL...06-C	A..DWLNRL06-C
	060416S						■											
	WNMA 080408S						■										DWLNRL...08-C	A..DWLNRL08-C
	080416S						■											

■ Stock standard
 Subject to change refer to current price- and stock-list
 ***For information, contact your local Seco office

Tip sizes, see page(s) 70
 Edge preparation, see page(s) 67

CCGT

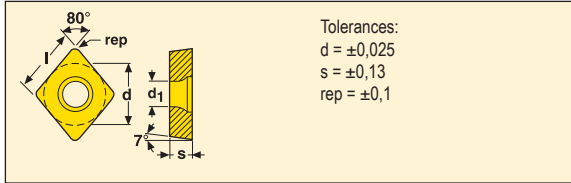

Size	Dimensions in mm				
	d	l	s	d ₁	rep
09T3	9,525	9,7	3,97	4,5	0,4

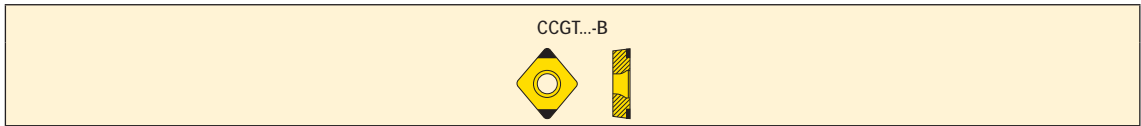

Inserts	Part No.	Grades												Toolholders		
		Uncoated						Coated						External	Internal	
		CBN010	CBN10	CBN100	CBN150	CBN170	CBN200	CBN300	CBN500	CBN10P	CBN060K	CBN160C	CBN300P			CBN400C
CCGT	CCGT 09T304S-01525-L1-B										■				SCLCR/L...09	...SCLCR/L09
	09T304S-01525L1WZB										■				SCECL...09	...SCLCR/L09
															SCGCR/L...09	...SCFCR/L09
															SCDCR/L...09	SCACL...09
															SCFCR/L...09	SCECL...09
															SCACR/L...09	...SCDCL09
															SCECL...09	
															SCLCR/L...09	

CNGM

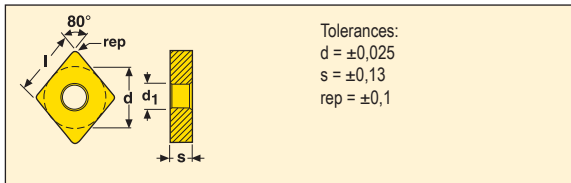

Size	Dimensions in mm				
	d	l	s	d ₁	rep
1204	12,700	12,9	4,76	5,15	0,8

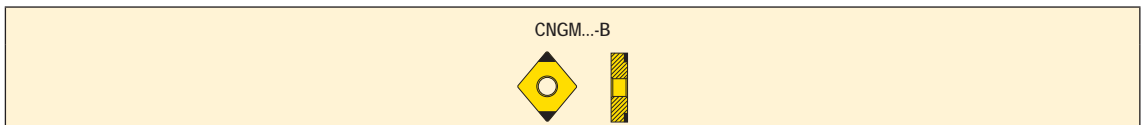

Inserts	Part No.	Grades												Toolholders		
		Uncoated						Coated						External	Internal	
		CBN010	CBN10	CBN100	CBN150	CBN170	CBN200	CBN300	CBN500	CBN10P	CBN060K	CBN160C	CBN300P			CBN400C
CNGM	CNGM 120408S-01525-L1-B										■				DCLNR/L...12	...PCLNR/L12
	120408S-01525L1WZB										■				PCLNR/L...12	...MCLNR/L12

■ Stock standard
 Subject to change refer to current price- and stock-list

Tip sizes, see page(s) 70
 Edge preparation, see page(s) 67
 Cutting data recommendations, see page(s) 68

CCMW

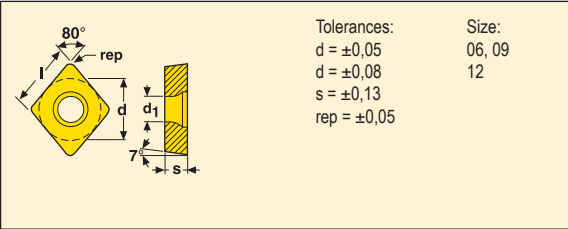

Size	Dimensions in mm				
	d	l	s	d ₁	rep
0602	6,35	6,5	2,38	2,9	0,2-0,8
09T3	9,52	9,7	3,97	4,5	0,2-0,8
1204	12,70	12,9	4,76	5,6	0,4-0,8

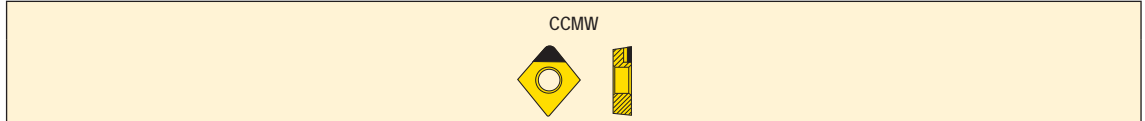

Inserts	Part No.	Grades					Toolholders	
		PCD20	PCD30	PCD30M			External	Internal
CCMW	CCMW 060202F-L1	■					SCLCR/L..06	..SCLCR/L06
	060204F-L1	■	■				SCGCR/L..06	..SCFCR/L06
	060208F-L1	■					SCDCR/L..06	SCACL..06
							SCFCR/L..06	SCECL..06
							SCACR/L..06	..SCDCL06
							SCECL..06	
	CCMW 060208F-L1-WZ	■					SCLCR/L..06	..SCLCR/L06
	CCMW 09T302F-L1	■					SCLCR/L..09	..SCLCR/L09
	09T304F-L1	■					SCGCR/L..09	..SCFCR/L09
	09T308F-L1	■					SCDCR/L..09	SCACL..09
							SCFCR/L..09	SCECL..09
							SCACR/L..09	..SCDCL09
							SCECL..09	
	CCMW 120404F-L1	■					SCLCR/L..12	..SCMCN12
120408F-L1	■							

■ Stock standard
 Subject to change refer to current price- and stock-list
 ***For information, contact your local Seco office

Tip sizes, see page(s) 70
 Edge preparation, see page(s) 67

DCMW

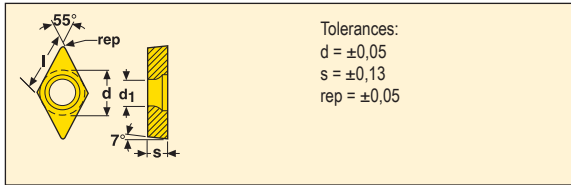

Size	Dimensions in mm				
	d	l	s	d ₁	rep
0702	6,35	7,8	2,38	2,9	0,2-0,4
11T3	9,52	11,6	3,97	4,5	0,2-0,4

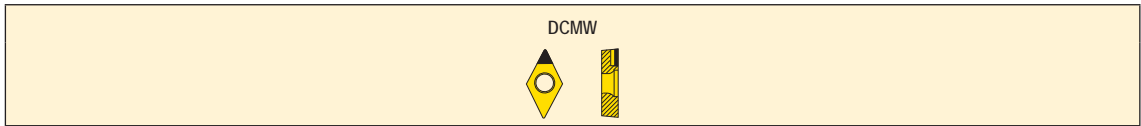

Inserts	Part No.	Grades					Toolholders	
		PCD20	PCD30	PCD30M			External	Internal
DCMW	DCMW 070202F-L1	■					SDHCR/L..07 SDJCR/L..07 SDNCN..07 SDACR/L..07	..SDQCR/L07 ..SDUCR/L07
	070204F-L1	■						
	DCMW 11T302F-L1	■					SDHCR/L..11 SDJCR/L..11 SDNCN..11 SDACR/L..11	..SDQCR/L11 ..SDUCR/L11
	11T304F-L1	■						

RCGN

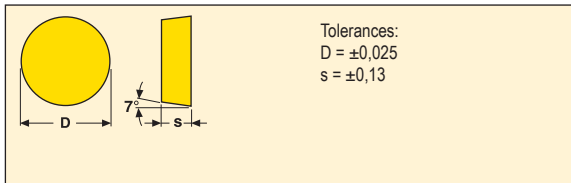

Size	Dimensions in mm	
	D	s
0903	9,52	3,18

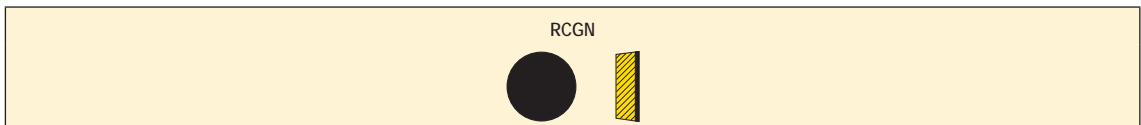

Inserts	Part No.	Grades					Toolholders	
		PCD20	PCD30	PCD30M			External	Internal
RCGN	RCGN 090300F-LF	■					***	***

■ Stock standard
 Subject to change refer to current price- and stock-list
 ***For information, contact your local Seco office

Tip sizes, see page(s) 70
 Edge preparation, see page(s) 67

RNGN

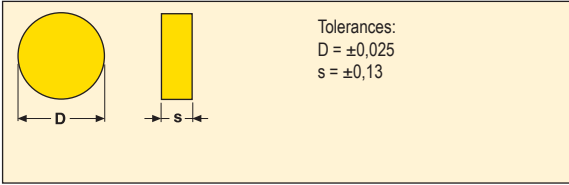

Size	Dimensions in mm	
	D	s
0603	6,35	3,18
0903	9,52	3,18
1203	12,70	3,18

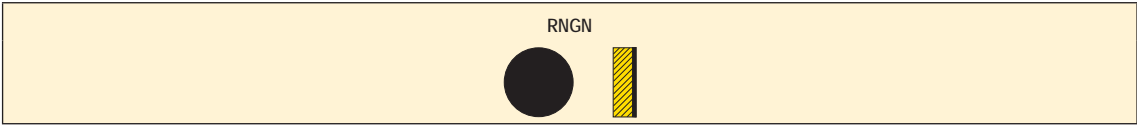

Inserts	Part No.	Grades				Toolholders	
		PCD20	PCD30	PCD30M	External	Internal	
RNGN	RNGN 060300F-LF			■	CRSNR/L..06	..-CRSNR/L06	
	RNGN 090300F-LF	■	■		CRSNR/L..09 CRDNN..09	..-CRSNR/L09	
	RNGN 120300F-LF	■			CRSNR/L..12 CRDNN..12	***	

TCMW

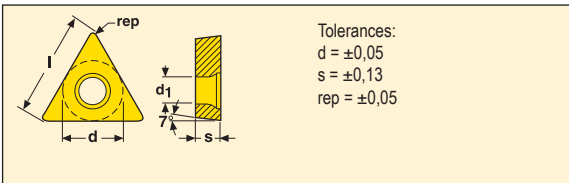

Size	Dimensions in mm				
	d	l	s	d ₁	rep
0902	5,56	9,0	2,38	2,5	0,4
1102	6,35	11,0	2,38	2,9	0,4
16T3	9,52	16,5	3,97	4,5	0,4

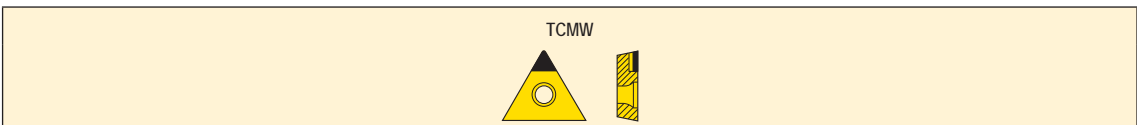

Inserts	Part No.	Grades				Toolholders	
		PCD20	PCD30	PCD30M	External	Internal	
TCMW	TCMW 090204F-L1	■			***	***	
	TCMW 110204F-L1	■			STJCR/L..11 STFCR/L..11 STGCR/L..11	..-STFCR/L11	
	TCMW 16T304F-L1	■			STFCR/L..16 STGCR/L..16	..-STFCR/L16	

■ Stock standard
Subject to change refer to current price- and stock-list
***For information, contact your local Seco office

Tip sizes, see page(s) 70
Edge preparation, see page(s) 67

TPGN

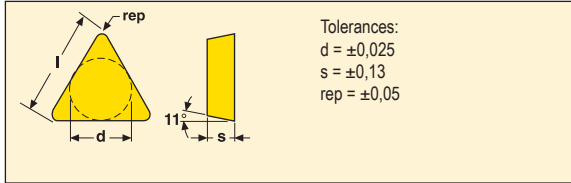

Size	Dimensions in mm			
	d	l	s	rep
1103	6,350	11,0	3,18	0,8
1603	9,525	16,5	3,18	0,2-0,8

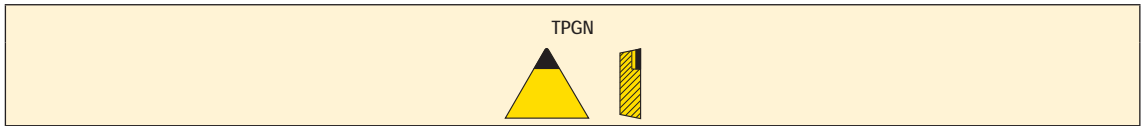

Inserts	Part No.	Grades				Toolholders	
		PCD20	PCD30	PCD30M	External	Internal	
TPGN	TPGN 110308F-L1	■			***	***	
	TPGN 160302F-L1	■			***	***	
	160304F-L1	■					
	160308F-L1	■					

VBMW

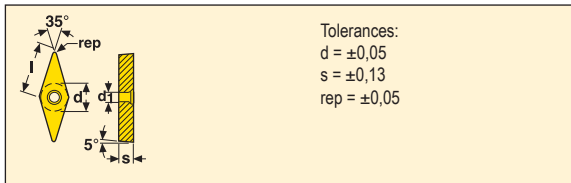

Size	Dimensions in mm				
	d	l	s	d ₁	rep
1604	9,52	16,0	4,76	4,5	0,2-0,4

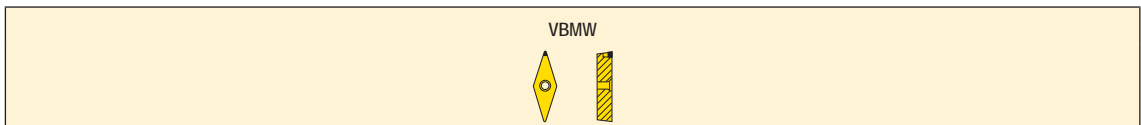

Inserts	Part No.	Grades				Toolholders	
		PCD20	PCD30	PCD30M	External	Internal	
VBWM	VBWM 160402F-L1	■			SVLBR/L..16 SVJBR/L..16	..SVQBR/L16 ..SVUBR/L16	
	160404F-L1	■			SVABR/L..16 SVVBN..16	..SVMBL16	

■ Stock standard
 Subject to change refer to current price- and stock-list
 ***For information, contact your local Seco office

Tip sizes, see page(s) 70
 Edge preparation, see page(s) 67

CNGN

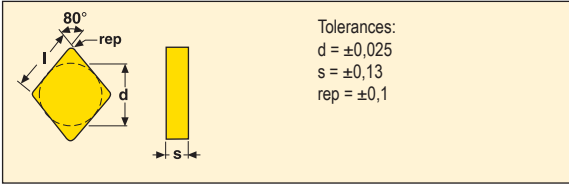

Size	Dimensions in mm			
	d	l	s	rep
1204	12,700	12,9	4,76	0,8
1207	12,700	12,9	7,94	0,8-1,2

CNGN



Inserts	Part No.	Grades	Toolholders	
		Uncoated	External	Internal
CNGN		CS100		
	CNGN 120408S-01020	■	CBBNR/L...12 CCLNR/L...12	..-MCLNR/L12 (without pin)
	CNGN 120708S-01020 120712S-01020	■ ■	***	***

RCGX

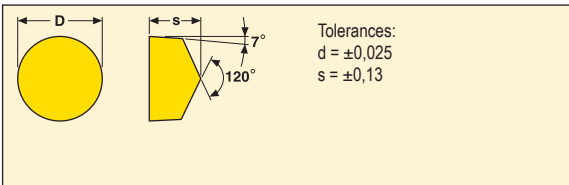

Size	Dimensions in mm	
	D	s
0606	6,350	6,35
0907	9,520	7,94
1207	12,700	7,94

RCGX



Inserts	Part No.	Grades	Toolholders	
		Uncoated	External	Internal
RCGX		CS100		
	RCGX 060600S-01020	■	***	***
	RCGX 090700S-01020	■		
	RCGX 120700S-01020	■		

■ Stock standard
 Subject to change refer to current price- and stock-list

*** For information, contact your local Seco office

RNGN

Tolerances:
 $d = \pm 0,025$
 $s = \pm 0,13$

Size	Dimensions in mm	
	D	s
1204	12,700	4,76
1207	12,700	7,94

RNGN

Inserts	Part No.	Grades	Toolholders	
		Uncoated	External	Internal
RNGN		CS100		
	RNGN 120400S-01020	■	CRSNR/L..12* CRDNN..12*	***
	RNGN 120700S-01020	■	***	***

*Shim 117.10-621 to be ordered separately

RPGX

Tolerances:
 $d = \pm 0,025$
 $s = \pm 0,13$

Size	Dimensions in mm	
	D	s
0907	9,525	7,94
1207	12,700	7,94

RPGX

Inserts	Part No.	Grades	Toolholders	
		Uncoated	External	Internal
RPGX		CS100		
	RPGX 090700S-01020	■	***	***
	RPGX 120700S-01020	■		

■ Stock standard
 Subject to change refer to current price- and stock-list

*** For information, contact your local Seco office



General information

The Seco MDT (Multi Directional Turning) system consists of holders and inserts for external radial, external axial and internal machining.

The system can be used for:

- Turning
- Profiling
- Grooving
- Parting-off
- Threading

Suitable applications are turning of parts with many different diameters, complicated profiles and grooves. For complex parts of this type several standard and special tools can be replaced by one Seco MDT tool. Savings can be achieved through fewer tool changes and reduced tool stock.

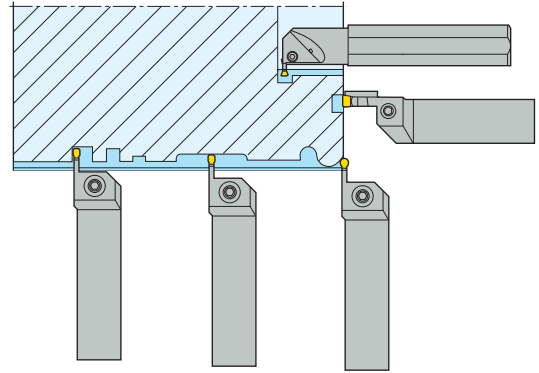

Seco MDT has a unique insert clamping method – Secoloc™.

A combination of V-shaped top clamp and serrated contact surfaces between the underside of the insert and the toolholder offers superb stability.

The relatively long insert also increases the stability.

The excellent stability gives a number of benefits

- Improved process safety
- Increased metal removal capacity/productivity
- Improved surface finish
- Reduced vibration risk
- Good repeatability ($\pm 0,03$ mm)

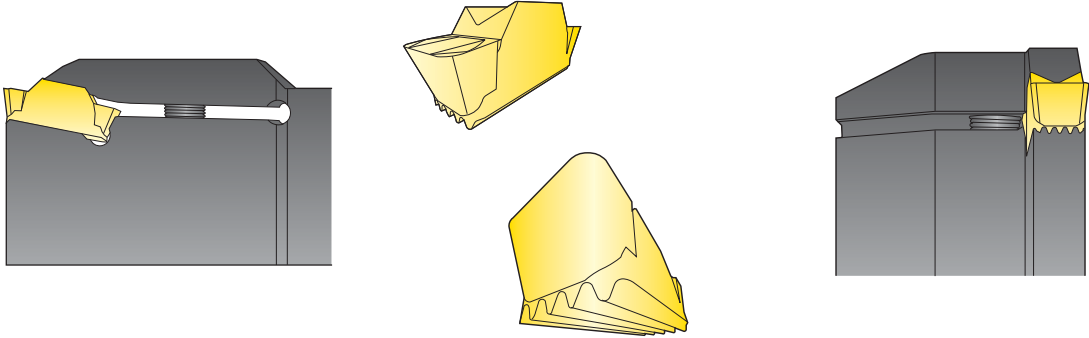

Seco Jetstream Tooling®

Seco Jetstream Tooling® holders feature a rake face coolant jet, that may provide even better chip control and significantly longer tool life. For more information on Jetstream Tooling® and accessories, please see page(s) 27-29 and 684.



External holders, Seco-Capto™



a_p				
8	JET	CFIR/L C6		
	non JET	CFIR/L C6		
6	JET	CFIR/L C5-C6	p. 489-490	CFMR/L C5-C6
	non JET	CFIR/L C5-C6	p. 533-534	
	modular	V21-CIR/L C4-C5-C6	p. 565	V21-CMR/L C4-C5-C6
5	JET	CFIR/L C4-C5-C6	p. 489-490	CFMR/L C5-C6
	non JET	CFIR/L C4-C5-C6	p. 533-534	
	modular	V21-CIR/L C4-C5-C6	p. 565	V21-CMR/L C4-C5-C6
4	JET	CFIR/L C4-C5-C6	p. 489-490	CFMR/L C4-C5-C6
	non JET	CFIR/L C4-C5-C6	p. 533-534	
	modular	V21-CIR/L C4-C5-C6	p. 565	V21-CMR/L C4-C5-C6
3	JET	CFIR/L C4-C5-C6	p. 489-490	CFMR/L C4-C5-C6
	non JET	CFIR/L C4-C5-C6	p. 533-534	
	modular	V21-CIR/L C4-C5-C6	p. 515	V21-CMR/L C4-C5-C6
2	JET	CFZR/L C4-C5-C6 *		
		$a_r = 9$	12	15
				18
				20

* Due to the design, grooving depth is limited to given \varnothing

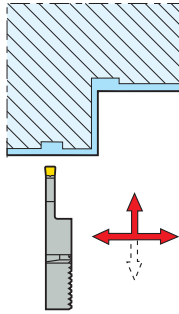

p. 490		CFOR/L C6		p. 494	
p. 534					
		p. 491-492		CFOR/L C5-C6	
		p. 493-494			
		p. 565			
p. 491-492		CFOR/L C4-C5-C6		p. 493-494	
		p. 565			
CFOR/L C4-C5-C6		p. 493-494			
		p. 495			
20	24	25	26	30	36
					48
					64
Ø52					

External holders

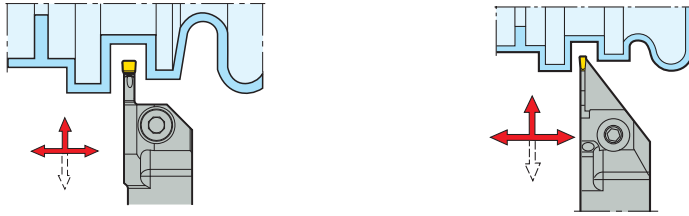

a_p					
8	JET	CFIR/L 25-32			
	non JET	CFIR/L 25-32			
6	JET	CFIR/L 20-25-32		p. 518	CFMR/L 25-32
	non JET	CFIR/L 20-25-32		p. 536	CFMR/L 20-25-32
	modular	V21-CIR/L 20-25-32		p. 565	V21-CMR/L 20-25-32
5	JET	CFIR/L 20-25-32		p. 517	CFMR/L 25-32
	non JET	CFIR/L 20-25-32		p. 536	CFMR/L 20-25-32
	modular	V21-CIR/L 20-25-32		p. 565	V21-CMR/L 20-25-32
4	JET	CFIR/L 20-25-32		p. 517	CFMR/L 20-25-32
	non JET	CFIR/L 12-16-20-25-32		p. 535	CFMR/L 20-25-32
	modular	V21-CIR/L 20-25-32		p. 535	V21-CMR/L 20-25-32
3	JET	CFIR/L 20-25-32		p. 517	CFMR/L C4-C5-C6
	non JET	CFIR/L 12-16-20-25-32		p. 535	CFMR/L 20-25-32
	modular	V21-CIR/L 20-25-32		p. 565	V21-CMR/L 20-25-32
2	JET	CFOR/L 12-16*		p. 520	CFSR/L 20*
	non JET	CFOR/L 12-16*		p. 540	CFSR/L 12-16*

$a_r = 9$	12	15	18	20
	$\varnothing 25,4$		$\varnothing 33$	$\varnothing 37$

* Due to the design, grooving depth is limited to given \varnothing

** CFTR/L 25-32 p. 539

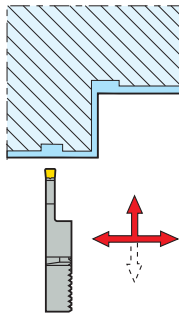

p. 518			
p. 536	CFMR/L 25-32	p. 538	CFSR/L 25-32 p. 541
		p. 519	
		p. 538	CFSR/L 25-32 p. 541
		p. 565	
	p. 519		
	p. 538	CFSR/L 25-32	p. 541
	p. 565		
CFPR/L 20-25*	p. 539	CFSR/L 25-32	p. 541
	p. 541**		
	p. 522		
	p. 542		
20	24 25 26	30 32	40 48 64
	∅50 ∅52		

Axial holders, Seco-Capto™



Ø of initial plunge INPLM- INPLX	a _p	All Seco-Capto™ axial holders are JET		
200-500	8	CFIR/L C6		
	6	CFOR/L C5-C6		
	5	CFOR/L C4-C5-C6		
	4	CFOR/L C4-C5-C6		
	3	CFOR/L C4-C5-C6	p. 503, 505, 507, 510, 512, 514	
140-230	8	CFIR/L C6		
	6	CFIR/L C5-C6		
	5	CFIR/L C4-C5-C6	p. 497, 499, 501	CFOR/L C4-C5-C6
	4	CFIR/L C4-C5-C6	p. 496, 498, 500	CFOR/L C4-C5-C6
	3	CFOR/L C4-C5-C6	p. 503, 505, 507, 510, 512, 514	
110-170	8	CFIR/L C6		
	6	CFIR/L C5-C6		
	5	CFIR/L C4-C5-C6	p. 497, 499, 501	CFOR/L C4-C5-C6
	4	CFIR/L C4-C5-C6	p. 496, 498, 500	CFPR/L C4-C5-C6
	3	CFIR/L C4-C5-C6	p. 496, 498, 500	CFOR/L C4-C5-C6
90-130	8	CFIR/L C6		
	6	CFIR/L C5-C6		
	5	CFIR/L C4-C5-C6	p. 497, 499, 501	CFOR/L C4-C5-C6
	4	CFIR/L C4-C5-C6	p. 496, 498, 500	CFOR/L C4-C5-C6
	3	CFIR/L C4-C5-C6	p. 496, 498, 500	CFOR/L C4-C5-C6
70-100	6	CFIR/L C5-C6		
	5	CFIR/L C4-C5-C6	p. 497, 499, 501	CFOR/L C4-C5-C6
	4	CFIR/L C4-C5-C6	p. 496, 498, 500	CFOR/L C4-C5-C6
	3	CFIR/L C4-C5-C6	p. 496, 498, 500	CFOR/L C4-C5-C6
	55-80	6	CFIR/L C5-C6	
5		CFIR/L C4-C5-C6	p. 497, 499, 501	CFOR/L C4-C5-C6
4		CFIR/L C4-C5-C6	p. 496, 498, 500	CFOR/L C4-C5-C6
3		CFIR/L C4-C5-C6	p. 496, 498, 500	CFOR/L C4-C5-C6

a_r = 9

12

15

18

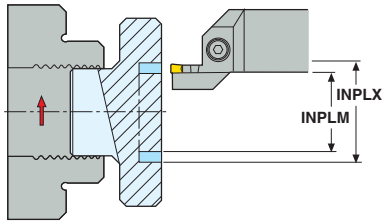

p. 502		CFOR/L C6	p. 509, 516
		p. 506, 508, 513, 515	
		p. 504, 506, 508, 511, 513, 515	
p. 503, 505, 507, 510, 512, 514			
p. 502		CFOR/L C6	p. 509, 516
CFOR/L C5-C6		p. 506, 508, 513, 515	
		p. 504, 506, 508, 511, 513, 515	
p. 503, 505, 507, 510, 512, 514			
p. 502		CFOR/L C6	p. 509, 516
CFOR/L C5-C6		p. 506, 508, 513, 515	
		p. 504, 506, 508, 511, 513, 515	
p. 503, 505, 507, 510, 512, 514			
p. 502		CFOR/L C6	p. 509, 516
CFOR/L C5-C6		p. 506, 508, 513, 515	
		p. 504, 506, 508, 511, 513, 515	
p. 503, 505, 507, 510, 512, 514			
CFOR/L C5-C6		p. 506, 508, 513, 515	
		p. 504, 506, 508, 511, 513, 515	
p. 503, 505, 507, 510, 512, 514			
CFOR/L C5-C6		p. 506, 508, 513, 515	
		p. 504, 506, 508, 511, 513, 515	
p. 503, 505, 507, 510, 512, 514			

Axial holders



Ø of initial plunge INPLM- INPLX	a _p			
200-500	8	CF(G)IR/L 32 / CFIR/L 32JET		
	6	CFOR/L 25JET		
	5	CFOR/L 25JET		
	4	CFOR/L 25JET		
	3	CFOR/L 25JET	p. 527, 530	
140-230	8	CF(G)IR/L 32 / CFIR/L 32JET		
	6	CF(G)IR/L 25 / CFIR/L 25JET		
	5	CF(G)IR/L 25 / CFIR/L 25JET	p. 525, 544, 547	CFOR/L 25JET
	4	CF(G)IR/L 25 / CFIR/L 25JET	p. 524, 543, 546	CFOR/L 25JET
	3	CFOR/L 25JET	p. 527, 530	
110-170	8	CF(G)IR/L 32 / CFIR/L 32JET		
	6	CF(G)IR/L 25 / CFIR/L 25JET		
	5	CF(G)IR/L 25 / CFIR/L 25JET	p. 525, 544, 547	CFOR/L 25JET
	4	CF(G)IR/L 25 / CFIR/L 25JET	p. 524, 543, 546	CFOR/L 25JET
	3	CF(G)IR/L 25 / CFIR/L 25JET	p. 524, 543, 546	CFOR/L 25JET
90-130	8	CF(G)IR/L 32 / CFIR/L 32JET		
	6	CF(G)IR/L 25 / CFIR/L 25JET		
	5	CF(G)IR/L 25 / CFIR/L 25JET	p. 525, 544, 547	CFOR/L 25JET
	4	CF(G)IR/L 25 / CFIR/L 25JET	p. 524, 543, 546	CFOR/L 25JET
	3	CF(G)IR/L 25 / CFIR/L 25JET	p. 524, 543, 546	CFOR/L 25JET
70-100	6	CF(G)IR/L 25 / CFIR/L 25JET		
	5	CF(G)IR/L 25 / CFIR/L 25JET	p. 525, 544, 547	CFOR/L 25JET
	4	CF(G)IR/L 25 / CFIR/L 25JET	p. 524, 543, 546	CFOR/L 25JET
	3	CF(G)IR/L 25 / CFIR/L 25JET	p. 524, 543, 546	CFOR/L 25JET
55-80	6	CFIR/L 25JET		
	5	CFIR/L 25JET	p. 523, 525	CFOR/L 25JET
	4	CFIR/L 25JET	p. 523, 524	CFOR/L 25JET
	3	CFIR/L 25JET	p. 523, 524	CFOR/L 25JET

a_r = 9

12

15

18

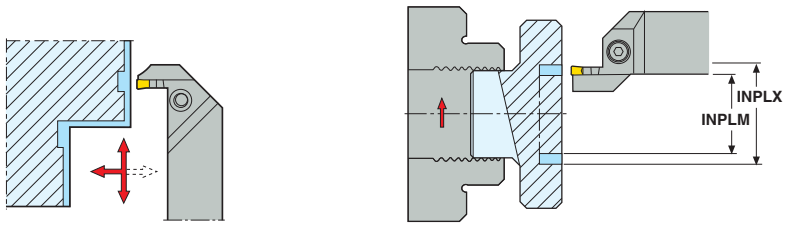

p. 526, 545, 548	CFOR/L 32JET	p. 529, 532
	p. 528, 531	
p. 527, 530		
p. 526, 545, 548	CFOR/L 32JET	p. 529, 532
CFOR/L 25JET	p. 528, 531	
	p. 528, 531	
p. 527, 530		
p. 526, 545, 548	CFOR/L 32JET	p. 529, 532
CFOR/L 25JET	p. 528, 531	
	p. 528, 531	
p. 527, 530		
p. 526, 545, 548	CFOR/L 32JET	p. 529, 532
CFOR/L 25JET	p. 528, 531	
	p. 528, 531	
p. 527, 530		
CFOR/L 25JET	p. 528, 531	
	p. 528, 531	
p. 527, 530		
CFOR/L 25JET	p. 528, 531	
	p. 528, 531	
p. 527, 530		

Internal holders

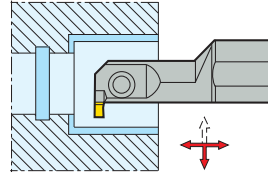
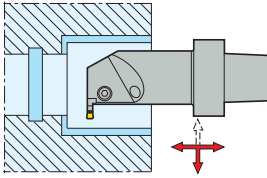

DCINN _{min}	a _p	Shank type		
45	6	Seco-Capto	CGGR/L C5-C6	
		Bar	CGGR/L Ø40	
	5	Seco-Capto	CGGR/L C4-C5-C6	
		Bar	CGGR/L Ø40	
	4	Seco-Capto	CGGR/L C4-C5-C6	
		Bar	CGGR/L Ø40*	
3	Seco-Capto	CGGR/L C4-C5-C6	p. 553-554	
	Bar	CGGR/L Ø40	p. 558	
32	6	Seco-Capto	CGFR/L C5-C6	
		Bar	CGFR/L Ø32	
	5	Seco-Capto	CGFR/L C4-C5-C6	
		Bar	CGFR/L Ø32	
	4	Seco-Capto	CGGR/L C4-C5-C6	
		Bar	CGGR/L Ø32	
3	Seco-Capto	CGIR/L C4-C5-C6		
	Bar	CGIR/L Ø32		
25	4	Seco-Capto	CGFR/L C5-C6	
		Bar	CGFR/L Ø25	
	3	Seco-Capto	CGHR/L C5-C6	
		Bar	CGHR/L Ø25	
2	Seco-Capto	CGJR/L C4-C5-C6		
	Bar	CGJR/L Ø25		
20	4	Seco-Capto	CGFR/L C4-C5-C6	p. 549-550
		Bar	CGFR/L Ø20	p. 556
	3	Seco-Capto	CGFR/L C4-C5-C6	p. 549-550
		Bar	CGFR/L Ø20	p. 556
2	Seco-Capto	CGHR/L C4-C5-C6	p. 555	
	Bar	CGHR/L Ø20	p. 559	
16	3	Seco-Capto	CGER/L C4-C5-C6	p. 549-550
		Bar	CGER/L Ø16	p. 556

a_r = 3

5,5

6

Internal holders

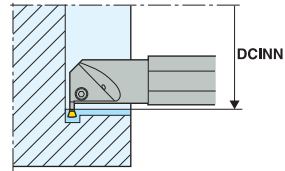
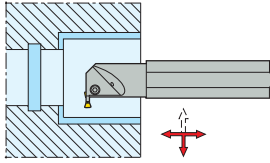

			p. 553-554
			p. 558
		p. 553-539	
		p. 558	
	p. 553, 554		
	p. 558		
		p. 551-552	
		p. 557	
		p. 551-552	
		p. 557	
	p. 551-552	CGHR/L C5-C6	p. 549-550
	p. 557	CGHR/L Ø32	p. 556
	p. 551-552	CGJR/L C5-C6	p. 549-550
	p. 557	CGJR/L Ø32	p. 556
	p. 549-550		
	p. 556		
	p. 549-550		
	p. 556		
	p. 555		
	p. 559		

6 7,5 8 9 10 10,5 12

Axial modular blades



INPLM-INPLX	a_p			
17-200	4	V21-CMR/L		p. 567, 569
26-100		V21-CIR/L	p. 567, 569	
17-34		V21-CHR/L	p. 567, 569	
17-200	3	V21-COR/L		p. 566, 568
33-76		V21-CKR/L	p. 566, 568	
17-39		V21-CJR/L	p. 566, 568	
			$a_r = 9,5$	11
				18
				20

Holders for modular blades



C4-C5-C6	p. 561	20-25-32	p. 562	C4-C5-C6 $\varnothing 25-32-40$	p. 563-564
----------	--------	----------	--------	---------------------------------	------------

External MTM holders

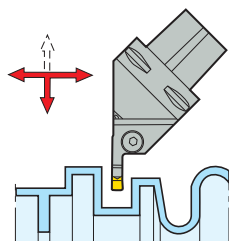

a_p					
8	JET	CDIR/L C6			p. 560
6	JET	CDIR/L C6		p. 560	
5	JET	CDIR/L C6		p. 560	
4	JET	CDIR/L C6		p. 560	
3	JET	CDIR/L C6	p. 560		

$a_r = 9$ 12 15 18 24

External toolholders

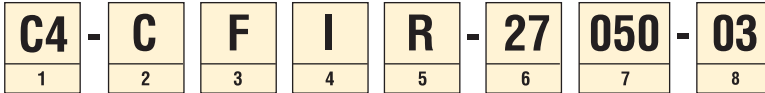
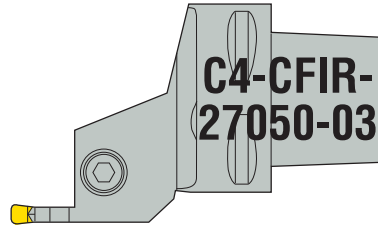

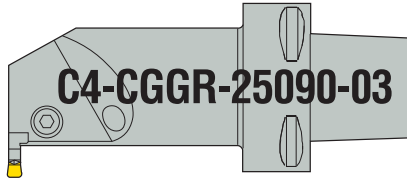

<p>1. Seco-Capto™ size</p> <p>C3 = 32 mm C4 = 40 mm C5 = 50 mm C6 = 63 mm</p> <p>D_{sm}</p>	<p>2. Insert clamping</p> <p>C</p> <p>Clamp</p>	<p>3. Toolholder setting angle</p> <p>90°</p> <p>0°</p> <p>α</p> <p>90°</p> <p>0°</p> <p>α</p> <p>α</p> <p>G = 0° R = 15° T = 30° S = 45° W = 60° K = 75° F = 90° B = 105° E = 120° D = 135°</p>
<p>4. Maximum grooving/turning depth</p> <p>a_p</p> <p>E = 1,0 x a_p F = 1,5 x a_p G = 2,0 x a_p H = 2,5 x a_p I = 3,0 x a_p J = 3,5 x a_p K = 4,0 x a_p</p> <p>L = 4,5 x a_p M = 5,0 x a_p N = 5,5 x a_p O = 6,0 x a_p S = 8,0 x a_p T = 8,5 x a_p Z = 12,5 x a_p</p> <p>X = Special</p>	<p>5. Version</p> <p>R</p> <p>L</p>	
<p>6. f_1-dimension</p> <p>f_1</p> <p>27 = 27 mm 35 = 35 mm 45 = 45 mm etc</p>	<p>7. l_1-dimension</p> <p>l_1</p> <p>050 = 50 mm 060 = 60 mm 065 = 65 mm etc</p>	<p>8. Seat size</p> <p>Seat size</p> <p>03 = 2,3 mm 04 = 3,1 mm 05 = 4,1 mm 06 = 5,1 mm 08 = 6,8 mm 2802 = 1,6 mm etc</p>

Internal toolholders

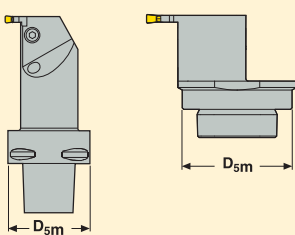
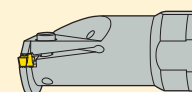
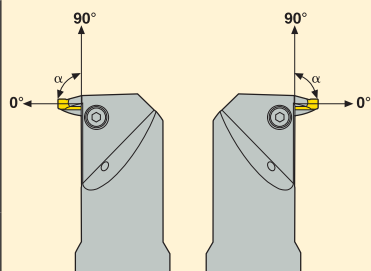

C4	-	C	G	G	R	-	25	090	-	03
1		2	3	4	5		6	7		8

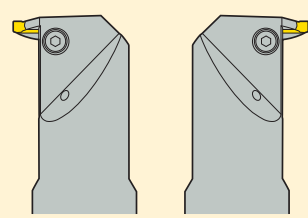
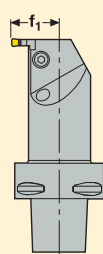
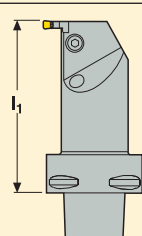
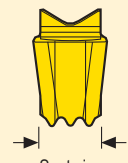
<p>1. Seco-Capto™ size</p>  <p>D_{sm}</p> <p>C3 = 32 mm C4 = 40 mm C5 = 50 mm C6 = 63 mm</p> <p>GL32 = 32 mm GL40 = 40 mm GL50 = 50 mm</p>	<p>2. Insert clamping</p> <p>C</p> 	<p>3. Toolholder setting angle</p>  <p>α</p> <p>G = 0° R = 15° T = 30° S = 45° W = 60° K = 75° F = 90° B = 105° E = 120° D = 135°</p>
<p>4. Maximum grooving/turning depth</p>  <p>a_p</p> <p>E = 1,0 x a_p F = 1,5 x a_p G = 2,0 x a_p H = 2,5 x a_p I = 3,0 x a_p J = 3,5 x a_p K = 4,0 x a_p</p> <p>L = 4,5 x a_p M = 5,0 x a_p N = 5,5 x a_p O = 6,0 x a_p S = 8,0 x a_p T = 8,5 x a_p Z = 12,5 x a_p</p> <p>X = Special</p>	<p>5. Version</p>  <p>R L</p>	<p>6. f_1-dimension</p>  <p>f_1</p> <p>12 = 12 mm 16 = 16 mm 20 = 20 mm etc</p>
<p>7. l_1-dimension</p>  <p>l_1</p> <p>065 = 65 mm 075 = 75 mm 080 = 80 mm etc</p>	<p>8. Seat size</p>  <p>Seat size</p> <p>1303 = 2,4 mm 1304 = 3,4 mm 03, 1603 = 2,3 mm 04, 1604 = 3,1 mm 05, 1605 = 4,1 mm 06, 1606 = 5,1 mm 1902 = 1,6 mm etc</p>	

External toolholders



C	F	Z	R	20	20	M	2802	RB	JET
1	2	3	4	5	6	7	8	12	13

C	F	I	R	25	25	M	04	L	100	070
1	2	3	4	5	6	7	8	9	10	11

1. Insert clamping

Clamp

2. Toolholder setting angle

α
 G = 0°
 R = 15°
 T = 30°
 S = 45°
 W = 60°
 K = 75°
 F = 90°
 B = 105°
 E = 120°
 D = 135°

3. Maximum grooving/turning depth

E = 1,0 x a_p	M = 5,0 x a_p
F = 1,5 x a_p	N = 5,5 x a_p
G = 2,0 x a_p	O = 6,0 x a_p
H = 2,5 x a_p	P = 6,25 x a_p
I = 3,0 x a_p	S = 8,0 x a_p
J = 3,5 x a_p	T = 8,5 x a_p
K = 4,0 x a_p	Z = 12,5 x a_p
L = 4,5 x a_p	X = Special

4. Version

R L

5. Shank height

12 = 12 mm
 16 = 16 mm
 20 = 20 mm
 etc

6. Shank width

12 = 12 mm
 16 = 16 mm
 20 = 20 mm
 etc

7. Tool length

H = 100 mm
 K = 125 mm
 M = 150 mm
 P = 170 mm
 R = 200 mm

8. Seat size

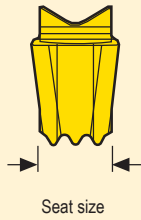

1303 = 2,4 mm
 1304 = 3,4 mm
 1603 = 2,3 mm
 1604 = 3,1 mm
 1605 = 4,1 mm
 1606 = 5,1 mm
 1902 = 1,6 mm
 2802 = 1,6 mm
 3008 = 6,8 mm
 etc

9. Tang curvature direction

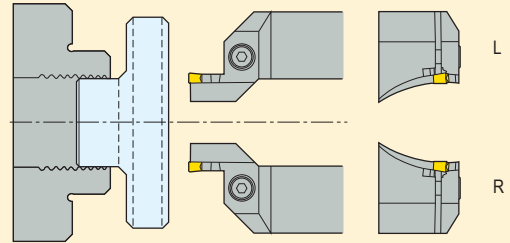

Additional information for axial machining

10. Maximum diameter

100 = 100 mm (D₁)

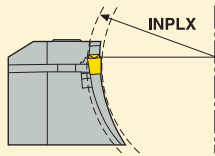

Additional information for axial machining

11. Minimum diameter

070 = 70 mm (D₂)

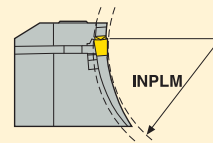

Additional information for axial machining

12. Holder modification

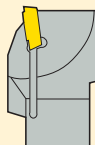

RB = Reinforced blade for specified diameter

13. Cooling system

JET = Jetstream Tooling®

Internal toolholders and GL heads



A	20	R	-	C	G	F	R	1303
1	2	3		4	5	6	7	8

<p>1. Toolholder type</p> <p>A = Steel with coolant passage</p> <p>S = Solid steel</p> <p>E = Solid carbide with brazed* cutting head and coolant passage</p> <p>*Brazed or equivalent</p>	<p>2. Shank diameter</p> <p>dm</p> <p>12 = 12 mm 20 = 20 mm 25 = 25 mm etc</p>
---	---

<p>3. Tool length</p> <p>l₁</p>	<p>K = 125 mm L = 140 mm M = 150 mm N = 160 mm P = 170 mm</p>	<p>Q = 180 mm R = 200 mm S = 250 mm T = 300 mm U = 350 mm</p>	<p>V = 400 mm</p>
---	---	---	-------------------

<p>4. Insert clamping</p> <p>C</p> <p>Clamp</p>	<p>5. Toolholder setting angle</p> <p>90°</p> <p>0°</p> <p>α</p> <p>α</p> <p>90°</p> <p>0°</p> <p>α</p> <p>α</p> <p>α</p> <p>G = 0° R = 15° T = 30° S = 45° W = 60° K = 75° F = 90° B = 105° E = 120° D = 135°</p>
--	---

<p>6. Maximum grooving/turning depth</p> <p>a_p</p> <p>E = 1,0 x a_p F = 1,5 x a_p G = 2,0 x a_p H = 2,5 x a_p I = 3,0 x a_p J = 3,5 x a_p K = 4,0 x a_p</p> <p>L = 4,5 x a_p M = 5,0 x a_p N = 5,5 x a_p O = 6,0 x a_p S = 8,0 x a_p T = 8,5 x a_p Z = 12,5 x a_p</p> <p>X = Special</p>	<p>7. Version</p> <p>R</p> <p>L</p>	<p>8. Seat size</p> <p>Seat size</p> <p>1303 = 2,4 mm 1304 = 3,4 mm 1603 = 2,3 mm 1604 = 3,1 mm 1605 = 4,1 mm 1606 = 5,1 mm 1902 = 1,6 mm 2802 = 1,6 mm</p>
--	--	--

Inserts

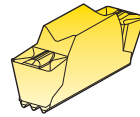
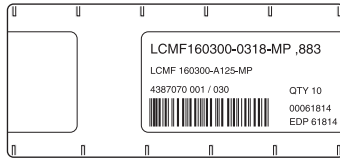

L	C	M	F	16	03	00	- 0318		- MP
1	2	3	4	5	6	7	8	9	10

1. Shape

L

Rectangular

2. Front clearance angle

$C = 7^\circ$

3. Tolerances

Tol.-class	Tolerance \pm mm				For insert width, a_p mm					
	a_p	d	rep	l	2	3	4	5	6	8
G	0,025	0,025	0,025	0,040		•	•	•	•	•
M	0,050	0,050	0,050	0,080	•	•	•	•	•	•

4. Insert type

R		Single ended with chipbreaker	N		Single ended without chipbreaker
F		Double ended with chipbreaker	A		Double ended without chipbreaker

5. Insert gauge length



6. Insert gauge width



Seat size

7. Corner radius



M0,00	= round	-A/G55	= thread profile
01	= 0,1 mm	-A/G60	= thread profile
02	= 0,2 mm	etc	
04	= 0,4 mm		
08	= 0,8 mm		

8. Insert width



0200	= 2,0 mm
0300	= 3,0 mm
0400	= 4,0 mm
0500	= 5,0 mm
	etc

9. Version

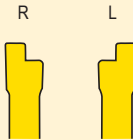

10. Insert type code (for further information, please see page(s) 463-464)

FT	= Chipbreaker for fine turning	FG	= For lock rings
FTR/L	= Right or left hand version with a specified setting angle, for parting-off	DY	= For dynamic O-rings
MT	= Chipbreaker for medium turning	ST	= For static O-rings
MG	= Chipbreaker for medium grooving	D76	= For thread undercuts
MC	= Chipbreaker for medium cut-off	R	= For radius
MCR/L	= Right or left hand version with a specified setting angle, for parting-off	A55/A60	= For threading
GG	= Chipbreaker for medium grooving	G55/G60	
GS	= Chipbreaker for fine grooving	ISO	
MP	= Chipbreaker for medium profiling		
RP	= Chipbreaker for fine and medium profiling		

CFIR/L – Basic choice

- For external turning, profiling and grooving
- Maximum working depth 3 x the insert width (can be limited by double ended inserts)
- Size 16 – For general machining
- Size 30 – For heavy machining

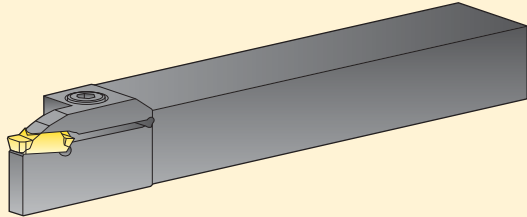
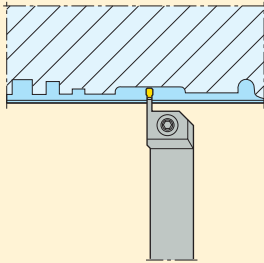

CFMR/L – Long reach

- For external turning, profiling and grooving
- Maximum working depth 5 x the insert width
- Single ended inserts should be used (CFMR/L, CFSR/L)
- Size 16 – For general machining
- Size 28 – For general machining
- Size 30 – For heavy machining

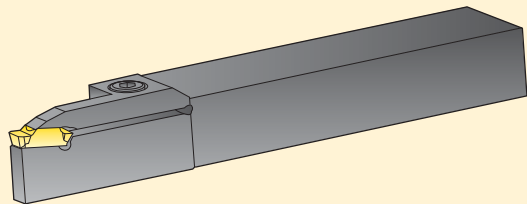
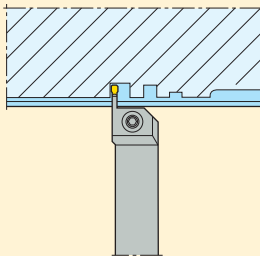

CFOR/L, CFPR/L, CFSR/L, CFTR/L, CFZR/L – Extra long reach, 6 x insert width up to 12,5 x insert width

- For grooving and parting-off
- Single ended inserts should be used (CFOR/L, CFPR/L, CFTR/L)
- Size 16 – For general machining
- Size 19 – For small part machining
- Size 28 – For general machining

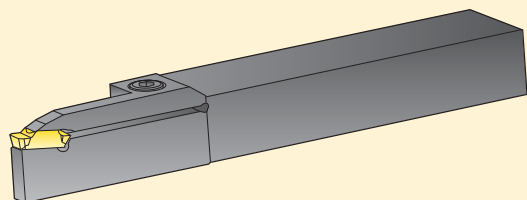
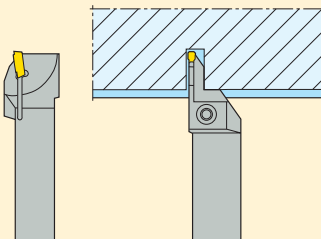

CGIR/L, CFIR/L, CFOR/L – Axial machining

- For axial turning, profiling and grooving
- Maximum working depth 3-6 x the insert width (can be limited by double ended inserts).
- These toolholders demand that the first cut must be made between two specified diameters (see code key)
- Size 16 – For general machining
- Size 30 – For heavy machining

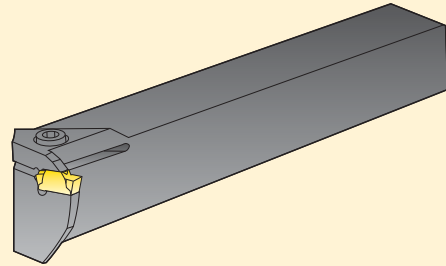

CGIR

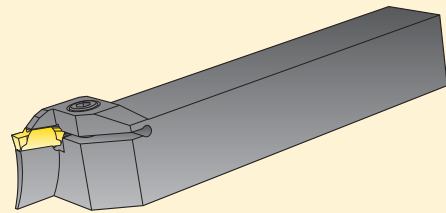
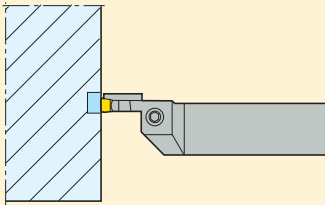

CFIL

CG.IR/L – Internal machining

- For internal turning, profiling and grooving
- Maximum working depth 1–3,5 x the insert width for size 13
- Maximum working depth 3 x the insert width for size 16
- Maximum working depth 2,5–3,5 x the insert width for size 19
- For through coolant supply
- Size 13 – For machining in small bore sizes
- Size 16 – For general machining
- Size 19 – For machining in small bore size

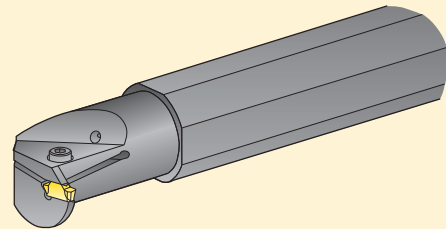

MDT16

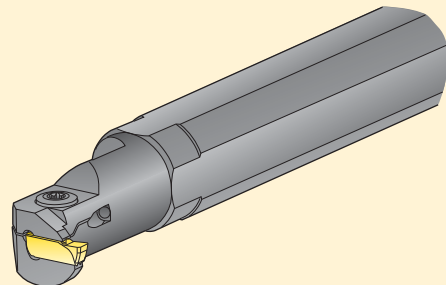
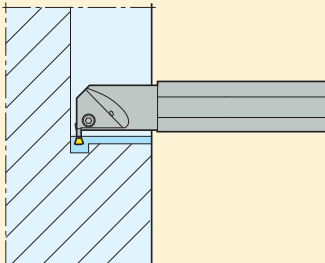

MDT13

Single ended blades

- Holder with both right and left hand blade mounting available
- Size 16 – For general machining

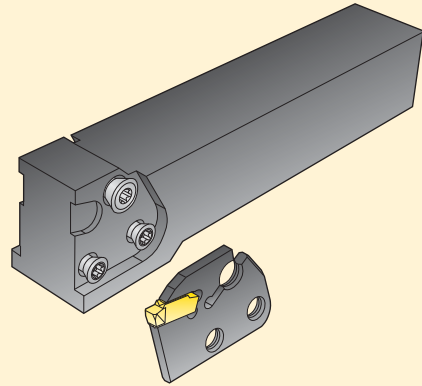
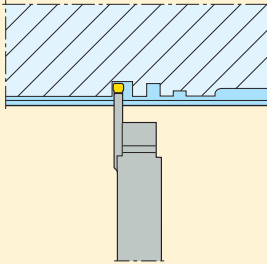

Double ended blades

- To be used in standard 150.10 toolblocks
- Size 16 – For parting-off

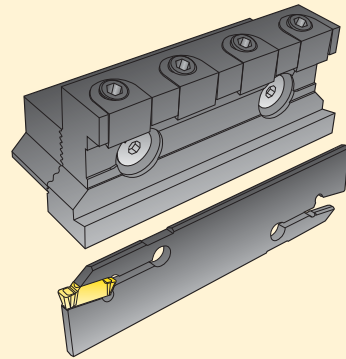
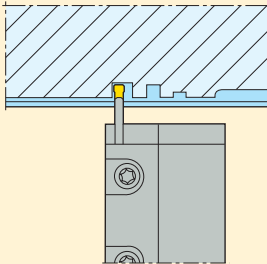

Modular holders, axial/radial

- For axial/radial turning, profiling and grooving
- Maximum working depth up to 6 x the insert width
- Axial toolholders demand that the first cut must be made between two specified diameters (see code key)
- Size 13 – For axia/radial machining at small diameters
- Size 16 – For axial/radial machining

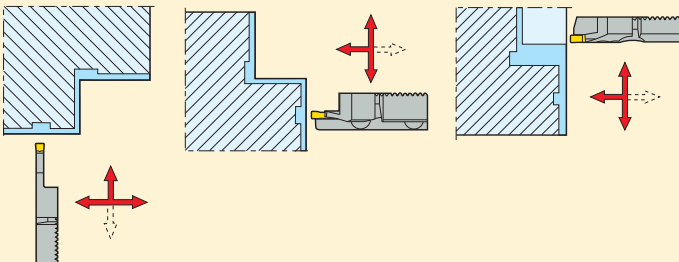
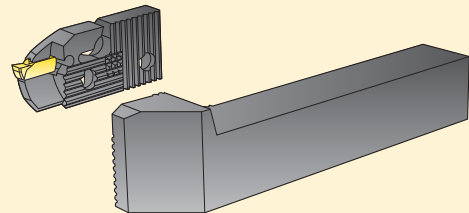

LCMF – Basic choice

- Double ended
- Economy (cutting edges at both ends)
- Size 13 – For machining in small bore sizes and axial machining at small diameters
- Size 16 – For general machining
- Size 19 – For small part machining
- Size 28 – For general machining
- Size 30 – For heavy machining

MDT13

MDT16
MDT30

MDT19
MDT28



LCMR

- Single ended
- Flexibility
- Reach (full length clearance)
- Size 13 – For machining in small bore sizes and axial machining at small diameters
- Size 16 – For general machining
- Size 30 – For heavy machining

MDT13

MDT16
MDT30



LCC

- Special applications
- Standard and (customer specified) tailor made profiles
- Double or single ended
- With or without chipbreaker
- Size 13 – For machining in small bore sizes and axial machining at small diameters
- Size 16 – For general machining
- Size 30 – For heavy machining

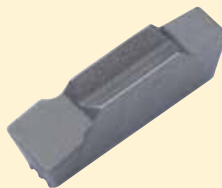

Select narrow inserts if small cutting depths and feed rates are to be used.
Select wide inserts if large cutting depths and feed rates are to be used.

FT (Fine Turning)

- For fine turning
- For deep grooving

FT 19 and 28 (Fine Turning)

- For fine turning
- For parting-off
- For deep grooving

MT (Medium Turning)

- For medium turning
- For shallow grooving

MG (Medium Grooving)

- For medium turning
- For deep grooving
- For parting-off

MC (Medium Cut-off)

- For parting-off tubes and small diameter workpieces
- Reduces vibration risk
- For deep grooving

GG (Grooving Ground)

- Ground chipgroove
- For medium grooving, complement to FT for precision grooves

GS (Grooving Sharp)

- Sharp edge
- For fine grooving in non-ferrous materials/superalloys
- Precision grooves



A55/A60, G55/G60, ISO

- For threading applications



Note! The helix angle should not exceed $\lambda + 2^\circ$.

MP (Medium Profiling)

- For medium profiling
- For medium turning
- For medium grooving
- Good accessibility







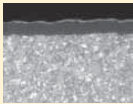
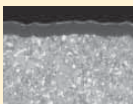

RP (Round Profiling)

- For fine and medium profiling, turning and grooving
- Sharp periphery ground edges
- For superalloys, titanium alloys and non-ferrous materials



Grades

	<p>CP200</p>	<p>PVD-coated, hard micrograin grade with great wear resistance, intended for grooving, parting-off and profiling of superalloys, titanium alloys and hardened steels. A more wear resistant alternative to grade 890.</p> <p>(Ti,Al)N + TiN</p>
	<p>CP500</p>	<p>Tough versatile PVD-coated micrograin grade intended for grooving in a variety of workpiece materials. Universal choice.</p> <p>(Ti,Al)N + TiN</p>
	<p>CP600</p>	<p>Very tough PVD-coated fine-grain grade intended for deep grooving and parting-off at low to moderate cutting speeds. Well-suited in deep grooving and in interrupted cuts. Tougher alternative to CP500.</p> <p>(Ti,Al)N + TiN</p>
	<p>TGK1500</p>	<p>Wear-resistant, hard Duratomic® CVD-coated grade intended for grooving and profiling of grey cast iron and nodular cast iron.</p> <p>Ti(C,N) + Al₂O₃</p>
	<p>TGP25</p>	<p>A wear-resistant Duratomic® CVD-coated grade intended for grooving, turning and profiling of steels at high cutting speeds.</p> <p>Ti(C,N) + Al₂O₃</p>
	<p>883</p>	<p>Uncoated, hard grade intended for grooving, parting-off and profiling of superalloys, titanium alloys, hardened steels and non-ferrous materials.</p>
	<p>890</p>	<p>Uncoated, very hard micrograin grade intended for grooving and profiling of superalloys, titanium alloys, hardened steels and non-ferrous materials. More wear resistant alternative to grade 883.</p>

Information regarding CBN grades for MDT, please see page(s) 70.

Grades, PCBN

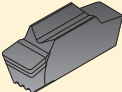
<p>CBN010</p> 	<p>Single-ended inserts with brazed tip, intended for hardened steels and Ni-based superalloys.</p> <p>Composition: 50% cBN content grade with an average grain size of 2 μm and a TiC ceramic binder.</p> <p>Coating: No coating.</p>
<p>CBN10</p> 	<p>Single-ended inserts with brazed tip, intended for hardened steels.</p> <p>Composition: 50% cBN content grade with an average grain size of 2 μm and a TiC ceramic binder.</p> <p>Coating: No coating.</p>
<p>CBN170</p> 	<p>Single-ended inserts with brazed tip, intended for Ni-based superalloys.</p> <p>Composition: 65% cBN content grade with an average grain size of 2 μm and a TiCN+SiCw ceramic binder.</p> <p>Coating: No coating.</p>
<p>CBN200</p> 	<p>Single-ended inserts with brazed tip, intended for perlitic cast iron and hardened steels.</p> <p>Composition: 90% cBN content grade with an average grain size of 3-6 μm and a Al ceramic binder.</p> <p>Coating: No coating.</p>

Grades

The chart below shows application areas for grades available in the MDT system.

The black areas in the chart indicate a grade's main ISO application groups and the white areas indicate other supplementary application groups.

ISO classification of the grades

Grades	P					M				K				N				S				H						
	P01	P10	P20	P30	P40	P50	M01	M10	M20	M30	M40	K01	K10	K20	K30	K40	N01	N10	N20	N30	S01	S10	S20	S30	H01	H10	H20	H30
TGP25																												
TGK1500																												
CP200																												
CP500																												
CP600																												
890																												
883																												
CBN010																												
CBN10																												
CBN170																												
CBN200																												

MDT – Secolor

To centre

Easy conditions Difficult conditions

FT CP500	MC CP600
FT CP500	MC CP600
MT TGKI500	MT TGP25
MT 883	MT CP500
MT 883	MT CP500
S-LF CBN10 CBN010	S-LF CBN200

Tube

Easy conditions Difficult conditions

MT TGP25	MT TGP25
MT TGP25	MT TGP25
MT TGKI500	MT TGP25
MT 883	MT CP500
MT 883	MT CP500
S-LF CBN10 CBN010	S-LF CBN200





Easy conditions: pre-machined surface, shallow grooves etc.
Difficult conditions: raw surface, deep grooves etc.

Inserts for standard grooves

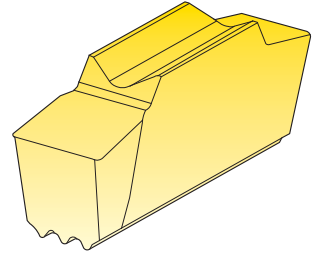
Standard programme

- Double-ended LCGA (MDT13)
- Single-ended LCGN (MDT16)

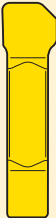

<p>FG – For locking rings</p> 	<p>DY – For dynamic O-rings</p> 	<p>ST – For static O-rings</p> 
<p>R – For full radius grooving</p> 	<p>D76 – For thread undercuts</p> 	

Remember to check the toolholder clearance before using these inserts.

Special applications

- Tailor-made inserts
- LCG.

Special inserts can easily be produced in the styles below.

They are made from blanks, single or double ended, with or without chipbreaker.

(Available as Custom Design at your local Seco website or contact your Seco representative for a special order form to define the required insert.)

<p>Style A</p> <p>Standard or special widths with corner radii</p>	<p>Style B</p> <p>Standard or special widths with corner and crest radii</p>
<p>Style C</p> <p>Standard or special widths with full radius</p>	<p>Style D</p> <p>Standard or special widths with front angle and corner radii</p>
<p>Style F</p> <p>Special widths with double front angles and corner radii</p>	<p>Style G</p> <p>Special widths with double front angles and corner radii</p>
<p>Style J</p> <p>Special widths with radii and chamfers</p>	<p>Style K</p> <p>Special widths with radii, chamfers and angles</p>

Remember to check the toolholder clearance before using these inserts.

Principles

During turning the axial forces deflect the tool generating a necessary trailing edge clearance angle.

This angle depends on

- Feed
- Depth of cut
- Tool overhang
- Insert width
- Cutting speed
- Workpiece material

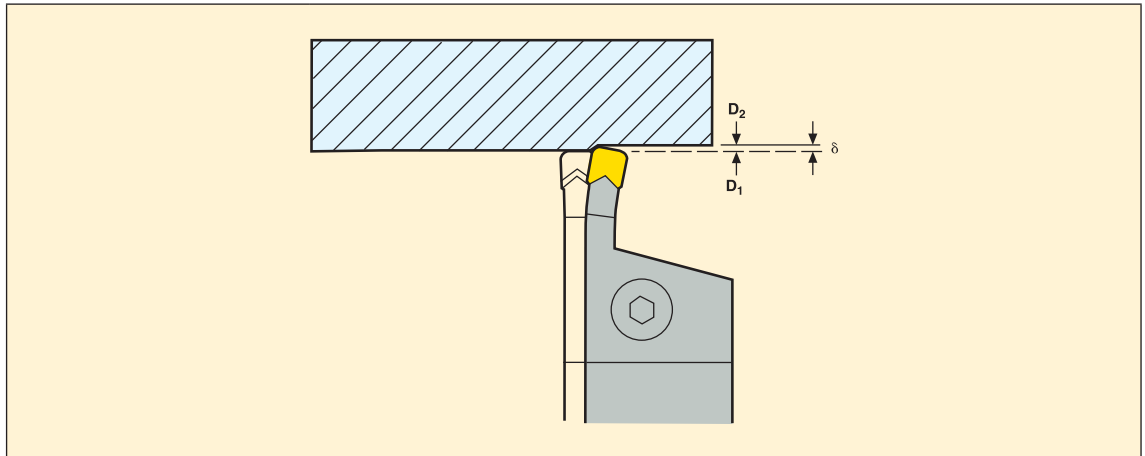
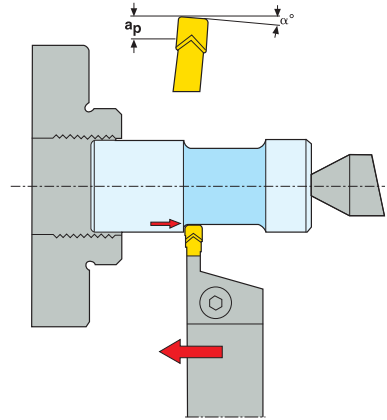

The deflection arising during turning causes a minor change of the actual tool length. This influences the received diameter on the workpiece. The exact amount can be figured by running a test piece. First make a groove and then a turning operation to the same diameter with the selected cutting data. Compare the two different diameters and use the formula to calculate a compensation measure.

$$\delta = \frac{D_1 - D_2}{2}$$

Technical tips

Use the following technical tips for a favourable cutting process considering chipbreaking, cutting forces and tool life.

Machining a deep groove

- Make a central groove to half of the total depth.
- Make infeeds at both sides to the same depth.
- Machine a central groove to full depth.
- Make infeeds at both sides to the full depth.
- Always outfeed, do not rapid traverse.

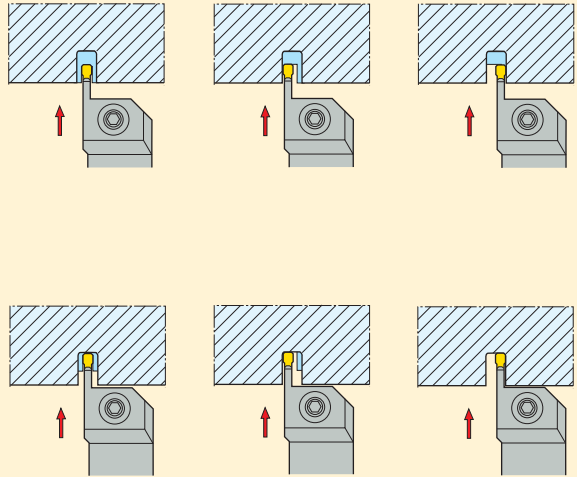

Roughing a recess

If the depth is larger than the width

- Use successive infeeds to required diameter.
- Increment a distance of the insert width – 2 x the insert corner radius to get a flat bottom surface.
- Always outfeed, do not use rapid traverse.

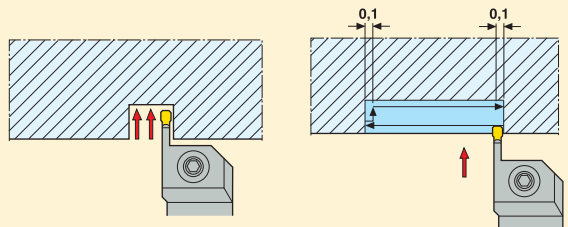

If the width is larger than the depth.

- Start with an infeed at one end.
- Use successive alternating turning with infeeds at the end.
- Release the tool deflection after turning before infeeding (reverse feed and reposition the insert before infeed – 0,1 mm).

Finishing a recess with corner radius or chamfer

- Machine the face down to the end point of the radius or chamfer.
- Make a groove to the required depth at the end point of the radius or chamfer.
- Machine down to the end point of the radius or chamfer.
- Machine the radius or chamfer.
- Machine the diameter until the end point of the radius or chamfer is reached (remember to compensate for the deflection).
- Machine the radius or chamfer.

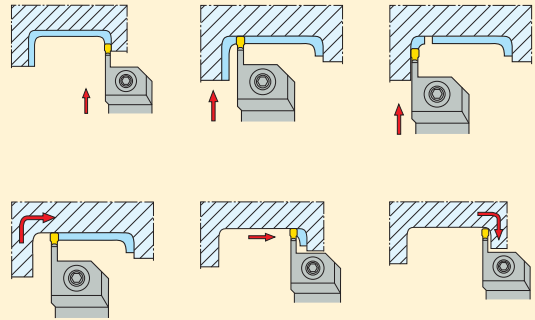

Machining a large corner radius or chamfer

- Make a groove to the required depth at the end point of the radius or chamfer.
- Machine the face down to the end point of the radius or chamfer.
- Machine the radius or chamfer.
- Continue with turning starting from the groove (remember to compensate for the deflection).

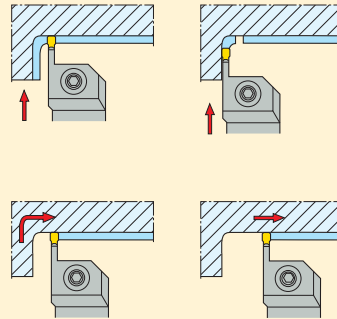

Eliminating a hanging ring

Turning towards the end of a component or towards a recess sometimes produces a hanging ring.

To avoid this

- Stop the turning operation 1,0–1,5 mm before the end of the component or the recess.
- Plunge down to the turned diameter.

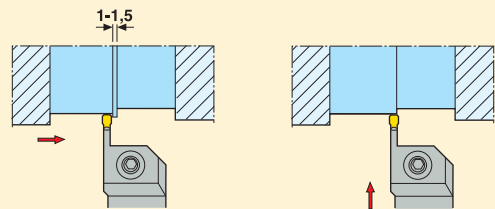

Profiling with round inserts

- The cutting depth should be maximum 0,4 x the insert diameter.
- There is no requirement to generate a trailing edge clearance angle as the geometry will provide that.

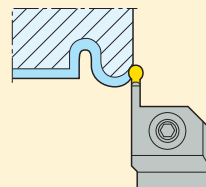

Roughing a recess with round inserts

- Machine the face down to the end point of the radius or chamfer.
- Track around the radius.
- Turn to the end point of the radius or chamfer on the other side.
- Machine down the other side and track around the radius or chamfer.

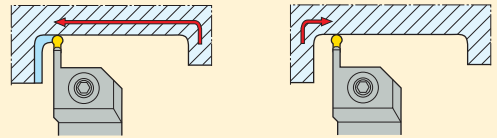

Finishing a recess with round inserts

- Make the cut in one continuous movement.
- Notice the maximum cutting depth allowed during outfeeding (see table).

D mm	a_p mm
2	0,12
3	0,15
4	0,20
5	0,22
6	0,25
8, 10	0,40

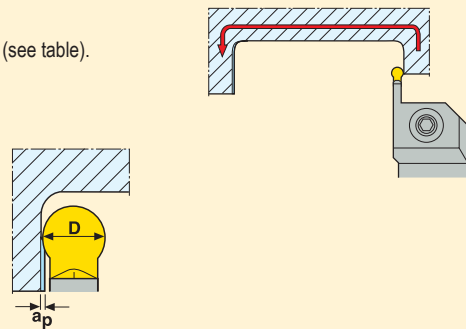

Axial machining

- In axial grooving operations the tool must be adapted to the radius of the groove.
- The toolholder code tells the maximum and minimum diameters that can be handled (see code key).
- The diameter measured on the outside of the blade (D_1) determines the largest diameter of initial plunge.
- The diameter measured on the inside of the blade (D_2) determines the smallest diameter of initial plunge.
- This applies to the initial groove only. Changing to turning means no general restrictions besides collision risk if machining towards centre.

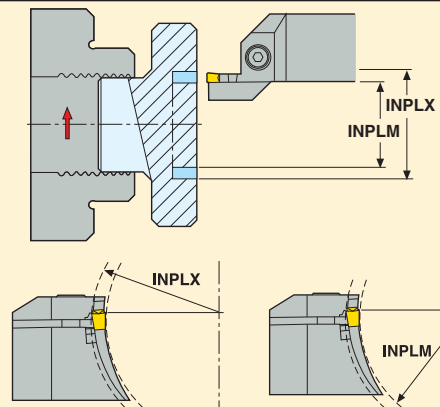

Internal machining

- Generally the same technique as for external machining should be used.
- In blind holes problems can occur with chip evacuation. To avoid that start with making a groove at the inner wall and turn towards the outside.

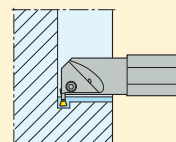

Modular holders, calculation of dimensions after mounting

Example, left hand version (L):

- Blade holder GL (alternative Seco-Capto GL).
- Blade type V21-C.R130.L..

$$l_1 = l_1 \text{ holder} + f_1 \text{ blade}$$

$$f_1 = f_1 \text{ holder} + l_1 \text{ blade}$$

Example, right hand version (R):

- Blade holder GR (alternative Seco-Capto GR).
- Blade type V21-C.L130.R..

$$l_1 = l_1 \text{ holder} + f_1 \text{ blade}$$

$$f_1 = f_1 \text{ holder} + l_1 \text{ blade}$$

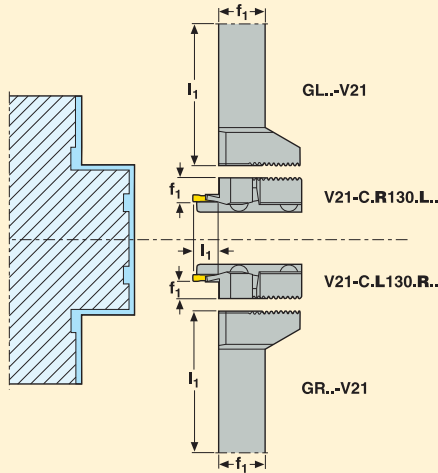

Example, right hand version (R):

- Blade holder FR (alternative Seco-Capto FR).
- Blade type V21-C.R130.L..

$$l_1 = l_1 \text{ holder} + l_1 \text{ blade}$$

$$f_1 = f_1 \text{ holder} + f_1 \text{ blade}$$

Example, left hand version (L):

- Blade holder FL (alternative Seco-Capto FL).
- Blade type V21-C.L130.R..

$$l_1 = l_1 \text{ holder} + l_1 \text{ blade}$$

$$f_1 = f_1 \text{ holder} + f_1 \text{ blade}$$

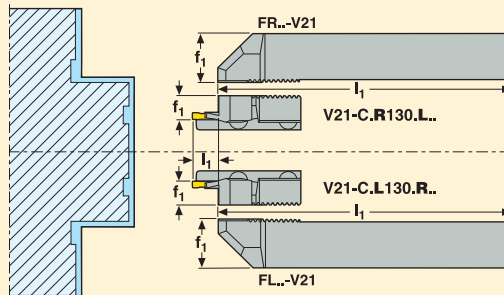

Modular holders, calculation of dimensions after mounting

Example, left hand version (L):

- Blade holder FL (alternative Seco-Capto FL).

- Blade type V21-C.L130.L..

$$l_1 = l_1 \text{ holder} + l_1 \text{ blade}$$

$$f_1 = f_1 \text{ holder} + f_1 \text{ blade}$$

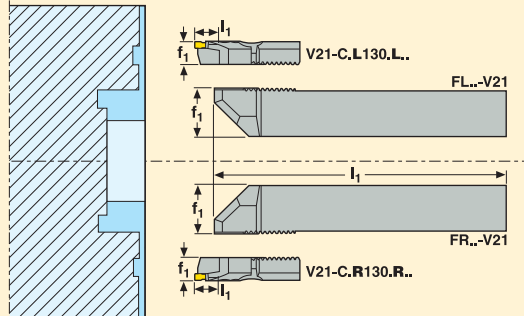

Example, right hand version (R):

- Blade holder FR (alternative Seco-Capto FR).

- Blade type V21-C.R130.R..

$$l_1 = l_1 \text{ holder} + l_1 \text{ blade}$$

$$f_1 = f_1 \text{ holder} + f_1 \text{ blade}$$

Example, left hand version (L):

- Blade holder A..FL (alternative Seco-Capto A..FL).

- Blade type V21-C.L130.L..

$$l_1 = l_1 \text{ holder} + l_1 \text{ blade}$$

$$f_1 = f_1 \text{ holder} + f_1 \text{ blade}$$

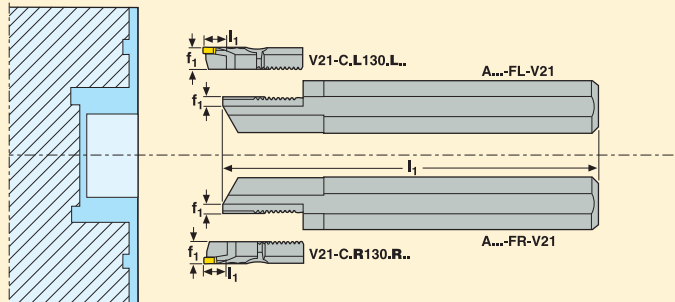

Example, right hand version (R):

- Blade holder A..FR (alternative Seco-Capto A..FR).

- Blade type V21-C.R130.R..

$$l_1 = l_1 \text{ holder} + l_1 \text{ blade}$$

$$f_1 = f_1 \text{ holder} + f_1 \text{ blade}$$

Bars A25R-F... can enter a minimum diameter DCINN ≥ 25 mm.

Bars A32S-F... can enter a minimum diameter DCINN ≥ 32 mm.



Modular holders, calculation of dimensions after mounting

Example, left hand version (L):

- Blade holder SL (alternative Seco-Capto SL).
 - Blade type V21-C.R...or V21-C.R...L...
- $l_1 = l_1 \text{ holder} + 0,71 \times (f_1 \text{ blade} + l_1 \text{ blade})$
 $f_1 = f_1 \text{ holder} + 0,71 \times (l_1 \text{ blade} - f_1 \text{ blade})$

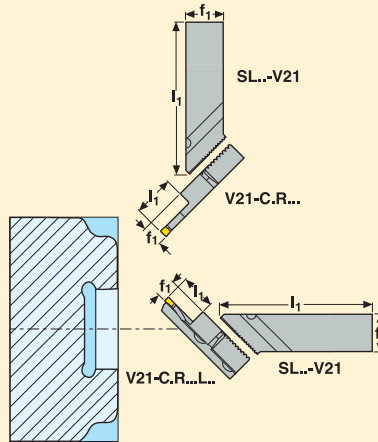

Example, right hand version (R):

- Blade holder SR (alternative Seco-Capto SR).
 - Blade type V21-C.L...or V21-C.L...R...
- $l_1 = l_1 \text{ holder} + 0,71 \times (f_1 \text{ blade} + l_1 \text{ blade})$
 $f_1 = f_1 \text{ holder} + 0,71 \times (l_1 \text{ blade} - f_1 \text{ blade})$

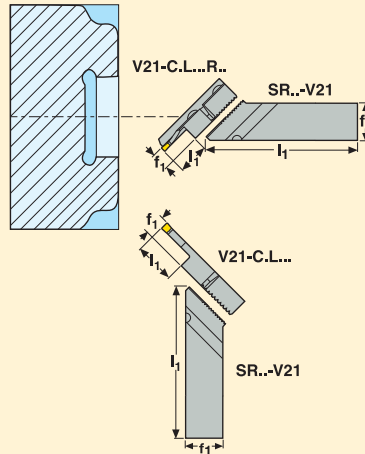

Dimensions relevant for toolholder use

<p>DCINN (D_m min)</p>	<p>DCINN3 (D_{m2})</p>
<p>D_m (D_{max})</p>	<p>INPLM/INPLX</p>
<p>D_m ..RB</p>	

Working depths

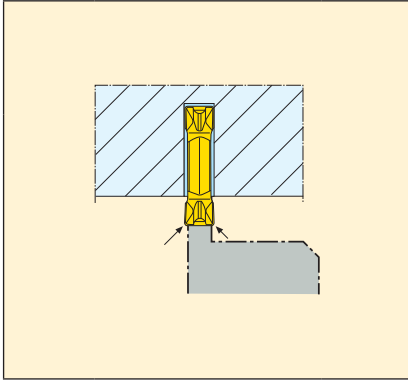

These working depths can be limited when using double ended inserts because of their design.

L...13 = a_r max 11

L...16 = a_r max 14

L...19 = a_r max 16

L...28 = a_r max 26

L...30 = a_r max 28

Torque values for clamping screws

Torque keys, please see page(s) 686-687.

Screw	Nm
L85011-T15P	5,0
L85012-T15P	5,0
L86015-T20P	6,0
MC6S4..	4,0
MC6S5..	6,0
TCEI04..	3,5
TCEI05..	6,0
TCEI06..	8,0
TCEI08..	10,0
TCEI10..	15,0

General recommendations

- Use medium to high feeds for general grooving.
- Use medium to low feeds for precision grooving.
- Always use reverse feed instead of rapid traverse out of grooves.
- Do not use too low cutting depths and feed rates for finishing and semi-finishing turning operations.
- The appropriate deflection must be achieved. Minimum cutting depths and feed rates are shown in the table below.
- When profiling with round inserts do not use cutting depths over 0,4 x the insert diameter.
- Lower the cutting data when using holders with reach $a_r \geq 5 \times a_p$ because the extra length makes them deflect more.
- Maximum overhang with CGGR/L holders should be 3 x the tool diameter.

Minimum cutting depth (a_p) and feed rate (f)

Insert	Min a_p	Min f	Insert	Min a_p	Min f
2-FT	0,15 mm	0,04 mm	5-FT	0,5 mm	0,09 mm
3-FT	0,3 mm	0,05 mm	5-MT	0,5 mm	0,18 mm
3-MT	0,3 mm	0,10 mm	5-MG	0,5 mm	0,10 mm
3-MG	0,5 mm	0,05 mm	5-MC	0,5 mm	0,05 mm
3-MC	0,5 mm	0,05 mm	6-FT	0,6 mm	0,10 mm
4-FT	0,4 mm	0,08 mm	6-MT	0,6 mm	0,20 mm
4-MT	0,4 mm	0,15 mm	6-MG	0,6 mm	0,10 mm
4-MG	0,5 mm	0,10 mm	6-MC	0,5 mm	0,10 mm
4-MC	0,5 mm	0,05 mm	8-FT	0,7 mm	0,25 mm

MDT 13 – Cutting depth and feed rate recommendations

Recommended cutting depths and feed rates for the different insert geometries are found in the charts below.

Geometry -FT

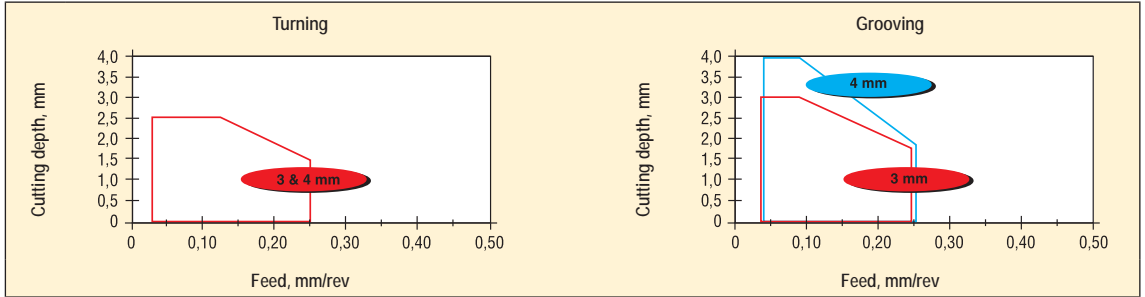

Geometry -MC

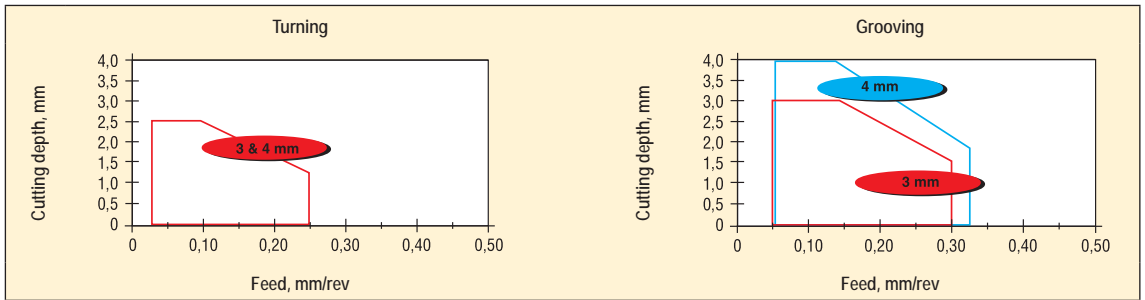

Geometry -MP

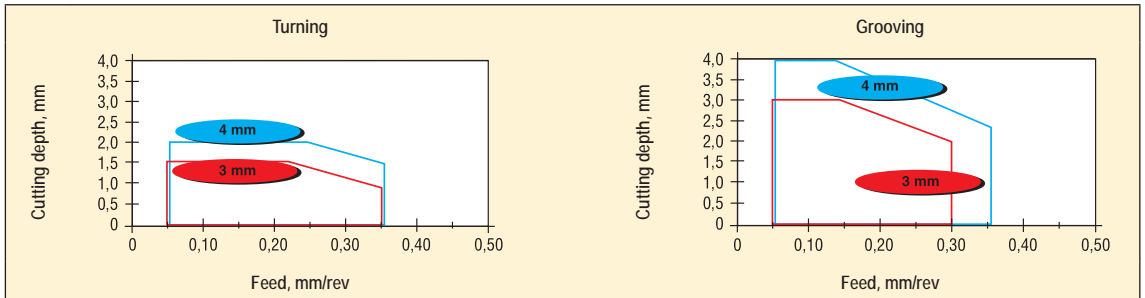

MDT 16 and 30 – Cutting depth and feed rate recommendations

Recommended cutting depths and feed rates for the different insert geometries are found in the charts below.

Geometry -FT

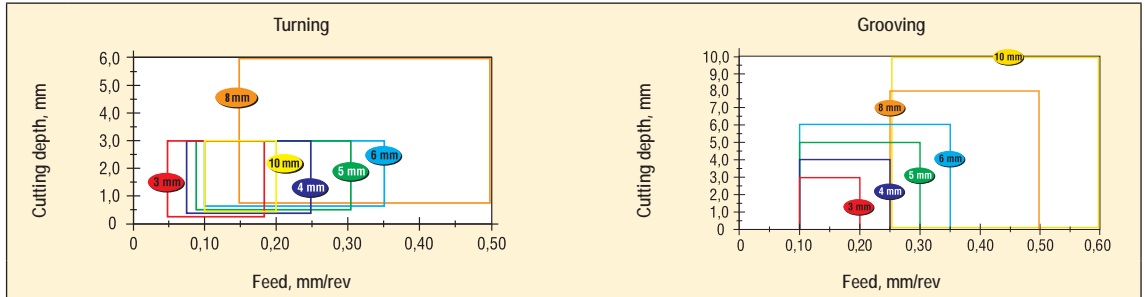

Geometry -MT

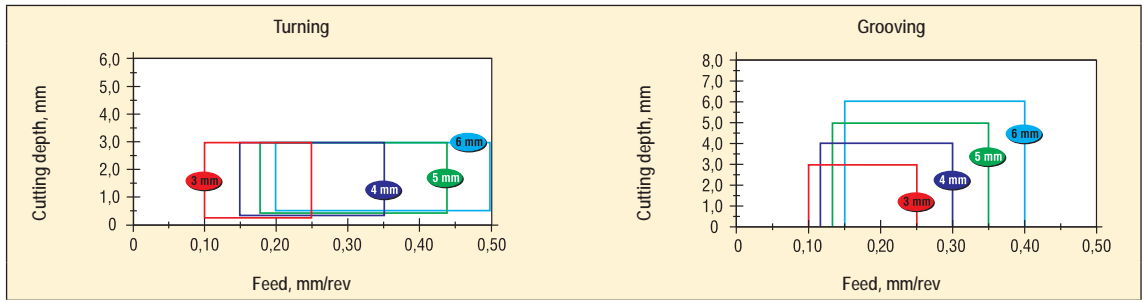

Geometry -MG

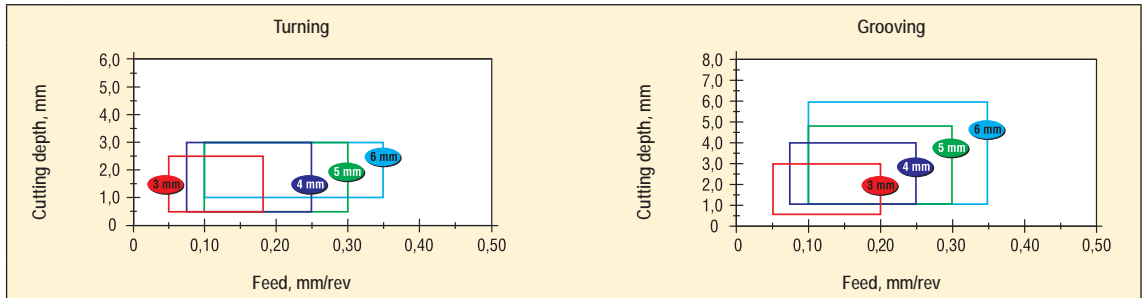

Geometry -MC

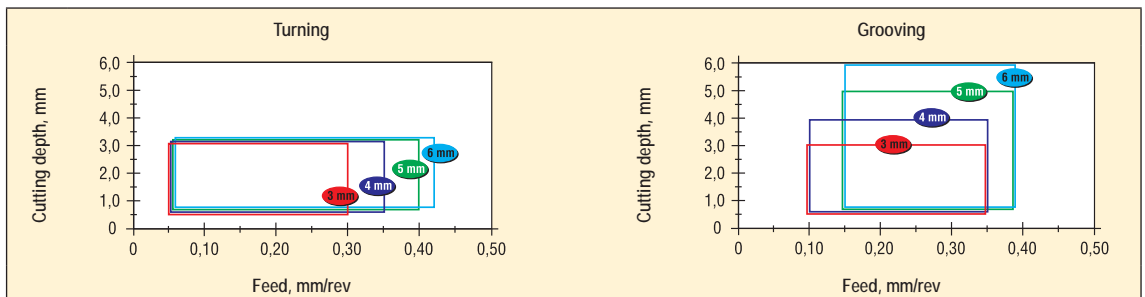

Geometry -MP

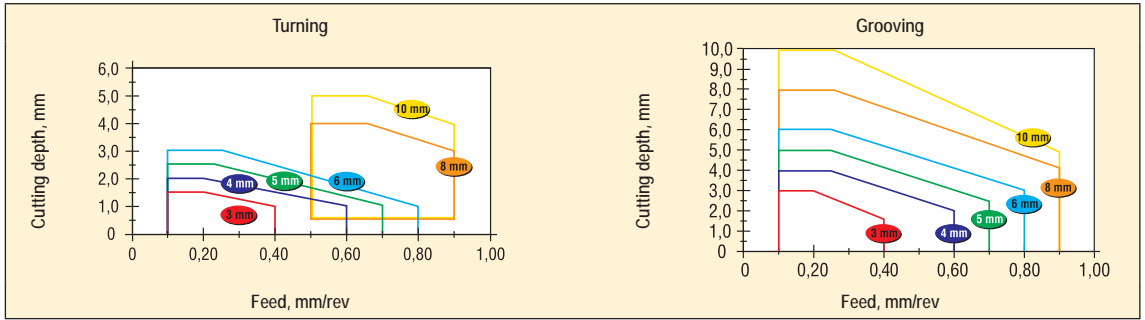

LCGF..-RP

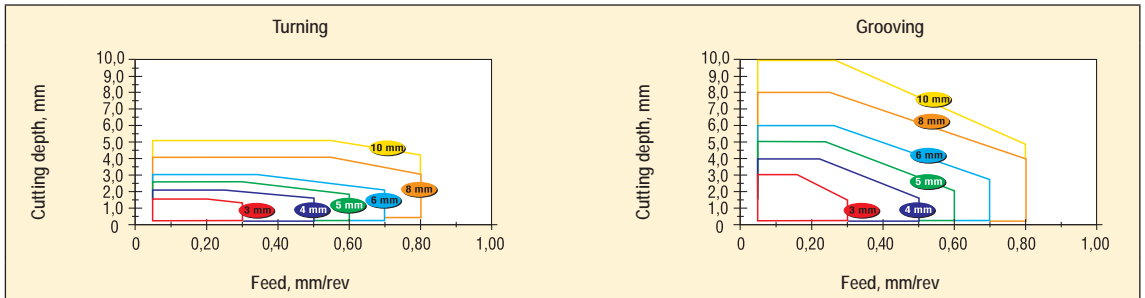

MDT 19 and 28 – Cutting depth and feed rate recommendations

Recommended cutting depths and feed rates for the different insert geometries are found in the charts below.

LCMF..-FT

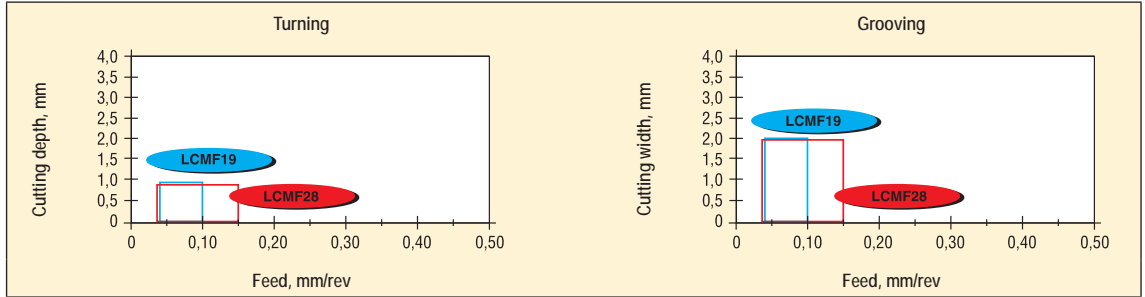

LCMF..-MP

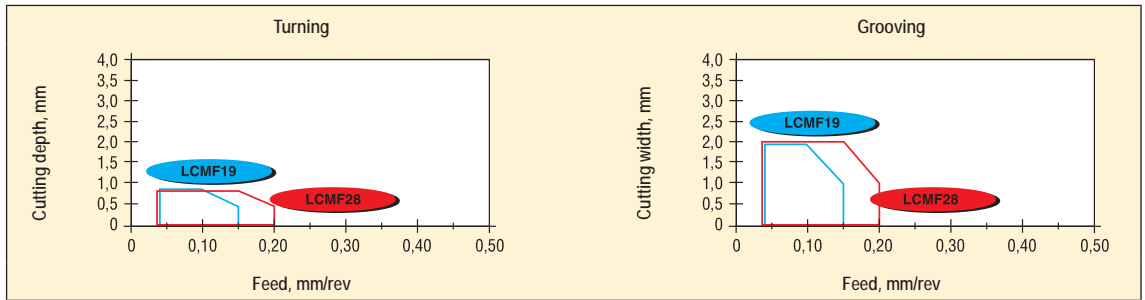

Cutting speed, v_c (m/min)

In this section a recommended cutting speed is indicated under specified conditions.

Use the tables beginning on page(s) 688 to classify the workpiece material into a SMG.

The cutting data tables provide a recommendation of chipbreaker and a start value for feed rate (f) and cutting speed (v_c).

The cutting data tables are based on grooving with full cutting width (a_p).

The recommended cutting speeds in the tables are calculated for 15 minutes tool life with use of external flood coolant.

In order to increase the accuracy towards the actual cutting conditions and requirements of the applications the recommendation is to use My Pages – Suggest on www.secotools.com

v_c = cutting speed (m/min)

a_p = insert width (mm)

f = feed rate (mm/rev)

CP500

SMG		$a_p = 2$		$a_p = 3$		$a_p = 4$		$a_p = 5-6$		$a_p = 8-10$	
		f	v_c	f	v_c	f	v_c	f	v_c	f	v_c
P1	-FT CP500	0,085	235	0,16	185	0,19	175	0,26	150	0,36	130
P2	-FT CP500	0,085	230	0,16	180	0,19	170	0,26	145	0,36	125
P3	-FT CP500	0,085	200	0,15	160	0,18	150	0,24	130	0,34	110
P4	-FT CP500	0,080	175	0,15	140	0,18	130	0,24	115	0,34	100
P5	-FT CP500	0,080	170	0,14	140	0,18	125	0,24	110	0,34	95
P6	-FT CP500	0,080	190	0,14	155	0,17	145	0,24	125	0,32	110
P7	-FT CP500	0,080	180	0,14	145	0,17	135	0,24	115	0,32	100
P8	-FT CP500	0,085	165	0,15	135	0,18	125	0,24	110	0,34	95
P11	-FT CP500	0,080	175	0,14	140	0,17	130	0,24	115	0,32	100
M1	-FT CP500	0,085	265	0,16	200	0,19	170	0,26	125	0,36	80
M2	-FT CP500	0,080	215	0,14	175	0,18	145	0,24	110	0,34	70
M3	-FT CP500	0,065	165	0,12	145	0,14	130	0,19	100	0,26	75
M4	-FT CP500	0,055	120	0,10	115	0,12	105	0,17	85	0,24	60
M5	-FT CP500	0,055	100	0,10	95	0,12	90	0,17	70	0,24	50
K1	-FT CP500	0,085	215	0,16	165	0,19	150	0,26	135	0,36	115
K2	-FT CP500	0,080	190	0,14	145	0,18	125	0,24	105	0,34	85
K3	-FT CP500	0,080	160	0,14	120	0,18	105	0,24	90	0,34	70
K4	-FT CP500	0,080	150	0,14	115	0,18	100	0,24	85	0,34	70
K5	-FT CP500	0,070	95	0,13	70	0,16	65	0,22	55	0,30	44
K6	-FT CP500	0,080	135	0,14	105	0,18	95	0,24	85	0,34	75
K7	-FT CP500	0,070	120	0,13	90	0,16	80	0,22	70	0,30	55
N11	-FT CP500	0,11	140	0,20	110	0,24	100	0,34	85	0,46	75
S1	-FT CP500	0,055	29	0,10	24	0,12	22	0,17	20	0,24	17
S2	-FT CP500	0,055	25	0,10	21	0,12	19	0,17	17	0,24	15
S3	-FT CP500	0,050	22	0,095	18	0,11	17	0,15	15	0,22	13

TGP25

SMG		ap = 3		ap = 4		ap = 5		ap = 6		ap = 8-10	
		f	v _c	f	v _c	f	v _c	f	v _c	f	v _c
P1	-FT TGP25	0,16	380	0,19	345	0,24	300	0,26	280	0,36	225
P2	-FT TGP25	0,16	370	0,19	335	0,24	290	0,26	275	0,36	220
P3	-FT TGP25	0,15	270	0,18	245	0,22	225	0,24	215	0,34	185
P4	-FT TGP25	0,15	290	0,18	260	0,22	230	0,24	220	0,34	175
P5	-FT TGP25	0,14	230	0,18	210	0,22	190	0,24	180	0,34	155
P6	-FT TGP25	0,14	320	0,17	290	0,22	250	0,24	235	0,32	190
P7	-FT TGP25	0,14	245	0,17	225	0,22	200	0,24	195	0,32	170
P8	-FT TGP25	0,15	225	0,18	210	0,22	190	0,24	180	0,34	155
P11	-FT TGP25	0,14	235	0,17	220	0,22	195	0,24	190	0,32	165
M1	-MC TGP25	0,16	290	0,19	265	0,24	225	0,26	205	0,36	145
M2	-MC TGP25	0,14	240	0,18	220	0,22	190	0,24	180	0,34	125
M3	-MC TGP25	0,12	185	0,14	180	0,17	170	0,19	160	0,26	125
M4	-MC TGP25	0,10	140	0,12	140	0,15	135	0,17	125	0,24	100
K1	-MT TGP25	0,18	260	0,22	230	0,26	210	0,28	200	0,38	160
K2	-MT TGP25	0,16	175	0,19	165	0,24	150	0,26	145	0,34	125
K3	-MT TGP25	0,16	150	0,19	140	0,24	125	0,26	120	0,34	105
K4	-MT TGP25	0,16	140	0,19	135	0,24	120	0,26	115	0,34	105
K5	-MT TGP25	0,15	85	0,18	80	0,20	75	0,22	75	0,30	65
K6	-MT TGP25	0,16	165	0,19	155	0,24	135	0,26	125	0,34	105
K7	-MT TGP25	0,15	110	0,18	105	0,20	100	0,22	95	0,30	85

CP600

SMG		ap = 3		ap = 4		ap = 5		ap = 6	
		f	v _c	f	v _c	f	v _c	f	v _c
P1	-MC CP600	0,26	155	0,28	140	0,30	135	0,30	130
P2	-MC CP600	0,26	150	0,28	135	0,30	130	0,32	125
P3	-MC CP600	0,24	135	0,28	115	0,28	115	0,30	110
P4	-MC CP600	0,24	115	0,26	105	0,28	100	0,28	100
P5	-MC CP600	0,24	110	0,26	100	0,28	95	0,28	95
P6	-MC CP600	0,24	125	0,26	115	0,28	110	0,28	110
P7	-MC CP600	0,24	120	0,26	105	0,28	100	0,28	100
P8	-MC CP600	0,24	110	0,28	100	0,28	95	0,30	95
P11	-MC CP600	0,24	115	0,26	105	0,28	100	0,28	100
M1	-MC CP600	0,26	145	0,28	110	0,30	100	0,32	90
M2	-MC CP600	0,24	125	0,26	95	0,28	85	0,28	85
M3	-MC CP600	0,19	110	0,20	95	0,22	85	0,22	85
M4	-MC CP600	0,16	95	0,18	75	0,19	70	0,20	70
M5	-MC CP600	0,16	75	0,18	65	0,19	60	0,20	55
K1	-MC CP600	0,26	135	0,28	125	0,30	120	0,32	115
K2	-MC CP600	0,24	110	0,26	95	0,28	90	0,28	90
K3	-MC CP600	0,24	95	0,26	80	0,28	75	0,28	75
K4	-MC CP600	0,24	90	0,26	80	0,28	75	0,28	75
K5	-MC CP600	0,22	55	0,24	49	0,24	48	0,26	45
K6	-MC CP600	0,24	85	0,26	80	0,28	75	0,28	75
K7	-MC CP600	0,22	70	0,24	60	0,24	60	0,26	60
N11	-MC CP600	0,32	90	0,36	80	0,38	80	0,40	75
S1	-MC CP600	0,16	20	0,18	18	0,19	18	0,20	17
S2	-MC CP600	0,16	17	0,18	16	0,19	15	0,20	15
S3	-MC CP600	0,15	15	0,17	14	0,18	13	0,18	13

CP600

SMG		ap = 2	
		f	v _c
P1	-FT CP600	0,085	210
P2	-FT CP600	0,090	200
P3	-FT CP600	0,085	175
P4	-FT CP600	0,080	160
P5	-FT CP600	0,080	150
P6	-FT CP600	0,080	170
P7	-FT CP600	0,080	160
P8	-FT CP600	0,085	150
P11	-FT CP600	0,080	155
M1	-FT CP600	0,090	240
M2	-FT CP600	0,080	195
M3	-FT CP600	0,065	155
M4	-FT CP600	0,055	115
M5	-FT CP600	0,055	95
K1	-FT CP600	0,090	185
K2	-FT CP600	0,080	165
K3	-FT CP600	0,080	140
K4	-FT CP600	0,080	135
K5	-FT CP600	0,070	85
K6	-FT CP600	0,080	120
K7	-FT CP600	0,070	105
N11	-FT CP600	0,11	125
S1	-FT CP600	0,055	26
S2	-FT CP600	0,055	22
S3	-FT CP600	0,055	19

TGK1500

SMG		ap = 2		ap = 3		ap = 4		ap = 5		ap = 6-8	
		f	v _c	f	v _c	f	v _c	f	v _c	f	v _c
K1	-MT, -FT TGK1500	0,10	295	0,18	230	0,22	205	0,26	185	0,30	165
K2	-MT, -FT TGK1500	0,095	180	0,16	155	0,20	145	0,24	135	0,28	125
K3	-MT, -FT TGK1500	0,095	150	0,16	130	0,20	120	0,24	110	0,28	105
K4	-MT, -FT TGK1500	0,095	145	0,16	125	0,20	115	0,24	105	0,28	100
K5	-MT, -FT TGK1500	0,085	90	0,15	75	0,19	70	0,22	65	0,24	65
K6	-MT, -FT TGK1500	0,095	180	0,16	150	0,20	130	0,24	120	0,28	105
K7	-MT, -FT TGK1500	0,085	110	0,15	95	0,19	90	0,22	85	0,24	80

883

SMG		ap = 3		ap = 4		ap = 5		ap = 6		ap = 8-10	
		f	v _c	f	v _c	f	v _c	f	v _c	f	v _c
K1	-MT 883, 890	0,19	95	0,22	90	0,26	80	0,28	80	0,38	65
K2	-MT 883, 890	0,17	85	0,20	80	0,24	75	0,26	70	0,34	60
K3	-MT 883, 890	0,17	70	0,20	65	0,24	60	0,26	60	0,34	50
K4	-MT 883, 890	0,17	70	0,20	65	0,24	60	0,26	55	0,34	49
K5	-MT 883, 890	0,15	43	0,18	40	0,20	37	0,22	36	0,30	31
K6	-MT 883, 890	0,17	60	0,20	55	0,24	50	0,26	50	0,34	43
K7	-MT 883, 890	0,15	55	0,18	50	0,20	48	0,22	46	0,30	40
N1	-MT 883, 890	0,24	275	0,28	255	0,32	235	0,36	220	0,48	190
N2	-MT 883, 890	0,24	220	0,28	205	0,32	190	0,36	180	0,48	155
N3	-MT 883, 890	0,24	145	0,28	135	0,32	125	0,36	120	0,48	100
N11	-MT 883, 890	0,24	170	0,28	155	0,32	145	0,36	135	0,48	115
S1	-MT 883, 890	0,12	19	0,14	18	0,16	17	0,18	16	0,24	14
S2	-MT 883, 890	0,12	15	0,14	14	0,16	14	0,18	13	0,24	11
S3	-MT 883, 890	0,11	14	0,13	13	0,15	12	0,17	11	0,22	10
S11	-MT 883, 890	0,13	27	0,16	25	0,19	23	0,20	22	0,28	19
S12	-MT 883, 890	0,13	21	0,16	19	0,19	18	0,20	17	0,28	15
S13	-MT 883, 890	0,12	16	0,14	15	0,16	15	0,18	14	0,24	12
H5	-MT 883, 890	0,11	33	0,13	31	0,16	28	0,17	27	0,24	24

CP200

SMG		ap = 3		ap = 4		ap = 5		ap = 6		ap = 8	
		f	v _c	f	v _c	f	v _c	f	v _c	f	v _c
M1	-FT CP200	0,16	210	0,19	180	0,24	145	0,26	130	0,36	85
M2	-FT CP200	0,14	185	0,18	155	0,22	125	0,24	115	0,32	80
M3	-FT CP200	0,12	150	0,14	135	0,17	120	0,19	110	0,26	75
M4	-FT CP200	0,10	120	0,12	110	0,15	95	0,17	90	0,22	70
M5	-FT CP200	0,10	100	0,12	95	0,15	80	0,17	75	0,22	55
S1	-FT CP200	0,10	28	0,12	26	0,15	24	0,17	23	0,22	20
S2	-FT CP200	0,10	22	0,12	21	0,15	19	0,17	18	0,22	16
S3	-FT CP200	0,095	19	0,11	18	0,14	17	0,15	16	0,20	15
S11	-FT CP200	0,12	38	0,14	35	0,17	33	0,19	31	0,26	27
S12	-FT CP200	0,12	29	0,14	27	0,17	25	0,19	24	0,26	21
S13	-FT CP200	0,10	24	0,12	22	0,15	20	0,17	19	0,22	17



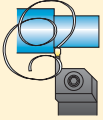
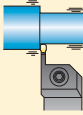
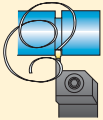

Machining problems

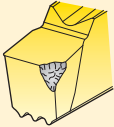
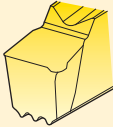
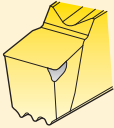
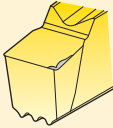
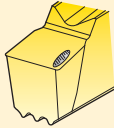
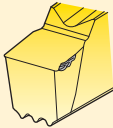
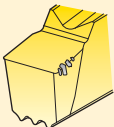
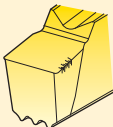
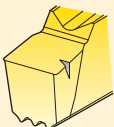
<p>Chipbreaking problems/ turning</p> 	<ul style="list-style-type: none"> • Increase feed rate or cutting depth. • Use narrower insert with smaller radius. 	<p>Vibrations</p> 	<ul style="list-style-type: none"> • Change the cutting speed. • Increase the feed rate. • Reduce the cutting depth. • Improve the stability of the tool and workpiece. • Select an insert with smaller radius.
<p>Chipbreaking problems/ grooving</p> 	<ul style="list-style-type: none"> • Reduce the cutting speed. • Increase the feed rate. • Use interrupted feed. 		

Tool life problems

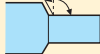
<p>Breakage</p> 	<ul style="list-style-type: none"> • Reduce the feed rate. • Reduce the cutting depth. • Select a tougher grade. • Select an insert with larger radius. 	<p>Plastic deformation</p> 	<ul style="list-style-type: none"> • Reduce the cutting speed. • Reduce the feed rate. • Use coolant. • Select a more wear resistant grade. • Select an insert with larger radius.
<p>Rapid flank wear</p> 	<ul style="list-style-type: none"> • Reduce the cutting speed. 	<p>Built-up edge</p> 	<ul style="list-style-type: none"> • Increase the cutting speed. • Increase the feed rate. • Do not use coolant.
<p>Rapid crater wear</p> 	<ul style="list-style-type: none"> • Reduce the cutting speed. • Reduce the feed rate. • Use coolant. • Select a more wear resistant grade. 	<p>Chip hammering</p> 	<ul style="list-style-type: none"> • Change the feed rate. • Change the cutting depth.
<p>Chipping</p> 	<ul style="list-style-type: none"> • Increase the cutting speed. • Reduce the feed rate. • Select a tougher grade. 	<p>Comb cracks</p> 	<ul style="list-style-type: none"> • Reduce the cutting speed. • Reduce the feed rate. • Use abundant coolant flow or no coolant at all.
<p>Notch wear</p> 	<ul style="list-style-type: none"> • Reduce the cutting speed. • Reduce the feed rate. 		

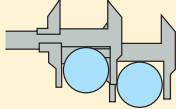
Workpiece out of tolerance

<p>Poor surface finish</p> 	<ul style="list-style-type: none"> • Reduce the feed rate. • Increase the cutting speed. • Reduce the cutting depth. • Use coolant. • Improve the stability of the tool and workpiece. 	<p>Inaccurate square facing</p> 	<ul style="list-style-type: none"> • Final facing should be made as radial machining from outside to centre.
<p>Diameter out of tolerance</p> 	<ul style="list-style-type: none"> • Check the tool length compensation measure. • Reduce the cutting speed. • Select a more wear resistant grade. 	<p>Repeatability problems</p> 	<ul style="list-style-type: none"> • Keep machining conditions constant. • Check the insert wear.
<p>Diameter variation</p> 	<ul style="list-style-type: none"> • After grooving the tool must be retracted in accordance with the compensation measurement before proceeding with turning. • Keep machining conditions constant during turning operation. 		

Toolholders for inserts LCGF, LCGN, LCMF and LCMR



• For insert programme, see page(s) 578-591, 593-594

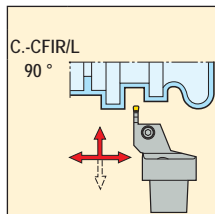
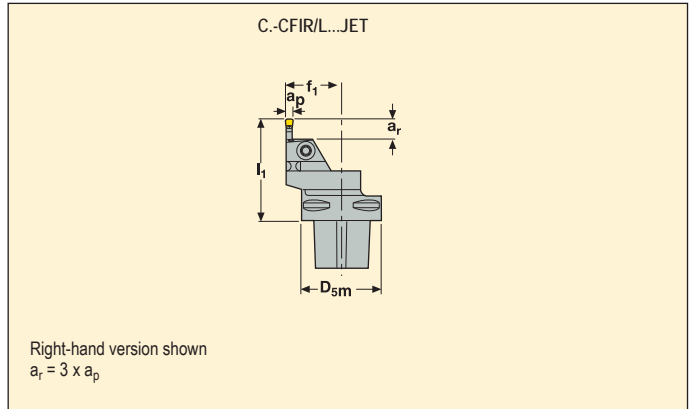

Capto size	Part No.	Dimensions in mm					KG	Seat size	Insert	
		D _{5m}	f ₁	l ₁	a _r **	DCINN3*				
C4	C4-CFIR-27060-03JET	40	27,0	60	9	195	0,5	3	LC..1603..	
	C4-CFIL-27060-03JET	40	27,0	60	9	195	0,5	3	LC..1603..	
	C4-CFIR-27060-04JET	40	27,0	60	12	195	0,5	4	LC..1604..	
	C4-CFIL-27060-04JET	40	27,0	60	12	195	0,5	4	LC..1604..	
	C4-CFIR-27065-05JET	40	27,0	65	15	195	0,5	5	LC..1605..	
	C4-CFIL-27065-05JET	40	27,0	65	15	195	0,5	5	LC..1605..	
C5	C5-CFIR-35060-03JET	50	35,0	60	9	195	0,7	3	LC..1603..	
	C5-CFIL-35060-03JET	50	35,0	60	9	195	0,7	3	LC..1603..	
	C5-CFIR-35065-04JET	50	35,0	65	12	195	0,7	4	LC..1604..	
	C5-CFIL-35065-04JET	50	35,0	65	12	195	0,7	4	LC..1604..	
	C5-CFIR-35065-05JET	50	35,0	65	15	195	0,7	5	LC..1605..	
	C5-CFIL-35065-05JET	50	35,0	65	15	195	0,7	5	LC..1605..	
	C5-CFIR-35075-06JET	50	35,0	75	18	195	0,8	6	LC..1606..	
	C5-CFIL-35075-06JET	50	35,0	75	18	195	0,8	6	LC..1606..	

*DCINN3 – minimum bore diameter for internal application, see page(s) 477.

**Max depth of cut for LCGF/LCMF16 = 14 mm

Spare Parts, Parts included in delivery

For holder	Clamp key	Clamp screw	Torque value Nm
CFIR/L...03	4SMS795	TCEI0513	6,0
CFIR/L...04	5SMS795	TCEI0613	8,0
CFIR/L...05	5SMS795	TCEI0613	8,0
CFIR/L...06	6SMS795	TCEI0815	10,0

Please check availability in current price and stock-list

Toolholders for inserts LCGF, LCGN, LCMF and LCMR



• For insert programme, see page(s) 578-591, 593-594

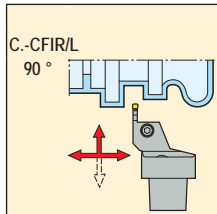
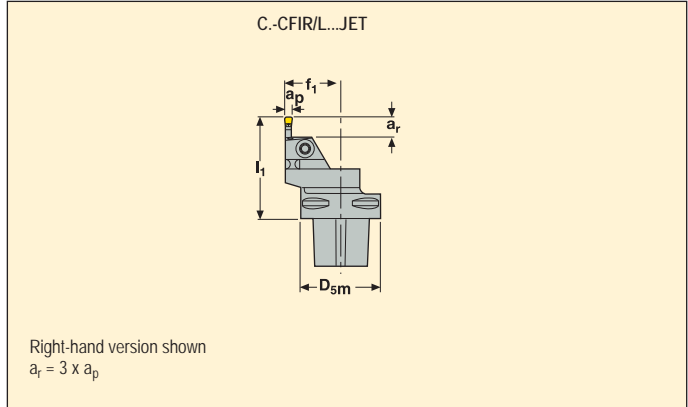

Capto size	Part No.	Dimensions in mm					DCINN3*	KG	Seat size	Insert
		D _{5m}	f ₁	l ₁	a _r **					
C6	C6-CFIR-45065-03JET	63	45,0	65	9	195	1,1	3	LC..1603..	
	C6-CFIL-45065-03JET	63	45,0	65	9	195	1,1	3	LC..1603..	
4	C6-CFIR-45065-04JET	63	45,0	65	12	195	1,1	4	LC..1604..	
	C6-CFIL-45065-04JET	63	45,0	65	12	195	1,1	4	LC..1604..	
5	C6-CFIR-45070-05JET	63	45,0	70	15	195	1,1	5	LC..1605..	
	C6-CFIL-45070-05JET	63	45,0	70	15	195	1,1	5	LC..1605..	
6	C6-CFIR-45075-06JET	63	45,0	75	18	195	1,2	6	LC..1606..	
	C6-CFIL-45075-06JET	63	45,0	75	18	195	1,2	6	LC..1606..	
8	C6-CFIR-45085-08JET	63	45,0	85	24	195	1,3	8	LC..3008..	
	C6-CFIL-45085-08JET	63	45,0	85	24	195	1,3	8	LC..3008..	

*DCINN3 – minimum bore diameter for internal application, see page(s) 477.

**Max depth of cut for LCGF/LCMF16 = 14 mm

Spare Parts, Parts included in delivery

For holder	Clamp key	Clamp screw	Torque value Nm
CFIR/L...-03	4SMS795	TCEI0513	6,0
CFIR/L...-04	5SMS795	TCEI0613	8,0
CFIR/L...-05	5SMS795	TCEI0613	8,0
CFIR/L...-06	6SMS795	TCEI0815	10,0
CFIR/L...-08	6SMS795	TCEI1020	15,0

Please check availability in current price and stock-list

Toolholders for inserts LCGF, LCGN, LCMF and LCMR



• For insert programme, see page(s) 578-591, 593-594

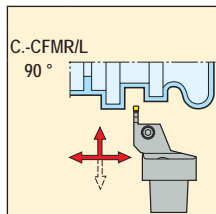
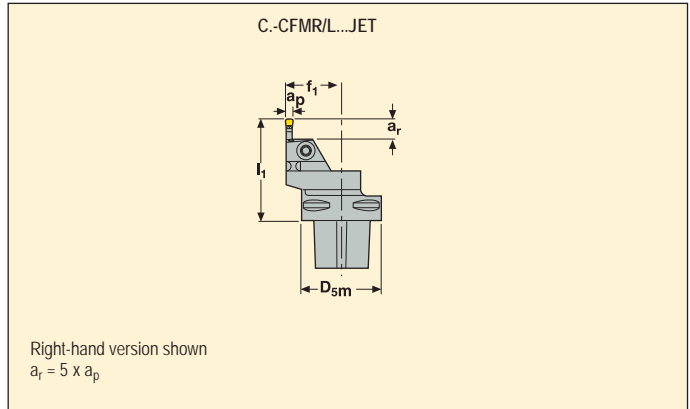

Capto size	Part No.	Dimensions in mm					KG	Seat size	Insert
		D _{5m}	f ₁	l ₁	a _r **	DCINN3*			
C4	C4-CFMR-27070-03JET	40	27,0	70	15	195	0,5	3	LC..1603..
	C4-CFML-27070-03JET	40	27,0	70	15	195	0,5	3	LC..1603..
	C4-CFMR-27070-04JET	40	27,0	70	20	195	0,5	4	LC..1604..
	C4-CFML-27070-04JET	40	27,0	70	20	195	0,5	4	LC..1604..
C5	C5-CFMR-35070-03JET	50	35,0	70	15	195	0,7	3	LC..1603..
	C5-CFML-35070-03JET	50	35,0	70	15	195	0,7	3	LC..1603..
	C5-CFMR-35075-04JET	50	35,0	75	20	195	0,7	4	LC..1604..
	C5-CFML-35075-04JET	50	35,0	75	20	195	0,7	4	LC..1604..
	C5-CFMR-35075-05JET	50	35,0	75	25	195	0,7	5	LC..1605..
	C5-CFML-35075-05JET	50	35,0	75	25	195	0,7	5	LC..1605..
	C5-CFMR-35085-06JET	50	35,0	85	30	195	0,8	6	LC..1606..
	C5-CFML-35085-06JET	50	35,0	85	30	195	0,8	6	LC..1606..

*DCINN3 – minimum bore diameter for internal application, see page(s) 477.

**Max depth of cut for LCGF/LCMF16 = 14 mm

Spare Parts, Parts included in delivery

For holder	Clamp key	Clamp screw	Torque value Nm
CFMR/L...03	4SMS795	TCEI0513	6,0
CFMR/L...04	5SMS795	TCEI0613	8,0
CFMR/L...05	5SMS795	TCEI0613	8,0
CFMR/L...06	6SMS795	TCEI0815	10,0

Please check availability in current price and stock-list

Toolholders for inserts LCGF, LCGN, LCMF and LCMR



• For insert programme, see page(s) 578-591, 593-594

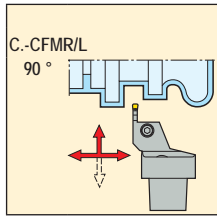
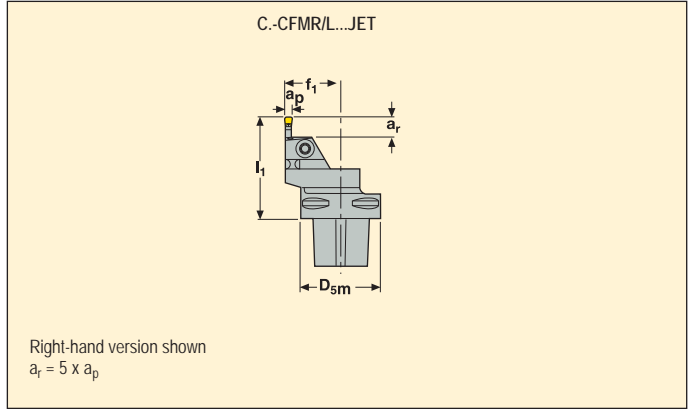

Capto size	Part No.	Dimensions in mm					DCINN3*	KG	Seat size	Insert
		D _{5m}	f ₁	l ₁	a _r **					
C6	C6-CFMR-45080-03JET	63	45,0	80	15	195	2,0	3	LC..1603..	
	C6-CFML-45080-03JET	63	45,0	80	15	195	1,3	3	LC..1603..	
	C6-CFMR-45080-04JET	63	45,0	80	20	195	1,2	4	LC..1604..	
	C6-CFML-45080-04JET	63	45,0	80	20	195	1,2	4	LC..1604..	
	C6-CFMR-45080-05JET	63	45,0	80	25	195	1,1	5	LC..1605..	
	C6-CFML-45080-05JET	63	45,0	80	25	195	1,1	5	LC..1605..	
	C6-CFMR-45085-06JET	63	45,0	85	30	195	1,2	6	LC..1606..	
	C6-CFML-45085-06JET	63	45,0	85	30	195	1,2	6	LC..1606..	

*DCINN3 – minimum bore diameter for internal application, see page(s) 477.

**Max depth of cut for LCGF/LCMF16 = 14 mm

Spare Parts, Parts included in delivery

For holder	Clamp key	Clamp screw	Torque value Nm
CFMR/L...-03	4SMS795	TCEI0513	6,0
CFMR/L...-04	5SMS795	TCEI0613	8,0
CFMR/L...-05	5SMS795	TCEI0613	8,0
CFMR/L...-06	6SMS795	TCEI0815	10,0

Please check availability in current price and stock-list

Toolholders for inserts LCGF, LCGN, LCMF and LCMR



• For insert programme, see page(s) 578-591, 593-594

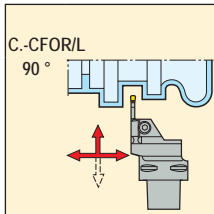
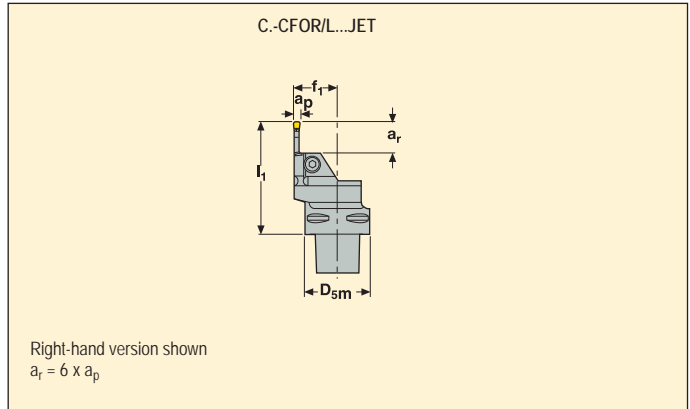

Capto size	Part No.	Dimensions in mm					KG	Seat size	Insert	
		D _{5m}	f ₁	l ₁	a _r **	DCINN3*				
C4	C4-CFOR-27070-03-JET	40	27,0	70	18	195	0,5	3	LC..1603..	
	C4-CFOL-27070-03-JET	40	27,0	70	18	195	0,5	3	LC..1603..	
	C4-CFOR-27080-04-JET	40	27,0	80	24	195	0,5	4	LC..1604..	
	C4-CFOL-27080-04-JET	40	27,0	80	24	195	0,5	4	LC..1604..	
	C4-CFOR-27085-05-JET	40	27,0	85	30	195	0,5	5	LC..1605..	
	C4-CFOL-27085-05-JET	40	27,0	85	30	195	0,5	5	LC..1605..	
C5	C5-CFOR-35070-03-JET	50	35,0	70	18	195	0,7	6	LC..1603..	
	C5-CFOL-35070-03-JET	50	35,0	70	18	195	0,7	6	LC..1603..	
	C5-CFOR-35080-04-JET	50	35,0	80	24	195	0,7	4	LC..1604..	
	C5-CFOL-35080-04-JET	50	35,0	80	24	195	0,8	4	LC..1604..	
	C5-CFOR-35085-05-JET	50	35,0	85	30	195	0,8	5	LC..1605..	
	C5-CFOL-35085-05-JET	50	35,0	85	30	195	0,7	5	LC..1605..	
	C5-CFOR-35100-06-JET	50	35,0	100	36	195	0,9	6	LC..1606..	
	C5-CFOL-35100-06-JET	50	35,0	100	36	195	1,0	6	LC..1606..	

*DCINN3 – minimum bore diameter for internal application, see page(s) 477.

**Max depth of cut for LCGF/LCMF16 = 14 mm

Spare Parts, Parts included in delivery

For holder	Clamp key	Clamp screw	Torque value Nm
CFOR/L...03	4SMS795	TCEI0513	6,0
CFOR/L...04	5SMS795	TCEI0613	8,0
CFOR/L...05	5SMS795	TCEI0613	8,0
CFOR/L...06	6SMS795	TCEI0815	10,0



Please check availability in current price and stock-list

Toolholders for inserts LCGF, LCGN, LCMF and LCMR

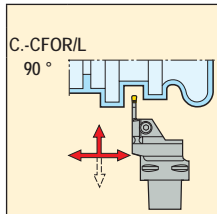
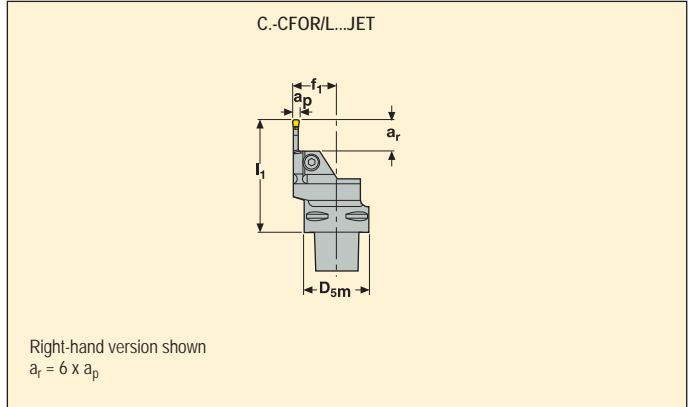

• For insert programme, see page(s) 578-591, 593-594





Capto size		Part No.	Dimensions in mm					KG	Seat size	
			D _{5m}	f ₁	l ₁	a _r **	DCINN3*			
C6	3	C6-CFOR-45075-03-JET	63	45,0	75	18	195	1,2	3	LC..1603..
		C6-CFOL-45075-03-JET	63	45,0	75	18	195	1,1	3	LC..1603..
	4	C6-CFOR-45080-04-JET	63	45,0	80	24	195	1,1	4	LC..1604..
		C6-CFOL-45080-04-JET	63	45,0	80	24	195	1,1	4	LC..1604..
	5	C6-CFOR-45090-05-JET	63	45,0	90	30	195	1,2	5	LC..1605..
		C6-CFOL-45090-05-JET	63	45,0	90	30	195	1,2	5	LC..1605..
	6	C6-CFOR-45100-06-JET	63	45,0	100	36	195	1,3	6	LC..1606..
		C6-CFOL-45100-06-JET	63	45,0	100	36	195	1,3	6	LC..1606..
	8	C6-CFOR-45115-08-JET	63	45,0	115	48	195	1,4	8	LC..3008..
		C6-CFOL-45115-08-JET	63	45,0	115	48	195	1,4	8	LC..3008..

*DCINN3 – minimum bore diameter for internal application, see page(s) 477.

**Max depth of cut for LCGF/LCMF16 = 14 mm, LCGF/LCMF30.. = 28 mm

Spare Parts, Parts included in delivery

For holder	Clamp key	Clamp screw	Torque value Nm
			
CFOR/L...03	4SMS795	TCEI0513	6,0
CFOR/L...04	5SMS795	TCEI0613	8,0
CFOR/L...05	5SMS795	TCEI0613	8,0
CFOR/L...06	6SMS795	TCEI0815	10,0
CFOR/L...08	6SMS795	TCEI1020	15,0

Please check availability in current price and stock-list

Toolholders for inserts LCMF



- For insert programme, see page(s) 577

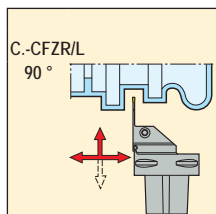
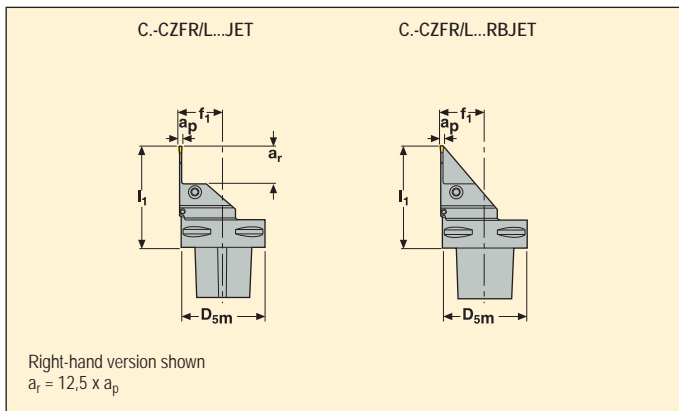

Capto size	Part No.	Dimensions in mm					KG	Seat size	Image
		D _{5m}	f ₁	l ₁	a _r	D _m *			
C4	C4-CFZR-22075-2802JET	40	22,0	75	26	–	0,5	2	LC..2802..
	C4-CFZL-22075-2802JET	40	22,0	75	26	–	0,5	2	LC..2802..
C5	C5-CFZR-27075-2802JET	50	27,0	75	26	–	0,7	2	LC..2802..
	C5-CFZL-27075-2802JET	50	27,0	75	26	–	0,7	2	LC..2802..
C6	C6-CFZR-33075-2802JET	63	33,0	75	26	–	1,0	2	LC..2802..
	C6-CFZL-33075-2802JET	63	33,0	75	26	–	1,0	2	LC..2802..
C4	C4-CFZR-22075-2802RBJET	40	22,0	75	–	52	0,6	2	LC..2802..
	C4-CFZL-22075-2802RBJET	40	22,0	75	–	52	0,6	2	LC..2802..
C5	C5-CFZR-27075-2802RBJET	50	27,0	75	–	52	0,7	2	LC..2802..
	C5-CFZL-27075-2802RBJET	50	27,0	75	–	52	0,7	2	LC..2802..
C6	C6-CFZR-33075-2802RBJET	63	33,0	75	–	52	1,1	2	LC..2802..
	C6-CFZL-33075-2802RBJET	63	33,0	75	–	52	1,1	2	LC..2802..

*Due to the design, grooving depth is limited, see page(s) 477.

Spare Parts, Parts included in delivery

For holder	Clamp key	Clamp screw	Torque value Nm
CFZR/L...02	4SMS795	TCEI0513	6,0

Please check availability in current price and stock-list

Toolholders for inserts LCGF, LCGN, LCMF and LCMR



• For insert programme, see page(s) 578-583, 593-594

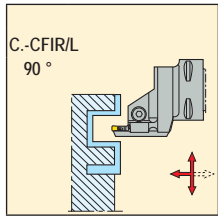
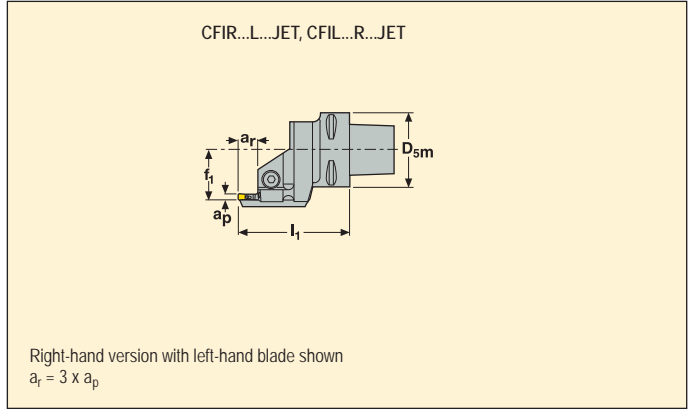

Capto size	Part No.	Dimensions in mm							KG	Seat size	Image
		INPLM	INPLX	D _{sm}	f ₁	l ₁	a _r				
C4	3	C4-CFIR -27060-03L080055-JET	55	80	40	27,0	60	9	0,5	3	LC..1603..
		-27060-03L100070-JET	70	100	40	27,0	60	9	0,5	3	LC..1603..
		-27060-03L130090-JET	90	130	40	27,0	60	9	0,5	3	LC..1603..
		-27060-03L170110-JET	110	170	40	27,0	60	9	0,5	3	LC..1603..
	4	C4-CFIL -27060-03R080055-JET	55	80	40	27,0	60	9	0,5	3	LC..1603..
		-27060-03R100070-JET	70	100	40	27,0	60	9	0,5	3	LC..1603..
		-27060-03R130090-JET	90	130	40	27,0	60	9	0,5	3	LC..1603..
		-27060-03R170110-JET	110	170	40	27,0	60	9	0,5	3	LC..1603..
C4	3	C4-CFIR -27065-04L080055-JET	55	80	40	27,0	65	12	0,5	4	LC..1604..
		-27065-04L100070-JET	70	100	40	27,0	65	12	0,5	4	LC..1604..
		-27065-04L130090-JET	90	130	40	27,0	65	12	0,5	4	LC..1604..
		-27065-04L170110-JET	110	170	40	27,0	65	12	0,5	4	LC..1604..
	4	-27065-04L230140-JET	140	230	40	27,0	65	12	0,5	4	LC..1604..
		C4-CFIL -27065-04R080055-JET	55	80	40	27,0	65	12	0,5	4	LC..1604..
		-27065-04R100070-JET	70	100	40	27,0	65	12	0,5	4	LC..1604..
		-27065-04R130090-JET	90	130	40	27,0	65	12	0,5	4	LC..1604..
4	-27065-04R170110-JET	110	170	40	27,0	65	12	0,5	4	LC..1604..	
	-27065-04R230140-JET	140	230	40	27,0	65	12	0,5	4	LC..1604..	

Initial plunge (INPLM/INPLX) relates to face groove diameter, see page(s) 477.

Spare Parts, Parts included in delivery

For holder	Clamp key	Clamp screw	Torque value Nm
CFIR/L...-03	4SMS795	TCEI0513	6,0
CFIR/L...-04	5SMS795	TCEI0613	8,0

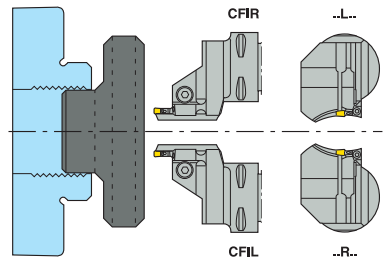

Please check availability in current price and stock-list

Toolholders for inserts LCGF, LCGN, LCMF and LCMR



• For insert programme, see page(s) 578-583, 593-594

CFIR...L...JET, CFIL...R...JET

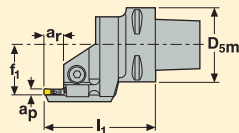

Right-hand version with left-hand blade shown

$$a_r = 3 \times a_p$$

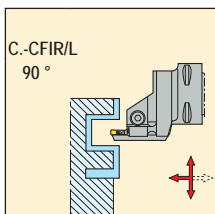

Capto size	Part No.	Dimensions in mm						KG	Seat size	Insert	
		INPLM	INPLX	D _{5m}	f ₁	l ₁	a _r **				
C4	5	C4-CFIR -27065-05L080055-JET	55	80	40	27,0	65	15	0,5	5	LC..1605..
		-27065-05L100070-JET	70	100	40	27,0	65	15	0,5	5	LC..1605..
		-27065-05L130090-JET	90	130	40	27,0	65	15	0,5	5	LC..1605..
		-27065-05L170110-JET	110	170	40	27,0	65	15	0,5	5	LC..1605..
		-27065-05L230140-JET	140	230	40	27,0	65	15	0,5	5	LC..1605..
		C4-CFIL -27065-05R080055-JET	55	80	40	27,0	65	15	0,5	5	LC..1605..
		-27065-05R100070-JET	70	100	40	27,0	65	15	0,5	5	LC..1605..
		-27065-05R130090-JET	90	130	40	27,0	65	15	0,5	5	LC..1605..
		-27065-05R170110-JET	110	170	40	27,0	65	15	0,5	5	LC..1605..
		-27065-05R230140-JET	140	230	40	27,0	65	15	0,5	5	LC..1605..

Initial plunge (INPLM/INPLX) relates to face groove diameter, see page(s) 477.

**Max depth of cut for LCGF/LCMF16.. = 14 mm

Spare Parts, Parts included in delivery

For holder	Clamp key	Clamp screw	Torque value Nm
CFIR/L...05	5SMS795	TCEI0613	8,0

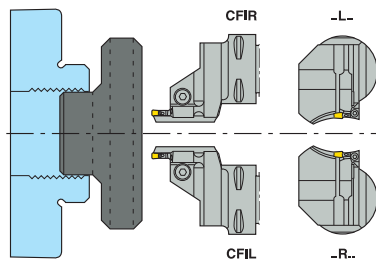

Please check availability in current price and stock-list

Toolholders for inserts LCGF, LCGN, LCMF and LCMR



• For insert programme, see page(s) 578-583, 593-594

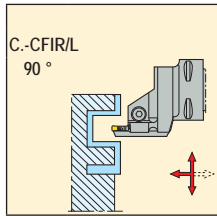
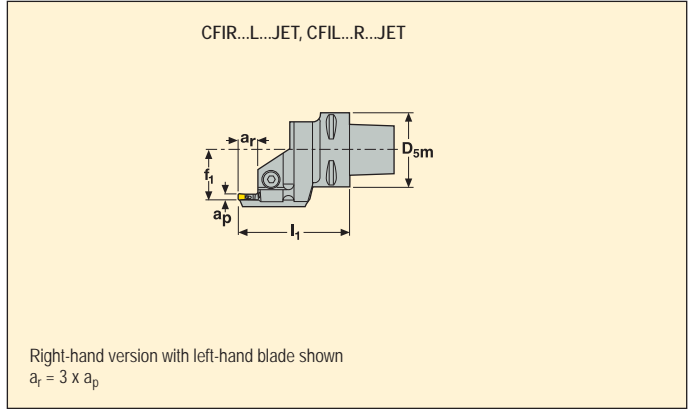

Capto size	Part No.	Dimensions in mm							KG	Seat size	Image		
		INPLM	INPLX	D _{sm}	f ₁	I ₁	a _r						
C5	3	C5-CFIR -35060-03L080055-JET	55	80	50	35,0	60	9	0,7	3	LC..1603..		
		-35060-03L100070-JET	70	100	50	35,0	60	9	0,7	3	LC..1603..		
		-35060-03L130090-JET	90	130	50	35,0	60	9	0,7	3	LC..1603..		
		-35060-03L170110-JET	110	170	50	35,0	60	9	0,7	3	LC..1603..		
		C5-CFIL -35060-03R080055-JET	55	80	50	35,0	60	9	0,7	3	LC..1603..		
		-35060-03R100070-JET	70	100	50	35,0	60	9	0,7	3	LC..1603..		
		-35060-03R130090-JET	90	130	50	35,0	60	9	0,7	3	LC..1603..		
		-35060-03R170110-JET	110	170	50	35,0	60	9	0,7	3	LC..1603..		
		4	4	C5-CFIR -35065-04L080055-JET	55	80	50	35,0	65	12	0,7	4	LC..1604..
				-35065-04L100070-JET	70	100	50	35,0	65	12	0,7	4	LC..1604..
-35065-04L130090-JET	90			130	50	35,0	65	12	0,7	4	LC..1604..		
-35065-04L170110-JET	110			170	50	35,0	65	12	0,7	4	LC..1604..		
-35065-04L230140-JET	140			230	50	35,0	65	12	0,7	4	LC..1604..		
C5-CFIL -35065-04R080055-JET	55			80	50	35,0	65	12	0,7	4	LC..1604..		
-35065-04R100070-JET	70			100	50	35,0	65	12	0,7	4	LC..1604..		
-35065-04R130090-JET	90			130	50	35,0	65	12	0,7	4	LC..1604..		
-35065-04R170110-JET	110			170	50	35,0	65	12	0,7	4	LC..1604..		
-35065-04R230140-JET	140			230	50	35,0	65	12	0,7	4	LC..1604..		

Initial plunge (INPLM/INPLX) relates to face groove diameter, see page(s) 477.

Spare Parts, Parts included in delivery

For holder	Clamp key	Clamp screw	Torque value Nm
CFIR/L...-03	4SMS795	TCEI0513	6,0
CFIR/L...-04	5SMS795	TCEI0613	8,0

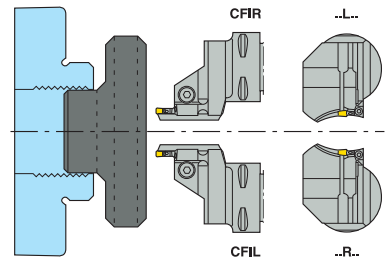

Please check availability in current price and stock-list

Toolholders for inserts LCGF, LCGN, LCMF and LCMR



- For insert programme, see page(s) 578-583, 593-594

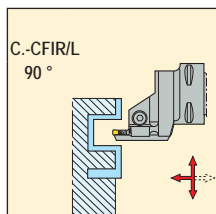
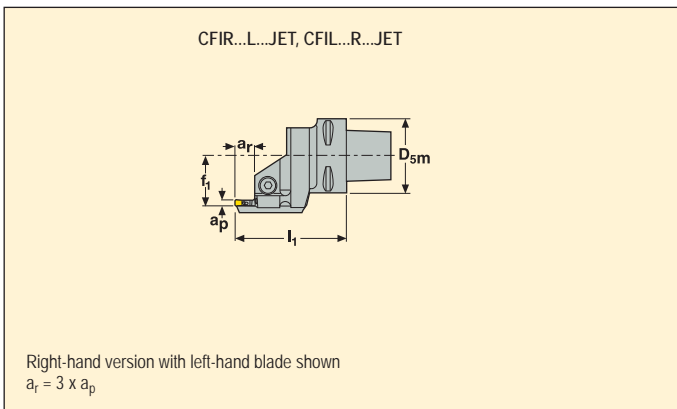

Capto size	Part No.	Dimensions in mm							KG	Seat size	Insert
		INPLM	INPLX	D _{5m}	f ₁	l ₁	a _r **				
C5	5	C5-CFIR -35065-05L080055-JET	55	80	50	35,0	65	15	0,7	5	LC..1605..
		-35065-05L100070-JET	70	100	50	35,0	65	15	0,7	5	LC..1605..
		-35065-05L130090-JET	90	130	50	35,0	65	15	0,7	5	LC..1605..
		-35065-05L170110-JET	110	170	50	35,0	65	15	0,7	5	LC..1605..
		-35065-05L230140-JET	140	230	50	35,0	65	15	0,7	5	LC..1605..
		C5-CFIL -35065-05R080055-JET	55	80	50	35,0	65	15	0,7	5	LC..1605..
		-35065-05R100070-JET	70	100	50	35,0	65	15	0,7	5	LC..1605..
		-35065-05R130090-JET	90	130	50	35,0	65	15	0,7	5	LC..1605..
		-35065-05R170110-JET	110	170	50	35,0	65	15	0,7	5	LC..1605..
		-35065-05R230140-JET	140	230	50	35,0	65	15	0,7	5	LC..1605..
C5	6	C5-CFIR -35075-06L080055-JET	55	80	50	35,0	75	18	0,8	6	LC..1606..
		-35075-06L100070-JET	70	100	50	35,0	75	18	0,8	6	LC..1606..
		-35075-06L130090-JET	90	130	50	35,0	75	18	0,8	6	LC..1606..
		-35075-06L170110-JET	110	170	50	35,0	75	18	0,8	6	LC..1606..
		-35075-06L230140-JET	140	230	50	35,0	75	18	0,8	6	LC..1606..
		C5-CFIL -35075-06R080055-JET	55	80	50	35,0	75	18	0,8	6	LC..1606..
		-35075-06R100070-JET	70	100	50	35,0	75	18	0,8	6	LC..1606..
		-35075-06R130090-JET	90	130	50	35,0	75	18	0,8	6	LC..1606..
		-35075-06R170110-JET	110	170	50	35,0	75	18	0,8	6	LC..1606..
		-35075-06R230140-JET	140	230	50	35,0	75	18	0,8	6	LC..1606..

Initial plunge (INPLM/INPLX) relates to face groove diameter, see page(s) 477.

**Max depth of cut for LCGF/LCMF16.. = 14 mm

Spare Parts, Parts included in delivery

For holder	Clamp key	Clamp screw	Torque value Nm
CFIR/L...05	5SMS795	TCEI0613	8,0
CFIR/L...06	6SMS795	TCEI0815	10,0

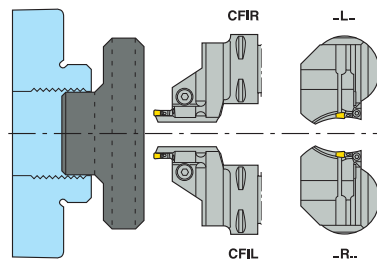

Please check availability in current price and stock-list

Toolholders for inserts LCGF, LCGN, LCMF and LCMR



• For insert programme, see page(s) 578-583, 593-594

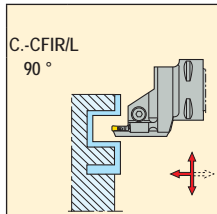
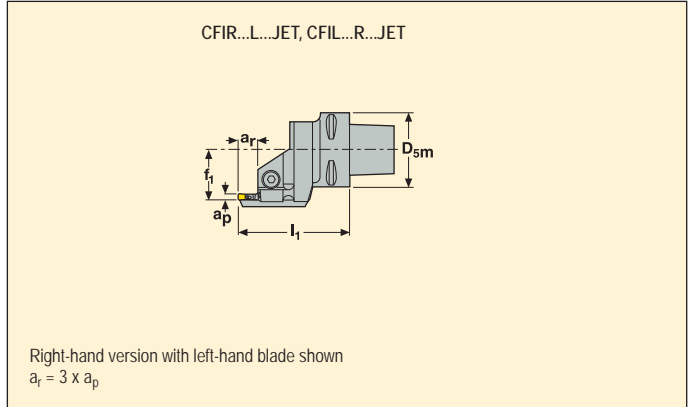

Capto size	Part No.	Dimensions in mm							KG	Seat size	Image	
		INPLM	INPLX	D _{sm}	f ₁	l ₁	a _r					
C6	3	C6-CFIR -45065-03L080055-JET	55	80	63	45,0	65	9	1,1	3	LC..1603..	
		-45065-03L100070-JET	70	100	63	45,0	65	9	1,1	3	LC..1603..	
		-45065-03L130090-JET	90	130	63	45,0	65	9	1,1	3	LC..1603..	
		-45065-03L170110-JET	110	170	63	45,0	65	9	1,1	3	LC..1603..	
		C6-CFIL -45065-03R080055-JET	55	80	63	45,0	65	9	1,1	3	LC..1603..	
		-45065-03R100070-JET	70	100	63	45,0	65	9	1,1	3	LC..1603..	
	4	4	C6-CFIR -45065-04L080055-JET	55	80	63	45,0	65	12	1,1	4	LC..1604..
			-45065-04L100070-JET	70	100	63	45,0	65	12	1,1	4	LC..1604..
			-45065-04L130090-JET	90	130	63	45,0	65	12	1,1	4	LC..1604..
			-45065-04L170110-JET	110	170	63	45,0	65	12	1,1	4	LC..1604..
			-45065-04L230140-JET	140	230	63	45,0	65	12	1,1	4	LC..1604..
			C6-CFIL -45065-04R080055-JET	55	80	63	45,0	65	12	1,1	4	LC..1604..
-45065-04R100070-JET	70	100	63	45,0	65	12	1,1	4	LC..1604..			
-45065-04R130090-JET	90	130	63	45,0	65	12	1,1	4	LC..1604..			
-45065-04R170110-JET	110	170	63	45,0	65	12	1,1	4	LC..1604..			
-45065-04R230140-JET	140	230	63	45,0	65	12	1,1	4	LC..1604..			

Initial plunge (INPLM/INPLX) relates to face groove diameter, see page(s) 477.

Spare Parts, Parts included in delivery

For holder	Clamp key	Clamp screw	Torque value Nm
CFIR/L...-03	4SMS795	TCEI0513	6,0
CFIR/L...-04	5SMS795	TCEI0613	8,0

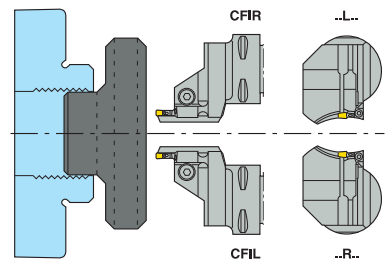

Please check availability in current price and stock-list

Toolholders for inserts LCGF, LCGN, LCMF and LCMR



- For insert programme, see page(s) 578-583, 593-594

CFIR...L...JET, CFIL...R...JET

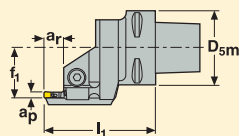

Right-hand version with left-hand blade shown

$$a_r = 3 \times a_p$$

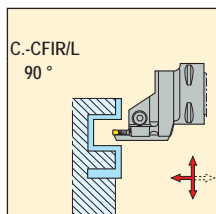

Capto size	Part No.	Dimensions in mm							KG	Seat size	Insert
		INPLM	INPLX	D _{5m}	f ₁	l ₁	a _r **				
C6	5	C6-CFIR -45070-05L080055-JET	55	80	63	45,0	70	15	1,1	5	LC..1605..
		-45070-05L100070-JET	70	100	63	45,0	70	15	1,1	5	LC..1605..
		-45070-05L130090-JET	90	130	63	45,0	70	15	1,1	5	LC..1605..
		-45070-05L170110-JET	110	170	63	45,0	70	15	1,1	5	LC..1605..
		-45070-05L230140-JET	140	230	63	45,0	70	15	1,1	5	LC..1605..
	6	C6-CFIL -45070-05R080055-JET	55	80	63	45,0	70	15	1,1	5	LC..1605..
		-45070-05R100070-JET	70	100	63	45,0	70	15	1,1	5	LC..1605..
		-45070-05R130090-JET	90	130	63	45,0	70	15	1,1	5	LC..1605..
		-45070-05R170110-JET	110	170	63	45,0	70	15	1,1	5	LC..1605..
		-45070-05R230140-JET	140	230	63	45,0	70	15	1,1	5	LC..1605..
C6	5	C6-CFIR -45075-06L080055-JET	55	80	63	45,0	75	18	1,1	6	LC..1606..
		-45075-06L100070-JET	70	100	63	45,0	75	18	1,1	6	LC..1606..
		-45075-06L130090-JET	90	130	63	45,0	75	18	1,1	6	LC..1606..
		-45075-06L170110-JET	110	170	63	45,0	75	18	1,1	6	LC..1606..
		-45075-06L230140-JET	140	230	63	45,0	75	18	1,1	6	LC..1606..
	6	C6-CFIL -45075-06R080055-JET	55	80	63	45,0	75	18	1,1	6	LC..1606..
		-45075-06R100070-JET	70	100	63	45,0	75	18	1,1	6	LC..1606..
		-45075-06R130090-JET	90	130	63	45,0	75	18	1,1	6	LC..1606..
		-45075-06R170110-JET	110	170	63	45,0	75	18	1,1	6	LC..1606..
		-45075-06R230140-JET	140	230	63	45,0	75	18	1,1	6	LC..1606..

Initial plunge (INPLM/INPLX) relates to face groove diameter, see page(s) 477.

**Max depth of cut for LCGF/LCMF16.. = 14 mm

Spare Parts, Parts included in delivery

For holder	Clamp key	Clamp screw	Torque value Nm
CFIR/L...-05	5SMS795	TCEI0613	8,0
CFIR/L...-06	6SMS795	TCEI0815	10,0

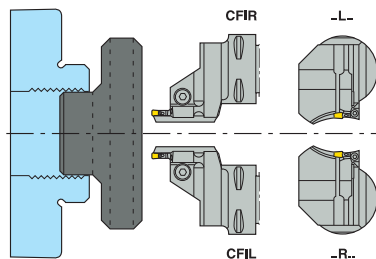

Please check availability in current price and stock-list

Toolholders for inserts LCGF, LCGN, LCMF and LCMR



• For insert programme, see page(s) 578, 581-583

CFIR...L...JET, CFIL...R...JET

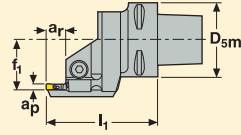

Right-hand version with left-hand blade shown
 $a_r = 3 \times a_p$

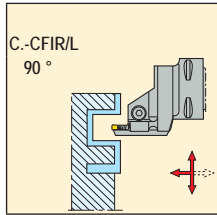

Capto size	Part No.	Dimensions in mm							KG	Seat size	
		INPLM	INPLX	D _{5m}	f ₁	l ₁	a _r				
C6	8	C6-CFIR -45085-08L130090-JET	90	130	63	45,0	85	24	1,2	8	LC..3008..
		-45085-08L170110-JET	110	170	63	45,0	85	24	1,2	8	LC..3008..
		-45085-08L230140-JET	140	230	63	45,0	85	24	1,2	8	LC..3008..
		-45085-08L500200-JET	200	500	63	45,0	85	24	1,2	8	LC..3008..
		C6-CFIL -45085-08R130090-JET	90	130	63	45,0	85	24	1,2	8	LC..3008..
		-45085-08R170110-JET	110	170	63	45,0	85	24	1,2	8	LC..3008..
		-45085-08R230140-JET	140	230	63	45,0	85	24	1,2	8	LC..3008..
		-45085-08R500200-JET	200	500	63	45,0	85	24	1,2	8	LC..3008..

Initial plunge (INPLM/INPLX) relates to face groove diameter, see page(s) 477.

Spare Parts, Parts included in delivery

For holder	Clamp key	Clamp screw	Torque value Nm
CFIR/L...08	6SMS795	TCEI1020	15,0

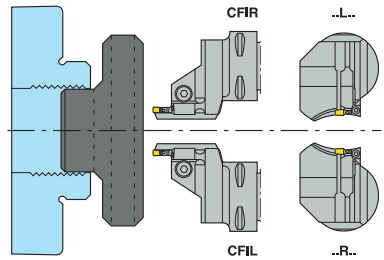

Please check availability in current price and stock-list

Toolholders for inserts LCGF, LCGN, LCMF and LCMR



• For insert programme, see page(s) 578-583, 593-594

CFOR...L...JET, CFOL...R...JET

Right-hand version with left-hand blade shown
 $a_r = 6 \times a_p$

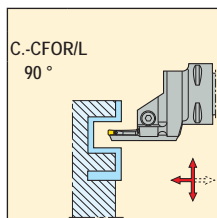

Capto size	Part No.	Dimensions in mm						KG	Seat size	Insert		
		INPLM	INPLX	D _{5m}	f ₁	l ₁	a _r **					
C4	3	C4-CFOR -27070-03L080055-JET	55	80	40	27,0	70	18	0,5	3	LC..1603..	
		-27070-03L100070-JET	70	100	40	27,0	70	18	0,5	3	LC..1603..	
		-27070-03L130090-JET	90	130	40	27,0	70	18	0,5	3	LC..1603..	
		-27070-03L170110-JET	110	170	40	27,0	70	18	0,5	3	LC..1603..	
		-27070-03L230140-JET	140	230	40	27,0	70	18	0,5	3	LC..1603..	
		-27070-03L500200-JET	200	500	40	27,0	70	18	0,5	3	LC..1603..	
	4	C4-CFOL	-27070-03R080055-JET	55	80	40	27,0	70	18	0,5	3	LC..1603..
			-27070-03R100070-JET	70	100	40	27,0	70	18	0,5	3	LC..1603..
			-27070-03R130090-JET	90	130	40	27,0	70	18	0,5	3	LC..1603..
			-27070-03R170110-JET	110	170	40	27,0	70	18	0,5	3	LC..1603..
			-27070-03R230140-JET	140	230	40	27,0	70	18	0,5	3	LC..1603..
			-27070-03R500200-JET	200	500	40	27,0	70	18	0,5	3	LC..1603..
C4	3	C4-CFOR -27080-04L080055-JET	55	80	40	27,0	80	24	0,5	4	LC..1604..	
		-27080-04L100070-JET	70	100	40	27,0	80	24	0,5	4	LC..1604..	
		-27080-04L130090-JET	90	130	40	27,0	80	24	0,5	4	LC..1604..	
		-27080-04L170110-JET	110	170	40	27,0	80	24	0,5	4	LC..1604..	
		-27080-04L230140-JET	140	230	40	27,0	80	24	0,5	4	LC..1604..	
		-27080-04L500200-JET	200	500	40	27,0	80	24	0,5	4	LC..1604..	
	4	C4-CFOL	-27080-04R080055-JET	55	80	40	27,0	80	24	0,5	4	LC..1604..
			-27080-04R100070-JET	70	100	40	27,0	80	24	0,5	4	LC..1604..
			-27080-04R130090-JET	90	130	40	27,0	80	24	0,5	4	LC..1604..
			-27080-04R170110-JET	110	170	40	27,0	80	24	0,5	4	LC..1604..
			-27080-04R230140-JET	140	230	40	27,0	80	24	0,5	4	LC..1604..
			-27080-04R500200-JET	200	500	40	27,0	80	24	0,5	4	LC..1604..

Initial plunge (INPLM/INPLX) relates to face groove diameter, see page(s) 477.

**Max depth of cut for LCGF/LCMF16.. = 14 mm

Spare Parts, Parts included in delivery

For holder	Clamp key	Clamp screw	Torque value Nm
CFOR/L...03	4SMS795	TCEI0513	6,0
CFOR/L...04	5SMS795	TCEI0613	8,0

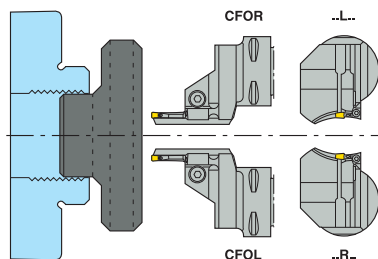

Please check availability in current price and stock-list

Toolholders for inserts LCGF, LCGN, LCMF and LCMR



• For insert programme, see page(s) 578-583, 593-594

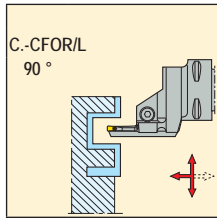
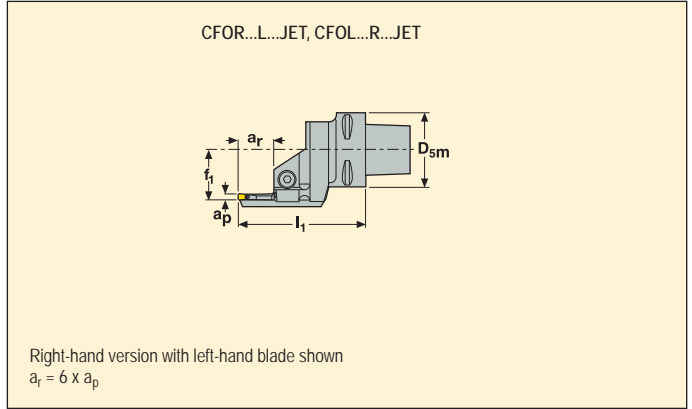

Capto size	Part No.	Dimensions in mm						KG	Seat size	Insert		
		INPLM	INPLX	D _{sm}	f ₁	l ₁	a _r **					
C4	5	C4-CFOR -27085-05L080055-JET	55	80	40	27,0	85	30	0,5	5	LC..1605..	
		-27085-05L100070-JET	70	100	40	27,0	85	30	0,5	5	LC..1605..	
		-27085-05L130090-JET	90	130	40	27,0	85	30	0,5	5	LC..1605..	
		-27085-05L170110-JET	110	170	40	27,0	85	30	0,5	5	LC..1605..	
		-27085-05L230140-JET	140	230	40	27,0	85	30	0,5	5	LC..1605..	
		-27085-05L500200-JET	200	500	40	27,0	85	30	0,5	5	LC..1605..	
		C4-CFOL -27085-05R080055-JET	55	80	40	27,0	85	30	0,5	5	LC..1605..	
		-27085-05R100070-JET	70	100	40	27,0	85	30	0,5	5	LC..1605..	
		-27085-05R130090-JET	90	130	40	27,0	85	30	0,5	5	LC..1605..	
		-27085-05R170110-JET	110	170	40	27,0	85	30	0,5	5	LC..1605..	
		-27085-05R230140-JET	140	230	40	27,0	85	30	0,5	5	LC..1605..	
		-27085-05R500200-JET	200	500	40	27,0	85	30	0,5	5	LC..1605..	

Initial plunge (INPLM/INPLX) relates to face groove diameter, see page(s) 477.

**Max depth of cut for LCGF/LCMF16.. = 14 mm

Spare Parts, Parts included in delivery

For holder	Clamp key	Clamp screw	Torque value Nm
CFOR/L...05	5SMS795	TCEI0613	8,0

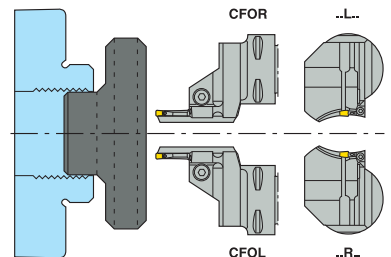

Please check availability in current price and stock-list

Toolholders for inserts LCGF, LCGN, LCMF and LCMR



• For insert programme, see page(s) 578-583, 593-594

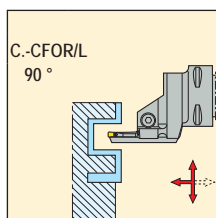
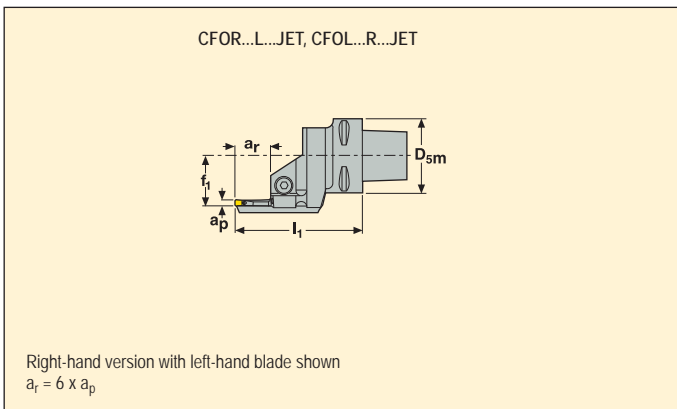

Capto size	Part No.	Dimensions in mm						KG	Seat size	Insert	
		INPLM	INPLX	D _{5m}	f ₁	l ₁	a _r **				
C5	3	C5-CFOR -35070-03L080055-JET	55	80	50	35,0	70	18	0,7	3	LC..1603..
		C5-CFOR -35070-03L100070-JET	70	100	50	35,0	70	18	0,7	3	LC..1603..
		C5-CFOR -35070-03L130090-JET	90	130	50	35,0	70	18	0,7	3	LC..1603..
		C5-CFOR -35070-03L170110-JET	110	170	50	35,0	70	18	0,7	3	LC..1603..
		C5-CFOR -35070-03L230140-JET	140	230	50	35,0	70	18	0,7	3	LC..1603..
		C5-CFOR -35070-03L500200-JET	200	500	50	35,0	70	18	0,7	3	LC..1603..
	4	C5-CFOR -35080-04L080055-JET	55	80	50	35,0	80	24	0,8	4	LC..1604..
		C5-CFOR -35080-04L100070-JET	70	100	50	35,0	80	24	0,8	4	LC..1604..
		C5-CFOR -35080-04L130090-JET	90	130	50	35,0	80	24	0,8	4	LC..1604..
		C5-CFOR -35080-04L170110-JET	110	170	50	35,0	80	24	0,8	4	LC..1604..
		C5-CFOR -35080-04L230140-JET	140	230	50	35,0	80	24	0,8	4	LC..1604..
		C5-CFOR -35080-04L500200-JET	200	500	50	35,0	80	24	0,8	4	LC..1604..
3	C5-CFOL -35070-03R080055-JET	55	80	50	35,0	70	18	0,7	3	LC..1603..	
	C5-CFOL -35070-03R100070-JET	70	100	50	35,0	70	18	0,7	3	LC..1603..	
	C5-CFOL -35070-03R130090-JET	90	130	50	35,0	70	18	0,7	3	LC..1603..	
	C5-CFOL -35070-03R170110-JET	110	170	50	35,0	70	18	0,7	3	LC..1603..	
	C5-CFOL -35070-03R230140-JET	140	230	50	35,0	70	18	0,7	3	LC..1603..	
	C5-CFOL -35070-03R500200-JET	200	500	50	35,0	70	18	0,7	3	LC..1603..	
4	C5-CFOL -35080-04R080055-JET	55	80	50	35,0	80	24	0,8	4	LC..1604..	
	C5-CFOL -35080-04R100070-JET	70	100	50	35,0	80	24	0,8	4	LC..1604..	
	C5-CFOL -35080-04R130090-JET	90	130	50	35,0	80	24	0,8	4	LC..1604..	
	C5-CFOL -35080-04R170110-JET	110	170	50	35,0	80	24	0,8	4	LC..1604..	
	C5-CFOL -35080-04R230140-JET	140	230	50	35,0	80	24	0,8	4	LC..1604..	
	C5-CFOL -35080-04R500200-JET	200	500	50	35,0	80	24	0,8	4	LC..1604..	

Initial plunge (INPLM/INPLX) relates to face groove diameter, see page(s) 477.

**Max depth of cut for LCGF/LCMF16.. = 14 mm

Spare Parts, Parts included in delivery

For holder	Clamp key	Clamp screw	Torque value Nm
CFOR/L...03	4SMS795	TCEI0513	6,0
CFOR/L...04	5SMS795	TCEI0613	8,0

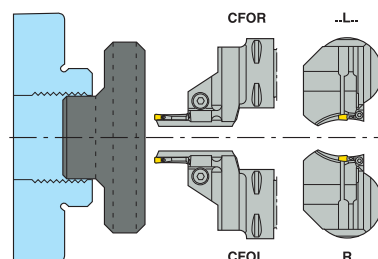

Please check availability in current price and stock-list

Toolholders for inserts LCGF, LCGN, LCMF and LCMR



• For insert programme, see page(s) 578-583, 593-594

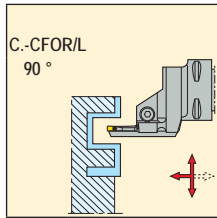
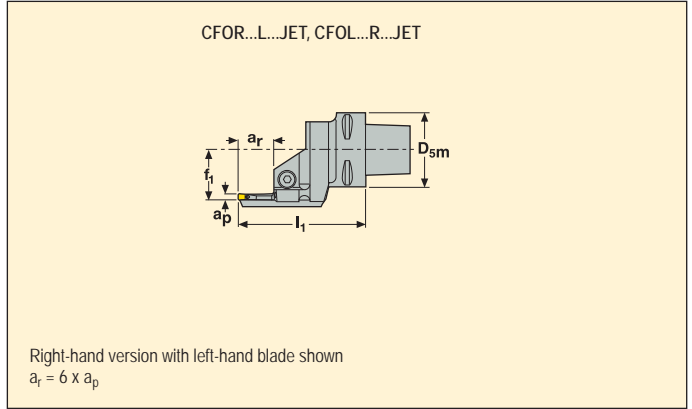

Capto size	Part No.	Dimensions in mm						KG	Seat size	Insert		
		INPLM	INPLX	D _{sm}	f ₁	l ₁	a _r **					
C5	5	C5-CFOR -35085-05L080055-JET	55	80	50	35,0	85	30	0,8	5	LC..1605..	
		-35085-05L100070-JET	70	100	50	35,0	85	30	0,8	5	LC..1605..	
		-35085-05L130090-JET	90	130	50	35,0	85	30	0,8	5	LC..1605..	
		-35085-05L170110-JET	110	170	50	35,0	85	30	0,8	5	LC..1605..	
		-35085-05L230140-JET	140	230	50	35,0	85	30	0,8	5	LC..1605..	
		-35085-05L500200-JET	200	500	50	35,0	85	30	0,8	5	LC..1605..	
	5	C5-CFOL	-35085-05R080055-JET	55	80	50	35,0	85	30	0,8	5	LC..1605..
			-35085-05R100070-JET	70	100	50	35,0	85	30	0,8	5	LC..1605..
			-35085-05R130090-JET	90	130	50	35,0	85	30	0,8	5	LC..1605..
			-35085-05R170110-JET	110	170	50	35,0	85	30	0,8	5	LC..1605..
			-35085-05R230140-JET	140	230	50	35,0	85	30	0,8	5	LC..1605..
			-35085-05R500200-JET	200	500	50	35,0	85	30	0,8	5	LC..1605..
6	C5-CFOR	-35100-06L080055-JET	55	80	50	35,0	100	36	1,0	6	LC..1606..	
		-35100-06L100070-JET	70	100	50	35,0	100	36	1,0	6	LC..1606..	
		-35100-06L130090-JET	90	130	50	35,0	100	36	1,0	6	LC..1606..	
		-35100-06L170110-JET	110	170	50	35,0	100	36	1,0	6	LC..1606..	
		-35100-06L230140-JET	140	230	50	35,0	100	36	1,0	6	LC..1606..	
		-35100-06L500200-JET	200	500	50	35,0	100	36	1,0	6	LC..1606..	
	6	C5-CFOL	-35100-06R080055-JET	55	80	50	35,0	100	36	1,0	6	LC..1606..
			-35100-06R100070-JET	70	100	50	35,0	100	36	1,0	6	LC..1606..
			-35100-06R130090-JET	90	130	50	35,0	100	36	1,0	6	LC..1606..
			-35100-06R170110-JET	110	170	50	35,0	100	36	1,0	6	LC..1606..
			-35100-06R230140-JET	140	230	50	35,0	100	36	1,0	6	LC..1606..
			-35100-06R500200-JET	200	500	50	35,0	100	36	1,0	6	LC..1606..

Initial plunge (INPLM/INPLX) relates to face groove diameter, see page(s) 477.

**Max depth of cut for LCGF/LCMF16.. = 14 mm

Spare Parts, Parts included in delivery

For holder	Clamp key	Clamp screw	Torque value Nm
CFOR/L...05	5SMS795	TCEI0613	8,0
CFOR/L...06	6SMS795	TCEI0815	10,0

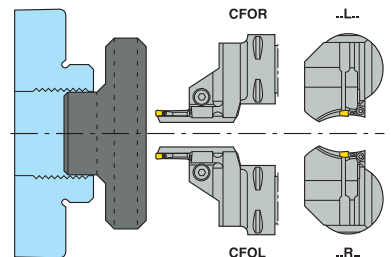

Please check availability in current price and stock-list

Toolholders for inserts LCGF, LCGN, LCMF and LCMR



• For insert programme, see page(s) 578-583, 593-594

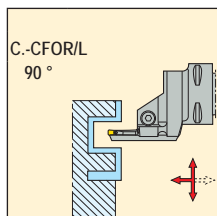
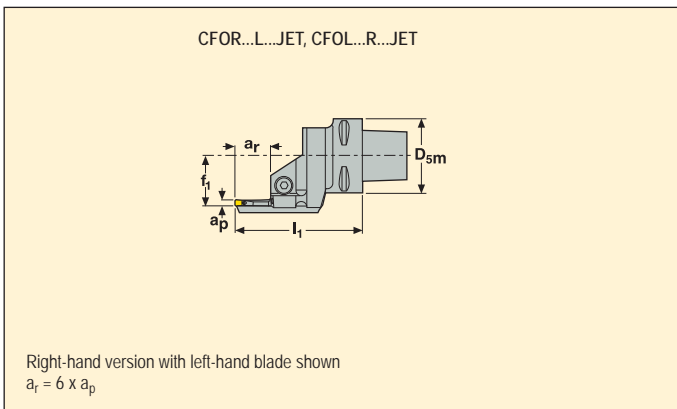

Capto size	Part No.	Dimensions in mm						KG	Seat size	Insert	
		INPLM	INPLX	D _{5m}	f ₁	l ₁	a _r **				
C6	3	C6-CFOR -45075-03L080055-JET	55	80	63	45,0	75	18	1,2	3	LC..1603..
		C6-CFOR -45075-03L100070-JET	70	100	63	45,0	75	18	1,2	3	LC..1603..
		C6-CFOR -45075-03L130090-JET	90	130	63	45,0	75	18	1,2	3	LC..1603..
		C6-CFOR -45075-03L170110-JET	110	170	63	45,0	75	18	1,2	3	LC..1603..
		C6-CFOR -45075-03L230140-JET	140	230	63	45,0	75	18	1,2	3	LC..1603..
		C6-CFOR -45075-03L500200-JET	200	500	63	45,0	75	18	1,2	3	LC..1603..
	3	C6-CFOL -45075-03R080055-JET	55	80	63	45,0	75	18	1,2	3	LC..1603..
		C6-CFOL -45075-03R100070-JET	70	100	63	45,0	75	18	1,2	3	LC..1603..
		C6-CFOL -45075-03R130090-JET	90	130	63	45,0	75	18	1,2	3	LC..1603..
		C6-CFOL -45075-03R170110-JET	110	170	63	45,0	75	18	1,2	3	LC..1603..
		C6-CFOL -45075-03R230140-JET	140	230	63	45,0	75	18	1,2	3	LC..1603..
		C6-CFOL -45075-03R500200-JET	200	500	63	45,0	75	18	1,2	3	LC..1603..
4	C6-CFOR	C6-CFOR -45080-04L080055-JET	55	80	63	45,0	80	24	1,2	4	LC..1604..
		C6-CFOR -45080-04L100070-JET	70	100	63	45,0	80	24	1,2	4	LC..1604..
		C6-CFOR -45080-04L130090-JET	90	130	63	45,0	80	24	1,2	4	LC..1604..
		C6-CFOR -45080-04L170110-JET	110	170	63	45,0	80	24	1,2	4	LC..1604..
		C6-CFOR -45080-04L230140-JET	140	230	63	45,0	80	24	1,2	4	LC..1604..
		C6-CFOR -45080-04L500200-JET	200	500	63	45,0	80	24	1,2	4	LC..1604..
	C6-CFOL	C6-CFOL -45080-04R080055-JET	55	80	63	45,0	80	24	1,2	4	LC..1604..
		C6-CFOL -45080-04R100070-JET	70	100	63	45,0	80	24	1,2	4	LC..1604..
		C6-CFOL -45080-04R130090-JET	90	130	63	45,0	80	24	1,2	4	LC..1604..
		C6-CFOL -45080-04R170110-JET	110	170	63	45,0	80	24	1,2	4	LC..1604..
		C6-CFOL -45080-04R230140-JET	140	230	63	45,0	80	24	1,2	4	LC..1604..
		C6-CFOL -45080-04R500200-JET	200	500	63	45,0	80	24	1,2	4	LC..1604..

Initial plunge (INPLM/INPLX) relates to face groove diameter, see page(s) 477.

**Max depth of cut for LCGF/LCMF16.. = 14 mm

Spare Parts, Parts included in delivery

For holder	Clamp key	Clamp screw	Torque value Nm
CFOR/L...03	4SMS795	TCEI0513	6,0
CFOR/L...04	5SMS795	TCEI0613	8,0

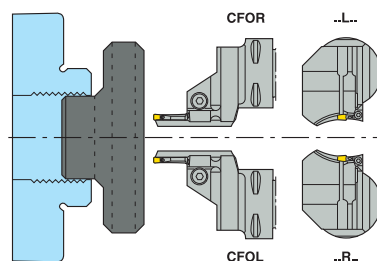

Please check availability in current price and stock-list

Toolholders for inserts LCGF, LCGN, LCMF and LCMR



• For insert programme, see page(s) 578-583, 593-594

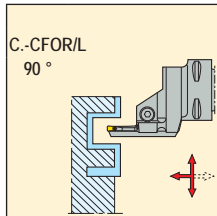
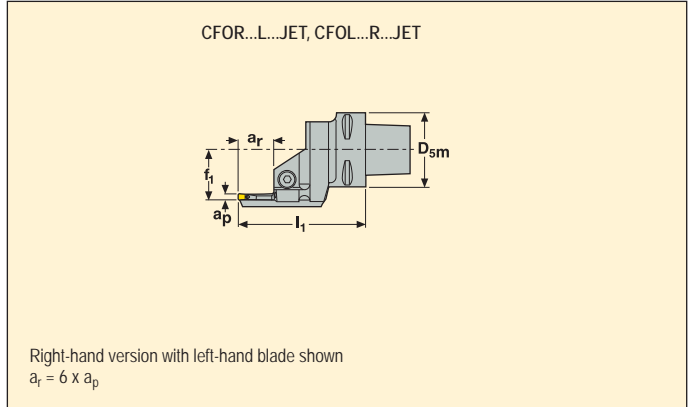

Capto size	Part No.	Dimensions in mm							KG	Seat size	Image	
		INPLM	INPLX	D _{sm}	f ₁	l ₁	a _r **					
C6	5	C6-CFOR -45090-05L080055-JET	55	80	63	45,0	90	30	1,2	5	LC..1605..	
		-45090-05L100070-JET	70	100	63	45,0	90	30	1,2	5	LC..1605..	
		-45090-05L130090-JET	90	130	63	45,0	90	30	1,2	5	LC..1605..	
		-45090-05L170110-JET	110	170	63	45,0	90	30	1,2	5	LC..1605..	
		-45090-05L230140-JET	140	230	63	45,0	90	30	1,2	5	LC..1605..	
		-45090-05L500200-JET	200	500	63	45,0	90	30	1,2	5	LC..1605..	
	6	C6-CFOR	-45090-05R080055-JET	55	80	63	45,0	90	30	1,2	5	LC..1605..
			-45090-05R100070-JET	70	100	63	45,0	90	30	1,2	5	LC..1605..
			-45090-05R130090-JET	90	130	63	45,0	90	30	1,2	5	LC..1605..
			-45090-05R170110-JET	110	170	63	45,0	90	30	1,2	5	LC..1605..
		C6-CFOL	-45090-05R230140-JET	140	230	63	45,0	90	30	1,2	5	LC..1605..
			-45090-05R500200-JET	200	500	63	45,0	90	30	1,2	5	LC..1605..
			-45100-06L080055-JET	55	80	63	45,0	100	36	1,3	6	LC..1606..
			-45100-06L100070-JET	70	100	63	45,0	100	36	1,3	6	LC..1606..
6	C6-CFOR	-45100-06L130090-JET	90	130	63	45,0	100	36	1,3	6	LC..1606..	
		-45100-06L170110-JET	110	170	63	45,0	100	36	1,3	6	LC..1606..	
		-45100-06L230140-JET	140	230	63	45,0	100	36	1,3	6	LC..1606..	
		-45100-06L500200-JET	200	500	63	45,0	100	36	1,3	6	LC..1606..	
	C6-CFOL	-45100-06R080055-JET	55	80	63	45,0	100	36	1,3	6	LC..1606..	
		-45100-06R100070-JET	70	100	63	45,0	100	36	1,3	6	LC..1606..	
		-45100-06R130090-JET	90	130	63	45,0	100	36	1,3	6	LC..1606..	
		-45100-06R170110-JET	110	170	63	45,0	100	36	1,3	6	LC..1606..	
6	C6-CFOR	-45100-06R230140-JET	140	230	63	45,0	100	36	1,3	6	LC..1606..	
		-45100-06R500200-JET	200	500	63	45,0	100	36	1,3	6	LC..1606..	

Initial plunge (INPLM/INPLX) relates to face groove diameter, see page(s) 477.

**Max depth of cut for LCGF/LCMF16.. = 14 mm

Spare Parts, Parts included in delivery

For holder	Clamp key	Clamp screw	Torque value Nm
CFOR/L...05	5SMS795	TCEI0613	8,0
CFOR/L...06	6SMS795	TCEI0815	10,0

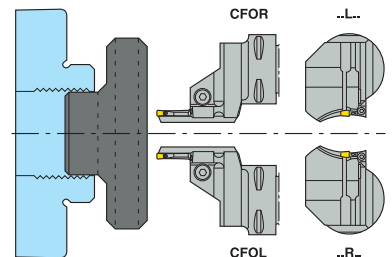

Please check availability in current price and stock-list

MDT – Toolholders, ext. axial, Jetstream Tooling®, Seco-Capto™ SECO

Toolholders for inserts LCGF, LCGN, LCMF and LCMR



• For insert programme, see page(s) 578, 581-583

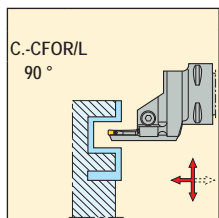
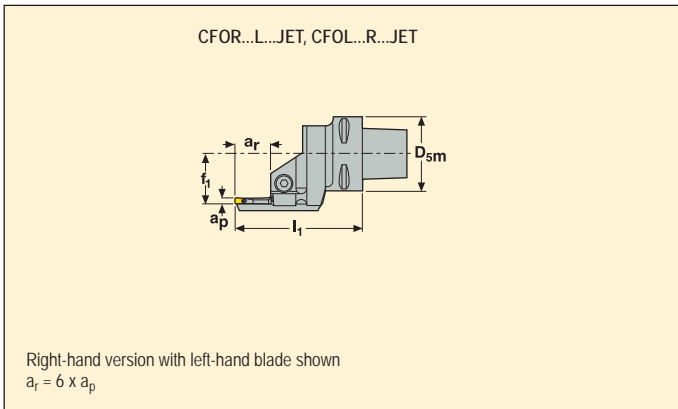

Capto size	Part No.	Dimensions in mm						KG	Seat size	Insert	
		INPLM	INPLX	D _{5m}	f ₁	l ₁	a _r **				
C6	8	C6-CFOR-45115-08L130090-JET	90	130	63	45,0	115	48	1,4	8	LC..3008..
		C6-CFOR-45115-08L170110-JET	110	170	63	45,0	115	48	1,4	8	LC..3008..
		C6-CFOR-45115-08L230140-JET	140	230	63	45,0	115	48	1,4	8	LC..3008..
		C6-CFOR-45115-08L500200-JET	200	500	63	45,0	115	48	1,4	8	LC..3008..
	8	C6-CFOL-45115-08R130090-JET	90	130	63	45,0	115	48	1,4	8	LC..3008..
		C6-CFOL-45115-08R170110-JET	110	170	63	45,0	115	48	1,4	8	LC..3008..
		C6-CFOL-45115-08R230140-JET	140	230	63	45,0	115	48	1,4	8	LC..3008..
		C6-CFOL-45115-08R500200-JET	200	500	63	45,0	115	48	1,4	8	LC..3008..

Initial plunge (INPLM/INPLX) relates to face groove diameter, see page(s) 477.

**Max depth of cut for LCGF/LCMF30.. = 28 mm

Spare Parts, Parts included in delivery

For holder	Clamp key	Clamp screw	Torque value Nm
CFOR/L..08	6SMS795	TCEI1020	15,0

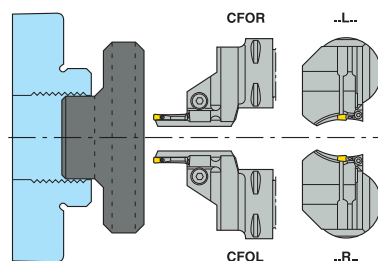

Please check availability in current price and stock-list

Toolholders for inserts LCGF, LCGN, LCMF and LCMR



• For insert programme, see page(s) 578-583, 593-594

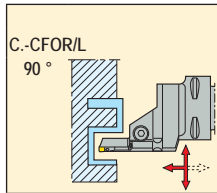
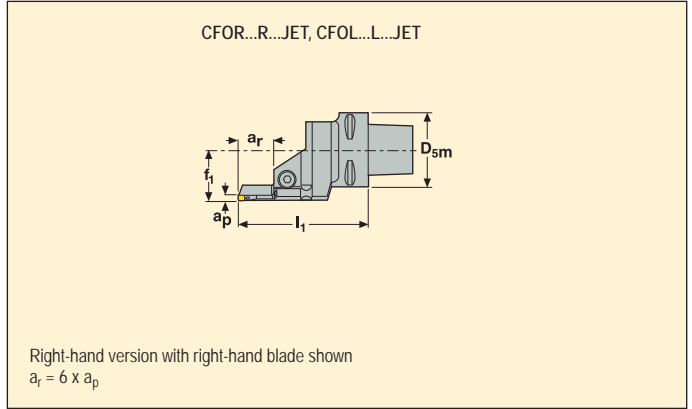

Capto size	Part No.	Dimensions in mm						KG	Seat size	Insert	
		INPLM	INPLX	D _{sm}	f ₁	I ₁	a _r **				
C4	3	C4-CFOR -27070-03R080055-JET	55	80	40	27,0	70	18	0,5	3	LC..1603..
		-27070-03R100070-JET	70	100	40	27,0	70	18	0,5	3	LC..1603..
		-27070-03R130090-JET	90	130	40	27,0	70	18	0,5	3	LC..1603..
		-27070-03R170110-JET	110	170	40	27,0	70	18	0,5	3	LC..1603..
		-27070-03R230140-JET	140	230	40	27,0	70	18	0,5	3	LC..1603..
		-27070-03R500200-JET	200	500	40	27,0	70	18	0,5	3	LC..1603..
	4	C4-CFOR -27070-03L080055-JET	55	80	40	27,0	70	18	0,5	3	LC..1603..
		-27070-03L100070-JET	70	100	40	27,0	70	18	0,5	3	LC..1603..
		-27070-03L130090-JET	90	130	40	27,0	70	18	0,5	3	LC..1603..
		-27070-03L170110-JET	110	170	40	27,0	70	18	0,5	3	LC..1603..
		-27070-03L230140-JET	140	230	40	27,0	70	18	0,5	3	LC..1603..
		-27070-03L500200-JET	200	500	40	27,0	70	18	0,5	3	LC..1603..
C4	4	C4-CFOR -27080-04R080055-JET	55	80	40	27,0	80	24	0,5	4	LC..1604..
		-27080-04R100070-JET	70	100	40	27,0	80	24	0,5	4	LC..1604..
		-27080-04R130090-JET	90	130	40	27,0	80	24	0,5	4	LC..1604..
		-27080-04R170110-JET	110	170	40	27,0	80	24	0,5	4	LC..1604..
		-27080-04R230140-JET	140	230	40	27,0	80	24	0,5	4	LC..1604..
		-27080-04R500200-JET	200	500	40	27,0	80	24	0,5	4	LC..1604..
	4	C4-CFOR -27080-04L080055-JET	55	80	40	27,0	80	24	0,5	4	LC..1604..
		-27080-04L100070-JET	70	100	40	27,0	80	24	0,5	4	LC..1604..
		-27080-04L130090-JET	90	130	40	27,0	80	24	0,5	4	LC..1604..
		-27080-04L170110-JET	110	170	40	27,0	80	24	0,5	4	LC..1604..
		-27080-04L230140-JET	140	230	40	27,0	80	24	0,5	4	LC..1604..
		-27080-04L500200-JET	200	500	40	27,0	80	24	0,5	4	LC..1604..

Initial plunge (INPLM/INPLX) relates to face groove diameter, see page(s) 477.

**Max depth of cut for LCGF/LCMF16.. = 14 mm

Spare Parts, Parts included in delivery

For holder	Clamp key	Clamp screw	Torque value Nm
CFOR/L...03	4SMS795	TCEI0513	6,0
CFOR/L...04	5SMS795	TCEI0613	8,0

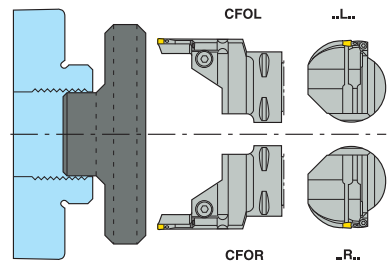

Please check availability in current price and stock-list

Toolholders for inserts LCGF, LCGN, LCMF and LCMR



• For insert programme, see page(s) 578-583, 593-594

CFOR...R...JET, CFOL...L...JET

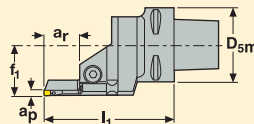

Right-hand version with right-hand blade shown

$$a_r = 6 \times a_p$$

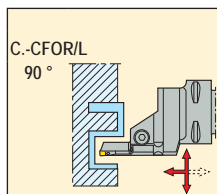

Capto size	Part No.	Dimensions in mm							KG	Seat size	Insert	
		INPLM	INPLX	D _{5m}	f ₁	l ₁	a _r **					
C4	5	C4-CFOR -27085-05R080055-JET	55	80	40	27,0	85	30	0,5	5	LC..1605..	
		-27085-05R100070-JET	70	100	40	27,0	85	30	0,5	5	LC..1605..	
		-27085-05R130090-JET	90	130	40	27,0	85	30	0,5	5	LC..1605..	
		-27085-05R170110-JET	110	170	40	27,0	85	30	0,5	5	LC..1605..	
		-27085-05R230140-JET	140	230	40	27,0	85	30	0,5	5	LC..1605..	
		-27085-05R500200-JET	200	500	40	27,0	85	30	0,5	5	LC..1605..	
		C4-CFOL -27085-05L080055-JET	55	80	40	27,0	85	30	0,5	5	LC..1605..	
		-27085-05L100070-JET	70	100	40	27,0	85	30	0,5	5	LC..1605..	
		-27085-05L130090-JET	90	130	40	27,0	85	30	0,5	5	LC..1605..	
		-27085-05L170110-JET	110	170	40	27,0	85	30	0,5	5	LC..1605..	
		-27085-05L230140-JET	140	230	40	27,0	85	30	0,5	5	LC..1605..	
		-27085-05L500200-JET	200	500	40	27,0	85	30	0,5	5	LC..1605..	

Initial plunge (INPLM/INPLX) relates to face groove diameter, see page(s) 477.

**Max depth of cut for LCGF/LCMF16.. = 14 mm

Spare Parts, Parts included in delivery

For holder	Clamp key	Clamp screw	Torque value Nm
CFOR/L..05	5SMS795	TCEI0613	8,0

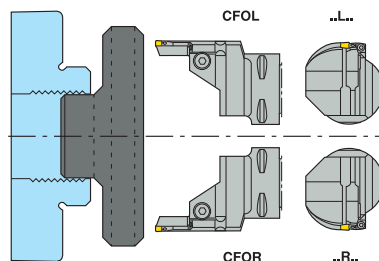

Please check availability in current price and stock-list

Toolholders for inserts LCGF, LCGN, LCMF and LCMR



• For insert programme, see page(s) 578-583, 593-594

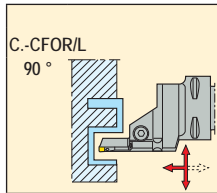
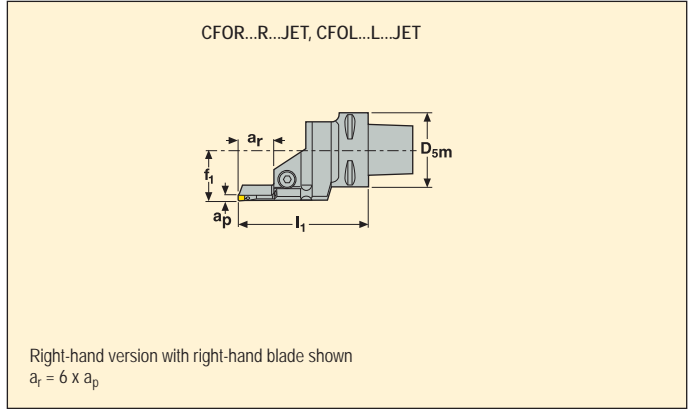

Capto size	Part No.	Dimensions in mm						KG	Seat size	Insert		
		INPLM	INPLX	D _{5m}	f ₁	l ₁	a _r **					
C5	3	C5-CFOR -35070-03R080055-JET	55	80	50	35,0	70	18	0,7	3	LC..1603..	
		-35070-03R100070-JET	70	100	50	35,0	70	18	0,7	3	LC..1603..	
		-35070-03R130090-JET	90	130	50	35,0	70	18	0,7	3	LC..1603..	
		-35070-03R170110-JET	110	170	50	35,0	70	18	0,7	3	LC..1603..	
		-35070-03R230140-JET	140	230	50	35,0	70	18	0,7	3	LC..1603..	
		-35070-03R500200-JET	200	500	50	35,0	70	18	0,7	3	LC..1603..	
		C5-CFOL -35070-03L080055-JET	55	80	50	35,0	70	18	0,7	3	LC..1603..	
	-35070-03L100070-JET	70	100	50	35,0	70	18	0,7	3	LC..1603..		
	-35070-03L130090-JET	90	130	50	35,0	70	18	0,7	3	LC..1603..		
	-35070-03L170110-JET	110	170	50	35,0	70	18	0,7	3	LC..1603..		
	-35070-03L230140-JET	140	230	50	35,0	70	18	0,7	3	LC..1603..		
	-35070-03L500200-JET	200	500	50	35,0	70	18	0,7	3	LC..1603..		
	4	C5-CFOR	-35080-04R080055-JET	55	80	50	35,0	80	24	0,7	4	LC..1604..
			-35080-04R100070-JET	70	100	50	35,0	80	24	0,7	4	LC..1604..
-35080-04R130090-JET			90	130	50	35,0	80	24	0,7	4	LC..1604..	
-35080-04R170110-JET			110	170	50	35,0	80	24	0,7	4	LC..1604..	
-35080-04R230140-JET			140	230	50	35,0	80	24	0,7	4	LC..1604..	
-35080-04R500200-JET			200	500	50	35,0	80	24	0,7	4	LC..1604..	
C5-CFOL -35080-04L080055-JET			55	80	50	35,0	80	24	0,7	4	LC..1604..	
-35080-04L100070-JET		70	100	50	35,0	80	24	0,7	4	LC..1604..		
-35080-04L130090-JET		90	130	50	35,0	80	24	0,7	4	LC..1604..		
-35080-04L170110-JET		110	170	50	35,0	80	24	0,7	4	LC..1604..		
-35080-04L230140-JET		140	230	50	35,0	80	24	0,7	4	LC..1604..		
-35080-04L500200-JET		200	500	50	35,0	80	24	0,7	4	LC..1604..		

Initial plunge (INPLM/INPLX) relates to face groove diameter, see page(s) 477.

**Max depth of cut for LCGF/LCMF16.. = 14 mm

Spare Parts, Parts included in delivery

For holder	Clamp key	Clamp screw	Torque value Nm
CFOR/L...03	4SMS795	TCEI0513	6,0
CFOR/L...04	5SMS795	TCEI0613	8,0

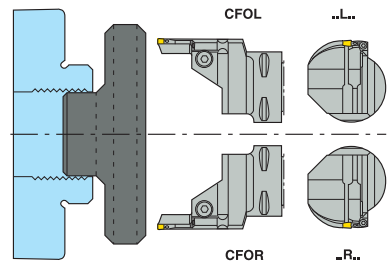

Please check availability in current price and stock-list

Toolholders for inserts LCGF, LCGN, LCMF and LCMR



• For insert programme, see page(s) 578-583, 593-594

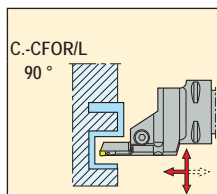
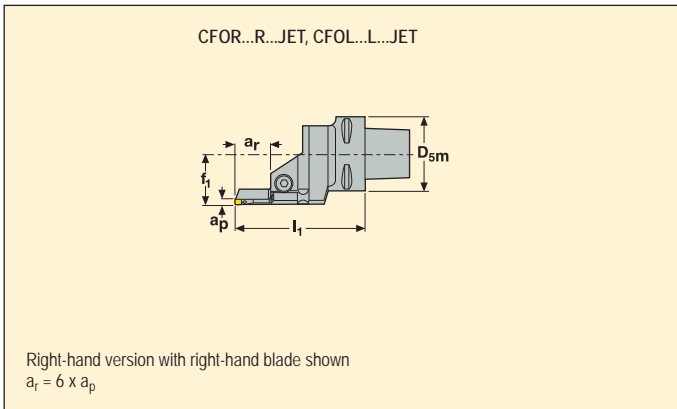

Capto size	Part No.	Dimensions in mm						KG	Seat size	Insert	
		INPLM	INPLX	D _{5m}	f ₁	l ₁	a _r **				
C5	5	C5-CFOR -35085-05R080055-JET	55	80	50	35,0	85	30	0,7	5	LC..1605..
		C5-CFOR -35085-05R100070-JET	70	100	50	35,0	85	30	0,7	5	LC..1605..
		C5-CFOR -35085-05R130090-JET	90	130	50	35,0	85	30	0,7	5	LC..1605..
		C5-CFOR -35085-05R170110-JET	110	170	50	35,0	85	30	0,7	5	LC..1605..
		C5-CFOR -35085-05R230140-JET	140	230	50	35,0	85	30	0,7	5	LC..1605..
		C5-CFOR -35085-05R500200-JET	200	500	50	35,0	85	30	0,7	5	LC..1605..
		C5-CFOL -35085-05L080055-JET	55	80	50	35,0	85	30	0,7	5	LC..1605..
		C5-CFOL -35085-05L100070-JET	70	100	50	35,0	85	30	0,7	5	LC..1605..
		C5-CFOL -35085-05L130090-JET	90	130	50	35,0	85	30	0,7	5	LC..1605..
		C5-CFOL -35085-05L170110-JET	110	170	50	35,0	85	30	0,7	5	LC..1605..
	C5-CFOL -35085-05L230140-JET	140	230	50	35,0	85	30	0,7	5	LC..1605..	
	C5-CFOL -35085-05L500200-JET	200	500	50	35,0	85	30	0,7	5	LC..1605..	
	6	C5-CFOR -35100-06R080055-JET	55	80	50	35,0	100	36	0,9	6	LC..1606..
		C5-CFOR -35100-06R100070-JET	70	100	50	35,0	100	36	0,9	6	LC..1606..
C5-CFOR -35100-06R130090-JET		90	130	50	35,0	100	36	0,9	6	LC..1606..	
C5-CFOR -35100-06R170110-JET		110	170	50	35,0	100	36	0,9	6	LC..1606..	
C5-CFOR -35100-06R230140-JET		140	230	50	35,0	100	36	0,9	6	LC..1606..	
C5-CFOR -35100-06R500200-JET		200	500	50	35,0	100	36	0,9	6	LC..1606..	
C5-CFOL -35100-06L080055-JET		50	80	50	35,0	100	36	0,9	6	LC..1606..	
C5-CFOL -35100-06L100070-JET		70	100	50	35,0	100	36	0,9	6	LC..1606..	
C5-CFOL -35100-06L130090-JET		90	130	50	35,0	100	36	0,9	6	LC..1606..	
C5-CFOL -35100-06L170110-JET		110	170	50	35,0	100	36	0,9	6	LC..1606..	
C5-CFOL -35100-06L230140-JET	140	230	50	35,0	100	36	0,9	6	LC..1606..		
C5-CFOL -35100-06L500200-JET	200	500	50	35,0	100	36	0,9	6	LC..1606..		

Initial plunge (INPLM/INPLX) relates to face groove diameter, see page(s) 477.

**Max depth of cut for LCGF/LCMF16.. = 14 mm

Spare Parts, Parts included in delivery

For holder	Clamp key	Clamp screw	Torque value Nm
CFOR/L...-05	5SMS795	TCEI0613	8,0
CFOR/L...-06	6SMS795	TCEI0815	10,0

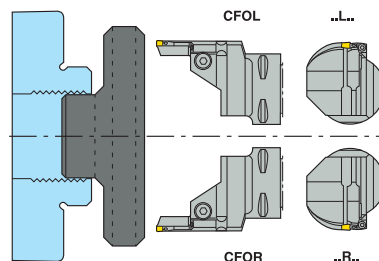

Please check availability in current price and stock-list

Toolholders for inserts LCGF, LCGN, LCMF and LCMR



• For insert programme, see page(s) 578-583, 593-594

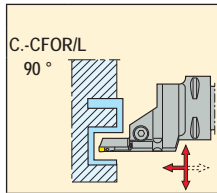
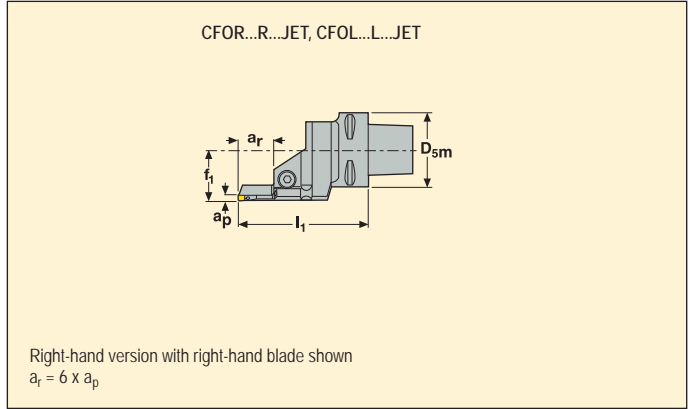

Capto size	Part No.	Dimensions in mm							KG	Seat size	Insert	
		INPLM	INPLX	D _{5m}	f ₁	l ₁	a _r **					
C6	3	C6-CFOR -45075-03R080055-JET	55	80	63	45,0	75	18	1,1	3	LC..1603..	
		-45075-03R100070-JET	70	100	63	45,0	75	18	1,1	3	LC..1603..	
		-45075-03R130090-JET	90	130	63	45,0	75	18	1,1	3	LC..1603..	
		-45075-03R170110-JET	110	170	63	45,0	75	18	1,1	3	LC..1603..	
		-45075-03R230140-JET	140	230	63	45,0	75	18	1,1	3	LC..1603..	
		-45075-03R500200-JET	200	500	63	45,0	75	18	1,1	3	LC..1603..	
	3	C6-CFOL -45075-03L080055-JET	55	80	63	45,0	75	18	1,1	3	LC..1603..	
		-45075-03L100070-JET	70	100	63	45,0	75	18	1,1	3	LC..1603..	
		-45075-03L130090-JET	90	130	63	45,0	75	18	1,1	3	LC..1603..	
		-45075-03L170110-JET	110	170	63	45,0	75	18	1,1	3	LC..1603..	
		-45075-03L230140-JET	140	230	63	45,0	75	18	1,1	3	LC..1603..	
		-45075-03L500200-JET	200	500	63	45,0	75	18	1,1	3	LC..1603..	
	4	C6-CFOR	-45080-04R080055-JET	55	80	63	45,0	80	24	1,1	4	LC..1604..
			-45080-04R100070-JET	70	100	63	45,0	80	24	1,1	4	LC..1604..
-45080-04R130090-JET			90	130	63	45,0	80	24	1,1	4	LC..1604..	
-45080-04R170110-JET			110	170	63	45,0	80	24	1,1	4	LC..1604..	
-45080-04R230140-JET			140	230	63	45,0	80	24	1,1	4	LC..1604..	
-45080-04R500200-JET			200	500	63	45,0	80	24	1,1	4	LC..1604..	
C6-CFOL		-45080-04L080055-JET	55	80	63	45,0	80	24	1,1	4	LC..1604..	
		-45080-04L100070-JET	70	100	63	45,0	80	24	1,1	4	LC..1604..	
		-45080-04L130090-JET	90	130	63	45,0	80	24	1,1	4	LC..1604..	
		-45080-04L170110-JET	110	170	63	45,0	80	24	1,1	4	LC..1604..	
		-45080-04L230140-JET	140	230	63	45,0	80	24	1,1	4	LC..1604..	
		-45080-04L500200-JET	200	500	63	45,0	80	24	1,1	4	LC..1604..	

Initial plunge (INPLM/INPLX) relates to face groove diameter, see page(s) 477.

**Max depth of cut for LCGF/LCMF16.. = 14 mm

Spare Parts, Parts included in delivery

For holder	Clamp key	Clamp screw	Torque value Nm
CFOR/L...03	4SMS795	TCEI0513	6,0
CFOR/L...04	5SMS795	TCEI0613	8,0

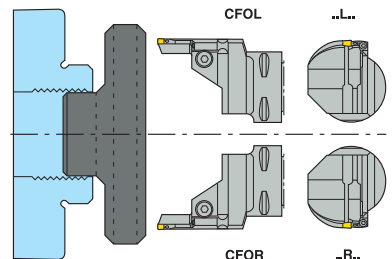

Please check availability in current price and stock-list

Toolholders for inserts LCGF, LCGN, LCMF and LCMR



• For insert programme, see page(s) 578-583, 593-594

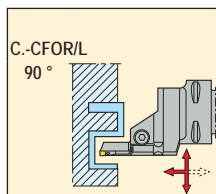
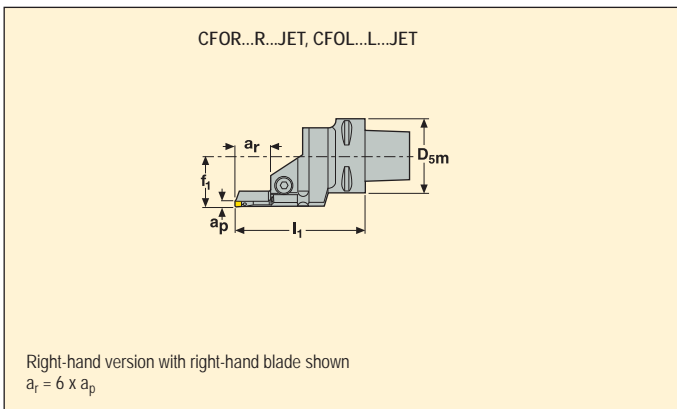

Capto size	Part No.	Dimensions in mm						KG	Seat size	Insert	
		INPLM	INPLX	D _{5m}	f ₁	l ₁	a _r **				
C6	5	C6-CFOR -45090-05R080055-JET	55	80	63	45,0	90	30	1,2	5	LC..1605..
		C6-CFOR -45090-05R100070-JET	70	100	63	45,0	90	30	1,2	5	LC..1605..
		C6-CFOR -45090-05R130090-JET	90	130	63	45,0	90	30	1,2	5	LC..1605..
		C6-CFOR -45090-05R170110-JET	110	170	63	45,0	90	30	1,2	5	LC..1605..
		C6-CFOR -45090-05R230140-JET	140	230	63	45,0	90	30	1,2	5	LC..1605..
	C6-CFOR -45090-05R500200-JET	200	500	63	45,0	90	30	1,2	5	LC..1605..	
	C6-CFOL -45090-05L080055-JET	55	80	63	45,0	90	30	1,2	5	LC..1605..	
	C6-CFOL -45090-05L100070-JET	70	100	63	45,0	90	30	1,2	5	LC..1605..	
	C6-CFOL -45090-05L130090-JET	90	130	63	45,0	90	30	1,2	5	LC..1605..	
	C6-CFOL -45090-05L170110-JET	110	170	63	45,0	90	30	1,2	5	LC..1605..	
C6-CFOL -45090-05L230140-JET	140	230	63	45,0	90	30	1,2	5	LC..1605..		
C6-CFOL -45090-05L500200-JET	200	500	63	45,0	90	30	1,2	5	LC..1605..		
6	C6-CFOR	C6-CFOR -45100-06R080055-JET	55	80	63	45,0	100	36	1,2	6	LC..1606..
		C6-CFOR -45100-06R100070-JET	70	100	63	45,0	100	36	1,2	6	LC..1606..
		C6-CFOR -45100-06R130090-JET	90	130	63	45,0	100	36	1,2	6	LC..1606..
		C6-CFOR -45100-06R170110-JET	110	170	63	45,0	100	36	1,3	6	LC..1606..
		C6-CFOR -45100-06R230140-JET	140	230	63	45,0	100	36	1,3	6	LC..1606..
	C6-CFOR -45100-06R500200-JET	200	500	63	45,0	100	36	1,3	6	LC..1606..	
	C6-CFOL	C6-CFOL -45100-06L080055-JET	55	80	63	45,0	100	36	1,2	6	LC..1606..
	C6-CFOL -45100-06L100070-JET	70	100	63	45,0	100	36	1,2	6	LC..1606..	
	C6-CFOL -45100-06L130090-JET	90	130	63	45,0	100	36	1,2	6	LC..1606..	
	C6-CFOL -45100-06L170110-JET	110	170	63	45,0	100	36	1,3	6	LC..1606..	
C6-CFOL -45100-06L230140-JET	140	230	63	45,0	100	36	1,3	6	LC..1606..		
C6-CFOL -45100-06L500200-JET	200	500	63	45,0	100	36	1,3	6	LC..1606..		

Initial plunge (INPLM/INPLX) relates to face groove diameter, see page(s) 477.

**Max depth of cut for LCGF/LCMF16.. = 14 mm

Spare Parts, Parts included in delivery

For holder	Clamp key	Clamp screw	Torque value Nm
CFOR/L...-05	5SMS795	TCEI0613	6,0
CFOR/L...-06	6SMS795	TCEI0815	10,0

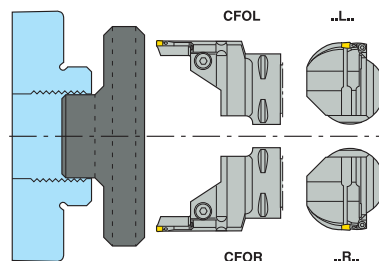

Please check availability in current price and stock-list

Toolholders for inserts LCGF, LCGN, LCMF and LCMR

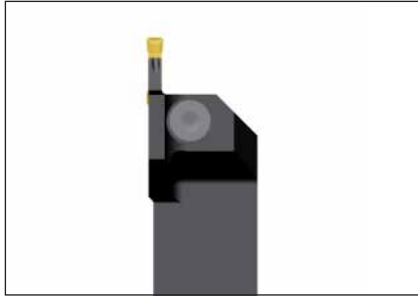

• For insert programme, see page(s) 578-591, 593-594

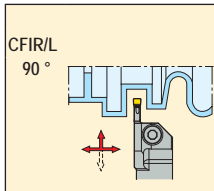
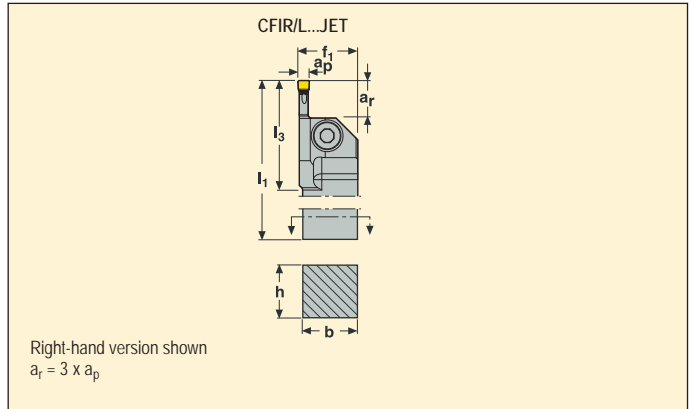

	Part No.	Dimensions in mm						KG	Seat size	
		h	b	l ₁	f ₁	l ₃	a _r **			
3	CFIR 2020K03JET	20	20	125	21,5	33,0	9	0,4	3	LC..1603..
	2525M03JET	25	25	150	26,5	33,0	9	0,7	3	LC..1603..
	3225P03JET	32	25	170	26,5	33,0	9	1,0	3	LC..1603..
	CFIL 2020K03JET	20	20	125	21,5	33,0	9	0,4	3	LC..1603..
	2525M03JET	25	25	150	26,5	33,0	9	0,7	3	LC..1603..
	3225P03JET	32	25	170	26,5	33,0	9	1,0	3	LC..1603..
4	CFIR 2020K04JET	20	20	125	21,5	39,0	12	0,4	4	LC..1604..
	2525M04JET	25	25	150	26,5	39,0	12	0,7	4	LC..1604..
	3225P04JET	32	25	170	26,5	39,0	12	1,0	4	LC..1604..
	CFIL 2020K04JET	20	20	125	21,5	39,0	12	0,4	4	LC..1604..
	2525M04JET	25	25	150	26,5	39,0	12	0,7	4	LC..1604..
	3225P04JET	32	25	170	26,5	39,0	12	1,0	4	LC..1604..
5	CFIR 2020K05JET	20	20	125	21,5	40,0	15	0,4	5	LC..1605..
	2525M05JET	25	25	150	26,5	40,0	15	0,7	5	LC..1605..
	3225P05JET	32	25	170	26,5	40,0	15	1,0	5	LC..1605..
	CFIL 2020K05JET	20	20	125	21,5	40,0	15	0,4	5	LC..1605..
	2525M05JET	25	25	150	26,5	40,0	15	0,7	5	LC..1605..
	3225P05JET	32	25	170	26,5	40,0	15	1,0	5	LC..1605..

**Max depth of cut for LCGF/LCMF16.. = 14 mm

Spare Parts, Parts included in delivery

For holder	Clamp key	Clamp screw	Plug	Torque value Nm
CFIR/L...03	4SMS795	TCEI0513	JET-P1/8-5MM	6,0
CFIR/L...04	5SMS795	TCEI0613	JET-P1/8-5MM	8,0
CFIR/L...05	5SMS795	TCEI0613	JET-P1/8-5MM	8,0

Please check availability in current price and stock-list

For more information on Jetstream Tooling® and accessories, please see page(s) 27-29 and 684.

Toolholders for inserts LCGF, LCGN, LCMF and LCMR

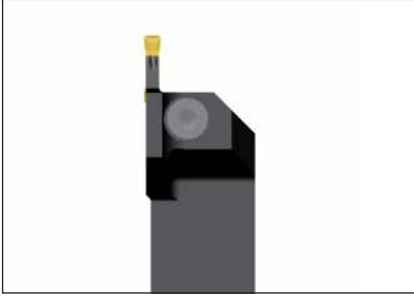

• For insert programme, see page(s) 578-589, 593-594

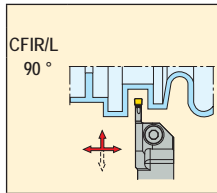
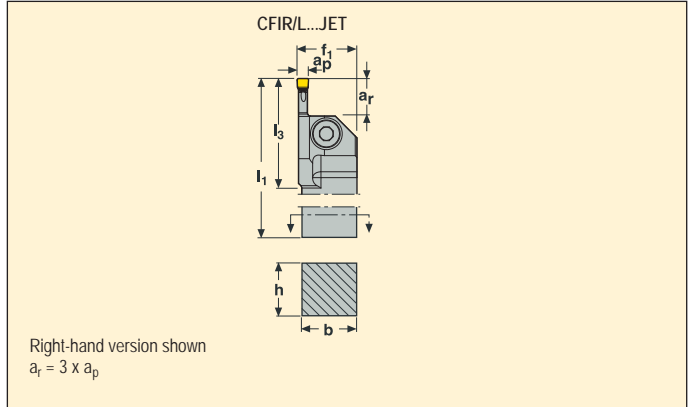

	Part No.	Dimensions in mm						KG	Seat size	
		h	b	l ₁	f ₁	l ₃	a _r **			
6	CFIR 2020K06JET	20	20	125	21,5	47,0	18	0,4	6	LC..1606..
	2525M06JET	25	25	150	26,5	47,0	18	0,7	6	LC..1606..
	3225P06JET	32	25	170	26,5	47,0	18	1,0	6	LC..1606..
	CFIL 2020K06JET	20	20	125	21,5	47,0	18	0,4	6	LC..1606..
	2525M06JET	25	25	150	26,5	47,0	18	0,7	6	LC..1606..
	3225P06JET	32	25	170	26,5	47,0	18	1,0	6	LC..1606..
8	CFIR 2525M08JET	25	25	150	28,0	57,0	24	0,7	8	LC..3008..
	3225P08JET	32	25	170	28,0	57,0	24	1,0	8	LC..3008..
	CFIL 2525M08JET	25	25	150	28,0	57,0	24	0,7	8	LC..3008..
	3225P08JET	32	25	170	28,0	57,0	24	1,0	8	LC..3008..

**Max depth of cut for LCGF/LCMF16.. = 14 mm

Spare Parts, Parts included in delivery

For holder	Clamp key	Clamp screw	Plug	Torque value Nm
CFIR/L20...06	5SMS795	TCEI0613	JET-P1/8-5MM	6,0
CFIR/L...06	6SMS795	TCEI0815	JET-P1/8-5MM	8,0
CFIR/L...08	6SMS795	TCEI1020	JET-P1/8-5MM	8,0

Please check availability in current price and stock-list
 For more information on Jetstream Tooling® and accessories, please see page(s) 27-29 and 684.

Toolholders for inserts LCGF, LCGN, LCMF and LCMR

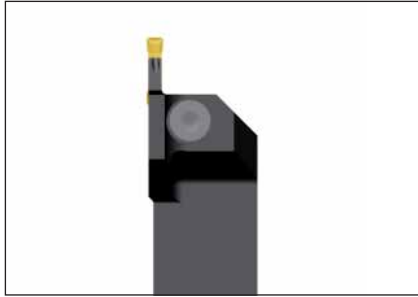

- For insert programme, see page(s) 578-591, 593-594

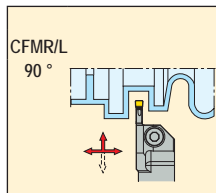
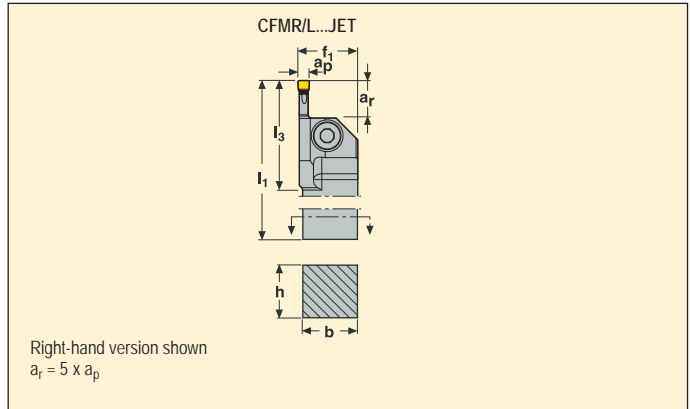

	Part No.	Dimensions in mm						KG	Seat size	
		h	b	l ₁	f ₁	l ₃	a _r **			
3	CFMR 2020K03JET	20	20	125	21,5	41,0	15	0,4	3	LC..1603..
	2525M03JET	25	25	150	26,5	41,0	15	0,7	3	LC..1603..
	3225P03JET	32	25	170	26,5	41,0	15	1,0	3	LC..1603..
	CFML 2525M03JET	25	25	150	26,5	41,0	15	0,7	3	LC..1603..
	3225P03JET	32	25	170	26,5	41,0	15	1,0	3	LC..1603..
	2020K03JET	20	20	125	21,5	41,0	15	0,4	3	LC..1603..
4	CFMR 2020K04JET	20	20	125	21,5	45,0	20	0,4	4	LC..1604..
	2525M04JET	25	25	150	26,5	45,0	20	0,7	4	LC..1604..
	3225P04JET	32	25	170	26,5	45,0	20	1,0	4	LC..1604..
	CFML 2020K04JET	20	20	125	21,5	45,0	20	0,4	4	LC..1604..
	2525M04JET	25	25	150	26,5	45,0	20	0,7	4	LC..1604..
	3225P04JET	32	25	170	26,5	45,0	20	1,0	4	LC..1604..
5	CFMR 2525M05JET	25	25	150	26,5	56,0	25	0,7	5	LC..1605..
	3225P05JET	32	25	170	26,5	56,0	25	0,9	5	LC..1605..
	CFML 2525M05JET	25	25	150	26,5	56,0	25	0,7	5	LC..1605..
	3225P05JET	32	25	170	26,5	56,0	25	0,9	5	LC..1605..
6	CFMR 2525M06JET	25	25	150	26,5	67,0	30	0,7	6	LC..1606..
	3225P06JET	32	25	170	26,5	67,0	30	0,9	6	LC..1606..
	CFML 2525M06JET	25	25	150	26,5	67,0	30	0,7	6	LC..1606..
	3225P06JET	32	25	170	26,5	67,0	30	0,9	6	LC..1606..

**Max depth of cut for LCGF/LCMF16.. = 14 mm

Spare Parts, Parts included in delivery

For holder	Clamp key	Clamp screw	Plug	Torque value Nm
CFMR/L...-03	4SMS795	TCEI0513	JET-P1/8-5MM	6,0
CFMR/L...-04	5SMS795	TCEI0613	JET-P1/8-5MM	8,0
CFMR/L...-05	5SMS795	TCEI0613	JET-P1/8-5MM	8,0
CFMR/L...-06	6SMS795	TCEI0815	JET-P1/8-5MM	10,0

Please check availability in current price and stock-list

For more information on Jetstream Tooling® and accessories, please see page(s) 27-29 and 684.

Toolholders for inserts LCMF



• For insert programme, see page(s) 577

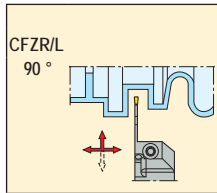
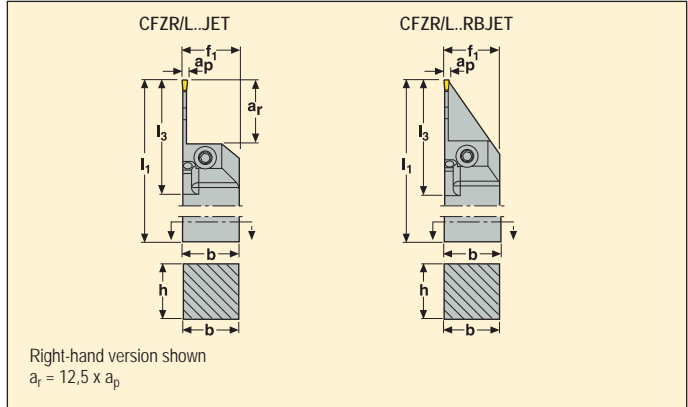

	Part No.	Dimensions in mm							KG	Seat size	
		h	b	l ₁	f ₁	l ₃	a _r	D _m *			
2	CFZR 2020M2802JET	20	20	150	20,0	50,0	26	–	0,4	2	LC..2802..
	2525M2802JET	25	25	150	25,0	50,0	26	–	0,6	2	LC..2802..
	CFZL 2020M2802JET	20	20	150	20,0	50,0	26	–	0,4	2	LC..2802..
	2525M2802JET	25	25	150	25,0	50,0	26	–	0,6	2	LC..2802..
2	CFZR 2020M2802RBJET	20	20	150	20,0	51,7	–	52	0,5	2	LC..2802..
	2525M2802RBJET	25	25	150	25,0	51,7	–	52	0,7	2	LC..2802..
	CFZL 2020M2802RBJET	20	20	150	20,0	51,7	–	52	0,5	2	LC..2802..
	2525M2802RBJET	25	25	150	25,0	51,7	–	52	0,7	2	LC..2802..

*Due to the design, grooving depth is limited, see page(s) 477

Spare Parts, Parts included in delivery

For holder	Clamp key	Clamp screw	Plug	Torque value Nm
CFSR/L..28	4SMS795	TCEI0513	JET-P1/8-5MM	6,0

Please check availability in current price and stock-list
 For more information on Jetstream Tooling® and accessories, please see page(s) 27-29 and 684.

Toolholders for inserts LCGF, LCGN, LCMF and LCMR



• For insert programme, see page(s) 578-583, 593-594

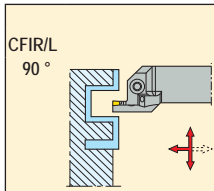
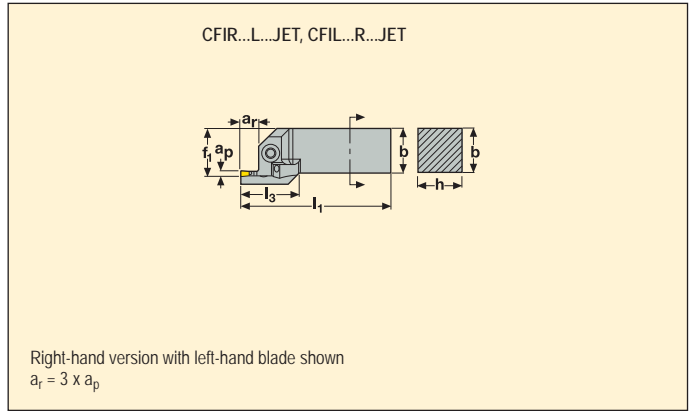

	Part No.	Dimensions in mm								KG	Seat size	
		INPLM	INPLX	h	b	l ₁	f ₁	l ₃	a _r **			
3	CFIR2525M03L080055-JET	55	80	25	25	150	26,5	33,0	9	0,7	3	LC..1603..
	CFIL2525M03R080055-JET	55	80	25	25	150	26,5	33,0	9	0,7	3	LC..1603..
4	CFIR2525M04L080055-JET	55	80	25	25	150	26,5	36,0	12	0,7	4	LC..1604..
	CFIL2525M04R080055-JET	55	80	25	25	150	26,5	36,0	12	0,7	4	LC..1604..
5	CFIR2525M05L080055-JET	55	80	25	25	150	26,5	40,0	15	0,7	5	LC..1605..
	CFIL2525M05R080055-JET	55	80	25	25	150	26,5	40,0	15	0,7	5	LC..1605..
6	CFIR2525M06L080055-JET	55	80	25	25	150	26,5	46,0	18	0,7	6	LC..1606..
	CFIL2525M06R080055-JET	55	80	25	25	150	26,5	46,0	18	0,7	6	LC..1606..

Initial plunge (INPLM/INPLX) relates to face groove diameter, see page(s) 477.

**Max depth of cut for LCGF/LCMF16.. = 14 mm

Spare Parts, Parts included in delivery

For holder	Clamp key	Clamp screw	Plug	Torque value Nm
CFIR/L...-03	4SMS795	TCEI0513	JET-P1/8-5MM	6,0
CFIR/L...-04	5SMS795	TCEI0613	JET-P1/8-5MM	8,0
CFIR/L...-05	5SMS795	TCEI0613	JET-P1/8-5MM	8,0
CFIR/L...-06	6SMS795	TCEI0815	JET-P1/8-5MM	10,0

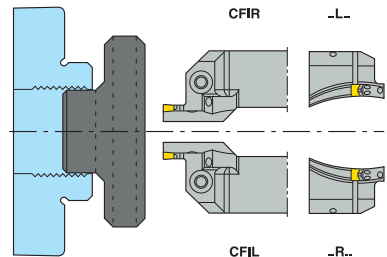

Please check availability in current price and stock-list

For more information on Jetstream Tooling® and accessories, please see page(s) 27-29 and 684.

Toolholders for inserts LCGF, LCGN, LCMF and LCMR



• For insert programme, see page(s) 578-583, 593-594

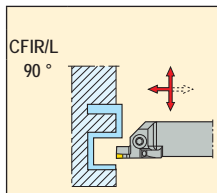
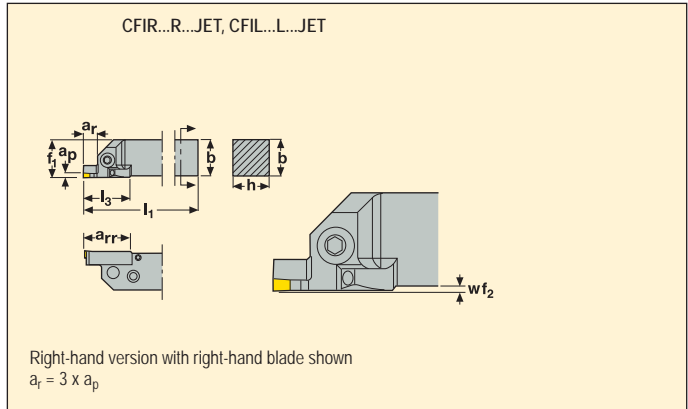

Part No.	Dimensions in mm											KG	Seat size	Image
	INPLM	INPLX	h	b	l ₁	f ₁	wf ₂	l ₃	a _r	a _{rr}				
3	CFIR 2525M03R080055-JET	55	80	25	25	150	26,5	1,5	33,0	9	33	0,7	3	LC..1603..
	2525M03R100070-JET	70	100	25	25	150	26,5	1,5	33,0	9	33	0,7	3	LC..1603..
	2525M03R130090-JET	90	130	25	25	150	26,5	1,5	33,0	9	33	0,7	3	LC..1603..
	2525M03R170110-JET	110	170	25	25	150	26,5	1,5	33,0	9	33	0,7	3	LC..1603..
	CFIL 2525M03L080055-JET	55	80	25	25	150	26,5	1,5	33,0	9	33	0,7	3	LC..1603..
	2525M03L100070-JET	70	100	25	25	150	26,5	1,5	33,0	9	33	0,7	3	LC..1603..
	2525M03L130090-JET	90	130	25	25	150	26,5	1,5	33,0	9	33	0,7	3	LC..1603..
	2525M03L170110-JET	110	170	25	25	150	26,5	1,5	33,0	9	33	0,7	3	LC..1603..
	4	CFIR 2525M04R080055-JET	55	80	25	25	150	26,5	1,5	36,0	12	36	0,7	4
2525M04R100070-JET		70	100	25	25	150	26,5	1,5	36,0	12	36	0,7	4	LC..1604..
2525M04R130090-JET		90	130	25	25	150	26,5	1,5	36,0	12	36	0,7	4	LC..1604..
2525M04R170110-JET		110	170	25	25	150	26,5	1,5	36,0	12	36	0,7	4	LC..1604..
2525M04R230140-JET		140	230	25	25	150	26,5	1,5	36,0	12	36	0,7	4	LC..1604..
CFIL 2525M04L080055-JET		55	80	25	25	150	26,5	1,5	36,0	12	36	0,7	4	LC..1604..
2525M04L100070-JET		70	100	25	25	150	26,5	1,5	36,0	12	36	0,7	4	LC..1604..
2525M04L130090-JET		90	130	25	25	150	26,5	1,5	36,0	12	36	0,7	4	LC..1604..
2525M04L170110-JET		110	170	25	25	150	26,5	1,5	36,0	12	36	0,7	4	LC..1604..
2525M04L230140-JET	140	230	25	25	150	26,5	1,5	36,0	12	36	0,7	4	LC..1604..	

Initial plunge (INPLM/INPLX) relates to face groove diameter, see page(s) 477.

Spare Parts, Parts included in delivery

For holder	Clamp key	Clamp screw	Plug	Torque value Nm
CFIR/L...-03	4SMS795	TCEI0513	JET-P1/8-5MM	6,0
CFIR/L...-04	5SMS795	TCEI0613	JET-P1/8-5MM	8,0

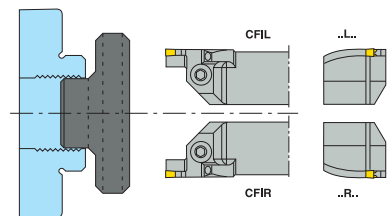

Please check availability in current price and stock-list

For more information on Jetstream Tooling® and accessories, please see page(s) 27-29 and 684.

Toolholders for inserts LCGF, LCGN, LCMF and LCMR



• For insert programme, see page(s) 578-583, 593-594

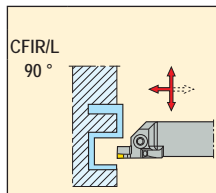
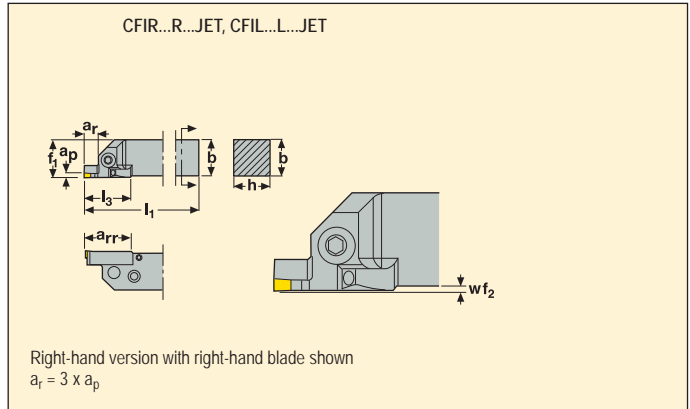

Part No.	Dimensions in mm											KG	Seat size	Image
	INPLM	INPLX	h	b	l ₁	f ₁	wf ₂	l ₃	a _r **	a _r				
5	CFIR 2525M05R080055-JET	55	80	25	25	150	26,5	1,5	40,0	15	40	0,7	5	LC..1605..
	2525M05R100070-JET	70	100	25	25	150	26,5	1,5	40,0	15	40	0,7	5	LC..1605..
	2525M05R130090-JET	90	130	25	25	150	26,5	1,5	40,0	15	40	0,7	5	LC..1605..
	2525M05R170110-JET	110	170	25	25	150	26,5	1,5	40,0	15	40	0,7	5	LC..1605..
	2525M05R230140-JET	140	230	25	25	150	26,5	1,5	40,0	15	40	0,7	5	LC..1605..
	CFIL 2525M05L080055-JET	55	80	25	25	150	26,5	1,5	40,0	15	40	0,7	5	LC..1605..
	2525M05L100070-JET	70	100	25	25	150	26,5	1,5	40,0	15	40	0,7	5	LC..1605..
	2525M05L130090-JET	90	130	25	25	150	26,5	1,5	40,0	15	40	0,7	5	LC..1605..
	2525M05L170110-JET	110	170	25	25	150	26,5	1,5	40,0	15	40	0,7	5	LC..1605..
	2525M05L230140-JET	140	230	25	25	150	26,5	1,5	40,0	15	40	0,7	5	LC..1605..
6	CFIR 2525M06R080055-JET	55	80	25	25	150	26,5	1,5	46,0	18	46	0,7	6	LC..1606..
	2525M06R100070-JET	70	100	25	25	150	26,5	1,5	46,0	18	46	0,7	6	LC..1606..
	2525M06R130090-JET	90	130	25	25	150	26,5	1,5	46,0	18	46	0,7	6	LC..1606..
	2525M06R170110-JET	110	170	25	25	150	26,5	1,5	46,0	18	46	0,7	6	LC..1606..
	2525M06R230140-JET	140	230	25	25	150	26,5	1,5	46,0	18	46	0,7	6	LC..1606..
	CFIL 2525M06L080055-JET	55	80	25	25	150	26,5	1,5	46,0	18	46	0,7	6	LC..1606..
	2525M06L100070-JET	70	100	25	25	150	26,5	1,5	46,0	18	46	0,7	6	LC..1606..
	2525M06L130090-JET	90	130	25	25	150	26,5	1,5	46,0	18	46	0,7	6	LC..1606..
	2525M06L170110-JET	110	170	25	25	150	26,5	1,5	46,0	18	46	0,7	6	LC..1606..
	2525M06L230140-JET	140	230	25	25	150	26,5	1,5	46,0	18	46	0,7	6	LC..1606..

Initial plunge (INPLM/INPLX) relates to face groove diameter, see page(s) 477.

**Max depth of cut for LCGF/LCMF16.. = 14 mm

Spare Parts, Parts included in delivery

For holder	Clamp key	Clamp screw	Plug	Torque value Nm
CFIR/L...-05	5SMS795	TCEI0613	JET-P1/8-5MM	8,0
CFIR/L...-06	6SMS795	TCEI0815	JET-P1/8-5MM	10,0

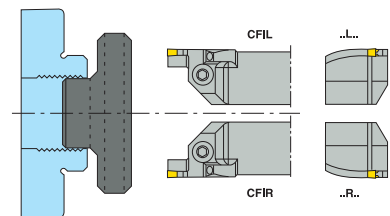

Please check availability in current price and stock-list

For more information on Jetstream Tooling® and accessories, please see page(s) 27-29 and 684.

Toolholders for inserts LCGF, LCGN, LCMF and LCMR



- For insert programme, see page(s) 578-583, 593-594

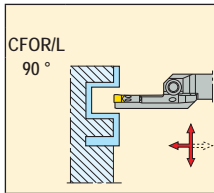
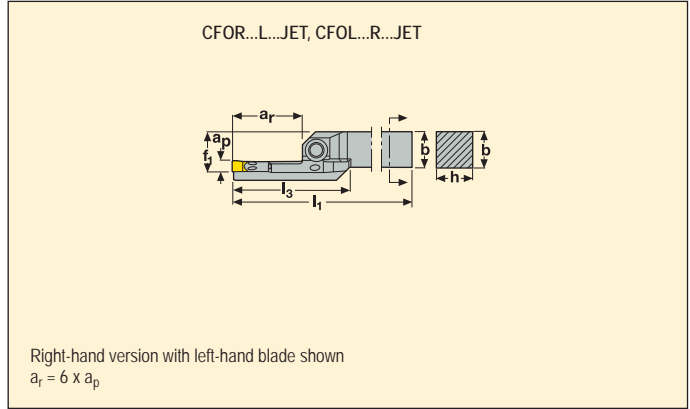

Part No.	Dimensions in mm									KG	Seat size	Image
	INPLM	INPLX	h	b	l ₁	f ₁	l ₃	a _r **				
3	CFOR 2525M03L080055-JET	55	80	25	25	150	26,5	43,0	18	0,7	3	LC..1603..
	2525M03L100070-JET	70	100	25	25	150	26,5	43,0	18	0,7	3	LC..1603..
	2525M03L130090-JET	90	130	25	25	150	26,5	43,0	18	0,7	3	LC..1603..
	2525M03L170110-JET	110	170	25	25	150	26,5	43,0	18	0,7	3	LC..1603..
	2525M03L230140-JET	140	230	25	25	150	26,5	43,0	18	0,7	3	LC..1603..
	2525M03L500200-JET	200	500	25	25	150	26,5	43,0	18	0,7	3	LC..1603..
	CFOL 2525M03R080055-JET	55	80	25	25	150	26,5	43,0	18	0,7	3	LC..1603..
	2525M03R100070-JET	70	100	25	25	150	26,5	43,0	18	0,7	3	LC..1603..
	2525M03R130090-JET	90	130	25	25	150	26,5	43,0	18	0,7	3	LC..1603..
	2525M03R170110-JET	110	170	25	25	150	26,5	43,0	18	0,7	3	LC..1603..
	2525M03R230140-JET	140	230	25	25	150	26,5	43,0	18	0,7	3	LC..1603..
	2525M03R500200-JET	200	500	25	25	150	26,5	43,0	18	0,7	3	LC..1603..
4	CFOR 2525M04L080055-JET	55	80	25	25	150	26,5	51,0	24	0,7	4	LC..1604..
	2525M04L100070-JET	70	100	25	25	150	26,5	51,0	24	0,7	4	LC..1604..
	2525M04L130090-JET	90	130	25	25	150	26,5	51,0	24	0,7	4	LC..1604..
	2525M04L170110-JET	110	170	25	25	150	26,5	51,0	24	0,7	4	LC..1604..
	2525M04L230140-JET	140	230	25	25	150	26,5	51,0	24	0,7	4	LC..1604..
	2525M04L500200-JET	200	500	25	25	150	26,5	51,0	24	0,7	4	LC..1604..
	CFOL 2525M04R080055-JET	55	80	25	25	150	26,5	51,0	24	0,7	4	LC..1604..
	2525M04R100070-JET	70	100	25	25	150	26,5	51,0	24	0,7	4	LC..1604..
	2525M04R130090-JET	90	130	25	25	150	26,5	51,0	24	0,7	4	LC..1604..
	2525M04R170110-JET	110	170	25	25	150	26,5	51,0	24	0,7	4	LC..1604..
	2525M04R230140-JET	140	230	25	25	150	26,5	51,0	24	0,7	4	LC..1604..
	2525M04R500200-JET	200	500	25	25	150	26,5	51,0	24	0,7	4	LC..1604..

Initial plunge (INPLM/INPLX) relates to face groove diameter, see page(s) 477.

**Max depth of cut for LCGF/LCMF16.. = 14 mm

Spare Parts, Parts included in delivery

For holder	Clamp key	Clamp screw	Plug	Torque value Nm
CFIR/L...03	4SMS795	TCEI0513	JET-P1/8-5MM	6,0
CFIR/L...04	5SMS795	TCEI0613	JET-P1/8-5MM	8,0

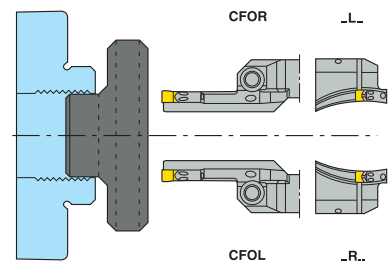

Please check availability in current price and stock-list

For more information on Jetstream Tooling® and accessories, please see page(s) 27-29 and 684.

Toolholders for inserts LCGF, LCGN, LCMF and LCMR



- For insert programme, see page(s) 578-583, 593-594

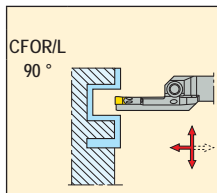
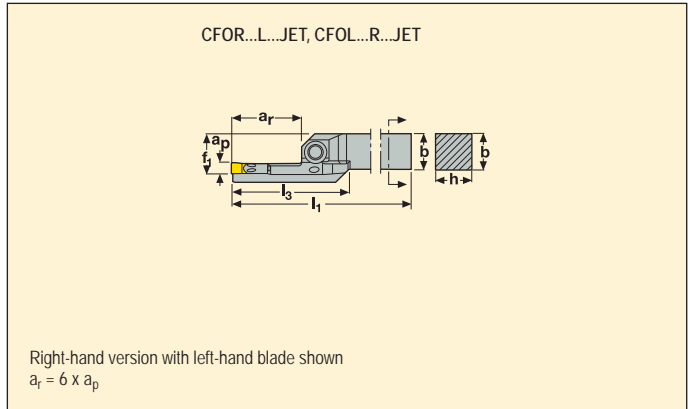

Part No.	Dimensions in mm									KG	Seat size	Insert
	INPLM	INPLX	h	b	l ₁	f ₁	l ₃	a _r **				
5	CFOR 2525M05L080055-JET	55	80	25	25	150	26,5	59,0	30	0,7	5	LC..1605..
	2525M05L100070-JET	70	100	25	25	150	26,5	59,0	30	0,7	5	LC..1605..
	2525M05L130090-JET	90	130	25	25	150	26,5	59,0	30	0,7	5	LC..1605..
	2525M05L170110-JET	110	170	25	25	150	26,5	59,0	30	0,7	5	LC..1605..
	2525M05L230140-JET	140	230	25	25	150	26,5	59,0	30	0,7	5	LC..1605..
	2525M05L500200-JET	200	500	25	25	150	26,5	59,0	30	0,7	5	LC..1605..
	CFOL 2525M05R080055-JET	55	80	25	25	150	26,5	59,0	30	0,7	5	LC..1605..
	2525M05R100070-JET	70	100	25	25	150	26,5	59,0	30	0,7	5	LC..1605..
	2525M05R130090-JET	90	130	25	25	150	26,5	59,0	30	0,7	5	LC..1605..
	2525M05R170110-JET	110	170	25	25	150	26,5	59,0	30	0,7	5	LC..1605..
	2525M05R230140-JET	140	230	25	25	150	26,5	59,0	30	0,7	5	LC..1605..
	2525M05R500200-JET	200	500	25	25	150	26,5	59,0	30	0,7	5	LC..1605..
6	CFOR 2525M06L080055-JET	55	80	25	25	150	26,5	70,0	36	0,7	6	LC..1606..
	2525M06L100070-JET	70	100	25	25	150	26,5	70,0	36	0,7	6	LC..1606..
	2525M06L130090-JET	90	130	25	25	150	26,5	70,0	36	0,7	6	LC..1606..
	2525M06L170110-JET	110	170	25	25	150	26,5	70,0	36	0,7	6	LC..1606..
	2525M06L230140-JET	140	230	25	25	150	26,5	70,0	36	0,7	6	LC..1606..
	2525M06L500200-JET	200	500	25	25	150	26,5	70,0	36	0,7	6	LC..1606..
	CFOL 2525M06R080055-JET	55	80	25	25	150	26,5	70,0	36	0,7	6	LC..1606..
	2525M06R100070-JET	70	100	25	25	150	26,5	70,0	36	0,7	6	LC..1606..
	2525M06R130090-JET	90	130	25	25	150	26,5	70,0	36	0,7	6	LC..1606..
	2525M06R170110-JET	110	170	25	25	150	26,5	70,0	36	0,7	6	LC..1606..
	2525M06R230140-JET	140	230	25	25	150	26,5	70,0	36	0,7	6	LC..1606..
	2525M06R500200-JET	200	500	25	25	150	26,5	70,0	36	0,7	6	LC..1606..

Initial plunge (INPLM/INPLX) relates to face groove diameter, see page(s) 477.

**Max depth of cut for LCGF/LCMF16.. = 14 mm

Spare Parts, Parts included in delivery

For holder	Clamp key	Clamp screw	Plug	Torque value Nm
CFIR/L...-05	5SMS795	TCEI0613	JET-P1/8-5MM	8,0
CFIR/L...-06	6SMS795	TCEI0815	JET-P1/8-5MM	10,0

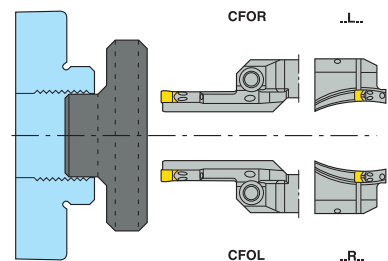

Please check availability in current price and stock-list

For more information on Jetstream Tooling® and accessories, please see page(s) 27-29 and 684.

Toolholders for inserts LCGF, LCGN, LCMF and LCMR



- For insert programme, see page(s) 578-583, 593-594

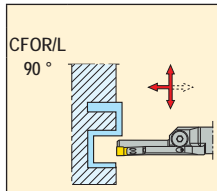
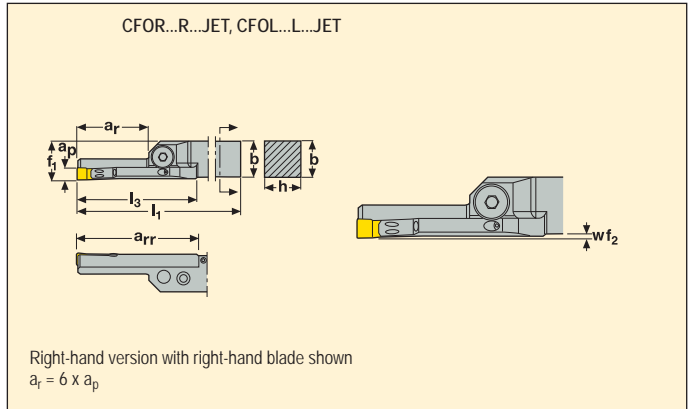

Part No.	Dimensions in mm											KG	Seat size	Insert
	INPLM	INPLX	h	b	l ₁	f ₁	wf ₂	l ₃	a _r **	a _{rr}				
3	CFOR 2525M03R080055-JET	55	80	25	25	150	26,5	1,5	43,0	18	43	0,7	3	LC..1603..
	2525M03R100070-JET	70	100	25	25	150	26,5	1,5	43,0	18	43	0,7	3	LC..1603..
	2525M03R130090-JET	90	130	25	25	150	26,5	1,5	43,0	18	43	0,7	3	LC..1603..
	2525M03R170110-JET	110	170	25	25	150	26,5	1,5	43,0	18	43	0,7	3	LC..1603..
	2525M03R230140-JET	140	230	25	25	150	26,5	1,5	43,0	18	43	0,7	3	LC..1603..
	2525M03R500200-JET	200	500	25	25	150	26,5	1,5	43,0	18	43	0,7	3	LC..1603..
	CFOL 2525M03L080055-JET	55	80	25	25	150	26,5	1,5	43,0	18	43	0,7	3	LC..1603..
	2525M03L100070-JET	70	100	25	25	150	26,5	1,5	43,0	18	43	0,7	3	LC..1603..
	2525M03L130090-JET	90	130	25	25	150	26,5	1,5	43,0	18	43	0,7	3	LC..1603..
	2525M03L170110-JET	110	170	25	25	150	26,5	1,5	43,0	18	43	0,7	3	LC..1603..
	2525M03L230140-JET	140	230	25	25	150	26,5	1,5	43,0	18	43	0,7	3	LC..1603..
	2525M03L500200-JET	200	500	25	25	150	26,5	1,5	43,0	18	43	0,7	3	LC..1603..
4	CFOR 2525M04R080055-JET	55	80	25	25	150	26,5	1,5	51,0	24	51	0,7	4	LC..1604..
	2525M04R100070-JET	70	100	25	25	150	26,5	1,5	51,0	24	51	0,7	4	LC..1604..
	2525M04R130090-JET	90	130	25	25	150	26,5	1,5	51,0	24	51	0,7	4	LC..1604..
	2525M04R170110-JET	110	170	25	25	150	26,5	1,5	51,0	24	51	0,7	4	LC..1604..
	2525M04R230140-JET	140	230	25	25	150	26,5	1,5	51,0	24	51	0,7	4	LC..1604..
	2525M04R500200-JET	200	500	25	25	150	26,5	1,5	51,0	24	51	0,7	4	LC..1604..
	CFOL 2525M04L080055-JET	55	80	25	25	150	26,5	1,5	51,0	24	51	0,7	4	LC..1604..
	2525M04L100070-JET	70	100	25	25	150	26,5	1,5	51,0	24	51	0,7	4	LC..1604..
	2525M04L130090-JET	90	130	25	25	150	26,5	1,5	51,0	24	51	0,7	4	LC..1604..
	2525M04L170110-JET	110	170	25	25	150	26,5	1,5	51,0	24	51	0,7	4	LC..1604..
	2525M04L230140-JET	140	230	25	25	150	26,5	1,5	51,0	24	51	0,7	4	LC..1604..
	2525M04L500200-JET	200	500	25	25	150	26,5	1,5	51,0	24	51	0,7	4	LC..1604..

Initial plunge (INPLM/INPLX) relates to face groove diameter, see page(s) 477.

*Max depth of cut for LCGF/LCMF16.. = 14 mm

Spare Parts, Parts included in delivery

For holder	Clamp key	Clamp screw	Plug	Torque value Nm
CFIR/L...-03	4SMS795	TCEI0513	JET-P1/8-5MM	6,0
CFIR/L...-04	5SMS795	TCEI0613	JET-P1/8-5MM	8,0

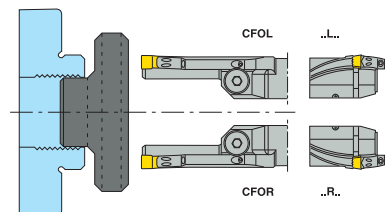

Please check availability in current price and stock-list

For more information on Jetstream Tooling® and accessories, please see page(s) 27-29 and 684.

Toolholders for inserts LCGF, LCGN, LCMF and LCMR



• For insert programme, see page(s) 578-583, 593-594

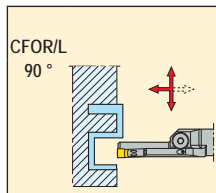
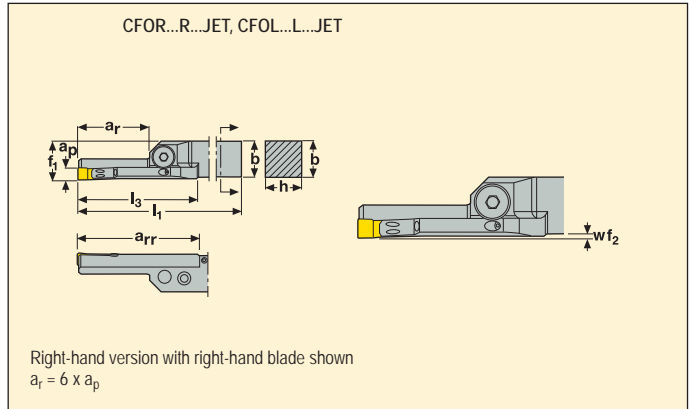

Part No.	Dimensions in mm										KG	Seat size	Image	
	INPLM	INPLX	h	b	l ₁	f ₁	wf ₂	l ₃	a _r **	a _r				
5	CFOR 2525M05R080055-JET	55	80	25	25	150	26,5	1,5	59,0	30	59	0,7	5	LC..1605..
	2525M05R100070-JET	70	100	25	25	150	26,5	1,5	59,0	30	59	0,7	5	LC..1605..
	2525M05R130090-JET	90	130	25	25	150	26,5	1,5	59,0	30	59	0,7	5	LC..1605..
	2525M05R170110-JET	110	170	25	25	150	26,5	1,5	59,0	30	59	0,7	5	LC..1605..
	2525M05R230140-JET	140	230	25	25	150	26,5	1,5	59,0	30	59	0,7	5	LC..1605..
	2525M05R500200-JET	200	500	25	25	150	26,5	1,5	59,0	30	59	0,7	5	LC..1605..
	CFOL 2525M05L080055-JET	55	80	25	25	150	26,5	1,5	59,0	30	59	0,7	5	LC..1605..
	2525M05L100070-JET	70	100	25	25	150	26,5	1,5	59,0	30	59	0,7	5	LC..1605..
	2525M05L130090-JET	90	130	25	25	150	26,5	1,5	59,0	30	59	0,7	5	LC..1605..
	2525M05L170110-JET	110	170	25	25	150	26,5	1,5	59,0	30	59	0,7	5	LC..1605..
	2525M05L230140-JET	140	230	25	25	150	26,5	1,5	59,0	30	59	0,7	5	LC..1605..
	2525M05L500200-JET	200	500	25	25	150	26,5	1,5	59,0	30	59	0,7	5	LC..1605..
6	CFOR 2525M06R080055-JET	55	80	25	25	150	26,5	1,5	70,0	36	70	0,7	6	LC..1606..
	2525M06R100070-JET	70	100	25	25	150	26,5	1,5	70,0	36	70	0,7	6	LC..1606..
	2525M06R130090-JET	90	130	25	25	150	26,5	1,5	70,0	36	70	0,7	6	LC..1606..
	2525M06R170110-JET	110	170	25	25	150	26,5	1,5	70,0	36	70	0,7	6	LC..1606..
	2525M06R230140-JET	140	230	25	25	150	26,5	1,5	70,0	36	70	0,7	6	LC..1606..
	2525M06R500200-JET	200	500	25	25	150	26,5	1,5	70,0	36	70	0,7	6	LC..1606..
	CFOL 2525M06L080055-JET	55	80	25	25	150	26,5	1,5	70,0	36	70	0,7	6	LC..1606..
	2525M06L100070-JET	70	100	25	25	150	26,5	1,5	70,0	36	70	0,7	6	LC..1606..
	2525M06L130090-JET	90	130	25	25	150	26,5	1,5	70,0	36	70	0,7	6	LC..1606..
	2525M06L170110-JET	110	170	25	25	150	26,5	1,5	70,0	36	70	0,7	6	LC..1606..
	2525M06L230140-JET	140	230	25	25	150	26,5	1,5	70,0	36	70	0,7	6	LC..1606..
	2525M06L500200-JET	200	500	25	25	150	26,5	1,5	70,0	36	70	0,7	6	LC..1606..

Initial plunge (INPLM/INPLX) relates to face groove diameter, see page(s) 477.

**Max depth of cut for LCGF/LCMF16.. = 14 mm

Spare Parts, Parts included in delivery

For holder	Clamp key	Clamp screw	Plug	Torque value Nm
CFIR/L...-05	5SMS795	TCEI0613	JET-P1/8-5MM	8,0
CFIR/L...-06	6SMS795	TCEI0815	JET-P1/8-5MM	10,0

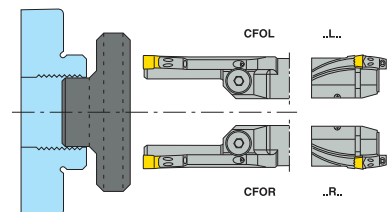

Please check availability in current price and stock-list

For more information on Jetstream Tooling® and accessories, please see page(s) 27-29 and 684.

Toolholders for inserts LCGF, LCGN, LCMF and LCMR



• For insert programme, see page(s) 578, 581-583

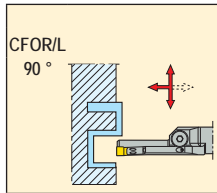
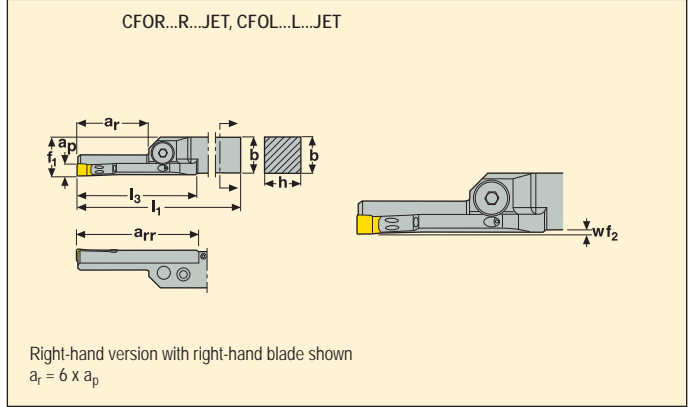

Part No.	Dimensions in mm											KG	Seat size	
	INPLM	INPLX	h	b	l ₁	f ₁	wf ₂	l ₃	a _r **	a _{rr}				
CFOR 3225P08R130090-JET	90	130	32	25	170	26,5	1,5	83,0	48	83	0,9	8	LC...3008..	
3225P08R170110-JET	110	170	32	25	170	26,5	1,5	83,0	48	83	0,9	8	LC...3008..	
3225P08R230140-JET	140	230	32	25	170	26,5	1,5	83,0	48	83	0,9	8	LC...3008..	
3225P08R500200-JET	200	500	32	25	170	26,5	1,5	83,0	48	83	0,9	8	LC...3008..	
CFOL 3225P08L130090-JET	90	130	32	25	170	26,5	1,5	83,0	48	83	0,9	8	LC...3008..	
3225P08L170110-JET	110	170	32	25	170	26,5	1,5	83,0	48	83	0,9	8	LC...3008..	
3225P08L230140-JET	140	230	32	25	170	26,5	1,5	83,0	48	83	0,9	8	LC...3008..	
3225P08L500200-JET	200	500	32	25	170	26,5	1,5	83,0	48	83	0,9	8	LC...3008..	

Initial plunge (INPLM/INPLX) relates to face groove diameter, see page(s) 477.

**Max depth of cut for LCGF/LCMF30.. = 28 mm

Spare Parts, Parts included in delivery

For holder	Clamp key	Clamp screw	Plug	Torque value Nm
CFIR/L...-08				15,0
	6SMS795	TCE11020	JET-P1/8-5MM	

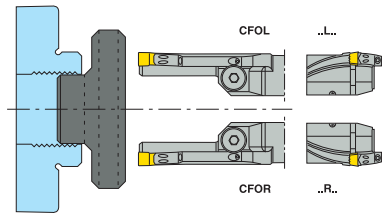

Please check availability in current price and stock-list
 For more information on Jetstream Tooling® and accessories, please see page(s) 27-29 and 684.

Toolholders for inserts LCGN, LCMF and LCMR



- For insert programme, see page(s) 578-583, 593-594

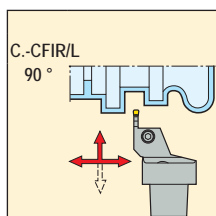
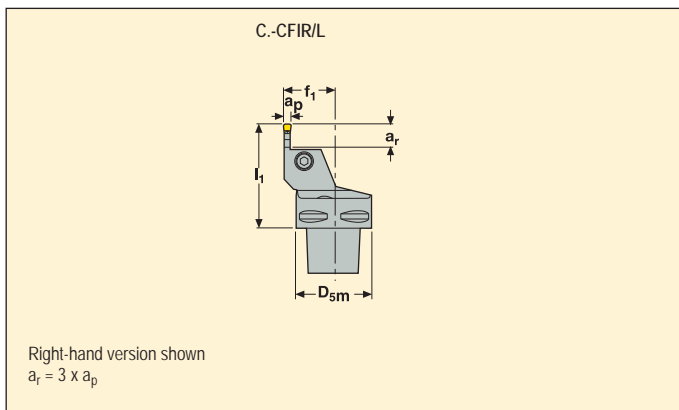

Capto size	Part No.	Dimensions in mm					DCINN3*	KG	Seat size	Insert
		D _{5m}	f ₁	l ₁	a _r **					
C4	C4-CFIR-27055-03	40	27,0	55	9	195	0,4	3	LC..1603..	
	C4-CFIL-27055-03	40	27,0	55	9	195	0,4	3	LC..1603..	
	C4-CFIR-27055-04	40	27,0	55	12	195	0,4	4	LC..1604..	
	C4-CFIL-27055-04	40	27,0	55	12	195	0,4	4	LC..1604..	
	C4-CFIR-27055-05	40	27,0	55	15	195	0,4	5	LC..1605..	
	C4-CFIL-27055-05	40	27,0	55	15	195	0,4	5	LC..1605..	
C5	C5-CFIR-35060-03	50	35,0	60	9	195	0,6	3	LC..1603..	
	C5-CFIL-35060-03	50	35,0	60	9	195	0,6	3	LC..1603..	
	C5-CFIR-35060-04	50	35,0	60	12	195	0,6	4	LC..1604..	
	C5-CFIL-35060-04	50	35,0	60	12	195	0,6	4	LC..1604..	
	C5-CFIR-35060-05	50	35,0	60	15	195	0,6	5	LC..1605..	
	C5-CFIL-35060-05	50	35,0	60	15	195	0,6	5	LC..1605..	
	C5-CFIR-35065-06	50	35,0	65	18	195	0,7	6	LC..1606..	
	C5-CFIL-35065-06	50	35,0	65	18	195	0,7	6	LC..1606..	

*DCINN3 – minimum bore diameter for internal application, see page(s) 477.

**Max depth of cut for LCMF16 = 14 mm

Spare Parts, Parts included in delivery

For holder	Clamp key	Clamp screw	Torque value Nm
CFIR/L...03	3SMS795	MC6S4X18	3,5
CFIR/L...04	4SMS795	MC6S5X18	5,0
CFIR/L...05	4SMS795	MC6S5X18	5,0
CFIR/L...06	6SMS795	TCEI0815	10,0

Please check availability in current price and stock-list

Toolholders for inserts LCGN, LCMF and LCMR



- For insert programme, see page(s) 578-583, 593-594

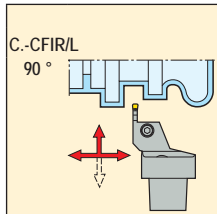
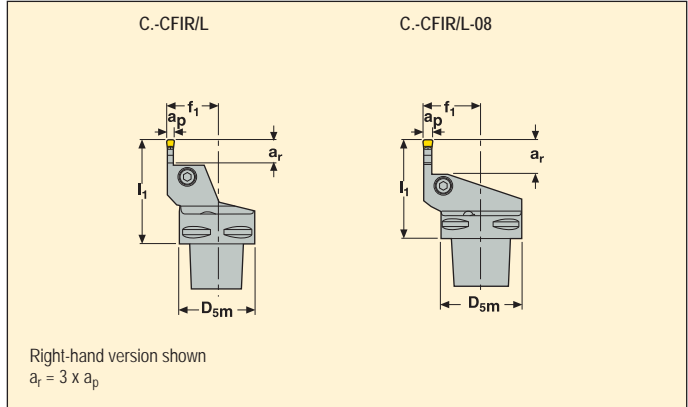

Capto size	Part No.	Dimensions in mm					DCINN3*	KG	Seat size	Insert
		D _{5m}	f ₁	l ₁	a _r **					
C6	C6-CFIR-45065-03	63	45,0	65	9	195	1,0	3	LC..1603..	
	C6-CFIL-45065-03	63	45,0	65	9	195	1,0	3	LC..1603..	
	C6-CFIR-45065-04	63	45,0	65	12	195	1,0	4	LC..1604..	
	C6-CFIL-45065-04	63	45,0	65	12	195	1,0	4	LC..1604..	
	C6-CFIR-45065-05	63	45,0	65	15	195	1,0	5	LC..1605..	
	C6-CFIL-45065-05	63	45,0	65	15	195	1,0	5	LC..1605..	
	C6-CFIR-45065-06	63	45,0	65	18	195	1,0	6	LC..1606..	
	C6-CFIL-45065-06	63	45,0	65	18	195	1,0	6	LC..1606..	
	C6-CFIR-45075-08	63	45,0	75	24	195	1,2	8	LC..3008..	
	C6-CFIL-45075-08	63	45,0	75	24	195	1,2	8	LC..3008..	

*DCINN3 – minimum bore diameter for internal application, see page(s) 477.

**Max depth of cut for LCMF16 = 14 mm

Spare Parts, Parts included in delivery

For holder	Clamp key	Clamp screw	Torque value Nm
CFIR/L...-03	3SMS795	MC6S4X18	3,5
CFIR/L...-04	4SMS795	MC6S5X18	5,0
CFIR/L...-05	4SMS795	MC6S5X18	5,0
CFIR/L...-06	6SMS795	TCEI0815	10,0
CFIR/L...-08	6SMS795	TCEI0825	10,0

Please check availability in current price and stock-list

Toolholders for inserts LCGF, LCGN, LCMF and LCMR



- For insert programme, see page(s) 578-591, 593-594

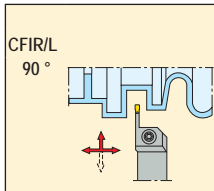
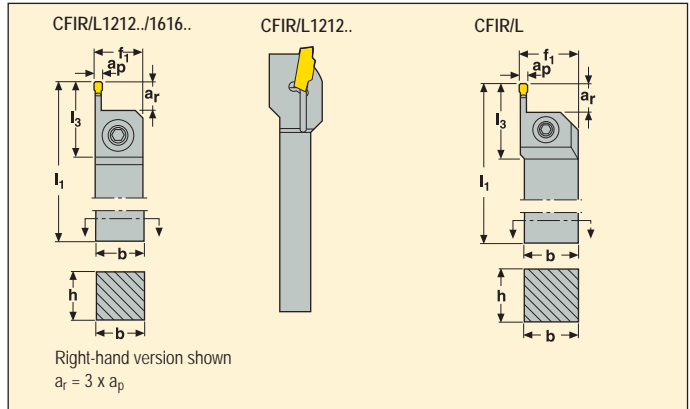

Part No.	Dimensions in mm							DCINN3*	KG	Seat size	Insert
	h	b	l ₁	f ₁	l ₃	a _r					
3	CFIR 1212M03	12	12	150	12,0	31,0	9	-	0,2	3	LC..1603..
	1616H03	16	16	100	16,0	28,0	9	-	0,2	3	LC..1603..
	2020K03	20	20	125	21,5	28,0	9	-	0,4	3	LC..1603..
	2525M03	25	25	150	26,5	28,0	9	195	0,7	3	LC..1603..
	3225P03	32	25	170	26,5	28,0	9	195	1,0	3	LC..1603..
	CFIL 1212M03	12	12	150	12,0	31,0	9	-	0,2	3	LC..1603..
	1616H03	16	16	100	16,0	28,0	9	-	0,2	3	LC..1603..
	2020K03	20	20	125	21,5	28,0	9	-	0,4	3	LC..1603..
	2525M03	25	25	150	26,5	28,0	9	195	0,7	3	LC..1603..
	3225P03	32	25	170	26,5	28,0	9	195	1,0	3	LC..1603..
4	CFIR 1212M04	12	12	150	12,0	33,0	12	-	0,2	4	LC..1604..
	1616H04	16	16	100	16,0	31,0	12	-	0,2	4	LC..1604..
	2020K04	20	20	125	21,5	31,0	12	-	0,4	4	LC..1604..
	2525M04	25	25	150	26,5	31,0	12	195	0,7	4	LC..1604..
	3225P04	32	25	170	26,5	31,0	12	195	1,0	4	LC..1604..
	CFIL 1212M04	12	12	150	12,0	33,0	12	-	0,2	4	LC..1604..
	1616H04	16	16	100	16,0	31,0	12	-	0,2	4	LC..1604..
	2020K04	20	20	125	21,5	31,0	12	-	0,4	4	LC..1604..
	2525M04	25	25	150	26,5	31,0	12	195	0,7	4	LC..1604..
	3225P04	32	25	170	26,5	31,0	12	195	1,0	4	LC..1604..

*DCINN3 – minimum bore diameter for internal application, see page(s) 477.

Spare Parts, Parts included in delivery

For holder	Clamp key	Clamp screw	Torque value Nm
..1212M03	3SMS795	TCEI0409	2,5
..1616H03	4SMS795	TCEI0509	6,0
..2020K03	4SMS795	TCEI0513	6,0
..2525M03	4SMS795	TCEI0513	6,0
..3225P03	4SMS795	TCEI0513	6,0
..1212M04	3SMS795	TCEI0409	3,5
..1616H04	5SMS795	TCEI0609	8,0
..2020K04	5SMS795	TCEI0613	8,0
..2525M04	5SMS795	TCEI0613	8,0
..3225P04	5SMS795	TCEI0613	8,0

Please check availability in current price and stock-list

Toolholders for inserts LCGF, LCGN, LCMF and LCMR



- For insert programme, see page(s) 578-589, 593-594

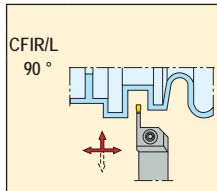
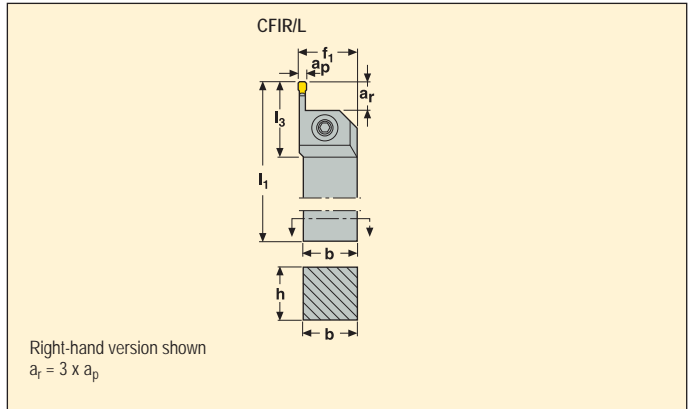

	Part No.	Dimensions in mm							KG	Seat size	
		h	b	l ₁	f ₁	l ₃	a _r **	DCINN3*			
5	CFIR 2020K05	20	20	125	21,5	35,0	15	–	0,4	5	LC..1605..
	2525M05	25	25	150	26,5	35,0	15	195	0,7	5	LC..1605..
	3225P05	32	25	170	26,5	35,0	15	195	1,0	5	LC..1605..
	CFIL 2020K05	20	20	125	21,5	35,0	15	–	0,4	5	LC..1605..
	2525M05	25	25	150	26,5	35,0	15	195	0,7	5	LC..1605..
	3225P05	32	25	170	26,5	35,0	15	195	1,0	5	LC..1605..
6	CFIR 2020K06	20	20	125	21,5	42,0	18	–	0,4	6	LC..1606..
	2525M06	25	25	150	26,5	42,0	18	195	0,7	6	LC..1606..
	3225P06	32	25	170	26,5	42,0	18	195	1,0	6	LC..1606..
	CFIL 2020K06	20	20	125	21,5	42,0	18	–	0,4	6	LC..1606..
	2525M06	25	25	150	26,5	42,0	18	195	0,7	6	LC..1606..
	3225P06	32	25	170	26,5	42,0	18	195	1,0	6	LC..1606..
8	CFIR 2525M08	25	25	150	28,0	55,0	24	195	0,7	8	LC..3008..
	3225P08	32	25	170	28,0	55,0	24	195	1,0	8	LC..3008..
	CFIL 2525M08	25	25	150	28,0	55,0	24	195	0,7	8	LC..3008..
	3225P08	32	25	170	28,0	55,0	24	195	1,0	8	LC..3008..

*DCINN3 – minimum bore diameter for internal application, see page(s) 477.

**Max depth of cut for LCGF/LCMF16.. = 14 mm

Spare Parts, Parts included in delivery

For holder	Clamp key	Clamp screw	Torque value Nm
CFIR/L...-05	5SMS795	TCEI0613	8,0
CFIR/L...-06	6SMS795	TCEI0815	10,0
CFIR/L...-08	6SMS795	TCEI1020	15,0

Please check availability in current price and stock-list

Toolholders for inserts LCGF, LCGN, LCMF and LCMR



• For insert programme, see page(s) 578-591, 593-594

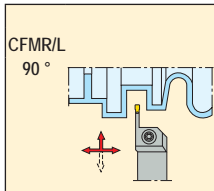
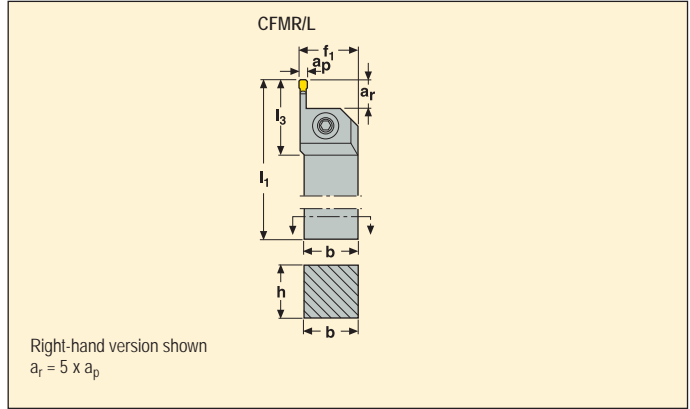

	Part No.	Dimensions in mm							KG	Seat size	
		h	b	l ₁	f ₁	l ₃	a _r **	DCINN3*			
3	CFMR 2020K03	20	20	125	21,5	36,0	15	–	0,4	3	LC..1603..
	2525M03	25	25	150	26,5	36,0	15	195	0,7	3	LC..1603..
	3225P03	32	25	170	26,5	36,0	15	195	1,0	3	LC..1603..
	CFML 2020K03	20	20	125	21,5	36,0	15	–	0,4	3	LC..1603..
	2525M03	25	25	150	26,5	36,0	15	195	0,7	3	LC..1603..
	3225P03	32	25	170	26,5	36,0	15	195	1,0	3	LC..1603..
4	CFMR 2020K04	20	20	125	21,5	39,0	20	–	0,4	4	LC..1604..
	2525M04	25	25	150	26,5	41,0	20	195	0,7	4	LC..1604..
	3225P04	32	25	170	26,5	41,0	20	195	1,0	4	LC..1604..
	CFML 2020K04	20	20	125	21,5	39,0	20	–	0,4	4	LC..1604..
	2525M04	25	25	150	26,5	41,0	20	195	0,7	4	LC..1604..
	3225P04	32	25	170	26,5	41,0	20	195	1,0	4	LC..1604..

*DCINN3 – minimum bore diameter for internal application, see page(s) 477.

**Max depth of cut for LCGF/LCMF16.. = 14 mm

Spare Parts, Parts included in delivery

For holder	Clamp key	Clamp screw	Torque value Nm
CFIR/L...03	4SMS795	TCEI0513	6,0
CFIR/L...04	5SMS795	TCEI0613	8,0

Please check availability in current price and stock-list

Toolholders for inserts LCGF, LCGN, LCMF and LCMR



- For insert programme, see page(s) 578-589, 593-594

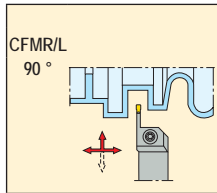
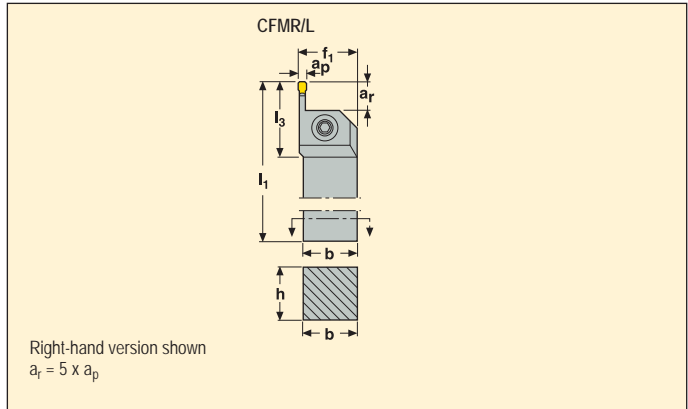

	Part No.	Dimensions in mm							KG	Seat size	
		h	b	l ₁	f ₁	l ₃	a _r **	DCINN3*			
5	CFMR 2020K05	20	20	125	21,5	50,0	25	-	0,4	5	LC..1605..
	2525M05	25	25	150	26,5	50,0	25	195	0,7	5	LC..1605..
	3225P05	32	25	170	26,5	50,0	25	195	1,0	5	LC..1605..
	CFML 2020K05	20	20	125	21,5	50,0	25	-	0,4	5	LC..1605..
	2525M05	25	25	150	26,5	50,0	25	195	0,7	5	LC..1605..
	3225P05	32	25	170	26,5	50,0	25	195	1,0	5	LC..1605..
6	CFMR 2020M06	20	20	150	21,5	60,0	30	-	0,5	6	LC..1606..
	2525M06	25	25	150	26,5	60,0	30	195	0,7	6	LC..1606..
	3225P06	32	25	170	26,5	60,0	30	195	1,0	6	LC..1606..
	CFML 2020M06	20	20	150	21,5	60,0	30	-	0,5	6	LC..1606..
	2525M06	25	25	150	26,5	60,0	30	195	0,7	6	LC..1606..
	3225P06	32	25	170	26,5	60,0	30	195	1,0	6	LC..1606..
8	CFMR 2525P08	25	25	170	28,0	74,0	40	195	0,8	8	LC..3008..
	3225P08	32	25	170	28,0	74,0	40	195	1,0	8	LC..3008..
	CFML 2525P08	25	25	170	28,0	74,0	40	195	0,8	8	LC..3008..
	3225P08	32	25	170	28,0	74,0	40	195	0,9	8	LC..3008..

*DCINN3 – minimum bore diameter for internal application, see page(s) 477.

**Max depth of cut for LCGF/LCMF16.. = 14 mm, LCGF/LCMF30.. = 28

Spare Parts, Parts included in delivery

For holder	Clamp key	Clamp screw	Torque value Nm
CFIR/L...-05	5SMS795	TCEI0613	8,0
CFIR/L...-06	6SMS795	TCEI0815	10,0
CFIR/L...-08	6SMS795	TCEI1020	15,0

Please check availability in current price and stock-list

Toolholders for inserts LCGN and LCMR



• For insert programme, see page(s) 578-591, 593-594

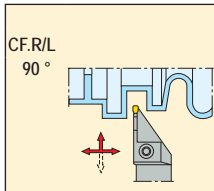
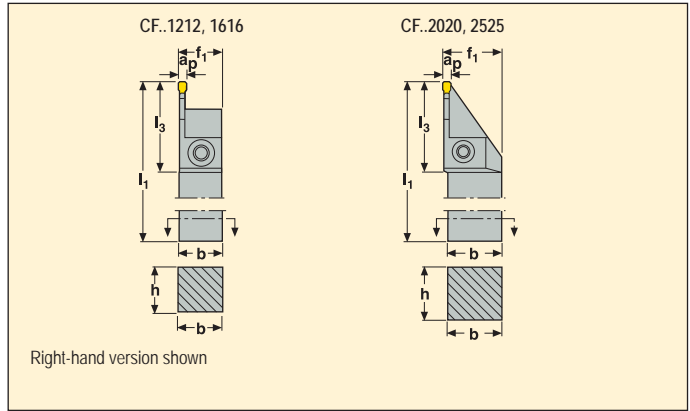

	Part No.	Dimensions in mm						KG	Seat size	
		h	b	l ₁	f ₁	l ₃	D _m *			
3	CFOR 1212M03	12	12	150	12,0	32,1	37	0,2	3	LC..1603..
	CFOL 1212M03	12	12	150	12,0	32,1	37	0,2	3	LC..1603..
3	CFTR 1616M03	16	16	150	16,0	42,0	50	0,3	3	LC..1603..
	2020K03	20	20	125	21,5	43,0	50	0,4	3	LC..1603..
	2525M03	25	25	150	26,5	42,5	50	0,7	3	LC..1603..
	CFTL 1616M03	16	16	150	16,0	42,0	50	0,3	3	LC..1603..
	2020K03	20	20	125	21,5	43,0	50	0,4	3	LC..1603..
	2525M03	25	25	150	26,5	42,5	50	0,7	3	LC..1603..
4	CFPR 2020K04	20	20	125	21,5	43,0	50	0,4	4	LC..1604..
	2525M04	25	25	150	26,5	43,0	50	0,7	4	LC..1604..
	CFPL 2020K04	20	20	125	21,5	43,0	50	0,4	4	LC..1604..
	2525M04	25	25	150	26,5	43,0	50	0,7	4	LC..1604..

*Due to the design, grooving depth is limited, see page(s) 477.

Spare Parts, Parts included in delivery

For holder	Clamp key	Clamp screw	Torque value Nm
CFOR/L...03	3SMS795	TCEI0409	3,5
CFTR/L...03	4SMS795	TCEI0513	6,0
CFPR/L...04	5SMS795	TCEI0613	8,0

Please check availability in current price and stock-list

Toolholders for inserts LCMF



• For insert programme, see page(s) 577

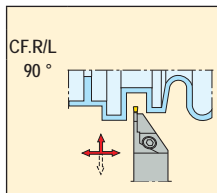
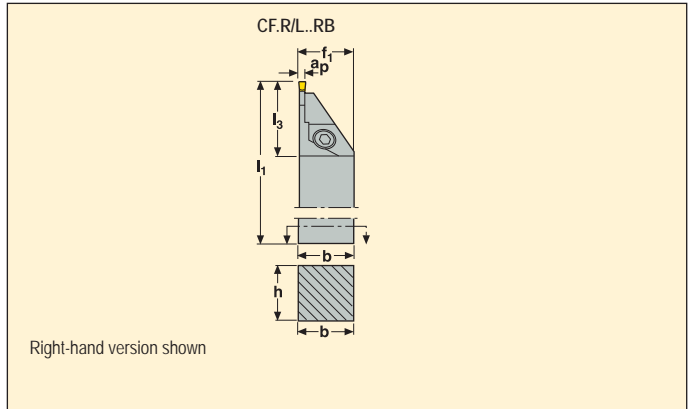

	Part No.	Dimensions in mm						KG	Seat size	
		h	b	l ₁	f ₁	l ₃	D _m *			
2	CFOR 1212K1902RB	12	12	125	12,0	22,0	25	0,2	2	LC..1902..
	1616K1902RB	16	16	125	16,0	22,0	25	0,3	2	LC..1902..
	CFOL 1212K1902RB	12	12	125	12,0	22,0	25	0,2	2	LC..1902..
	1616K1902RB	16	16	125	16,0	22,0	25	0,3	2	LC..1902..
2	CFSR 1212K1902RB	12	12	125	12,0	25,0	33	0,2	2	LC..1902..
	1616K1902RB	16	16	125	16,0	25,0	33	0,3	2	LC..1902..
	CFSL 1212K1902RB	12	12	125	12,0	25,0	33	0,2	2	LC..1902..
	1616K1902RB	16	16	125	16,0	25,0	33	0,3	2	LC..1902..

*Due to the design, grooving depth is limited, see page(s) 477.

Spare Parts, Parts included in delivery

For holder	Clamp key	Clamp screw	Torque value Nm
CFOR/L..19	T15P-7S	L85012-T15P	5,0
CFSR/L..19	T15P-7S	L85012-T15P	5,0

Please check availability in current price and stock-list

Toolholders for inserts LCGF, LCGN, LCMF and LCMR



- For insert programme, see page(s) 578-591, 593-594

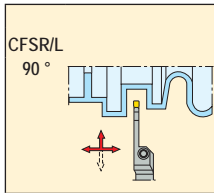
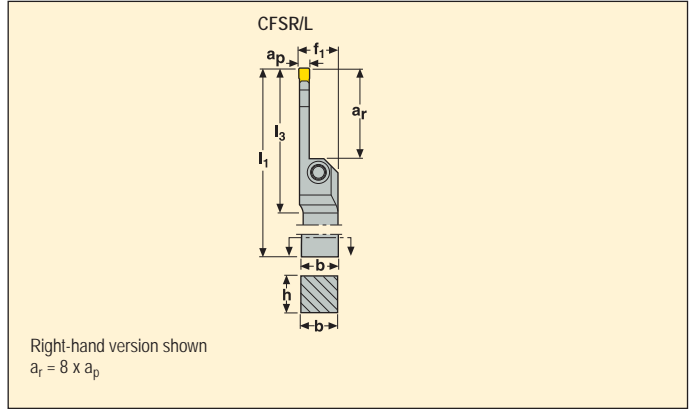

	Part No.	Dimensions in mm							KG	Seat size	
		h	b	l ₁	f ₁	l ₃	a _r **	DCINN3*			
3	CFSR 2525M03	25	25	150	26,5	46,0	24	195	0,7	3	LC..1603..
	3225P03	32	25	170	26,1	46,0	24	195	1,0	3	LC..1603..
	CFSL 2525M03	25	25	150	26,5	46,0	24	195	0,7	3	LC..1603..
	3225P03	32	25	170	26,1	46,0	24	195	1,0	3	LC..1603..
4	CFSR 2525P04	25	25	170	26,5	55,0	32	195	0,6	4	LC..1604..
	3225P04	32	25	170	26,5	55,0	32	195	0,9	4	LC..1604..
	CFSL 2525P04	25	25	170	26,5	55,0	32	195	0,7	4	LC..1604..
	3225P04	32	25	170	26,5	55,0	32	195	0,9	4	LC..1604..
5	CFSR 2525P05	25	25	170	26,5	66,0	40	195	0,7	5	LC..1605..
	3225P05	32	25	170	26,5	66,0	40	195	0,9	5	LC..1605..
	CFSL 2525P05	25	25	170	26,5	66,0	40	195	0,7	5	LC..1605..
	3225P05	32	25	170	26,5	66,0	40	195	0,9	5	LC..1605..
6	CFSR 2525R06	25	25	200	26,5	81,0	48	195	0,8	6	LC..1606..
	3225R06	32	25	200	26,5	81,0	48	195	1,1	6	LC..1606..
	CFSL 2525R06	25	25	200	26,5	81,0	48	195	0,8	6	LC..1606..
	3225R06	32	25	200	26,5	81,0	48	195	1,1	6	LC..1606..
8	CFSR 3225R08	32	25	200	28,0	104,0	64	195	1,0	8	LC..3008..
	CFSL 3225R08	32	25	200	28,0	104,0	64	195	1,0	8	LC..3008..

*DCINN3 – minimum bore diameter for internal application, see page(s) 477.

**Max depth of cut for LCGF/LCMF16.. = 14 mm, LCGF/LCMF30.. = 28 mm

Spare Parts, Parts included in delivery

For holder	Clamp key	Clamp screw	Torque value Nm
CFSR/L..03	4SMS795	TCEI0513	6,0
CFSR/L..04	5SMS795	TCEI0613	8,0
CFSR/L..05	5SMS795	TCEI0613	8,0
CFSR/L..06	6SMS795	TCEI0815	10,0
CFSR/L..08	6SMS795	TCEI1020	15,0

Please check availability in current price and stock-list

Toolholders for inserts LCMF



• For insert programme, see page(s) 577

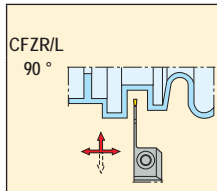
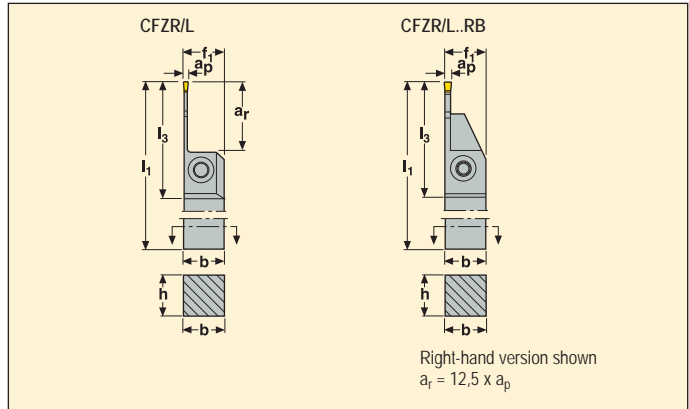

	Part No.	Dimensions in mm							KG	Seat size	
		h	b	l ₁	f ₁	l ₃	a _r	D _m *			
2	CFZR 1616M2802	16	16	150	16,0	46,0	26	–	0,3	2	LC..2802..
	CFZL 1616M2802	16	16	150	16,0	46,0	26	–	0,3	2	LC..2802..
2	CFZR 1616M2802RB	16	16	150	16,0	46,0	–	52	0,3	2	LC..2802..
	CFZL 1616M2802RB	16	16	150	16,0	46,0	–	52	0,3	2	LC..2802..

*Due to the design, grooving depth is limited, see page(s) 477.

Spare Parts, Parts included in delivery

For holder	Clamp key	Clamp screw	Torque value Nm
CFZR/L..02	4SMS795	TCEI0513	6,0

Please check availability in current price and stock-list

Toolholders for inserts LCGF, LCGN, LCMF and LCMR



• For insert programme, see page(s) 578-583, 593-594

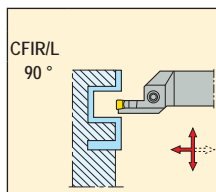
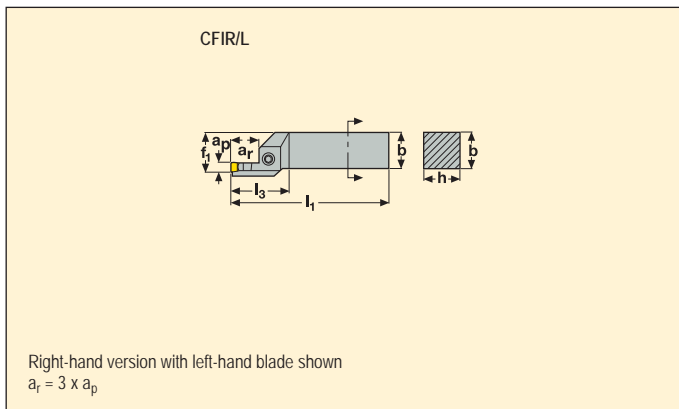

	Part No.	Dimensions in mm								KG	Seat size	
		INPLM	INPLX	h	b	l ₁	f ₁	l ₃	a _r			
3	CFIR2525M03L100070	70	100	25	25	150	26,5	28,0	9	0,7	3	LC..1603..
	CFIR2525M03L130090	90	130	25	25	150	26,5	28,0	9	0,7	3	LC..1603..
	CFIR2525M03L170110	110	170	25	25	150	26,5	28,0	9	0,7	3	LC..1603..
	CFIL2525M03R100070	70	100	25	25	150	26,5	28,0	9	0,7	3	LC..1603..
	CFIL2525M03R130090	90	130	25	25	150	26,5	28,0	9	0,7	3	LC..1603..
	CFIL2525M03R170110	110	170	25	25	150	26,5	28,0	9	0,7	3	LC..1603..
4	CFIR2525M04L100070	70	100	25	25	150	26,5	31,0	12	0,7	4	LC..1604..
	CFIR2525M04L130090	90	130	25	25	150	26,5	31,0	12	0,7	4	LC..1604..
	CFIR2525M04L170110	110	170	25	25	150	26,5	31,0	12	0,7	4	LC..1604..
	CFIR2525M04L230140	140	230	25	25	150	26,5	31,0	12	0,7	4	LC..1604..
	CFIL2525M04R100070	70	100	25	25	150	26,5	31,0	12	0,7	4	LC..1604..
	CFIL2525M04R130090	90	130	25	25	150	26,5	31,0	12	0,7	4	LC..1604..
	CFIL2525M04R170110	110	170	25	25	150	26,5	31,0	12	0,7	4	LC..1604..
	CFIL2525M04R230140	140	230	25	25	150	26,5	31,0	12	0,7	4	LC..1604..

Initial plunge (INPLM/INPLX) relates to face groove diameter, see page(s) 477.

Spare Parts, Parts included in delivery

For holder	Clamp key	Clamp screw	Torque value Nm
CFIR/L..03	4SMS795	TCEI0513	6,0
CFIR/L..04	5SMS795	TCEI0613	8,0

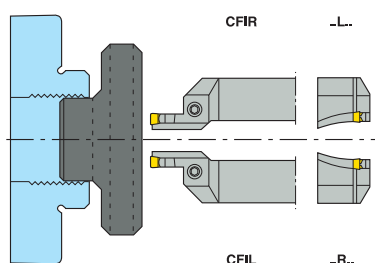

Please check availability in current price and stock-list

Toolholders for inserts LCGF, LCGN, LCMF and LCMR



- For insert programme, see page(s) 578-583, 593-594

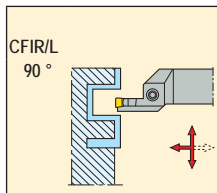
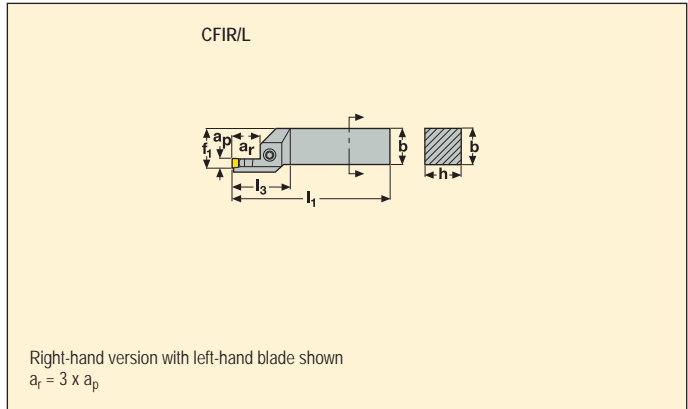

Part No.	Dimensions in mm									KG	Seat size	Insert
	INPLM	INPLX	h	b	l ₁	f ₁	l ₃	a _r **				
5	CFIR2525M05L100070	70	100	25	25	150	26,5	35,0	15	0,7	5	LC..1605..
	CFIR2525M05L130090	90	130	25	25	150	26,5	35,0	15	0,7	5	LC..1605..
	CFIR2525M05L170110	110	170	25	25	150	26,5	35,0	15	0,7	5	LC..1605..
	CFIR2525M05L230140	140	230	25	25	150	26,5	35,0	15	0,7	5	LC..1605..
	CFIL2525M05R100070	70	100	25	25	150	26,5	35,0	15	0,7	5	LC..1605..
	CFIL2525M05R130090	90	130	25	25	150	26,5	35,0	15	0,7	5	LC..1605..
	CFIL2525M05R170110	110	170	25	25	150	26,5	35,0	15	0,7	5	LC..1605..
	CFIL2525M05R230140	140	230	25	25	150	26,5	35,0	15	0,7	5	LC..1605..
6	CFIR2525M06L100070	70	100	25	25	150	26,5	42,0	18	0,7	6	LC..1606..
	CFIR2525M06L130090	90	130	25	25	150	26,5	42,0	18	0,7	6	LC..1606..
	CFIR2525M06L170110	110	170	25	25	150	26,5	42,0	18	0,7	6	LC..1606..
	CFIR2525M06L230140	140	230	25	25	150	26,5	42,0	18	0,7	6	LC..1606..
	CFIL2525M06R100070	70	100	25	25	150	26,5	42,0	18	0,7	6	LC..1606..
	CFIL2525M06R130090	90	130	25	25	150	26,5	42,0	18	0,7	6	LC..1606..
	CFIL2525M06R170110	110	170	25	25	150	26,5	42,0	18	0,7	6	LC..1606..
	CFIL2525M06R230140	140	230	25	25	150	26,5	42,0	18	0,7	6	LC..1606..

Initial plunge (INPLM/INPLX) relates to face groove diameter, see page(s) 477.

**Max depth of cut for LCGF/LCMF16.. = 14 mm

Spare Parts, Parts included in delivery

For holder	Clamp key	Clamp screw	Torque value Nm
CFIR/L..05	5SMS795	TCEI0613	8,0
CFIR/L..06	6SMS795	TCEI0815	10,0

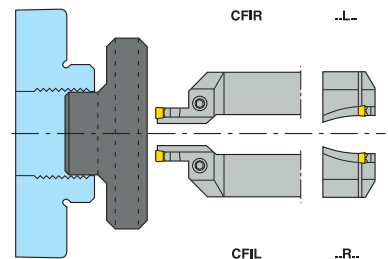

Please check availability in current price and stock-list

Toolholders for inserts LCGF, LCGN, LCMF and LCMR



• For insert programme, see page(s) 578-583, 593-594

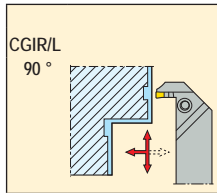
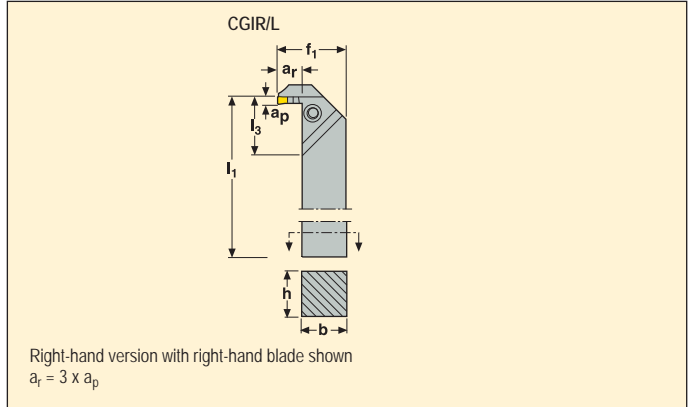

Part No.	Dimensions in mm								KG	Seat size	Image	
	INPLM	INPLX	h	b	l ₁	f ₁	l ₃	a _r				
3	CGIR2525M03R100070	70	100	25	25	150	35,4	33,0	9	0,8	3	LC..1603..
	CGIR2525M03R130090	90	130	25	25	150	35,4	33,0	9	0,8	3	LC..1603..
	CGIR2525M03R170110	110	170	25	25	150	35,4	33,0	9	0,8	3	LC..1603..
	CGIL2525M03L100070	70	100	25	25	150	35,4	33,0	9	0,8	3	LC..1603..
	CGIL2525M03L130090	90	130	25	25	150	35,4	33,0	9	0,8	3	LC..1603..
	CGIL2525M03L170110	110	170	25	25	150	35,4	33,0	9	0,8	3	LC..1603..
4	CGIR2525M04R100070	70	100	25	25	150	38,4	33,0	12	0,8	4	LC..1604..
	CGIR2525M04R130090	90	130	25	25	150	38,4	33,0	12	0,8	4	LC..1604..
	CGIR2525M04R170110	110	170	25	25	150	38,4	33,0	12	0,9	4	LC..1604..
	CGIR2525M04R230140	140	230	25	25	150	38,4	33,0	12	0,8	4	LC..1604..
	CGIL2525M04L100070	70	100	25	25	150	38,4	33,0	12	0,8	4	LC..1604..
	CGIL2525M04L130090	90	130	25	25	150	38,4	33,0	12	0,8	4	LC..1604..
	CGIL2525M04L170110	110	170	25	25	150	38,4	33,0	12	0,8	4	LC..1604..
	CGIL2525M04L230140	140	230	25	25	150	38,4	33,0	12	0,8	4	LC..1604..

Initial plunge (INPLM/INPLX) relates to face groove diameter, see page(s) 477.

Spare Parts, Parts included in delivery

For holder	Clamp key	Clamp screw	Torque value Nm
CGIR/L...03	4SMS795	TCEI0513	6,0
CGIR/L...04	5SMS795	TCEI0613	8,0

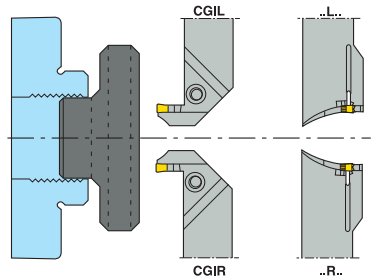

Please check availability in current price and stock-list

Toolholders for inserts LCGF, LCGN, LCMF and LCMR



• For insert programme, see page(s) 578-583, 593-594

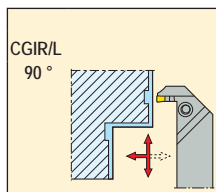
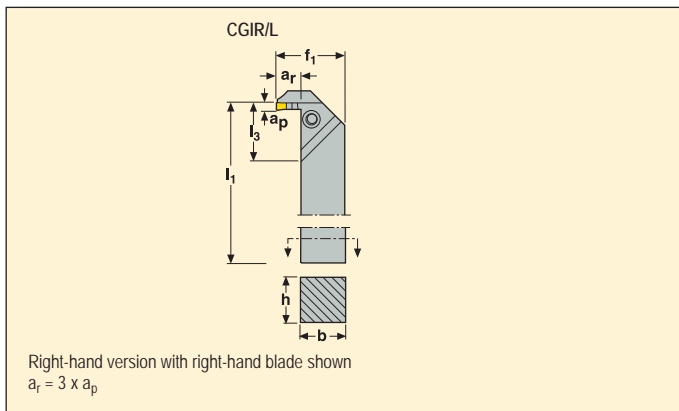

Part No.	Dimensions in mm									KG	Seat size	Insert
	INPLM	INPLX	h	b	l ₁	f ₁	l ₃	a _r **				
5	CGIR2525M05R100070	70	100	25	25	150	41,4	33,0	15	0,8	5	LC..1605..
	CGIR2525M05R130090	90	130	25	25	150	41,4	33,0	15	0,8	5	LC..1605..
	CGIR2525M05R170110	110	170	25	25	150	41,4	33,0	15	0,8	5	LC..1605..
	CGIR2525M05R230140	140	230	25	25	150	41,4	33,0	15	0,8	5	LC..1605..
	CGIL2525M05L100070	70	100	25	25	150	41,4	33,0	15	0,8	5	LC..1605..
	CGIL2525M05L130090	90	130	25	25	150	41,4	33,0	15	0,8	5	LC..1605..
	CGIL2525M05L170110	110	170	25	25	150	41,4	33,0	15	0,8	5	LC..1605..
	CGIL2525M05L230140	140	230	25	25	150	41,4	33,0	15	0,8	5	LC..1605..
6	CGIR2525M06R100070	70	100	25	25	150	44,4	34,0	18	0,8	6	LC..1606..
	CGIR2525M06R130090	90	130	25	25	150	44,4	34,0	18	0,8	6	LC..1606..
	CGIR2525M06R170110	110	170	25	25	150	44,4	34,0	18	0,8	6	LC..1606..
	CGIR2525M06R230140	140	230	25	25	150	44,4	34,0	18	0,8	6	LC..1606..
	CGIL2525M06L100070	70	100	25	25	150	44,4	34,0	18	0,8	6	LC..1606..
	CGIL2525M06L130090	90	130	25	25	150	44,4	34,0	18	0,8	6	LC..1606..
	CGIL2525M06L170110	110	170	25	25	150	44,4	34,0	18	0,8	6	LC..1606..
	CGIL2525M06L230140	140	230	25	25	150	44,4	34,0	18	0,8	6	LC..1606..

Initial plunge (INPLM/INPLX) relates to face groove diameter, see page(s) 477.

**Max depth of cut for LCGF/LCMF16.. = 14 mm

Spare Parts, Parts included in delivery

For holder	Clamp key	Clamp screw	Torque value Nm
CGIR/L..05	5SMS795	TCEI0613	8,0
CGIR/L..06	6SMS795	TCEI0815	10,0

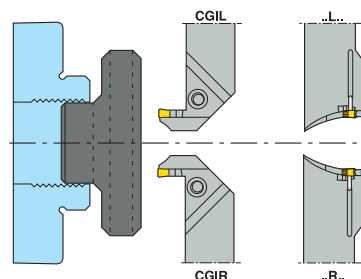

Please check availability in current price and stock-list

Toolholders for inserts LCGA, LCGF, LCGN, LCMF and LCMR



• For insert programme, see page(s) 573-576, 592

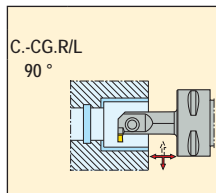
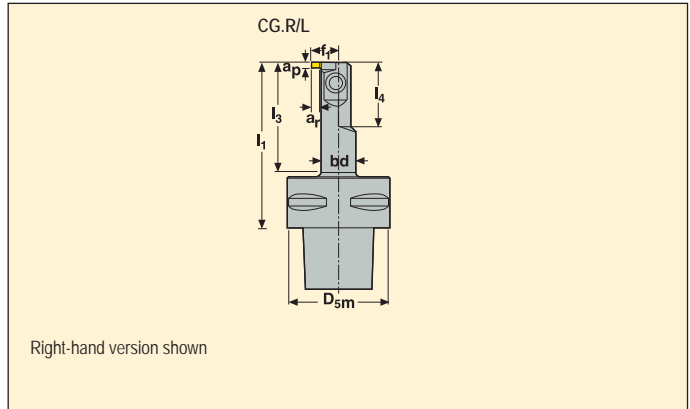

Capto size	Part No.	Dimensions in mm									KG	Seat size			
		bd	D _{5m}	f ₁	l ₁	l ₃	l ₄	a _r	DCINN*						
C4	3	C4-CGER -11065-1303	14	40	10,2	65	43,0	26	3,0	16	0,3	3	LC..1303..		
		C4-CGEL -11065-1303	14	40	10,2	65	43,0	26	3,0	16	0,3	3	LC..1303..		
		C4-CGFR -15075-1303	18	40	14,5	75	53,0	31	5,5	20	0,4	3	LC..1303..		
		C4-CGFL -15075-1303	18	40	14,5	75	53,0	31	5,5	20	0,4	3	LC..1303..		
	4	C4-CGFR -15075-1304	18	40	14,5	75	53,0	31	5,5	20	0,4	4	LC..1304..		
		C4-CGFL -15075-1304	18	40	14,5	75	53,0	31	5,5	20	0,4	4	LC..1304..		
		C5	3	C5-CGER -11065-1303	14	50	10,2	65	43,0	26	3,0	16	0,5	3	LC..1303..
				C5-CGEL -11065-1303	14	50	10,2	65	43,0	26	3,0	16	0,5	3	LC..1303..
C5-CGFR -15075-1303	18			50	14,5	75	53,0	31	5,5	20	0,5	3	LC..1303..		
C5-CGFL -15075-1303	18			50	14,5	75	53,0	31	5,5	20	0,5	3	LC..1303..		
C5-CGHR -19080-1303	23			50	19,0	80	58,0	41	7,5	25	0,9	3	LC..1303..		
C5-CGHL -19080-1303	23			50	19,0	80	58,0	41	7,5	25	0,9	3	LC..1303..		
C5-CGJR -26110-1303	30			50	25,5	110	88,0	51	10,5	32	0,9	3	LC..1303..		
C5-CGJL -26110-1303	30			50	25,5	110	88,0	51	10,5	32	0,9	3	LC..1303..		
4	C5-CGFR -15075-1304	18	50	14,5	75	53,0	31	5,5	20	0,5	4	LC..1304..			
	C5-CGFL -15075-1304	18	50	14,5	75	53,0	31	5,5	20	0,5	4	LC..1304..			
	C5-CGFR -19080-1304	23	50	19,0	80	58,0	41	7,5	25	0,6	4	LC..1304..			
	C5-CGFL -19080-1304	23	50	19,0	80	58,0	41	7,5	25	0,6	4	LC..1304..			
	C5-CGHR -26110-1304	30	50	25,5	110	88,0	51	10,5	32	0,9	4	LC..1304..			
	C5-CGHL -26110-1304	30	50	25,5	110	88,0	51	10,5	32	0,9	4	LC..1304..			

*DCINN – minimum bore diameter, see page(s) 477

Spare Parts, Parts included in delivery

For holder	Clamp key	Clamp screw	Torque value Nm
CG.R/L...-1303	T15P-7	L85011-T15P	5,0
CG.R/L...-1304	T15P-7	L85011-T15P	5,0

Please check availability in current price and stock-list

Toolholders for inserts LCGA, LCGF, LCGN, LCMF and LCMR



• For insert programme, see page(s) 573-576, 592

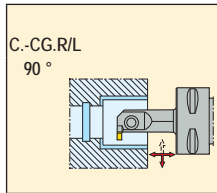
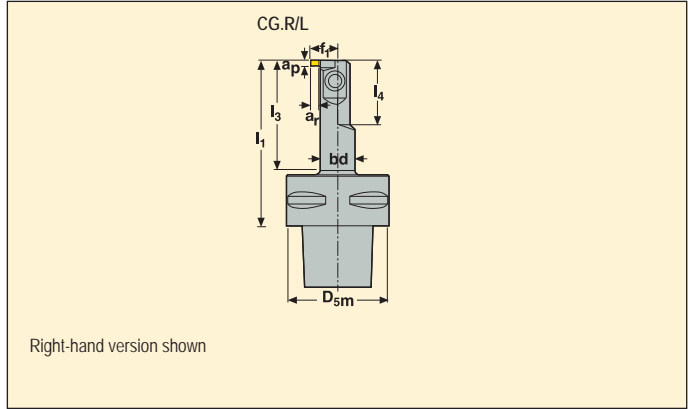

Capto size	Part No.	Dimensions in mm								KG	Seat size	Insert	
		bd	D _{sm}	f ₁	l ₁	l ₃	l ₄	a _r	DCINN*				
C6	3	C6-CGER -11065-1303	14	63	10,2	65	43,0	26	3,0	16	0,8	3	LC..1303..
		C6-CGEL -11065-1303	14	63	10,2	65	43,0	26	3,0	16	0,8	3	LC..1303..
		C6-CGFR -15075-1303	18	63	14,5	75	53,0	31	5,5	20	0,9	3	LC..1303..
		C6-CGFL -15075-1303	18	63	14,5	75	53,0	31	5,5	20	0,9	3	LC..1303..
		C6-CGHR -19080-1303	23	63	19,0	80	56,0	41	7,5	25	0,9	3	LC..1303..
		C6-CGHL -19080-1303	23	63	19,0	80	58,0	40	7,5	25	1,5	3	LC..1303..
		C6-CGJR -26110-1303	30	63	25,5	110	86,0	50	10,5	32	1,1	3	LC..1303..
	C6-CGJL -26110-1303	30	63	25,5	110	86,0	50	10,5	32	1,5	3	LC..1303..	
	4	C6-CGFR -19080-1304	23	63	19,0	80	58,0	41	7,5	25	0,9	4	LC..1304..
		C6-CGFL -15075-1304	18	63	14,5	75	53,0	31	5,5	20	0,9	4	LC..1304..
		C6-CGFL -19080-1304	23	63	19,0	80	58,0	41	7,5	25	0,9	4	LC..1304..
		C6-CGFL -15075-1304	18	63	14,5	75	53,0	31	5,5	20	0,9	4	LC..1304..
		C6-CGHR -26110-1304	30	63	25,5	110	86,0	51	10,5	32	1,1	4	LC..1304..
		C6-CGHL -26110-1304	30	63	25,5	110	88,0	50	10,5	32	1,5	4	LC..1304..

*DCINN – minimum bore diameter, see page(s) 477

Spare Parts, Parts included in delivery

For holder	Clamp key	Clamp screw	Torque value Nm
CG.R/L...1303	T15P-7	L85011-T15P	5,0
CG.R/L...1304	T15P-7	L85011-T15P	5,0

Please check availability in current price and stock-list

Toolholders for inserts LCGF, LCGN, LCMF and LCMR

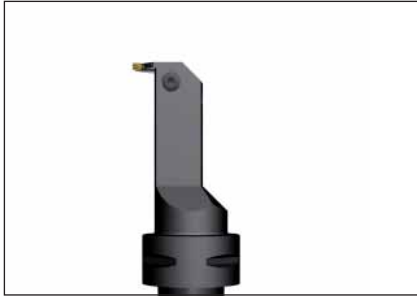

- For insert programme, see page(s) 578-591, 593-594

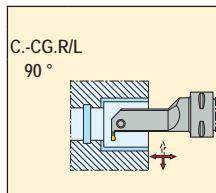
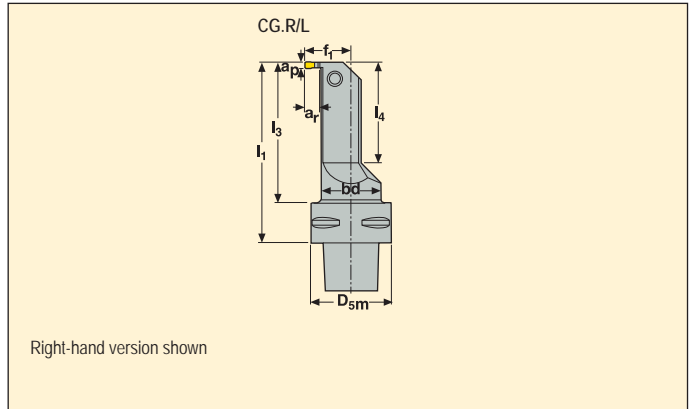

Capto size	Part No.	Dimensions in mm									KG	Seat size	Insert
		bd	D _{5m}	f ₁	l ₁	l ₃	l ₄	a _r	DCINN*				
C4	C4-CGIR -24090-1603	30	40	24,0	90	68,0	50	9,0	32	0,5	3	LC..1603..	
	C4-CGIL -24090-1603	30	40	24,0	90	68,0	50	9,0	32	0,5	3	LC..1603..	
	C4-CGGR -24090-1604	30	40	24,0	90	68,0	50	9,0	32	0,5	4	LC..1604..	
	C4-CGGL -24090-1604	30	40	24,0	90	68,0	50	9,0	32	0,5	4	LC..1604..	
	C4-CGFL -24090-1605	30	40	24,0	90	68,0	51	9,0	32	0,5	5	LC..1605..	
	C4-CGFR -24090-1605	30	40	24,0	90	68,0	50	9,0	32	0,5	5	LC..1605..	
C5	C5-CGIR -24090-1603	30	50	24,0	90	68,0	50	9,0	32	0,9	3	LC..1603..	
	C5-CGIL -24090-1603	30	50	24,0	90	68,0	50	9,0	32	0,9	3	LC..1603..	
	C5-CGGR -24090-1604	30	50	24,0	90	68,0	50	9,0	32	0,9	4	LC..1604..	
	C5-CGGL -24090-1604	30	50	24,0	90	68,0	50	9,0	32	0,9	4	LC..1604..	
	C5-CGFR -24090-1605	30	50	24,0	90	68,0	50	9,0	32	0,9	5	LC..1605..	
	C5-CGFL -24090-1605	30	50	24,0	90	68,0	50	9,0	32	0,9	5	LC..1605..	
	C5-CGFR -24090-1606	30	50	24,0	90	68,0	50	9,0	32	0,9	6	LC..1606..	
	C5-CGFL -24090-1606	30	50	24,0	90	68,0	50	9,0	32	0,9	6	LC..1606..	

*DCINN – minimum bore diameter, see page(s) 477

Spare Parts, Parts included in delivery

For holder	Clamp key	Clamp screw	Torque value Nm
CG.R/L...-1603	T15P-7	L85011-T15P	5,0
CG.R/L...-1604	T15P-7	L85011-T15P	5,0
CG.R/L...-1605	T20P-7	L86015-T20P	6,0
CG.R/L...-1606	T20P-7	L86015-T20P	6,0

Please check availability in current price and stock-list

Toolholders for inserts LCGF, LCGN, LCMF and LCMR



• For insert programme, see page(s) 578-591, 593-594

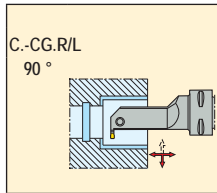
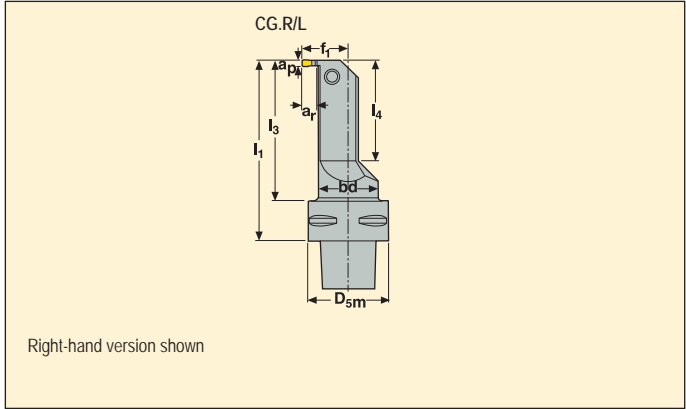

Capto size	Part No.	Dimensions in mm									KG	Seat size	Insert
		bd	D _{sm}	f ₁	l ₁	l ₃	l ₄	a _r	DCINN*				
C6	C6-CGIR -24095-1603	30	63	24,0	95	73,0	50	9,0	32	1,5	3	LC..1603..	
	C6-CGIL -24095-1603	30	63	24,0	95	73,0	50	9,0	32	1,5	3	LC..1603..	
4	C6-CGGR -24095-1604	30	63	24,0	95	73,0	50	9,0	32	1,5	4	LC..1604..	
	C6-CGGL -24095-1604	30	63	24,0	95	73,0	50	9,0	32	1,5	4	LC..1604..	
5	C6-CGFR -24095-1605	30	63	24,0	95	73,0	50	9,0	32	1,5	5	LC..1605..	
	C6-CGFL -24095-1605	30	63	24,0	95	73,0	50	9,0	32	1,5	5	LC..1605..	
6	C6-CGFR -24095-1606	30	63	24,0	95	73,0	50	9,0	32	1,5	6	LC..1606..	
	C6-CGFL -24095-1606	30	63	24,0	95	73,0	50	9,0	32	1,5	6	LC..1606..	

*DCINN – minimum bore diameter, see page(s) 477

Spare Parts, Parts included in delivery

For holder	Clamp key	Clamp screw	Torque value Nm
CG.R/L...-1603	T15P-7	L85011-T15P	5,0
CG.R/L...-1604	T15P-7	L85011-T15P	5,0
CG.R/L...-1605	T20P-7	L86015-T20P	6,0
CG.R/L...-1606	T20P-7	L86015-T20P	6,0

Please check availability in current price and stock-list

Toolholders for inserts LCGF, LCGN, LCMF and LCMR



• For insert programme, see page(s) 578-591, 593-594

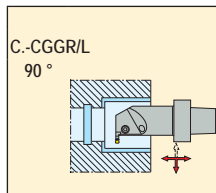
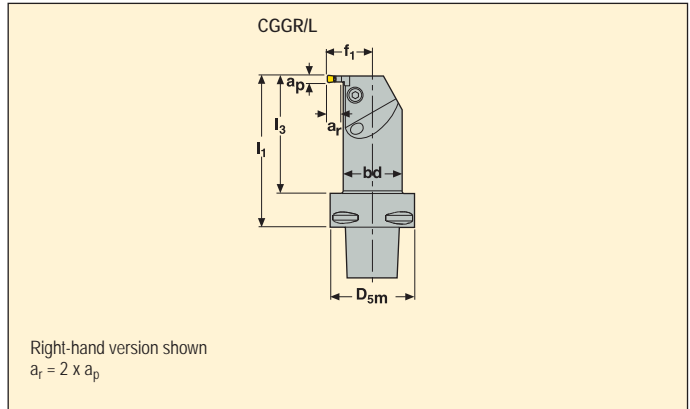

Capto size	Part No.	Dimensions in mm								KG	Seat size	
		bd	D _{5m}	f ₁	l ₁	l ₃	a _r	DCINN*				
C4	C4-CGGR -25090-03	35,0	40	25,0	90	70,0	6,0	45	0,7	3	LC..1603..	
	C4-CGGL -25090-03	35,0	40	25,0	90	70,0	6,0	45	0,7	3	LC..1603..	
	C4-CGGR -27090-04	35,0	40	27,0	90	70,0	8,0	45	0,7	4	LC..1604..	
	C4-CGGL -27090-04	35,0	40	27,0	90	70,0	8,0	45	0,7	4	LC..1604..	
	C4-CGGR -28090-05	32,5	40	27,7	90	63,0	10,0	45	0,5	5	LC..1605..	
	C4-CGGL -28090-05	32,5	40	27,7	90	63,0	10,0	45	0,5	5	LC..1605..	
C5	C5-CGGR -25090-03	35,0	50	25,0	90	70,0	6,0	45	0,9	3	LC..1603..	
	C5-CGGL -25090-03	35,0	50	25,0	90	70,0	6,0	45	0,9	3	LC..1603..	
	C5-CGGR -27090-04	35,0	50	27,0	90	70,0	8,0	45	0,9	4	LC..1604..	
	C5-CGGL -27090-04	35,0	50	27,0	90	70,0	8,0	45	0,9	4	LC..1604..	
	C5-CGGR -28090-05	32,5	50	27,7	90	63,0	10,0	45	0,9	5	LC..1605..	
	C5-CGGL -28090-05	32,5	50	27,7	90	63,0	10,0	45	0,9	5	LC..1605..	
	C5-CGGR -29090-06	30,5	50	28,7	90	62,0	12,0	45	0,9	6	LC..1606..	
	C5-CGGL -29090-06	30,5	50	28,7	90	62,0	12,0	45	0,9	6	LC..1606..	

*DCINN – minimum bore diameter, see page(s) 477

Spare Parts, Parts included in delivery

For holder	Clamp key	Clamp screw	Torque value Nm
CG.R/L...-03	3SMS795	MC6S4X14	3,5
CG.R/L...-04	4SMS795	MC6S5X14	5,0
CG.R/L...-05	4SMS795	MC6S5X14	5,0
CG.R/L...-06	5SMS795	TCEI0614	8,0

Please check availability in current price and stock-list

Toolholders for inserts LCGF, LCGN, LCMF and LCMR



• For insert programme, see page(s) 578-591, 593-594

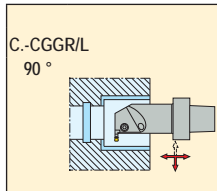
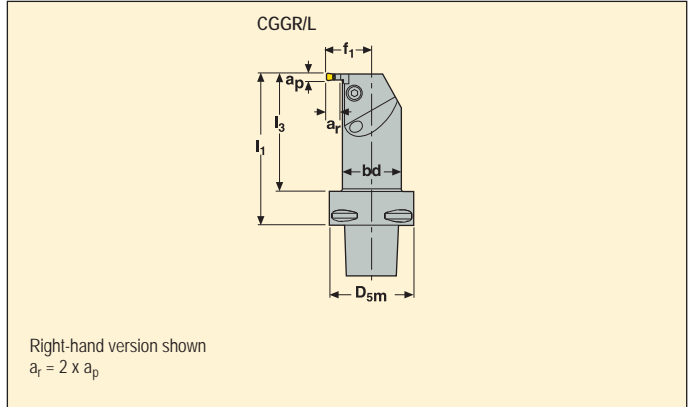

Capto size	Part No.	Dimensions in mm								KG	Seat size	Insert
		bd	D _{5m}	f ₁	l ₁	l ₃	a _r	DCINN*				
C6	C6-CGGR -25095-03	35,0	63	25,0	95	73,0	6,0	45	1,2	3	LC..1603..	
	C6-CGGL -25095-03	35,0	63	25,0	95	73,0	6,0	45	1,2	3	LC..1603..	
4	C6-CGGR -27095-04	35,0	63	27,0	95	73,0	8,0	45	1,2	4	LC..1604..	
	C6-CGGL -27095-04	35,0	63	27,0	95	73,0	8,0	45	1,2	4	LC..1604..	
5	C6-CGGR -28095-05	32,5	63	27,7	95	68,0	10,0	45	1,3	5	LC..1605..	
	C6-CGGL -28095-05	32,5	63	27,7	95	68,0	10,0	45	1,3	5	LC..1605..	
6	C6-CGGR -29095-06	30,5	63	28,7	95	67,0	12,0	45	1,1	6	LC..1606..	
	C6-CGGL -29095-06	30,5	63	28,7	95	67,0	12,0	45	1,3	6	LC..1606..	

*DCINN – minimum bore diameter, see page(s) 477

Spare Parts, Parts included in delivery

For holder	Clamp key	Clamp screw	Torque value Nm
CG.R/L...-03	3SMS795	MC6S4X14	3,5
CG.R/L...-04	4SMS795	MC6S5X14	5,0
CG.R/L...-05	4SMS795	MC6S5X14	5,0
CG.R/L...-06	5SMS795	TCEI0614	8,0

Please check availability in current price and stock-list

Toolholders for inserts LCMF



• For insert programme, see page(s) 577

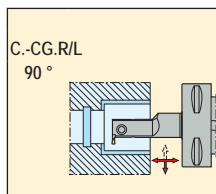
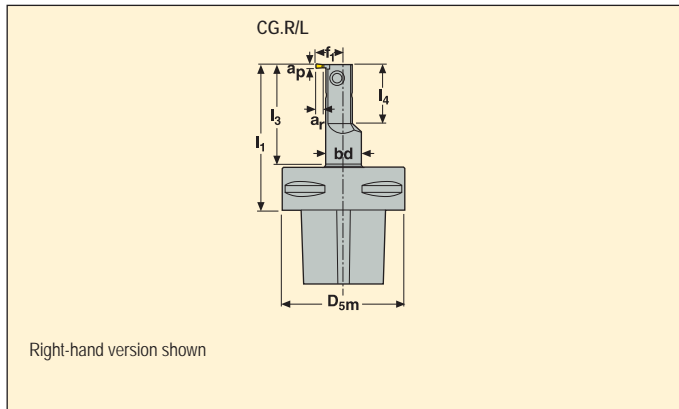

Capto size	Part No.	Dimensions in mm									KG	Seat size	
		bd	D _{5m}	f ₁	l ₁	l ₃	l ₄	a _r	DCINN*				
C4	C4-CGHR -15075-1902	18,0	40	14,5	75	53,0	31	5,5	20	0,4	2	LC..1902..	
	C4-CGHL -15075-1902	18,0	40	14,5	75	53,0	31	5,5	20	0,4	2	LC..1902..	
C5	C5-CGHR -15075-1902	18,0	50	14,5	75	53,0	31	5,5	20	0,5	2	LC..1902..	
	C5-CGHL -15075-1902	18,0	50	14,5	75	53,0	31	5,5	20	0,5	2	LC..1902..	
C6	C6-CGHR -15075-1902	18,0	60	14,5	75	51,0	31	5,5	20	0,9	2	LC..1902..	
	C6-CGHL -15075-1902	18,0	60	14,5	75	51,0	31	5,5	20	0,9	2	LC..1902..	
C4	C4-CGJR -19080-1902	23,0	40	19,0	80	58,0	31	7,5	25	0,4	2	LC..1902..	
	C4-CGJL -19080-1902	23,0	40	19,0	80	58,0	31	7,5	25	0,4	2	LC..1902..	
C5	C5-CGJR -19080-1902	23,0	50	19,0	80	58,0	31	7,5	25	0,6	2	LC..1902..	
	C5-CGJL -19080-1902	23,0	50	19,0	80	58,0	31	7,5	25	0,6	2	LC..1902..	
C6	C6-CGJR -19080-1902	23,0	60	19,0	80	56,0	31	7,5	25	0,9	2	LC..1902..	
	C6-CGJL -19080-1902	23,0	60	19,0	80	56,0	31	7,5	25	0,9	2	LC..1902..	

*DCINN – minimum bore diameter, see page(s) 477

Spare Parts, Parts included in delivery

For holder	Clamp key	Clamp screw	Torque value Nm
CG.R/L...-1902	T15P-7	L85011-T15P	5,0

Please check availability in current price and stock-list

Toolholders for inserts LCGA, LCGF, LCGN, LCMF and LCMR



• For insert programme, see page(s) 573-576, 592

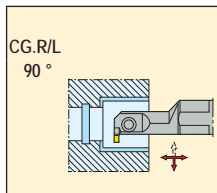
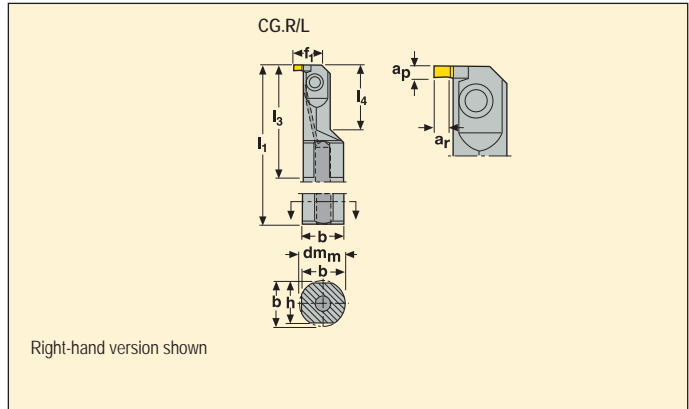

	Part No.	Dimensions in mm										KG	Seat size	
		dm _m	h	b	l ₁	l ₃	l ₄	f ₁	a _r	DCINN*				
3	A16Q-CGER1303	16	15	15,5	180	40,0	25	10,2	3,0	16	0,3	3	LC..1303..	
	A16Q-CGEL1303	16	15	15,5	180	40,0	25	10,2	3,0	16	0,3	3	LC..1303..	
3	A20R-CGFR1303	20	18	19,0	200	52,0	30	14,5	5,5	20	0,4	3	LC..1303..	
	A20R-CGFL1303	20	18	19,0	200	52,0	30	14,5	5,5	20	0,4	3	LC..1303..	
3	A25S-CGHR1303	25	23	24,0	250	64,0	40	19,0	7,5	25	0,8	3	LC..1303..	
	A25S-CGHL1303	25	23	24,0	250	64,0	40	19,0	7,5	25	0,8	3	LC..1303..	
3	A32T-CGJR1303	32	30	31,0	300	77,0	50	25,5	10,5	32	1,6	3	LC..1303..	
	A32T-CGJL1303	32	30	31,0	300	77,0	50	25,5	10,5	32	1,6	3	LC..1303..	
4	A20R-CGFR1304	20	18	19,0	200	52,0	30	14,5	5,5	20	0,4	4	LC..1304..	
	A20R-CGFL1304	20	18	19,0	200	52,0	30	14,5	5,5	20	0,4	4	LC..1304..	
4	A25S-CGFR1304	25	23	24,0	250	64,0	40	19,0	7,5	25	0,8	4	LC..1304..	
	A25S-CGFL1304	25	23	24,0	250	64,0	40	19,0	7,5	25	0,8	4	LC..1304..	
4	A32T-CGHR1304	32	30	31,0	300	77,0	50	25,5	10,5	32	1,6	4	LC..1304..	
	A32T-CGHL1304	32	30	31,0	300	77,0	50	25,5	10,5	32	1,6	4	LC..1304..	

*DCINN – minimum bore diameter, see page(s) 477

Spare Parts, Parts included in delivery

For holder	Clamp key	Clamp screw	Torque value Nm
A16Q-..	T15P-7	L85011-T15P	5,0
A20R-..	T15P-7	L85011-T15P	5,0
A25S-..	T15P-7	L85011-T15P	5,0
A32T-..	T15P-7	L85011-T15P	5,0

Accessories, to be ordered separately

For holder	Coolant adapter
A16Q-..	SEAL16
A20R-..	SEAL20
A25S-..	SEAL25
A32T-..	SEAL32

Please check availability in current price and stock-list

Toolholders for inserts LCGF, LCGN, LCMF and LCMR



• For insert programme, see page(s) 578-591, 593-594

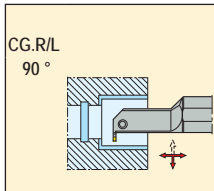
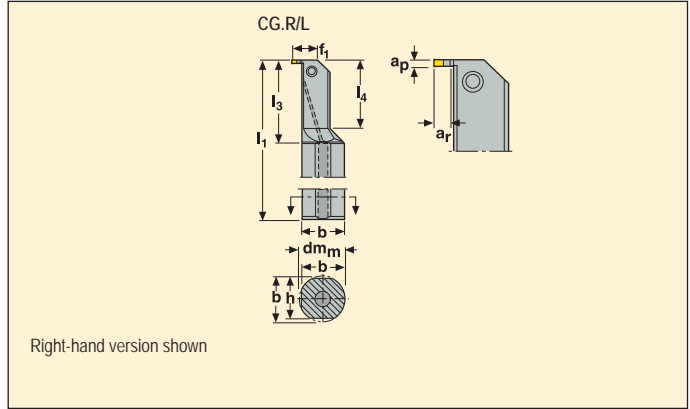

	Part No.	Dimensions in mm										KG	Seat size	
		dm _m	h	b	l ₁	l ₃	l ₄	f ₁	a _r	DCINN*				
3	A32T-CGIR1603	32	30	31,0	300	60,0	50	24,0	9,0	32	1,6	3	LC..1603..	
	A32T-CGIL1603	32	30	31,0	300	60,0	50	24,0	9,0	32	1,6	3	LC..1603..	
4	A32T-CGGR1604	32	30	31,0	300	60,0	50	24,0	9,0	32	1,6	4	LC..1604..	
	A32T-CGGL1604	32	30	31,0	300	60,0	50	24,0	9,0	32	1,6	4	LC..1604..	
5	A32T-CGFR1605	32	30	31,0	300	60,0	50	24,0	9,0	32	1,6	5	LC..1605..	
	A32T-CGFL1605	32	30	31,0	300	60,0	50	24,0	9,0	32	1,6	5	LC..1605..	
6	A32T-CGFR1606	32	30	31,0	300	60,0	50	24,0	9,0	32	1,6	6	LC..1606..	
	A32T-CGFL1606	32	30	31,0	300	60,0	50	24,0	9,0	32	1,6	6	LC..1606..	

*DCINN – minimum bore diameter, see page(s) 477

Spare Parts, Parts included in delivery

Accessories, to be ordered separately

For holder	Clamp key	Clamp screw	Torque value Nm	For holder	Coolant adapter
CG.R/L..03	T15P-7	L85011-T15P	5,0	CG.R/L..03	SEAL32
CG.R/L..04	T15P-7	L85011-T15P	5,0	CG.R/L..04	SEAL32
CG.R/L..05	T20P-7	L86015-T20P	6,0	CG.R/L..05	SEAL32
CG.R/L..06	T20P-7	L86015-T20P	6,0	CG.R/L..06	SEAL32

Please check availability in current price and stock-list

Toolholders for inserts LCGF, LCGN, LCMF and LCMR



- For insert programme, see page(s) 578-591, 593-594

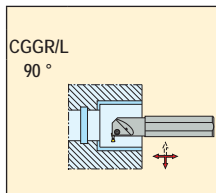
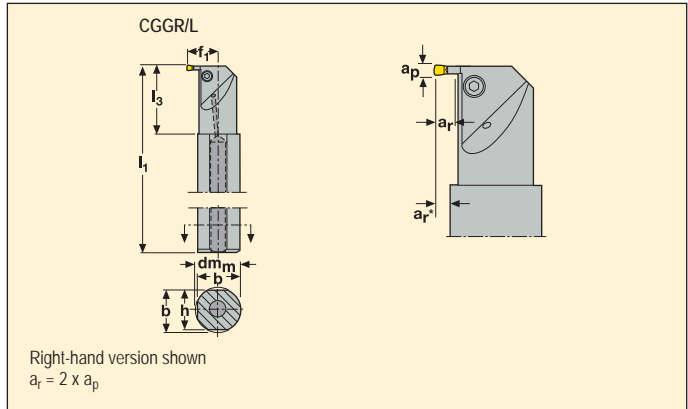

	Part No.	Dimensions in mm										KG	Seat size	
		dm _m	h	b	l ₁	l ₃	f ₁	a _r	a _r **	DCINN*				
3	A40T-CGGR03	40	37	38,5	300	60,0	26,0	5,5	5,5	45	2,5	3	LC..1603..	
	A40T-CGGL03	40	37	38,5	300	60,0	26,0	5,5	5,5	45	2,5	3	LC..1603..	
4	A40T-CGGR04	40	37	38,5	300	60,0	27,0	6,5	6,5	45	2,4	4	LC..1604..	
	A40T-CGGL04	40	37	38,5	300	60,0	27,0	6,5	6,5	45	2,4	4	LC..1604..	
5	A40T-CGGR05	40	37	38,5	300	60,0	28,0	7,5	7,5	45	2,4	5	LC..1605..	
	A40T-CGGL05	40	37	38,5	300	60,0	28,0	7,5	7,5	45	2,4	5	LC..1605..	
6	A40T-CGGR06	40	37	38,5	300	60,0	29,0	8,5	8,5	45	2,4	6	LC..1606..	
	A40T-CGGL06	40	37	38,5	300	60,0	29,0	8,5	8,5	45	2,4	6	LC..1606..	

*DCINN – minimum bore diameter, see page(s) 477

**If toolholder enters bore more than l₃

Spare Parts, Parts included in delivery

For holder	Clamp key	Clamp screw	Torque value Nm
-.03	3SMS795	MC6S4X14	3,5
-.04	4SMS795	MC6S5X14	5,0
-.05	4SMS795	MC6S5X14	5,0
-.06	5SMS795	TCEI0614	8,0

Accessories, to be ordered separately

For holder	Coolant adapter
-.03	SEAL40
-.04	SEAL40
-.05	SEAL40
-.06	SEAL40



Please check availability in current price and stock-list

Toolholders for inserts LCGN, LCMF and LCMR



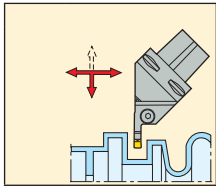
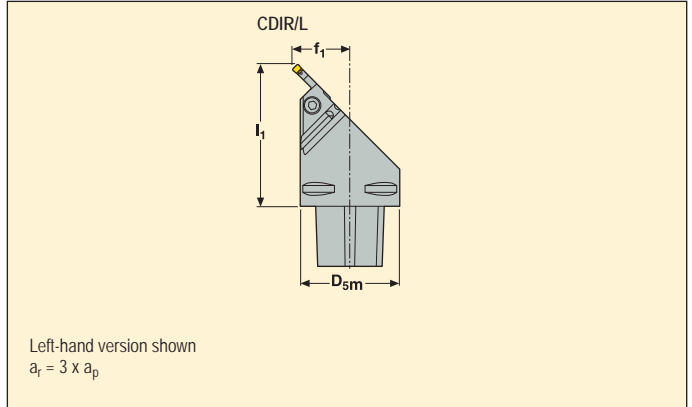

- For insert programme, see page(s) 578-591, 593-594



	Part No.	Dimensions in mm				 KG	Seat size	
		D_{sm}	f_1	l_1	a_r			
3	C6-CDIR-33090-03JET	63	33	90	9	1,5	3	LC..1603..
	C6-CDIL-33090-03JET	63	33	90	9	1,5	3	LC..1603..
4	C6-CDIR-33090-04JET	63	33	90	12	1,5	4	LC..1604..
	C6-CDIL-33090-04JET	63	33	90	12	1,5	4	LC..1604..
5	C6-CDIR-33090-05JET	63	33	90	15	1,5	5	LC..1605..
	C6-CDIL-33090-05JET	63	33	90	15	1,5	5	LC..1605..
6	C6-CDIR-33090-06JET	63	33	90	18	1,5	6	LC..1606..
	C6-CDIL-33090-06JET	63	33	90	18	1,5	6	LC..1606..
8	C6-CDIR-33090-08JET	63	33	90	24	1,5	8	LC..3008..
	C6-CDIL-33090-08JET	63	33	90	24	1,5	8	LC..3008..

Spare Parts, Parts included in delivery

For holder	Clamp key	Clamp screw	Torque value Nm
			
CDIR/L...-03	4SMS795	TCEI0513	6,0
CDIR/L...-04	5SMS795	TCEI0613	8,0
CDIR/L...-05	5SMS795	TCEI0613	8,0
CDIR/L...-06	6SMS795	TCEI0815	10,0
CDIR/L...-08	6SMS795	TCEI1020	15,0

Please check availability in current price and stock-list

Toolholders



- For blades programme, see page(s) 565-569
- How to assemble, see page(s) 474-476

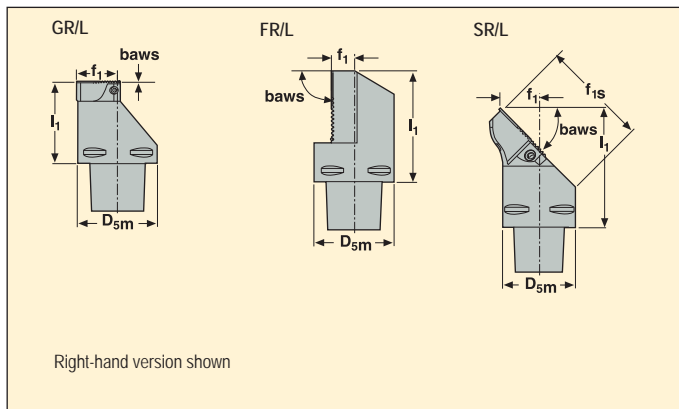

GR/L	Capto size	Part No.	Dimensions in mm				baws°	KG
			D _{5m}	f ₁	f _{1s}	l ₁		
	C4	C4-GR-21050-V21	40	21,0	–	50	0	0,5
		C4-GL-21050-V21	40	21,0	–	50	0	0,5
	C5	C5-GR-29060-V21	50	26,0	–	60	0	0,9
		C5-GL-29060-V21	50	26,0	–	60	0	1,0
FR/L	C6	C6-GR-39065-V21	63	39,0	–	65	0	1,4
		C6-GL-39065-V21	63	39,0	–	65	0	1,4
	C4	C4-FR-11055-V21	40	11,1	–	55	90	0,5
		C4-FL-11055-V21	40	11,1	–	55	90	0,5
SR/L	C5	C5-FR-16060-V21	50	16,1	–	60	90	0,9
		C5-FL-16060-V21	50	16,1	–	60	90	0,9
	C6	C6-FR-23065-V21	63	22,6	–	65	90	1,6
		C6-FL-23065-V21	63	22,6	–	65	90	1,6
	C4	C4-SR-21065-V21	40	21,0	59,3	65	45	0,5
		C4-SL-21065-V21	40	21,0	59,3	65	45	0,5
	C5	C5-SR-26075-V21	50	26,0	73,4	75	45	0,9
		C5-SL-26075-V21	50	26,0	73,4	75	45	0,9
	C6	C6-SR-33085-V21	63	33,0	92,5	85	45	1,5
		C6-SL-33085-V21	63	33,0	92,5	85	45	1,5

Spare Parts, Parts included in delivery

For holder	Key	Locking screw	Screw	Torque value Nm
...V21	T20P-7L	F85015-T20P	C46017-T20P	6,0

Please check availability in current price and stock-list

Toolholders

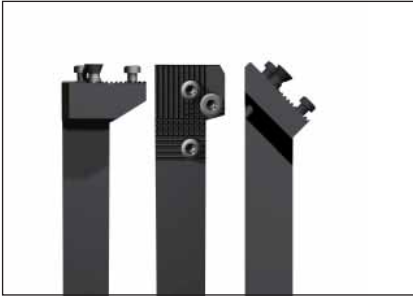

- For blades programme, see page(s) 565-569
- How to assemble, see page(s) 474-476

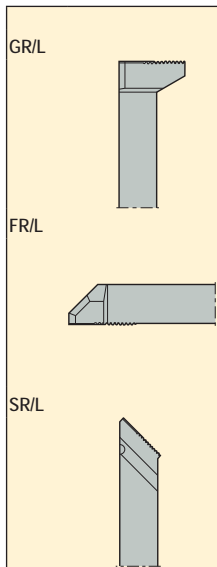
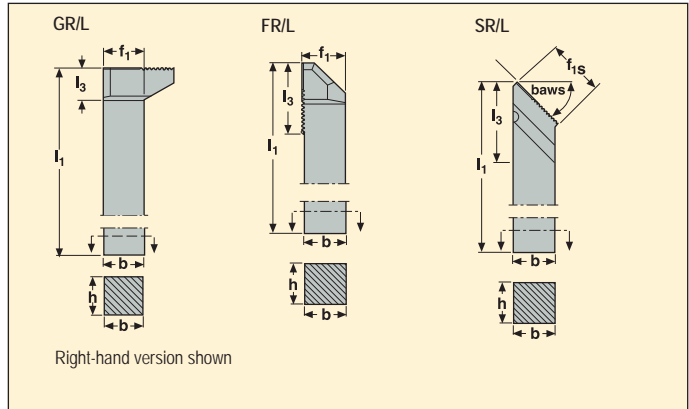

Part No.	Dimensions in mm						baws°	KG
	h	b	l ₁	f ₁	f _{1s}	l ₃		
GR2020K-V21	20	20	125	19,9	–	16,0	0	0,5
GL2020K-V21	20	20	125	19,9	–	16,0	0	0,5
GR2525M-V21	25	25	150	24,9	–	16,0	0	0,8
GL2525M-V21	25	25	150	24,9	–	16,0	0	0,8
GR3225P-V21	32	25	170	24,9	–	16,0	0	1,2
GL3225P-V21	32	25	170	24,9	–	16,0	0	1,2
FR2020K-V21	20	20	125	20,8	–	33,6	90	0,5
FL2020K-V21	20	20	125	20,8	–	33,6	90	0,4
FR2525M-V21	25	25	150	25,8	–	33,6	90	0,8
FL2525M-V21	25	25	150	25,8	–	33,6	90	0,8
FR3225P-V21	32	25	170	25,8	–	33,6	90	1,1
FL3225P-V21	32	25	170	25,8	–	33,6	90	1,1
SR2020K-V21	20	20	125	–	34,6	43,5	45	0,4
SL2020K-V21	20	20	125	–	34,6	43,5	45	0,4
SR2525M-V21	25	25	150	–	34,6	47,5	45	0,8
SL2525M-V21	25	25	150	–	34,6	47,5	45	0,8
SR3225P-V21	32	25	170	–	34,6	47,5	45	1,1
SL3225P-V21	32	25	170	–	34,6	47,5	45	1,1

Spare Parts, Parts included in delivery

For holder	Key	Locking screw	Screw	Torque value Nm
..V21	T20P-7L	F85015-T20P	C46017-T20P	6,0

Please check availability in current price and stock-list

Toolholders



- For blades programme, see page(s) 565-569
- How to assemble, see page(s) 474-475

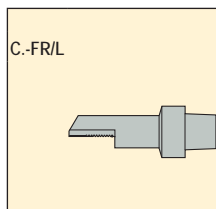
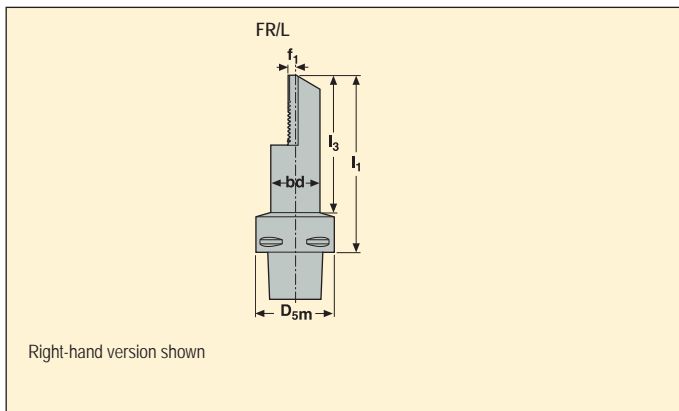

Capto size	Part No.	Dimensions in mm					KG
		bd	D _{5m}	f ₁	l ₁	l ₃	
C4	C4-FR-04090-V21	25	40	3,5	90	70	0,5
	C4-FL-04090-V21	25	40	3,5	90	70	0,5
	C4-FR-07110-V21	32	40	7,0	110	90	0,8
	C4-FL-07110-V21	32	40	7,0	110	90	0,7
	C4-FR-11140-V21	40	40	11,0	140	120	1,3
	C4-FL-11140-V21	40	40	11,0	140	120	1,3
C5	C5-FR-04090-V21	25	50	3,5	90	70	0,6
	C5-FL-04090-V21	25	50	3,5	90	70	0,7
	C5-FR-07110-V21	32	50	7,0	110	90	0,9
	C5-FL-07110-V21	32	50	7,0	110	90	0,9
	C5-FR-11140-V21	40	50	11,0	140	120	1,5
	C5-FL-11140-V21	40	50	11,0	140	120	1,6
C6	C6-FR-04090-V21	25	63	3,5	90	68	1,0
	C6-FL-04090-V21	25	63	3,5	90	68	0,9
	C6-FR-07110-V21	32	63	7,0	110	88	1,2
	C6-FL-07110-V21	32	63	7,0	110	88	1,5
	C6-FR-11140-V21	40	63	11,0	140	118	1,8
	C6-FL-11140-V21	40	63	11,0	140	118	1,8

Spare Parts, Parts included in delivery

For holder	Key	Locking screw	Screw	Torque value Nm
...				
...V21	T20P-7L	F85015-T20P	C46017-T20P	6,0

Please check availability in current price and stock-list

Toolholders



- For blades programme, see page(s) 565-569
- How to assemble, see page(s) 474-475

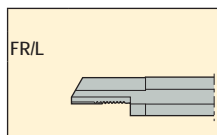
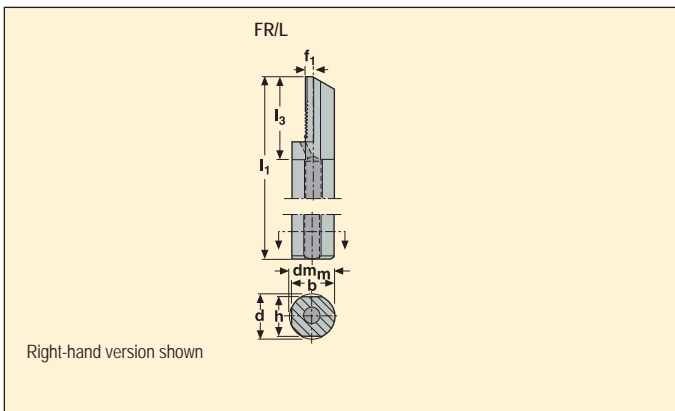

Part No.	Dimensions in mm						 KG
	dm _m	h	b	l ₁	f ₁	l ₃	
A25R-FR-V21	25	23	24,0	200	4,1	45	0,6
A25R-FL-V21	25	23	24,0	200	4,1	45	0,7
A32S-FR-V21	32	30	31,0	250	7,6	45	1,4
A32S-FL-V21	32	30	31,0	250	7,6	45	1,4
A40T-FR-V21	40	37	38,5	300	11,6	45	2,6
A40T-FL-V21	40	37	38,5	300	11,6	45	2,6

Spare Parts, Parts included in delivery

Accessories, to be ordered separately

For holder	Key	Locking screw	Screw	Torque value Nm
A25R-	T20P-7L	F85015-T20P	C46017-T20P	6,0
A32S-	T20P-7L	F85015-T20P	C46017-T20P	6,0
A40T-	T20P-7L	F85015-T20P	C46017-T20P	6,0

For holder	Coolant adapter
A25R-	SEAL25
A32S-	SEAL32
A40T-	SEAL40

Please check availability in current price and stock-list

Blades for inserts LCGF, LCGN, LCMF and LCMR



- For holders programme, see page(s) 561-564
- For inserts programme, see page(s) 573-576, 578-594

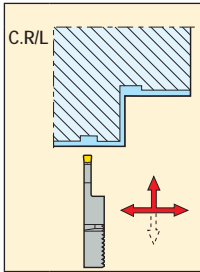
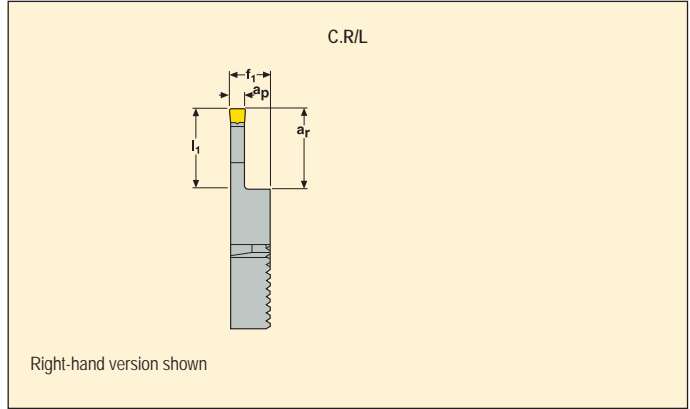

C.R/L	Part No.	Dimensions in mm			KG	Icon
		l ₁	f ₁	a _r **		
3	V21 -CIR1303	10,2	9,2	9	0,1	LC..1303..
	-CIL1303	10,2	9,2	9	0,1	LC..1303..
	-CMR1303	16,2	9,2	15	0,1	LC..1303..
	-CML1303	16,2	9,2	15	0,1	LC..1303..
4	V21 -CIR1304	13,2	9,2	12	0,1	LC..1304..
	-CIL1304	13,2	9,2	12	0,1	LC..1304..
	-CMR1304	21,2	9,2	20	0,1	LC..1304..
	-CML1304	21,2	9,2	20	0,1	LC..1304..
3	V21 -CMR1603	16,2	9,2	15	0,1	LC..1603..
	-CML1603	16,2	9,2	15	0,1	LC..1603..
4	V21 -CMR1604	21,2	9,2	20	0,1	LC..1604..
	-CML1604	21,2	9,2	20	0,1	LC..1604..
5	V21 -CIR1605	16,2	9,2	15	0,1	LC..1605..
	-CIL1605	16,2	9,2	15	0,1	LC..1605..
	-CMR1605	26,2	9,2	25	0,1	LC..1605..
	-CML1605	26,2	9,2	25	0,1	LC..1605..
6	V21 -CIR1606	19,2	9,2	18	0,1	LC..1606..
	-CIL1606	19,2	9,2	18	0,1	LC..1606..
	-CMR1606	31,2	9,2	30	0,1	LC..1606..
	-CML1606	31,2	9,2	30	0,1	LC..1606..

Please check availability in current price and stock-list

**Max depth of cut for LCGF/LCMF13.. = 11 mm, LCGF/LCMF16.. = 14 mm

Blades for inserts LCGF, LCGN, LCMF and LCMR



- For holders programme, see page(s) 561-564
- For inserts programme, see page(s) 573-576, 592

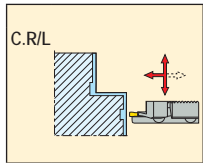
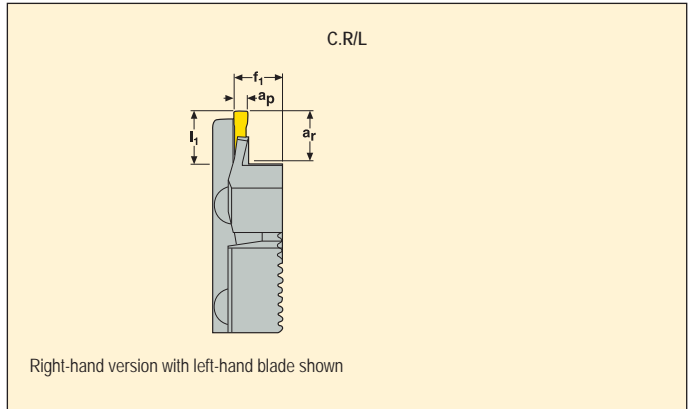

3	Part No.	Dimensions in mm					KG	Image
		INPLM	INPLX	l ₁	f ₁	a _r **		
V21-CJR	1303L030017	17	30	11,7	9,2	10,5	0,1	LC..1303..
	1303L039024	24	39	11,7	9,2	10,5	0,1	LC..1303..
V21-CKR	1303L050033	33	50	13,2	9,2	12,0	0,1	LC..1303..
	1303L060043	43	60	13,2	9,2	12,0	0,1	LC..1303..
1303L076053	1303L076053	53	76	13,2	9,2	12,0	0,1	LC..1303..
	1303L076053	53	76	19,2	9,2	18,0	0,1	LC..1303..
V21-COR	1303L030017	17	30	19,2	9,2	18,0	0,1	LC..1303..
	1303L039024	24	39	19,2	9,2	18,0	0,1	LC..1303..
1303L050033	1303L050033	33	50	19,2	9,2	18,0	0,1	LC..1303..
	1303L060043	43	60	19,2	9,2	18,0	0,1	LC..1303..
1303L076053	1303L076053	53	76	19,2	9,2	18,0	0,1	LC..1303..
	1303L100070	70	100	19,2	9,2	18,0	0,1	LC..1303..
1303L136094	1303L136094	94	136	19,2	9,2	18,0	0,1	LC..1303..
	1303L200130	130	200	19,2	9,2	18,0	0,1	LC..1303..
V21-CJL	1303R030017	17	30	11,7	9,2	10,5	0,1	LC..1303..
	1303R039024	24	39	11,7	9,2	10,5	0,1	LC..1303..
V21-CKL	1303R050033	33	50	13,2	9,2	12,0	0,1	LC..1303..
	1303R060043	43	60	13,2	9,2	12,0	0,1	LC..1303..
1303R076053	1303R076053	53	76	13,2	9,2	12,0	0,1	LC..1303..
	1303R076053	53	76	19,2	9,2	18,0	0,1	LC..1303..
V21-COL	1303R030017	17	30	19,2	9,2	18,0	0,1	LC..1303..
	1303R039024	24	39	19,2	9,2	18,0	0,1	LC..1303..
1303R050033	1303R050033	33	50	19,2	9,2	18,0	0,1	LC..1303..
	1303R060043	43	60	19,2	9,2	18,0	0,1	LC..1303..
1303R076053	1303R076053	53	76	19,2	9,2	18,0	0,1	LC..1303..
	1303R100070	70	100	19,2	9,2	18,0	0,1	LC..1303..
1303R136094	1303R136094	94	136	19,2	9,2	18,0	0,1	LC..1303..
	1303R200130	130	200	19,2	9,2	18,0	0,1	LC..1303..

Please check availability in current price and stock-list

Initial plunge (INPLM/INPLX) relates to face groove diameter, see page(s) 477.

**Max depth of cut for LCGF/LCMF13.. = 11 mm

Blades for inserts LCGF, LCGN, LCMF and LCMR



- For holders programme, see page(s) 561-564
- For inserts programme, see page(s) 573-576, 592

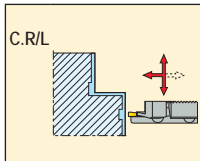
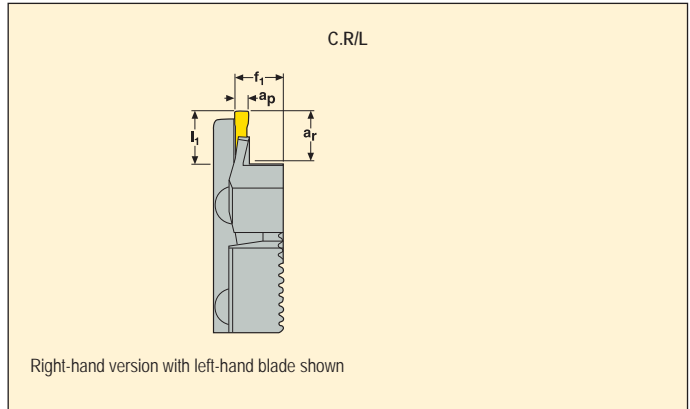

4	Part No.	Dimensions in mm						KG	
		INPLM	INPLX	l ₁	f ₁	a _r **			
V21-CHR	1304L030017	17	30	11,2	9,2	10,0	0,1	LC..1304..	
	1304L034021	21	34	11,2	9,2	10,0	0,1	LC..1304..	
V21-CIR	1304L040026	26	40	13,2	9,2	12,0	0,1	LC..1304..	
	1304L050032	32	50	13,2	9,2	12,0	0,1	LC..1304..	
	1304L060042	42	60	13,2	9,2	12,0	0,1	LC..1304..	
	1304L075052	52	75	13,2	9,2	12,0	0,1	LC..1304..	
	1304L100067	67	100	13,2	9,2	12,0	0,1	LC..1304..	
V21-CMR	1304L030017	17	30	21,2	9,2	20,0	0,1	LC..1304..	
	1304L034021	21	34	21,2	9,2	20,0	0,1	LC..1304..	
	1304L040026	26	40	21,2	9,2	20,0	0,1	LC..1304..	
	1304L050032	32	50	21,2	9,2	20,0	0,1	LC..1304..	
	1304L060042	42	60	21,2	9,2	20,0	0,1	LC..1304..	
	1304L075052	52	75	21,2	9,2	20,0	0,1	LC..1304..	
	1304L100067	67	100	21,2	9,2	20,0	0,1	LC..1304..	
	1304L135092	92	135	21,2	9,2	20,0	0,1	LC..1304..	
	1304L200127	127	200	21,2	9,2	20,0	0,1	LC..1304..	
V21-CHL	1304R030017	17	30	11,2	9,2	10,0	0,1	LC..1304..	
	1304R034021	21	34	11,2	9,2	10,0	0,1	LC..1304..	
V21-CIL	1304R040026	26	40	13,2	9,2	12,0	0,1	LC..1304..	
	1304R050032	32	50	13,2	9,2	12,0	0,1	LC..1304..	
	1304R060042	42	60	13,2	9,2	12,0	0,1	LC..1304..	
	1304R075052	52	75	13,2	9,2	12,0	0,1	LC..1304..	
	1304R100067	67	100	13,2	9,2	12,0	0,1	LC..1304..	
V21-CML	1304R030017	17	30	21,2	9,2	20,0	0,1	LC..1304..	
	1304R034021	21	34	21,2	9,2	20,0	0,1	LC..1304..	
	1304R040026	26	40	21,2	9,2	20,0	0,1	LC..1304..	
	1304R050032	32	50	21,2	9,2	20,0	0,1	LC..1304..	
	1304R060042	42	60	21,2	9,2	20,0	0,1	LC..1304..	
	1304R075052	52	75	21,2	9,2	20,0	0,1	LC..1304..	
	1304R100067	67	100	21,2	9,2	20,0	0,1	LC..1304..	
	1304R135092	92	135	21,2	9,2	20,0	0,1	LC..1304..	
	1304R200127	127	200	21,2	9,2	20,0	0,1	LC..1304..	

Please check availability in current price and stock-list

Initial plunge (INPLM/INPLX) relates to face groove diameter, see page(s) 477.





**Max depth of cut for LCGF/LCMF13.. = 11 mm

Blades for inserts LCGF, LCGN, LCMF and LCMR

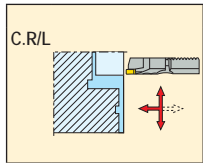
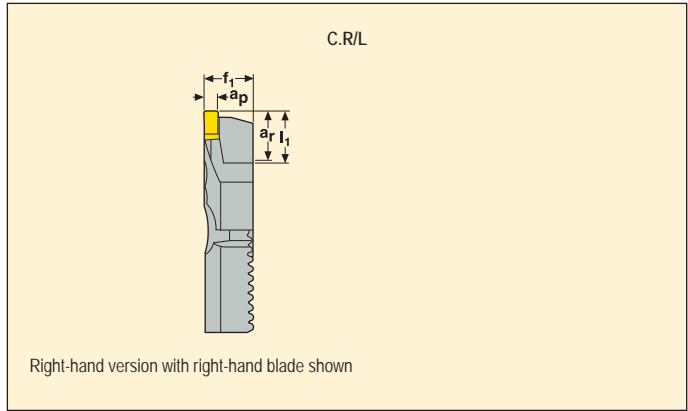

- For holders programme, see page(s) 561-564
- For inserts programme, see page(s) 573-576, 592



		Part No.	Dimensions in mm					 KG	
			INPLM	INPLX	l ₁	f ₁	a _r **		
3		V21-CJR 1303R030017	17	30	11,7	9,2	10,5	0,1	LC..1303..
		1303R039024	24	39	11,7	9,2	10,5	0,1	LC..1303..
		V21-CKR 1303R050033	33	50	13,2	9,2	12,0	0,1	LC..1303..
		1303R060043	43	60	13,2	9,2	12,0	0,1	LC..1303..
		1303R076053	53	76	13,2	9,2	12,0	0,1	LC..1303..
		V21-COR 1303R030017	17	30	19,2	9,2	18,0	0,1	LC..1303..
		1303R039024	24	39	19,2	9,2	18,0	0,1	LC..1303..
		1303R050033	33	50	19,2	9,2	18,0	0,1	LC..1303..
		1303R060043	43	60	19,2	9,2	18,0	0,1	LC..1303..
		1303R076053	53	76	19,2	9,2	18,0	0,1	LC..1303..
		1303R100070	70	100	19,2	9,2	18,0	0,1	LC..1303..
		1303R136094	94	136	19,2	9,2	18,0	0,1	LC..1303..
		1303R200130	130	200	19,2	9,2	18,0	0,1	LC..1303..
		V21-CJL 1303L030017	17	30	11,7	9,2	10,5	0,1	LC..1303..
		1303L039024	24	39	11,7	9,2	10,5	0,1	LC..1303..
		V21-CKL 1303L050033	33	50	13,2	9,2	12,0	0,1	LC..1303..
		1303L060043	43	60	13,2	9,2	12,0	0,1	LC..1303..
		1303L076053	53	76	13,2	9,2	12,0	0,1	LC..1303..
		V21-COL 1303L030017	17	30	19,2	9,2	18,0	0,1	LC..1303..
		1303L039024	24	39	19,2	9,2	18,0	0,1	LC..1303..
		1303L050033	33	50	19,2	9,2	18,0	0,1	LC..1303..
		1303L060043	43	60	19,2	9,2	18,0	0,1	LC..1303..
		1303L076053	53	76	19,2	9,2	18,0	0,1	LC..1303..
		1303L100070	70	100	19,2	9,2	18,0	0,1	LC..1303..
1303L136094	94	136	19,2	9,2	18,0	0,1	LC..1303..		
1303L200130	130	200	19,2	9,2	18,0	0,1	LC..1303..		

Please check availability in current price and stock-list

Initial plunge (INPLM/INPLX) relates to face groove diameter, see page(s) 477.
 **Max depth of cut for LCGF/LCMF13.. = 11 mm

Blades for inserts LCGF, LCGN, LCMF and LCMR



- For holders programme, see page(s) 561-564
- For inserts programme, see page(s) 573-576, 592

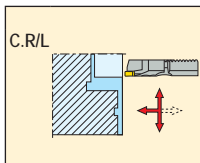
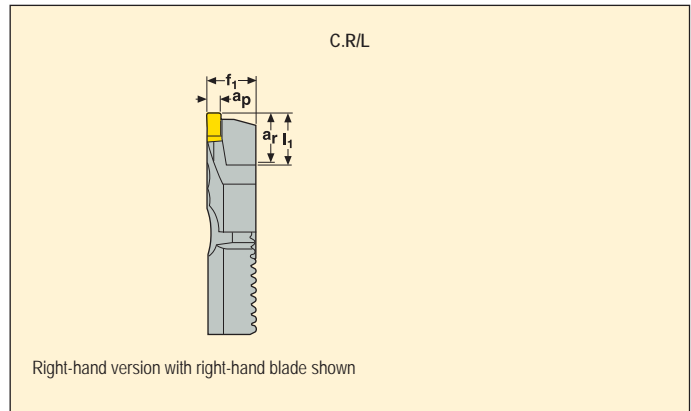

4	Part No.	Dimensions in mm						KG	
		INPLM	INPLX	I ₁	f ₁	a _r **			
V21-CHR	1304R030017	17	30	11,2	9,2	10,0	0,1	LC..1304..	
	1304R034021	21	34	11,2	9,2	10,0	0,1	LC..1304..	
	V21-CIR	1304R040026	26	40	13,2	9,2	12,0	0,1	LC..1304..
		1304R050032	32	50	13,2	9,2	12,0	0,1	LC..1304..
	1304R060042	42	60	13,2	9,2	12,0	0,1	LC..1304..	
	1304R075052	52	75	13,2	9,2	12,0	0,1	LC..1304..	
	1304R100067	67	100	13,2	9,2	12,0	0,1	LC..1304..	
	V21-CMR	1304R030017	17	30	21,2	9,2	20,0	0,1	LC..1304..
		1304R034021	21	34	21,2	9,2	20,0	0,1	LC..1304..
		1304R040026	26	40	21,2	9,2	20,0	0,1	LC..1304..
		1304R050032	32	50	21,2	9,2	20,0	0,1	LC..1304..
		1304R060042	42	60	21,2	9,2	20,0	0,1	LC..1304..
		1304R075052	52	75	21,2	9,2	20,0	0,1	LC..1304..
		1304R100067	67	100	21,2	9,2	20,0	0,1	LC..1304..
		1304R135092	92	135	21,2	9,2	20,0	0,1	LC..1304..
	1304R200127	127	200	21,2	9,2	20,0	0,1	LC..1304..	
	V21-CHL	1304L030017	17	30	11,2	9,2	10,0	0,1	LC..1304..
		1304L034021	21	34	11,2	9,2	10,0	0,1	LC..1304..
	V21-CIL	1304L040026	26	40	13,2	9,2	12,0	0,1	LC..1304..
		1304L050032	32	50	13,2	9,2	12,0	0,1	LC..1304..
1304L060042	42	60	13,2	9,2	12,0	0,1	LC..1304..		
1304L075052	52	75	13,2	9,2	12,0	0,1	LC..1304..		
1304L100067	67	100	13,2	9,2	12,0	0,1	LC..1304..		
V21-CML	1304L030017	17	30	21,2	9,2	20,0	0,1	LC..1304..	
	1304L034021	21	34	21,2	9,2	20,0	0,1	LC..1304..	
	1304L040026	26	40	21,2	9,2	20,0	0,1	LC..1304..	
	1304L050032	32	50	21,2	9,2	20,0	0,1	LC..1304..	
	1304L060042	42	60	21,2	9,2	20,0	0,1	LC..1304..	
	1304L075052	52	75	21,2	9,2	20,0	0,1	LC..1304..	
	1304L100067	67	100	21,2	9,2	20,0	0,1	LC..1304..	
	1304L135092	92	135	21,2	9,2	20,0	0,1	LC..1304..	
	1304L200127	127	200	21,2	9,2	20,0	0,1	LC..1304..	

Please check availability in current price and stock-list

Initial plunge (INPLM/INPLX) relates to face groove diameter, see page(s) 477.

**Max depth of cut for LCGF/LCMF13.. = 11 mm

Toolholders for inserts LCGF, LCGN, LCMF and LCMR



- Blades up to D = 65
- For insert programme, see page(s) 577-591, 593-594

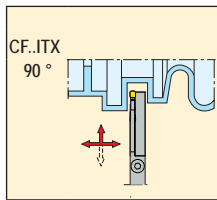
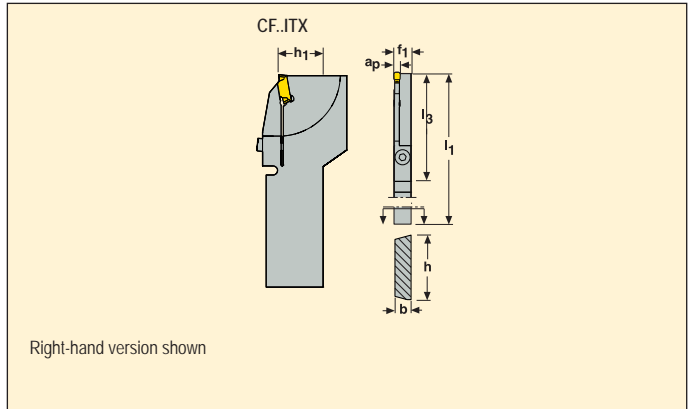

	Part No.	Dimensions in mm							KG	
		h	b	l ₁	f ₁	l ₃	h ₁	D _m *		
2,0	CFTR26ITX1902RRB	26	7,85	110,0	8	44,0	20,9	34,0	0,2	LCMF1902..
	CFZR26ITX2802RRB	26	7,85	119,5	8	52,0	20,9	54,0	0,2	LCMF2802..
	CFTR32ITX1902RRB	32	7,85	110,0	8	43,0	24,5	34,0	0,2	LCMF1902..
3,0	CFZR32ITX2802RRB	32	7,85	119,5	8	52,5	24,5	54,0	0,2	LCMF2802..
	CFXR32ITX1603RRB	32	7,85	117,5	8	50,5	24,5	65,0	0,3	LCMR1603..
2,0	CFTR26ITX1902LRB	26	7,85	110,0	8	44,0	20,9	34,0	0,2	LCMF1902..
	CFZR26ITX2802LRB	26	7,85	119,5	8	52,0	20,9	54,0	0,2	LCMF2802..
	CFTR32ITX1902LRB	32	7,85	110,0	8	43,0	24,5	34,0	0,2	LCMF1902..
	CFZR32ITX2802LRB	32	7,85	119,5	8	52,5	24,5	54,0	0,2	LCMF2802..
3,0	CFXR32ITX1603LRB	32	7,85	117,5	8	50,5	24,5	65,0	0,3	LCMR1603..
2,0	CFTL26ITX1902RRB	26	7,85	110,0	8	44,0	20,9	34,0	0,2	LCMF1902..
	CFZL26ITX2802RRB	26	7,85	119,5	8	52,0	20,9	54,0	0,2	LCMF2802..
	CFTL32ITX1902RRB	32	7,85	110,0	8	43,0	24,5	34,0	0,2	LCMF1902..
	CFZL32ITX2802RRB	32	7,85	119,5	8	52,5	24,5	54,0	0,2	LCMF2802..
3,0	CFXL32ITX1603RRB	32	7,85	117,5	8	50,5	24,5	65,0	0,3	LCMR1603..
2,0	CFTL26ITX1902LRB	26	7,85	110,0	8	44,0	20,9	34,0	0,2	LCMF1902..
	CFZL26ITX2802LRB	26	7,85	119,5	8	52,0	20,9	54,0	0,2	LCMF2802..
	CFTL32ITX1902LRB	32	7,85	110,0	8	43,0	24,5	34,0	0,2	LCMF1902..
	CFZL32ITX2802LRB	32	7,85	119,5	8	52,5	24,5	54,0	0,3	LCMF2802..
3,0	CFXL32ITX1603LRB	32	7,85	117,5	8	50,5	24,5	65,0	0,3	LCMR1603..

*Due to the design, grooving depth is limited, see page(s) 477.

Spare Parts, Parts included in delivery

For size	Clamp key	Clamp screw
26-32	3SMS795	TCEI0416

Front view

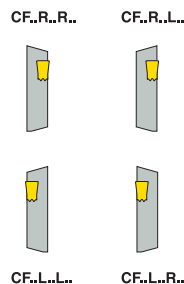

Please check availability in current price and stock-list

Toolholder and blades for inserts LCGN, LCMF and LCMR



• For insert programme, see page(s) 578-591, 593-594

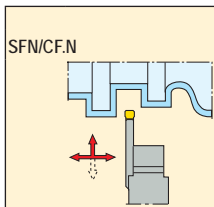
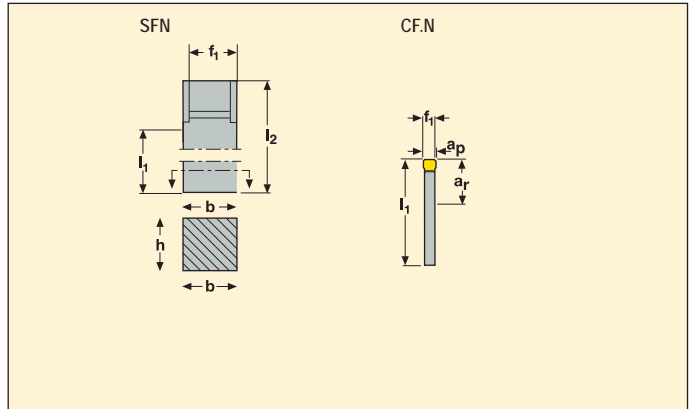

	Part No.	Dimensions in mm						KG	Seat size	
		h	b	l ₁	l ₂	f ₁	a _r *			
	SFN2525N	25	25	101,2	134	21,7	–	0,7	–	–
3	CFLN-03	–	–	46,4	–	2,6	13	0,1	3	LC..1603..
4	CFKN-04	–	–	48,6	–	3,6	15	0,1	4	LC..1604..
	CFNN-04	–	–	55,0	–	3,6	22	0,1	4	LC..1604..
5	CFIN-05	–	–	48,6	–	4,6	15	0,1	5	LC..1605..
6	CFHN-06	–	–	48,6	–	5,6	15	0,1	6	LC..1606..
	CFJN-06	–	–	55,0	–	5,6	22	0,1	6	LC..1606..

*Max depth of cut for LCMF16.. = 14 mm

Spare Parts, Parts included in delivery

For holder	Key	Locking screw	Screw
SFN2525N	T20P-7	C46017-T20P	C45013-T20P

Please check availability in current price and stock-list

Blades for inserts LCGN, LCMF and LCMR



- For insert programme, see page(s) 578-591, 593-594

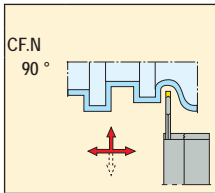
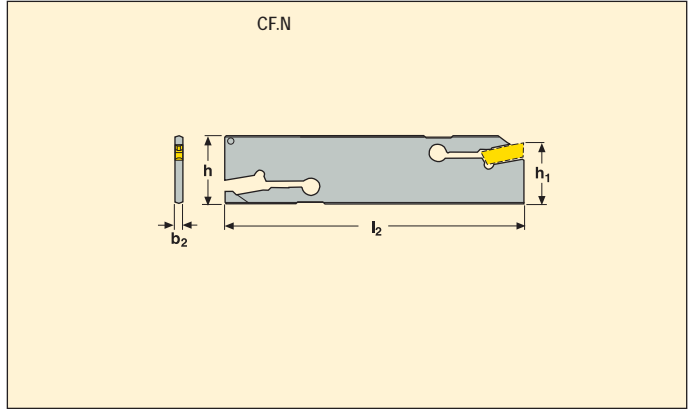

	Part No.	Dimensions in mm					KG	Seat size	
		b ₂	l ₂	h ₁	h	D _m			
3	CFMN26-03	2,4	110	21,4	26	25	0,1	3	LC..1603..
	CFON32-03	2,4	150	24,8	32	34	0,1	3	LC..1603..
4	CFMN32-04	3,0	150	24,8	32	34	0,1	4	LC..1604..
5	CFMN32-05	4,0	150	24,8	32	48	0,2	5	LC..1605..
6	CFKN32-06	5,0	150	24,8	32	48	0,2	6	LC..1606..

D_m max for LCMF16.. = 28 mm

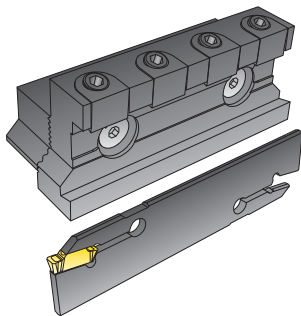

To be used in standard 150.10 holder
 CF..26... to be used in 150.10-...-20
 CF..32... to be used in 150.10-...-25

LCMF and LCMR

Tolerances:
 $a_p = \pm 0,05$
 $l = \pm 0,08$
 $s = \pm 0,05$

l = Distance cutting edge-rear support

Size	Dimensions in mm			
	a_p	l	s	rep
1303	3,00	12,35	4,00	0,2-0,4
1304	4,00	12,35	4,00	0,2-0,4

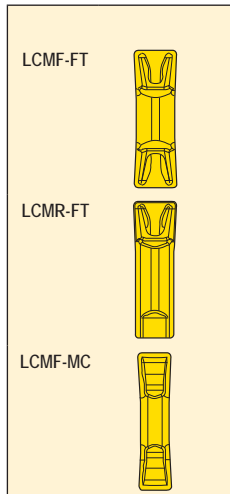

Inserts	Part No.	Grades																	
		Coated					Uncoated												
		CP200	CP500	CP600	TGK1500	TGP25	883	890											
LCMF-FT	LCMF 130302-0300-FT		■																
	LCMF 130304-0300-FT		■		■	■													
	LCMF 130402-0400-FT		■																
	LCMF 130404-0400-FT		■		■	■													
LCMR-FT	LCMR 130302-0300-FT		■																
	LCMR 130304-0300-FT		■																
	LCMR 130404-0400-FT		■																
LCMF-MC	LCMF 130304-0300-MC		■			■													
	LCMF 130404-0400-MC		■				■												

■ Stock standard
 Subject to change refer to current price- and stock-list

LCGF

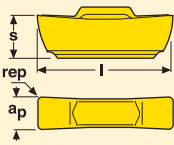

Tolerances:
 $a_p = \pm 0,025$
 $l = \pm 0,025$
 $s = \pm 0,05$

l = Distance cutting edge-rear support

Size	Dimensions in mm			
	a_p	l	s	rep
1303	3,000	12,350	3,90	0,2
1304	4,000	12,350	3,90	0,2

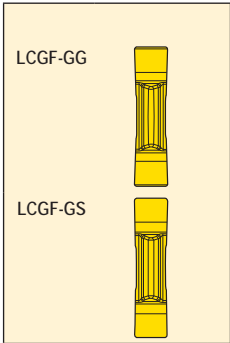

Inserts	Part No.	Grades																		
		Coated					Uncoated													
		CP200	CP500	CP600	TCK1500	TGP25			883	890										
LCGF-GG	LCGF 130302-0300-GG		■																	
	LCGF 130402-0400-GG		■																	
LCGF-GS	LCGF 130302-0300-GS												■							
	LCGF 130402-0400-GS												■							

■ Stock standard
 Subject to change refer to current price- and stock-list

LCMF and LCMR

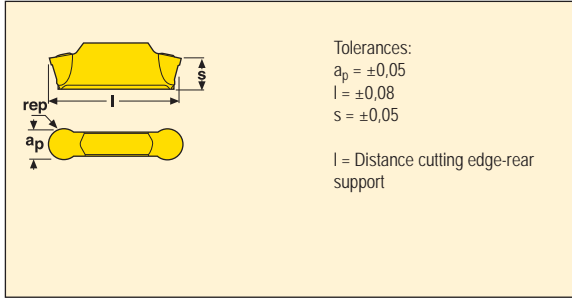

Size	Dimensions in mm			
	a_p	l	s	rep
1303	3,00	12,35	4,00	1,5-2,0
1304	4,00	12,35	4,00	1,5-2,0

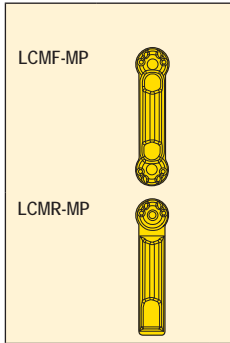

Inserts	Part No.	Grades																			
		Coated					Uncoated														
		CP200	CP500	CP600	TGK1500	TGP25						883	890								
LCMF-MP	LCMF 1303M0-0300-MP		■		■	■															
	LCMF 1304M0-0400-MP		■		■	■															
LCMR-MP	LCMR 1303M0-0300-MP		■																		
	LCMR 1304M0-0400-MP		■																		

■ Stock standard
 Subject to change refer to current price- and stock-list

LCGA

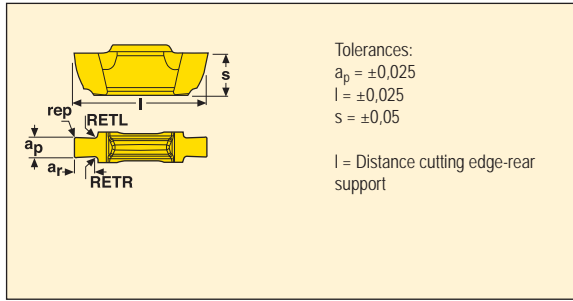

Size	Dimensions in mm						
	a_p	l	s	RETR	RETL	rep	a_r
-0115	1,150	12,350	4,00	0,3	0,3	-	1,40
-0135	1,350	12,350	4,00	0,3	0,3	-	1,60
-0165	1,650	12,350	4,00	0,3	0,3	0,10	1,90
-0190	1,900	12,350	4,00	0,3	0,3	0,10	2,15
-0215	2,150	12,350	4,00	0,3	0,3	0,15	2,40
-0265	2,650	12,350	4,00	0,2	0,2	0,20	2,90
01-0300	3,000	12,350	4,00	-	-	0,10	-
02-0300	3,000	12,350	4,00	-	-	0,20	-
-0400	4,000	12,350	4,00	-	-	0,20	-

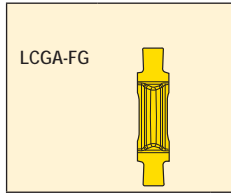

Inserts	For circlip	Part No.	Note	Standard	Grades							
					Coated							
					CP200	CP500	CP600	TGK1500	TGP25			
LCGA-FG	1,00	LCGA 130300-0115-FG	*	**	■							
	1,20	130300-0135-FG	*	**	■							
	1,50	130301-0165-FG	*	**	■							
	1,75	130301-0190-FG	*	**	■							
	2,00	130301-0215-FG	*	**	■							
	2,50	130302-0265-FG		**	■							
	-	130301-0300-FG		**	■							
	-	130302-0300-FG		**	■							
	-	LCGA 130402-0400-FG		**	■							

Standard
 ** =
 DIN 471
 DIN 472
 SMS 1581
 SMS 1582

■ Stock standard
 Subject to change refer to current price- and stock-list

*Toolholders have to be modified

LCMF

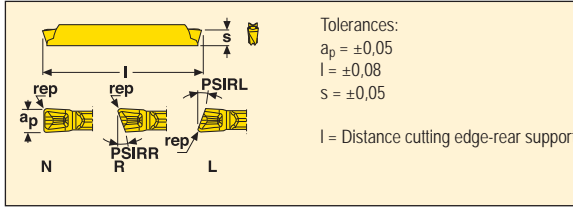

Size	Dimensions in mm			
	a_p	l	s	rep
1902	2,00	18,50	2,85	0,2
2802	2,00	28,00	2,85	0,2

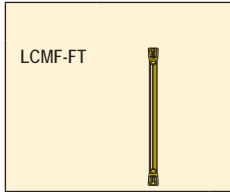

Inserts	Part No.	PSIRR°	PSIRL°	Grades						
				Coated						
				CP200	CP500	CP600	TGK1500	TGP25		
LCMF-FT	LCMF 190202-0200-FT	-	-	■	■					
	190202-0200-FTR6	6	-		■					
	190202-0200-FTL6	-	6		■					
LCMF	LCMF 280202-0200-FT	-	-	■	■					
	280202-0200-FTR6	6	-		■					
	280202-0200-FTL6	-	6		■					

LCMF

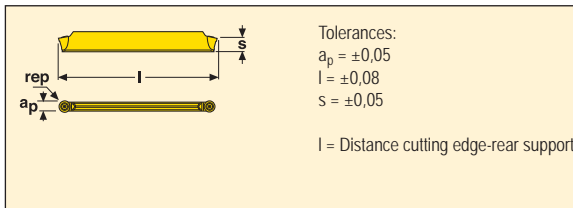

Size	Dimensions in mm			
	a_p	l	s	rep
1902	2,00	18,50	2,85	1,0
2802	2,00	28,00	2,85	1,0

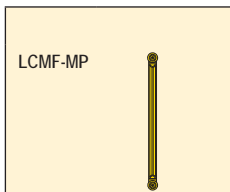

Inserts	Part No.	Grades					
		Coated					
		CP200	CP500	CP600	TGK1500	TGP25	TGS1050
LCMF-MP	LCMF 1902M0-0200-MP		■		■		
	LCMF 2802M0-0200-MP		■		■		

■ Stock standard
 Subject to change refer to current price- and stock-list

LCMF

Tolerances:
 $a_p = \pm 0,05$
 $l = \pm 0,08$
 $s = \pm 0,05$
 $s = \pm 0,08$

Size:
 16
 30

l = Distance cutting edge-rear support

Size	Inch version	Dimensions in mm			
		a_p	l	s	rep
1603		3,00	15,90	4,50	0,2-0,4
1604		4,00	15,90	4,50	0,2-0,8
1605		5,00	15,90	4,50	0,4-0,8
1606		6,00	15,90	4,50	0,4-1,0
3008-08		8,00	29,06	5,57	0,4-1,2
3008-10		10,00	29,21	5,57	0,8-1,2
1603	■	3,18	15,90	4,50	0,2
1605	■	4,76	15,90	4,50	0,5
1606	■	6,35	15,90	4,50	0,5

LCMF-FT

Inserts	Part No.	Grades																		
		Coated					Uncoated													
		CP200	CP500	CP600	TGK1500	TGP25			883	890										
LCMF-FT mm-version	LCMF 160302-0300-FT	■	■			■														
	LCMF 160304-0300-FT		■			■														
	LCMF 160402-0400-FT		■			■														
	LCMF 160404-0400-FT	■	■			■														
	LCMF 160408-0400-FT		■			■														
	LCMF 160504-0500-FT		■	■			■													
	LCMF 160508-0500-FT			■			■													
	LCMF 160604-0600-FT			■			■													
	LCMF 160608-0600-FT		■	■			■												■	
	LCMF 160610-0600-FT			■			■													
	LCMF 300804-0800-FT			■			■												■	
	LCMF 300808-0800-FT			■			■												■	
LCMF 300808-1000-FT			■			■														
LCMF 300812-0800-FT			■			■													■	
LCMF 300812-1000-FT			■			■													■	
LCMF-FT inch-version	LCMF 160302-0318-FT	■	■																	
	LCMF 160505-0476-FT	■	■																	
	LCMF 160605-0635-FT	■	■																	

■ Stock standard
 Subject to change refer to current price- and stock-list

LCMF

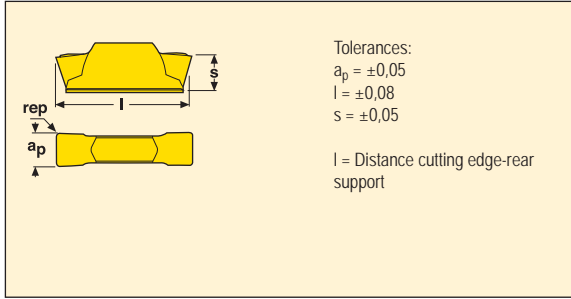

Size	Inch version	Dimensions in mm			
		a_p	l	s	rep
1603		3,00	15,90	4,50	0,2-0,4
1604		4,00	15,90	4,50	0,4-0,8
1605		5,00	15,90	4,50	0,4-0,8
1606		6,00	15,90	4,50	0,4-1,0
1603	■	3,18	15,90	4,50	0,2
1605	■	4,76	15,90	4,50	0,5
1606	■	6,35	15,90	4,50	0,5

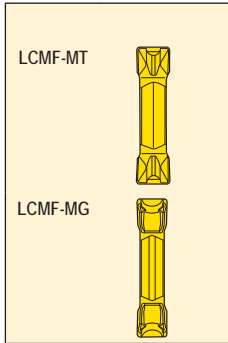

Inserts	Part No.	Grades																		
		Coated					Uncoated													
		CP200	CP500	CP600	TGK1500	TGP25			883	890										
LCMF-MT mm-version	LCMF 160302-0300-MT		■			■														
	160304-0300-MT		■			■	■				■									
	LCMF 160404-0400-MT		■			■	■													
	160408-0400-MT		■			■	■				■									
	LCMF 160504-0500-MT		■			■	■													
	160508-0500-MT		■			■	■					■								
	LCMF 160604-0600-MT		■			■	■													
	160608-0600-MT		■			■	■					■								
160610-0600-MT		■				■														
LCMF-MT inch-version	LCMF 160302-0318-MT		■																	
	LCMF 160505-0476-MT		■																	
	LCMF 160605-0635-MT		■									■								
LCMF-MG	LCMF 160304-0300-MG		■				■													
	LCMF 160404-0400-MG		■				■													
	LCMF 160504-0500-MG		■				■													
	LCMF 160608-0600-MG		■				■													

■ Stock standard
 Subject to change refer to current price- and stock-list

LCMF and LCMR

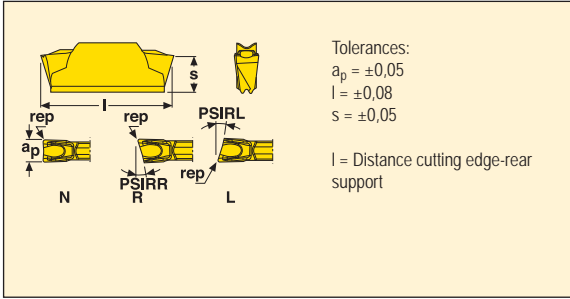

Size	Dimensions in mm			
	a_p	l	s	rep
1603	3,00	15,90	4,50	0,2-0,4
1604	4,00	15,90	4,50	0,2-0,4
1605	5,00	15,90	4,50	0,4
1606	6,00	15,90	4,50	0,4-0,8

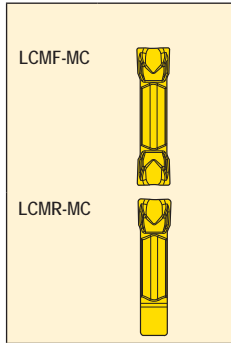

Inserts	Part No.	PSIRR°	PSIRL°	Note	Grades														
					Coated														
					CP200	CP500	CP600	TGK1500	TGP25										
LCMF-MC	LCMF 160302-0300-MC	-	-		■	■													
	160302-0300-MCR6	6	-		■	■													
	160302-0300-MCL6	-	6		■	■													
	160302-0300-MCR15	15	-	*			■												
	160302-0300-MCL15	-	15	*			■												
	160304-0300-MC	-	-		■	■			■										
	LCMF 160402-0400-MC	-	-		■	■													
	160402-0400-MCR6	6	-	*	■	■													
	160402-0400-MCL6	-	6	*			■												
	160402-0400-MCR15	15	-	*			■												
160402-0400-MCL15	-	15	*			■													
160404-0400-MC	-	-			■	■			■										
LCMF 160504-0500-MC	-	-			■	■			■										
LCMF 160604-0600-MC	-	-			■	■			■										
160608-0600-MC	-	-			■	■			■										
LCMR-MC	LCMR 160302-0300-MC	-	-				■												
	LCMR 160404-0400-MC	-	-				■												
	LCMR 160504-0500-MC	-	-				■												
	LCMR 160604-0600-MC	-	-				■												

■ Stock standard
 Subject to change refer to current price- and stock-list

*Toolholders have to be modified

LCMR

Tolerances:
 $a_p = \pm 0,05$
 $l = \pm 0,08$
 $s = \pm 0,05$
 $s = \pm 0,08$

Size:
 16
 30

l = Distance cutting edge-rear support

Size	Dimensions in mm			
	a_p	l	s	rep
1603	3,00	15,90	4,50	0,4
1604	4,00	15,90	4,50	0,2-0,8
1605	5,00	15,90	4,50	0,4-0,8
1606	6,00	15,90	4,50	0,8
3008-08	8,00	29,06	5,57	0,8-1,2
3008-10	10,00	29,21	5,57	0,8-1,2

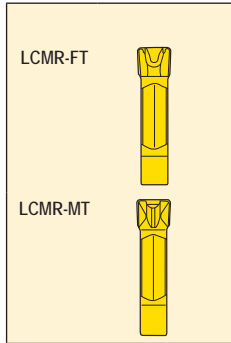

Inserts	Part No.	Grades																		
		Coated					Uncoated													
		CP200	CP500	CP600	TGK1500	TGP25			883	890										
LCMR-FT	LCMR 160304-0300-FT	■	■			■														
	LCMR 160402-0400-FT		■																	
	LCMR 160404-0400-FT	■	■			■														
	LCMR 160504-0500-FT	■	■			■														
	LCMR 160608-0600-FT	■	■			■														
	LCMR 300808-0800-FT		■			■						■								
	LCMR 300808-1000-FT		■																	
	LCMR 300812-0800-FT		■																	
	LCMR 300812-1000-FT		■																	
LCMR-MT	LCMR 160304-0300-MT		■			■						■								
	LCMR 160404-0400-MT		■			■														
	LCMR 160408-0400-MT											■								
	LCMR 160504-0500-MT		■			■														
	LCMR 160508-0500-MT											■								
	LCMR 160608-0600-MT		■			■						■								

■ Stock standard
 Subject to change refer to current price- and stock-list

LCMR

Tolerances:
 $a_p = \pm 0,05$
 $l = \pm 0,08$
 $s = \pm 0,05$
 $s = \pm 0,08$

Size:
 16
 30

l = Distance cutting edge-rear support

Size	Dimensions in mm			
	a_p	l	s	rep
1603	3,00	16,98	4,30	1,5
1604	4,00	17,09	4,25	2,0
1605	5,00	17,75	4,17	2,5
1606	6,00	17,98	4,12	3,0
3008...08	8,00	30,06	5,42	4,0
3008...10	8,00	30,05	5,49	5,0

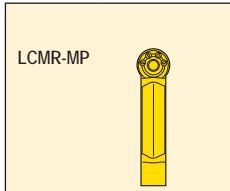

Inserts	Part No.	Grades																			
		Coated					Uncoated														
		CP200	CP500	CP600	TGK1500	TGP25				883	890										
LCMR-MP	LCMR 1603M0-0300-MP	■	■			■				■											
	LCMR 1604M0-0400-MP	■	■			■				■											
	LCMR 1605M0-0500-MP	■	■			■				■											
	LCMR 1606M0-0600-MP	■	■			■				■											
	LCMR 3008M0-0800-MP		■			■				■											
	3008M0-1000-MP		■			■															

■ Stock standard
 Subject to change refer to current price- and stock-list

LCGF

Tolerances:
 $a_p = \pm 0,025$
 $l = \pm 0,025$
 $s = \pm 0,05$

l = Distance cutting edge-rear support

Size	Dimensions in mm			
	a_p	l	s	rep
1603	3,000	16,600	4,25	0,2
1604	4,000	16,600	4,25	0,2
1605	5,000	17,100	4,15	0,2
1606	6,000	17,400	4,20	0,4
3008	8,000	29,000	5,55	0,4

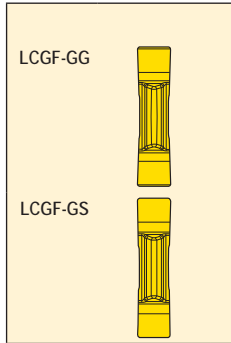

Inserts	Part No.	Grades																			
		Coated					Uncoated														
		CP200	CP500	CP600	TGK1500	TGP25			883	890											
LCGF-GG	LCGF 160302-0300-GG		■																		
	LCGF 160402-0400-GG		■																		
	LCGF 160502-0500-GG		■																		
	LCGF 160604-0600-GG		■																		
	LCGF 300804-0800-GG		■																		
LCGF-GS	LCGF 160302-0300-GS																				■
	LCGF 160402-0400-GS																				■
	LCGF 160502-0500-GS																				■
	LCGF 160604-0600-GS																				■
	LCGF 300804-0800-GS																				■

■ Stock standard
 Subject to change refer to current price- and stock-list

LCGF

Tolerances:
 $a_p = \pm 0,02$
 $l = \pm 0,04$
 $s = \pm 0,05$
 $s = \pm 0,08$

Size:
 16
 30

l = Distance cutting edge-rear support

Size	Inch version	Dimensions in mm			
		a_p	l	s	rep
1603		3,00	16,98	4,30	1,50
1604		4,00	17,09	4,25	2,00
1605		5,00	17,75	4,17	2,50
1606		6,00	17,98	4,12	3,00
3008...08		8,00	30,06	5,42	4,00
3008...10		10,00	30,05	5,49	5,00
1603	■	3,18	16,64	4,36	1,59
1605	■	4,76	17,67	4,17	2,38

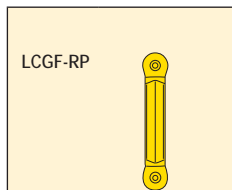

Inserts	Part No.	Grades																		
		Coated					Uncoated													
		CP200	CP500	CP600	TGKT1500	TGP25				883	890									
LCGF-RP mm-version	LCGF 1603M0-0300-RP	■									■									
	LCGF 1604M0-0400-RP	■										■								
	LCGF 1605M0-0500-RP	■											■							
	LCGF 1606M0-0600-RP	■											■							
	LCGF 3008M0-0800-RP	■												■						
	LCGF 3008M0-1000-RP	■													■					
LCGF-RP inch-version	LCGF 160300-0318-RP	■												■						
	LCGF 160500-0476-RP	■													■					

■ Stock standard
 Subject to change refer to current price- and stock-list

LCGN and LCGF – Radial grooves

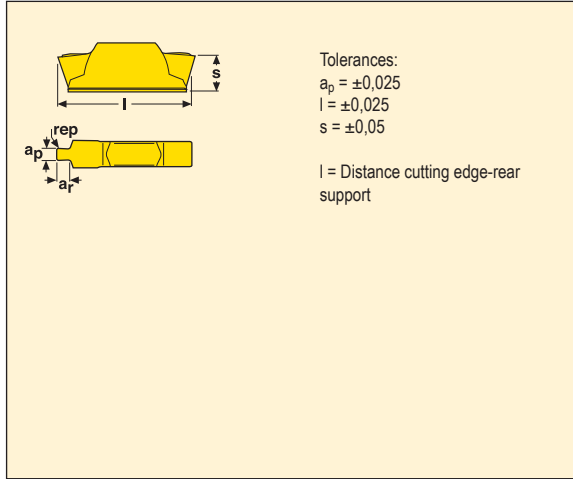

Size	Dimensions in mm				
	a_p	l	s	rep	a_r
-0115	1,150	16,600	4,50	–	1,40
-0135	1,350	16,600	4,50	–	1,60
-0165	1,650	16,600	4,50	0,1	1,85
-0190	1,900	16,600	4,50	0,1	2,10
-0215	2,150	16,600	4,50	0,1	2,30
-0265	2,650	16,600	4,50	0,2	–
01-0300	3,000	16,600	4,50	0,1	–
02-0300	3,000	16,600	4,50	0,2	–
-0320	3,200	16,600	4,50	0,2	–
-0340	3,400	16,600	4,50	0,2	–
-0400	4,000	16,600	4,50	0,2	–
-0420	4,200	16,600	4,50	0,2	–
-0440	4,400	16,600	4,50	0,2	–
-0500	5,000	17,100	4,50	0,2	–
-0520	5,200	17,100	4,50	0,2	–
-0600	6,000	17,600	4,50	0,2	–
-0635	6,350	17,600	4,50	0,2	–

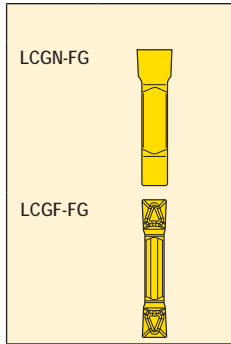

Standard
 ** =
 DIN 471
 DIN 472
 SMS 1581
 SMS 1582

Inserts	For circlip	Part No.	Note	Standard	Grades								
					Coated								
					CP200	CP500	CP600	TGK1500	TGP25				
LCGN-FG	1,00	LCGN 160300-0115-FG	*	**		■							
	1,20	160300-0135-FG	*	**		■							
	1,50	160301-0165-FG	*	**		■							
	1,75	160301-0190-FG	*	**		■							
	2,00	160301-0215-FG	*	**		■							
	2,50	160302-0265-FG		**		■							
	–	160302-0300-FG		**		■							
	3,00	160302-0320-FG		**		■							
	–	160302-0340-FG		**		■							
	–	LCGN 160402-0400-FG		**		■							
	4,00	160402-0420-FG		**		■							
	–	160402-0440-FG		**		■							
	–	LCGN 160502-0500-FG		**		■							
	5,00	160502-0520-FG		**		■							
–	LCGN 160602-0600-FG		**		■								
–	160602-0635-FG		**		■								
LCGF-FG	–	LCGF 160301-0300-FG				■							

■ Stock standard
 Subject to change refer to current price- and stock-list

*Toolholders have to be modified

LCGN - O-ring

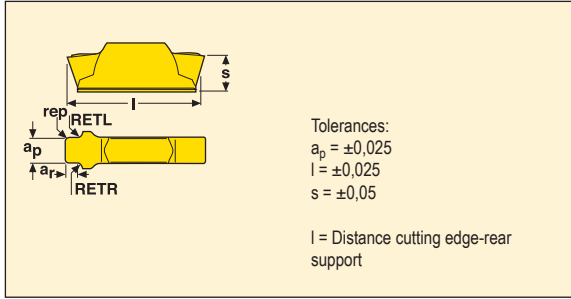

Size	Dimensions in mm						
	a_p	l	s	RETR	RETL	rep	a_r
0180-DY	2,400	16,600	4,50	0,3	0,3	0,50	1,55
0240-DY	3,300	16,600	4,50	0,3	0,3	0,50	2,00
0265-DY	3,600	16,600	4,50	0,3	0,3	0,50	2,30
0300-DY	4,100	16,600	4,50	0,3	0,3	1,00	2,50
0160-ST	2,400	16,600	4,50	0,3	0,3	0,50	1,20
0240-ST	3,200	16,600	4,50	0,3	0,3	0,50	1,90
0300-ST	3,800	16,600	4,50	0,3	0,3	1,00	2,40
0355-ST	4,800	17,100	4,50	0,3	0,3	0,75	2,80

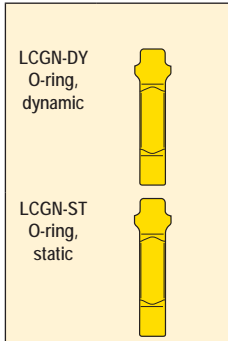

Inserts	For O-ring mm	For O-ring inch	Standard	Part No.	Grades									
					Coated									
					CP200	CP500	CP600	TGK1500	TGP25					
LCGN-DY O-ring, dynamic	1,80	0.071	**	LCGN 160305-0180-DY	■									
	2,40	-	*	LCGN 160405-0240-DY	■									
	2,65	0.104	**	160405-0265-DY	■									
	3,00	-	*	160410-0300-DY	■									
LCGN-ST O-ring, static	1,60	-	*	LCGN 160305-0160-ST	■									
	2,40	-	*	160305-0240-ST	■									
	3,00	-	*	LCGN 160410-0300-ST	■									
	3,55	0.140	**	LCGN 160507-0355-ST	■									

Standard
 * =
 SMS 1588
 BS 4518

** =
 ISO 3601
 DIN 3771
 BS 1806

■ Stock standard
 Subject to change refer to current price- and stock-list

LCGN – Full radius grooving

Tolerances:
 $l = \pm 0,025$
 $s = \pm 0,05$

l = Distance cutting edge-rear support

Right-hand version shown

Size	Dimensions in mm			
	l	s	rep	a_r
-0100	16,600	4,50	1,0	2,7
-0120	16,600	4,50	1,2	2,7
-0150	16,600	4,50	1,5	–
-0200	16,600	4,50	2,0	–
-0300	17,600	4,50	3,0	–

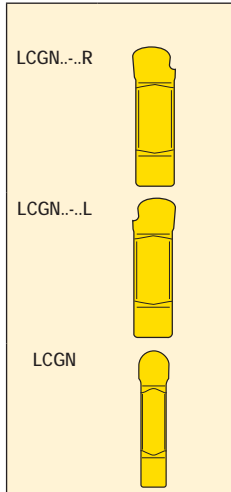

Inserts	For radius mm	Part No.	Note	Grades							
				Coated							
				CP200	CP500	CP600	TGK1500	TGP25			
LCGN-R	1,0	LCGN 1603M0-0100R-R	*	■							
	1,2	1603M0-0120R-R	*	■							
	1,0	LCGN 1603M0-0100L-R	*	■							
	1,2	1603M0-0120L-R	*	■							
	1,5	LCGN 1603M0-0150-R		■							
	2,0	LCGN 1604M0-0200-R		■							
	3,0	LCGN 1606M0-0300-R		■							

■ Stock standard
 Subject to change refer to current price- and stock-list

*Toolholders have to be modified

LCGN-D76

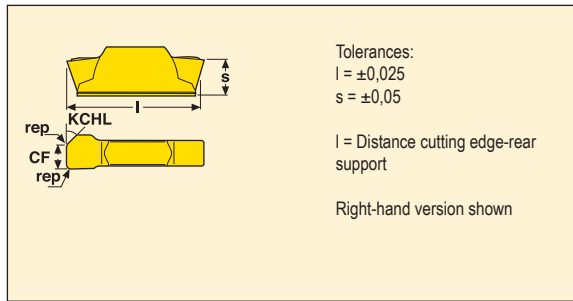

Size	Dimensions in mm			
	CF	l	s	rep
1603	2,2	16,600	4,50	0,60
1605	3,2	17,100	4,50	0,75
1606	4,6	17,600	4,50	1,00

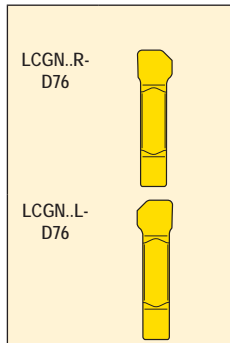

Inserts	For max pitch	Part No.	KCHR°	KCHL°	Note	Grades					
						Coated					
						CP200	CP500	CP600	TGK1500	TGP25	
LCGN-D76	1,0	LCGN 160306-0100R-D76	–	45	*	■					
	1,0	LCGN 160306-0100L-D76	45	–	*	■					
	1,5	LCGN 160507-0150R-D76	–	45		■					
	1,5	LCGN 160507-0150L-D76	45	–		■					
	2,0	LCGN 160610-0200R-D76	–	45		■					
	2,0	LCGN 160610-0200L-D76	45	–		■					

■ Stock standard
 Subject to change refer to current price- and stock-list
 *Toolholders have to be modified

LCGN – Partial profile 55°

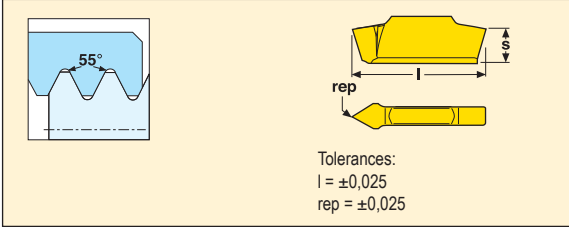

Size	Dimensions in mm		
	l	s	rep
-A55	16,600	4,50	0,080
-G55	16,600	4,50	0,180



Inserts	Pitch mm	TPI	Part No.	Grades					
				Coated					
				CP200	CP500	CP600	TGK1500	TGP25	
LCGN...-.55	0,50-1,50	48-16	LCGN 1603-A55	■					
	1,75-3,00	14-8	1603-G55	■					

LCGN – Partial profile 60°

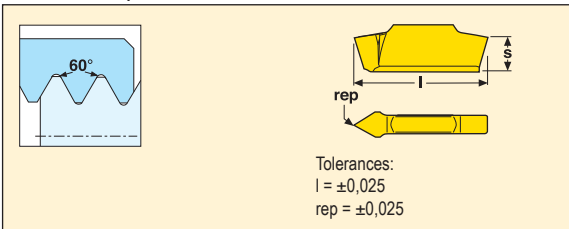

Size	Dimensions in mm		
	l	s	rep
-A60	16,600	4,50	0,080
-G60	16,600	4,50	0,180

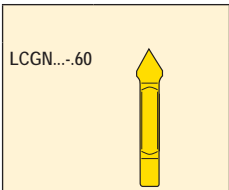

Inserts	Pitch mm	TPI	Part No.	Grades					
				Coated					
				CP200	CP500	CP600	TGK1500	TGP25	
LCGN...-.60	0,50-1,50	48-16	LCGN 1603-A60	■					
	1,75-3,00	14-8	1603-G60	■					

■ Stock standard
 Subject to change refer to current price- and stock-list

LCGN - ISO Metric

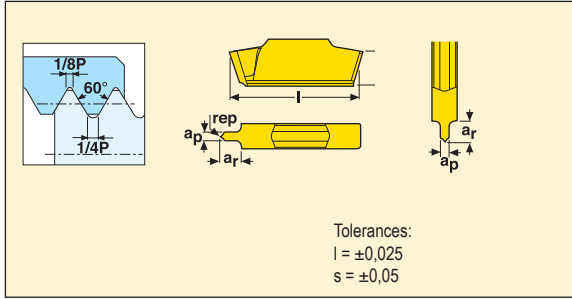

Size	Dimensions in mm				
	a_p	l	s	rep	a_r
-E0.5	0,75	16,600	4,50	0,07	1,90
-E0.8	1,20	16,600	4,50	0,11	3,00
-E1.0	1,50	16,600	4,50	0,13	3,75
-E1.25	1,88	16,600	4,50	0,17	4,20
-E1.5	2,40	16,600	4,50	0,21	-

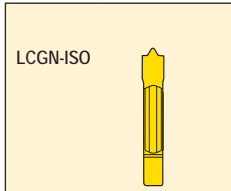

Inserts	Pitch mm	Part No.	Note	Grades				
				Coated				
				CP200	CP500	CP600	TGK1500	TGP25
LCGN-ISO	0,50	LCGN 1603-E0.5ISO	*	■				
	0,80	1603-E0.8ISO	*	■				
	1,00	1603-E1.0ISO	*	■				
	1,25	1603-E1.25ISO	*	■				
	1,50	1603-E1.5ISO	*	■				

■ Stock standard
 Subject to change refer to current price- and stock-list

*Toolholders have to be modified

LCGN

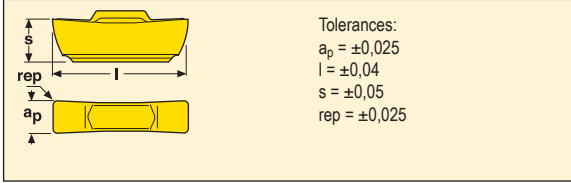

Size	Dimensions in mm			
	a_p	l	s	rep
1303	3,000	12,33	4,00	0,400
1304	4,000	12,33	4,00	0,400

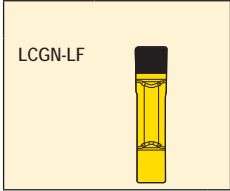

Inserts	Part No.	Grades			
		Uncoated			
		CBN010	CBN10	CBN170	CBN200
LCGN-LF	LCGN 130304-0300S-LF		■		■
	1303040300S01025LF	■			
LCGN-LF	LCGN 130404-0400S-LF		■		■
	1304040400S01025LF	■			

LCGN

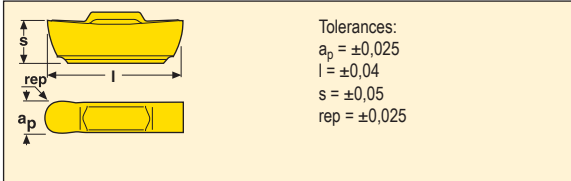

Size	Dimensions in mm			
	a_p	l	s	rep
1303	3,000	12,35	4,00	1,500
1304	4,000	12,35	4,00	2,000

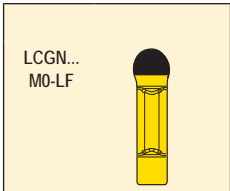

Inserts	Part No.	Grades			
		Uncoated			
		CBN010	CBN10	CBN170	CBN200
LCGN...MO-LF	LCGN 1303M0-0300S-LF		■		
	1303M00300S01025LF	■			
LCGN...MO-LF	LCGN 1304M0-0400S-LF		■		
	1304M00400S01025LF	■			

■ Stock standard
 Subject to change refer to current price- and stock-list

Tip sizes, see page(s) 70
 Edge preparation, see page(s) 67

LCGN

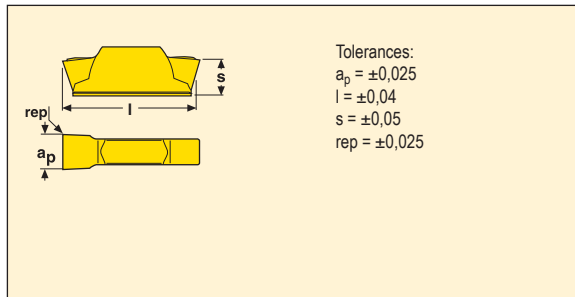

Size	Dimensions in mm			
	a_p	l	s	rep
1603	3,000	15,90	4,50	0,400
1604	4,000	15,90	4,50	0,400
1605	5,000	15,90	4,50	0,400
1606	6,000	15,90	4,50	0,400

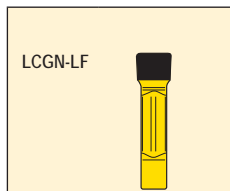

Inserts	Part No.	Grades			
		Uncoated			
		CBN010	CBN10	CBN170	CBN200
LCGN	160304-0300E-LF	■	■		
	160304-0300E25-LF			■	
	160304-0300S-LF				■
	160304-0300S01025LF	■			
LCGN	160404-0400E-LF	■	■		
	160404-0400E25-LF			■	
	160404-0400S-LF				■
	160404-0400S01025LF	■			
LCGN	160504-0500S-LF				■
	160504-0500S01025LF	■			
LCGN	160604-0600S-LF				■
	160604-0600S01025LF	■			

■ Stock standard
 Subject to change refer to current price- and stock-list

Tip sizes, see page(s) 70
 Edge preparation, see page(s) 67

LCGN

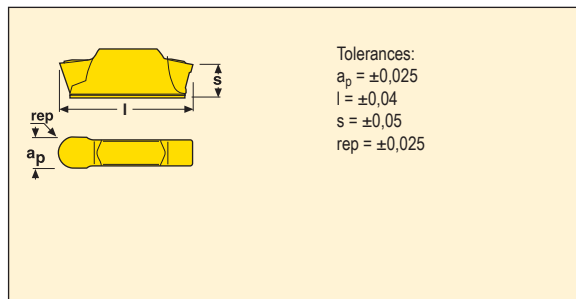

Size	Dimensions in mm			
	a_p	l	s	rep
1603	3,000	16,60	4,40	1,500
1604	4,000	16,60	4,35	2,000
1605	5,000	17,20	4,30	2,500
1606	6,000	17,20	4,20	3,000



Inserts	Part No.	Grades			
		Uncoated			
		CBN010	CBN10	CBN170	CBN200
LCGN...MO-LF	LCGN 1603MO-0300E25-LF	■	■	■	
	1603MO-0300S-LF				■
	1603MO-0300S01025LF	■			
LCGN	1604MO-0400E25-LF	■	■	■	
	1604MO-0400S-LF				■
	1604MO-0400S01025LF	■			
LCGN	1605MO-0500E25-LF	■	■	■	
	1605MO-0500S-LF				■
	1605MO-0500S01025LF	■			
LCGN	1606MO-0600E25-LF	■	■		
	1606MO-0600S-LF				■
	1606MO-0600S01025LF	■			

■ Stock standard
 Subject to change refer to current price- and stock-list

Tip sizes, see page(s) 70
 Edge preparation, see page(s) 67

General information

Seco Mini Shaft consists of holders and inserts for internal turning, grooving, precision grooving, profiling, backfacing and threading. To be used in holes as small as $\varnothing 8$ mm (Mini Shaft 08) or 11 mm (Mini Shaft 11).

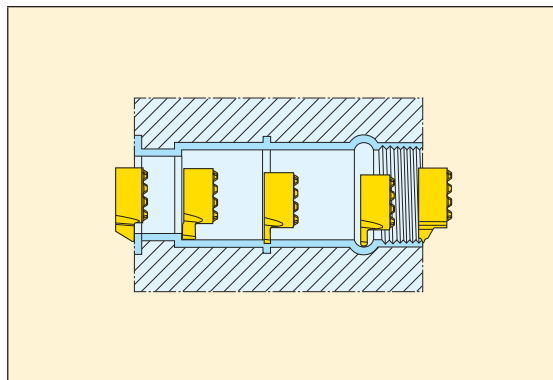
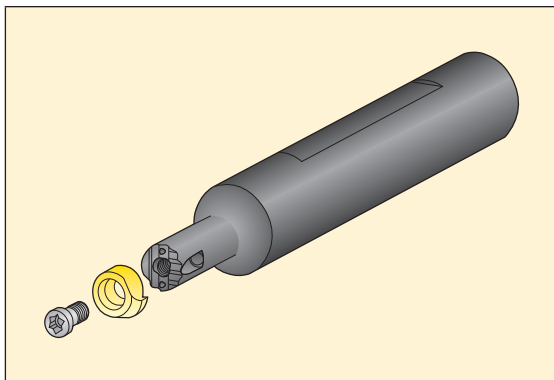

Seco Mini Shaft features a new type of joint, with a double serration, which makes the connection both stable and secure. It also gives very good repeatability (± 0.02 mm).

All toolholders are used for both R and L-handed inserts, and have through coolant possibility.

Toolholders

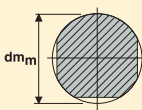
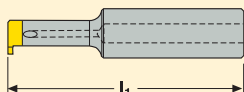
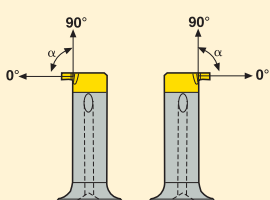
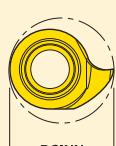
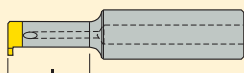

A	12	G	-	S	G	X	N	08	-	20	-	R
1	2	3		4	5	6	7	8		9		10

<p>1. Toolholder type</p> <p>A = Steel with coolant passage E = Solid carbide with brazed cutting head and coolant passage</p>	<p>2. Shank diameter</p>  <p>d_{mm}</p> <p>12 = 12 mm</p>	<p>3. Tool length</p>  <p>I_1</p> <p>G = 90 mm H = 100 mm</p>
<p>4. Insert clamping</p> <p>S = Screw</p>	<p>5. Toolholder setting angle</p>  <p>G = 0° F = 90°</p>	<p>6. Max grooving/turning depth</p> <p>X = Special</p>
<p>7. Version</p> <p>N = Neutral version</p>	<p>8. Insert size</p>  <p>DCINN</p> <p>08 = Insert size</p>	<p>9. Extension length</p>  <p>I</p> <p>20 = 20 mm</p>
<p>10. Internal designation</p> <p>R = Round</p>		

Inserts, turning and grooving

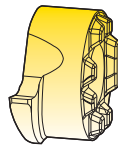

L	C	E	X	08	04	02	- 0150	R	- FG
1	2	3	4	5	6	7	8	9	10

1. Shape

L = Insert shape

2. Front clearance angle

C = 7°

3. Tolerances

	Tol. class	Tolerance ± mm		
		a _p	d	rep
E		0,025	0,025	0,025

4. Inserts type

X = Special

5. Insert size

DCINN

6. Thickness

t₁
t₂

04 = 3,95 mm
05 = 4,85 mm

7. Corner radius

rep

8. Insert width

0075 = 0,75 mm
0080 = 0,80 mm
0090 = 0,90 mm
etc

9. Version

R L

10. Inserts type code

FG = For locking
R = Full radius
etc

Inserts, threading

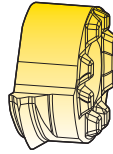

L	C	E	X	11	05	-	1.5	ISO	R
1	2	3	4	5	6		7	8	9

1. Shape



L = Insert shape

2. Front clearance angle

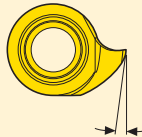

C = 7°

3. Tolerances

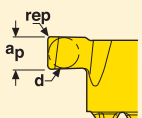
	Tol. class	Tolerance ± mm		
		a _p	d	rep
	E	0,025	0,025	0,025

4. Inserts type

X = Special

5. Insert size

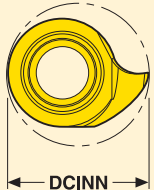

DCINN

6. Thickness



l₁

04 = 3,95 mm
05 = 4,85 mm

7. Pitch

Full profile: (mm)	1.0	1.5	2.0	2.5	3.0
Part profile: (mm)	A = 0,50 - 0,75	AG = 0,75 - 1,25	G = 1,25 - 1,75		
Full profile: (TPI)	14	19			

etc

8. Insert width

Thread =

60 = V profile 60°
ISO = ISO, metric
W = Whitworth, BSW
TR = Trapezoidal, DIN 103

etc

9. Version

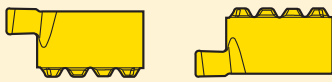

R L

Tool blocks, adapters

Holders should be mounted in standard turrets. Sometimes there is a need for additional set-up devices, such as tool blocks and adapters.

Shown opposite is the Seco solution for bars to be mounted into a turret for standard square shanks 131-.. to be used together with fully cylindrical shanks (-R) and shanks with flats.

Adapters SL16.. to be used with shanks with flats.

Please see page(s) 342.



Collet chucks

Fully cylindrical shanks (-R) can also be mounted in collet chucks.

- Use collets or reduction sleeves for hydraulic chucks
- Round shanks combined with collets can prevent vibrations
- Shanks with flats may not be used in collets – as there is a risk of damaging the collet



Set-up device for cylindrical shanks

To obtain an accurate centering of the cutting edge use a set-up device.



Accessories

Setting gauge	Part No.	
	LCEX 0804-N	■
	1105-N	■

■ Stock standard
 Subject to change refer to current price- and stock-list

Cutting speed, v_c (m/min)

In this section a recommended cutting speed is indicated under specified conditions.

Use the tables beginning on page(s) 688 to classify the workpiece material into a SMG.

The cutting data tables provide a start value for feed rate (f) and cutting speed (v_c) for the selected cutting width (a_p).

The cutting data tables are based on grooving with full cutting width.

The recommended cutting speeds in the tables are calculated for 15 minutes tool life with use of external flood coolant.

In order to increase the accuracy towards the actual cutting conditions and requirements of the applications the recommendation is to use My Pages – Suggest on www.secotools.com

v_c = cutting speed (m/min)

a_p = insert width (mm)

f = feed rate (mm/rev)

SMG		$a_p = 0.75-3.00$	
		f	v_c
P1	CP500	0,022	150
P2	CP500	0,022	150
P3	CP500	0,020	130
P4	CP500	0,020	115
P5	CP500	0,020	110
P6	CP500	0,020	120
P7	CP500	0,020	115
P8	CP500	0,020	110
P11	CP500	0,020	110
M1	CP500	0,022	90
M2	CP500	0,020	65
M3	CP500	0,016	41
M4	CP500	0,014	27
M5	CP500	0,014	22
K1	CP500	0,022	160
K2	CP500	0,020	130
K3	CP500	0,020	110
K4	CP500	0,020	105
K5	CP500	0,018	65
K6	CP500	0,020	105
K7	CP500	0,018	85
N11	CP500	0,028	95
S1	CP500	0,014	18
S2	CP500	0,014	15
S3	CP500	0,013	13

Toolholders for inserts LCEX



• For insert programme, see page(s) 602-609

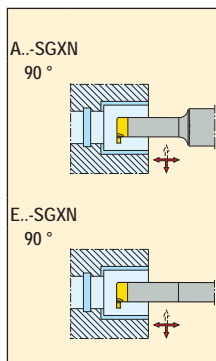
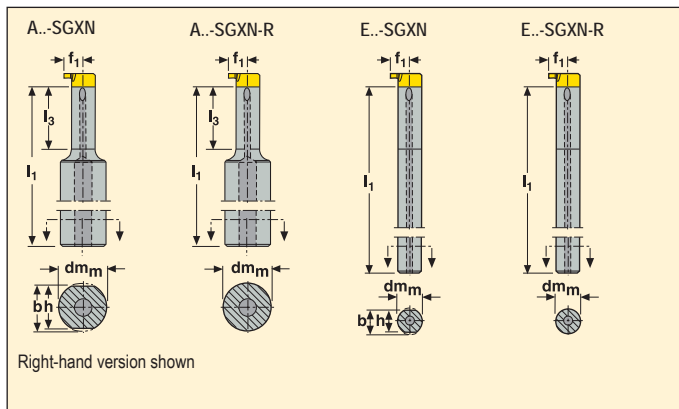

	Part No.	Dimensions in mm							KG	
		dm	h	b	l ₁	f ₁	l ₃	DCINN		
08	A12G-SGXN08-20	12	11,0	11,50	86,5	4,8	16,5	8	0,1	LCEX08..
	A12G-SGXN08-20-R	12	-	-	86,5	4,8	16,5	8	0,1	LCEX08..
11	A16H-SGXN11-25	16	15,0	15,50	96,0	6,7	21,0	11	0,2	LCEX11..
	A16H-SGXN11-25-R	16	-	-	96,0	6,7	21,0	11	0,2	LCEX11..
08	E06G-SGXN08	6	5,5	5,75	86,5	4,8	-	8	0,1	LCEX08..
	E06G-SGXN08-R	6	-	-	86,5	4,8	-	8	0,1	LCEX08..
11	E08H-SGXN11	8	7,3	7,65	96,0	6,7	-	11	0,1	LCEX11..
	E08H-SGXN11-R	8	-	-	96,0	6,7	-	11	0,1	LCEX11..

Spare Parts, Parts included in delivery

For holder	Insert key	Insert screw
A12G..	T08P-2	C02506-T08P
A16H..	T10P-2	C03509-T10P
E06G..	T08P-2	C02506-T08P
E08H..	T10P-2	C03509-T10P

Please check availability in current price and stock-list

Turning

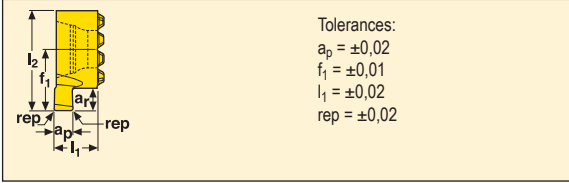

Size	Dimensions in mm	
	l_2	f_1
0804	7,78	4,78
1105	10,70	6,70

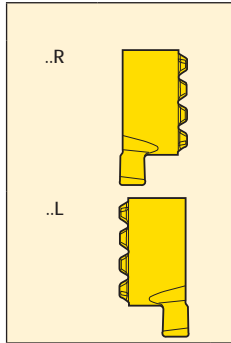

Inserts	Dimensions in mm				Part No.	Grades					
	a_p	a_r	l_1	rep		Coated					
LCEX						CP500					
	2,00	1,70	3,30	0,10	LCEX 080401-0200R	■					
	2,00	1,70	3,30	0,10	080401-0200L	■					
	1,50	1,70	3,30	0,20	LCEX 080402-0150R	■					
	1,50	1,70	3,30	0,20	080402-0150L	■					
	2,00	2,60	4,00	0,10	LCEX 110501-0200R	■					
	2,00	2,60	4,00	0,10	110501-0200L	■					
	1,50	2,60	4,00	0,20	LCEX 110502-0150R	■					
	1,50	2,60	4,00	0,20	110502-0150L	■					

Profiling

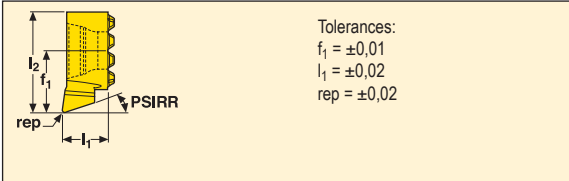

Size	Dimensions in mm	
	l_2	f_1
0804	7,78	4,78
1105	10,70	6,70

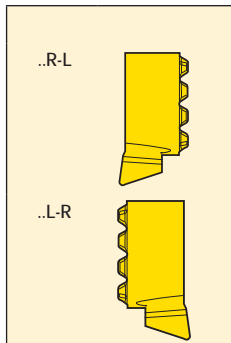

Inserts	Dimensions in mm				Part No.	Grades					
	l_1	rep	PSIRR°	PSIRL°		Coated					
LCEX						CP500					
	3,55	0,20	18	0	LCEX 080402-0250R-L18	■					
	3,55	0,20	0	18	080402-0250L-R18	■					
	3,45	0,20	47	0	LCEX 080402-0250R-L47	■					
	3,45	0,20	0	47	080402-0250L-R47	■					
	4,25	0,20	18	0	LCEX 110502-0270R-L18	■					
	4,25	0,20	0	18	110502-0270L-R18	■					
	4,15	0,20	47	0	LCEX 110502-0250R-L47	■					
	4,15	0,20	0	47	110502-0250L-R47	■					

■ Stock standard

Subject to change refer to current price- and stock-list

Back facing

Tolerances:
 $f_1 = \pm 0,01$
 $l_1 = \pm 0,02$
 $rep = \pm 0,02$

Size	Dimensions in mm	
	l_2	f_1
0804	7,78	4,78
1105	10,70	6,70

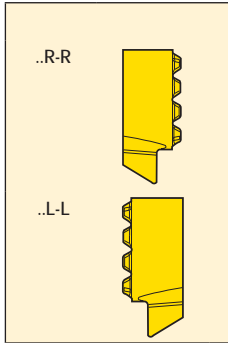

Inserts	Dimensions in mm				Part No.	Grades			
	l_1	rep	PSIRR°	PSIRL°		Coated			
						CP500			
LCEX	0,75	0,20	0	30	LCEX 080402-0250R-R30	■			
	0,75	0,20	30	0	080402-0250L-L30	■			
	1,25	0,20	0	30	LCEX 110502-0270R-R30	■			
	1,25	0,20	30	0	110502-0270L-L30	■			

Chamfering

Tolerances:
 $f_1 = \pm 0,01$
 $l_1 = \pm 0,05$
 $rep = \pm 0,02$

Size	Dimensions in mm	
	l_2	f_1
0804	7,78	4,78
1105	10,70	6,70

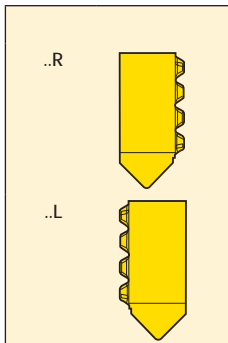

Inserts	Dimensions in mm				Part No.	Grades			
	l_1	rep	PSIRR°	PSIRL°		Coated			
						CP500			
LCEX	1,70	0,20	45	45	LCEX 080402-0310R-N45	■			
	1,70	0,20	45	45	080402-0310L-N45	■			
	2,20	0,20	45	45	LCEX 110502-0350R-N45	■			
	2,20	0,20	45	45	110502-0350L-N45	■			

■ Stock standard
 Subject to change refer to current price- and stock-list

Full radius grooves

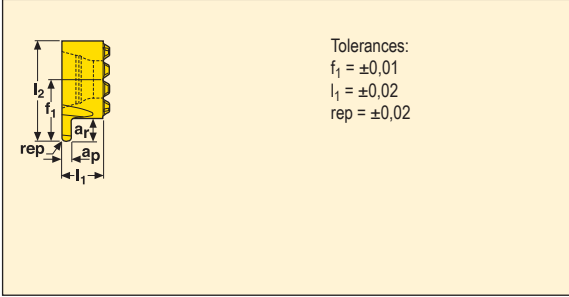

Size	Dimensions in mm	
	l_2	f_1
0804	7,78	4,78
1105	10,70	6,70

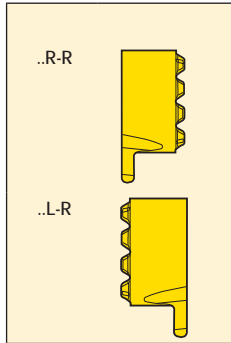

Inserts	Dimensions in mm				Part No.	Grades					
	a_p	a_r	l_1	rep		CP500	Coated				
LCEX	0,80	1,70	3,30	0,40	LCEX 080404-0080R-R	■					
	0,80	1,70	3,30	0,40	080404-0080L-R	■					
	1,20	1,70	3,30	0,60	LCEX 080406-0120R-R	■					
	1,20	1,70	3,30	0,60	080406-0120L-R	■					
	1,80	1,70	3,30	0,90	LCEX 080409-0180R-R	■					
	1,80	1,70	3,30	0,90	080409-0180L-R	■					
	0,80	2,60	4,00	0,40	LCEX 110504-0080R-R	■					
	0,80	2,60	4,00	0,40	110504-0080L-R	■					
	1,20	2,60	4,00	0,60	LCEX 110506-0120R-R	■					
	1,20	2,60	4,00	0,60	110506-0120L-R	■					
	1,80	2,60	4,00	0,90	LCEX 110509-0180R-R	■					
	1,80	2,60	4,00	0,90	110509-0180L-R	■					
	2,00	2,60	4,00	1,00	LCEX 110510-0200R-R	■					
	2,00	2,60	4,00	1,00	110510-0200L-R	■					
	3,00	2,60	4,00	1,50	LCEX 110515-0300R-R	■					
	3,00	2,60	4,00	1,50	110515-0300L-R	■					

■ Stock standard
 Subject to change refer to current price- and stock-list

Circlip grooves

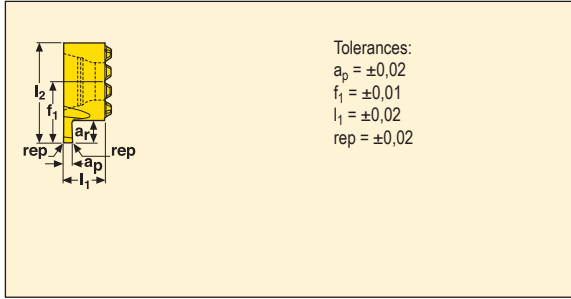

Size	Dimensions in mm	
	l_2	f_1
0804	7,78	4,78
1105	10,70	6,70

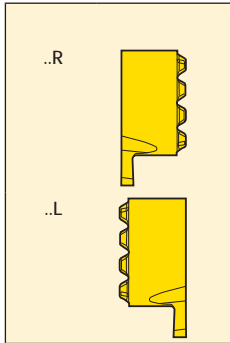

Inserts	For lock ring	Dimensions in mm				Part No.	Grades								
		a_p	a_r	l_1	rep		Coated								
							CP500								
LCEX	0,7	0,75	1,70	3,30	0	LCEX 080400-0075R-FG	■								
	0,7	0,75	1,70	3,30	0	080400-0075L-FG	■								
	0,8	0,85	1,70	3,30	0	LCEX 080400-0085R-FG	■								
	0,8	0,85	1,70	3,30	0	080400-0085L-FG	■								
	0,9	0,95	1,70	3,30	0	LCEX 080400-0095R-FG	■								
	0,9	0,95	1,70	3,30	0	080400-0095L-FG	■								
	1,0	1,15	1,70	3,30	0	LCEX 080400-0115R-FG	■								
	1,0	1,15	1,70	3,30	0	080400-0115L-FG	■								
	1,2	1,35	1,70	3,30	0	LCEX 080400-0135R-FG	■								
	1,2	1,35	1,70	3,30	0	080400-0135L-FG	■								
	1,5	1,65	1,70	3,30	0,10	LCEX 080401-0165R-FG	■								
	1,5	1,65	1,70	3,30	0,10	080401-0165L-FG	■								
	0,7	0,75	2,60	4,00	0	LCEX 110500-0075R-FG	■								
	0,7	0,75	2,60	4,00	0	110500-0075L-FG	■								
	0,8	0,85	2,60	4,00	0	LCEX 110500-0085R-FG	■								
	0,8	0,85	2,60	4,00	0	110500-0085L-FG	■								
	0,9	0,95	2,60	4,00	0	LCEX 110500-0095R-FG	■								
	0,9	0,95	2,60	4,00	0	110500-0095L-FG	■								
	1,0	1,15	2,60	4,00	0	LCEX 110500-0115R-FG	■								
	1,0	1,15	2,60	4,00	0	110500-0115L-FG	■								
	1,2	1,35	2,60	4,00	0	LCEX 110500-0135R-FG	■								
	1,2	1,35	2,60	4,00	0	110500-0135L-FG	■								
	1,5	1,65	2,60	4,00	0,10	LCEX 110501-0165R-FG	■								
	1,5	1,65	2,60	4,00	0,10	110501-0165L-FG	■								

■ Stock standard
 Subject to change refer to current price- and stock-list

Threading – Partial Profile 60°

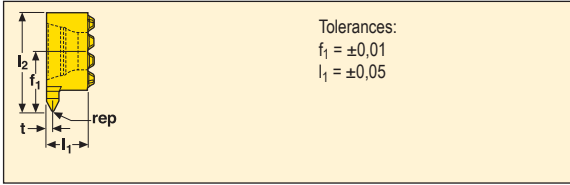

Size	Dimensions in mm		
	f_1	l_1	l_2
0804	4,78	3,30	7,78
1105	6,70	4,00	10,70

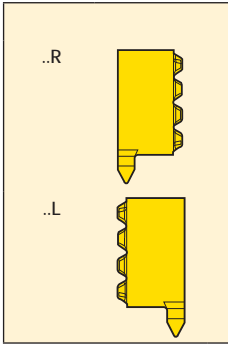

Inserts	Pitch		Dimensions in mm		Part No.	Grades			
	mm	TPI	t	rep		Coated			
						CP500			
LCEX	0,50-0,75	48-36	0,48	0,03	LCEX 0804-A60R	■			
	0,50-0,75	48-36	0,48	0,03	0804-A60L	■			
	0,75-1,25	36-20	0,73	0,07	0804-AG60R	■			
	0,75-1,25	36-20	0,73	0,07	0804-AG60L	■			
	1,25-1,75	20-16	0,98	0,12	0804-G60R	■			
	1,25-1,75	20-16	0,98	0,12	0804-G60L	■			
LCEX	0,50-0,75	48-36	0,48	0,03	LCEX 1105-A60R	■			
	0,50-0,75	48-36	0,48	0,03	1105-A60L	■			
	0,75-1,25	36-20	0,73	0,07	1105-AG60R	■			
	0,75-1,25	36-20	0,73	0,07	1105-AG60L	■			
	1,25-1,75	20-16	0,98	0,12	1105-G60R	■			
	1,25-1,75	20-16	0,98	0,12	1105-G60L	■			

Threading – ISO Metric

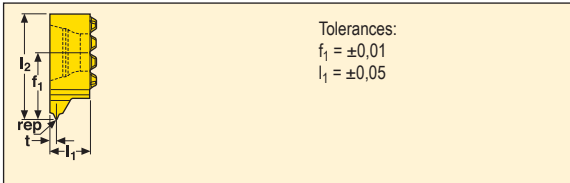

Size	Dimensions in mm		
	f_1	l_1	l_2
1105	6,70	4,00	10,70

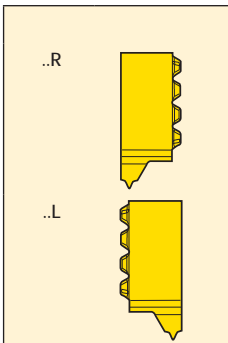

Inserts	Pitch		Dimensions in mm		Part No.	Grades			
	mm	TPI	t	rep		Coated			
						CP500			
LCEX	1,0	–	0,60	0,07	LCEX 1105-1.0ISOR	■			
	1,0	–	0,60	0,07	1105-1.0ISOL	■			
	1,5	–	0,80	0,12	1105-1.5ISOR	■			
	1,5	–	0,80	0,12	1105-1.5ISOL	■			
	2,0	–	1,10	0,17	1105-2.0ISOR	■			
	2,0	–	1,10	0,17	1105-2.0ISOL	■			
	2,5	–	1,35	0,18	1105-2.5ISOR	■			
	2,5	–	1,35	0,18	1105-2.5ISOL	■			
	3,0	–	1,60	0,21	1105-3.0ISOR	■			
	3,0	–	1,60	0,21	1105-3.0ISOL	■			

■ Stock standard

Subject to change refer to current price- and stock-list

Threading – Whitworth, BSW

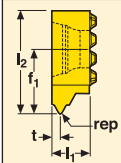

Tolerances:
 $f_1 = \pm 0,01$
 $l_1 = \pm 0,05$

Size	Dimensions in mm		
	f_1	l_1	l_2
1105	6,70	4,00	10,70

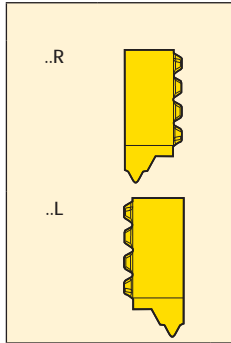

Inserts	Pitch		Dimensions in mm		Part No.	Grades			
	mm	TPI	t	rep		Coated			
						CP500			
LCEX	–	14	1,00	0,24	LCEX 1105-14WR	■			
	–	14	1,00	0,24	1105-14WL	■			
	–	19	0,77	0,15	1105-19WR	■			
	–	19	0,77	0,15	1105-19WL	■			

Threading – TR-DIN103

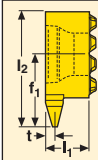

Tolerances:
 $f_1 = \pm 0,01$
 $l_1 = \pm 0,05$

Size	Dimensions in mm		
	f_1	l_1	l_2
1105	6,70	4,00	10,70

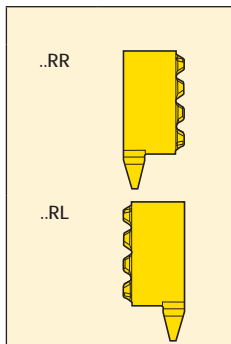

Inserts	Pitch		Dimensions in mm		Part No.	Grades			
	mm	TPI	t	rep		Coated			
						CP500			
LCEX	1,5	–	0,80	0,10	LCEX 1105-1.5TRR	■			
	1,5	–	0,80	0,10	1105-1.5TRL	■			
	2,0	–	1,10	0,15	1105-2.0TRR	■			
	2,0	–	1,10	0,15	1105-2.0TRL	■			
	3,0	–	1,60	0,15	1105-3.0TRR	■			
	3,0	–	1,60	0,15	1105-3.0TRL	■			

■ Stock standard

Subject to change refer to current price- and stock-list

Toolholders





C	E	R	25	25	M	14	Q	HD
1	2	3	4	5	6	7	8	9

<p>1. Insert clamping</p> <p>C</p> <p>Clamp</p>	<p>2. External/Internal</p> <p>E = External</p> <p>N = Internal</p> <p>EA = External axial</p>	<p>3. Version</p> <p>L</p> <p>R</p> <p>X = Special</p>
<p>4. Shank height</p> <p>h</p> <p>12 = 12 mm 16 = 16 mm 20 = 20 mm etc</p>	<p>5. Shank width/diameter</p> <p>b</p> <p>d</p> <p>12 = 12 mm 16 = 16 mm 20 = 20 mm etc</p>	<p>6. Tool length</p> <p>l₁</p> <p>H = 100 mm H = 100 mm K = 125 mm K = 125 mm M = 150 mm M = 150 mm P = 170 mm P = 170 mm R = 200 mm R = 200 mm</p>
<p>7. Cutting edge length</p> <p>If the cutting edge length consists of only one digit, the designation should start with a 0.</p> <p>Example: Cutting edge length = 9,525 mm Symbol = 09</p>	<p>8. Other information</p> <p>A = Steel with coolant passage DF = Holder for deep grooving Q = Toolholder/cranked</p>	<p>9. Internal designation</p> <p>HD = Heavy Duty</p>

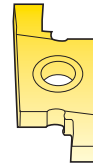
Inserts

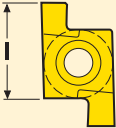

14	E	R	3.4	FG
1	2	3	4	5

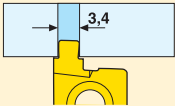
<p>1. Cutting edge length</p>  <p>If the cutting edge length consists of only one digit, the designation should start with a 0.</p> <p>Example: Cutting edge length = 9,525 mm Symbol = 09</p>	<p>2. External/Internal</p> <p>E = External N = Internal EA = External axial</p>	<p>3. Version</p> <p>L</p>  <p>R</p> 
<p>4. Groove width</p>  <p>Example: 3.4 = 3,4 mm</p>	<p>5. Standard groove</p> <p>Standard grooves=</p> <p>FG = Radial groove ($a_p \times 1$) FD = Radial deep groove ($a_p \times 2$) D76 = Thread undercut R = Round ST = O-ring, static DY = O-ring, dynamic AX = O-ring, axial FA = Axial groove ($a_p \times 1$)</p>	

Grooving – Precision grooves, depth/width ratio 1:1 (2:1)

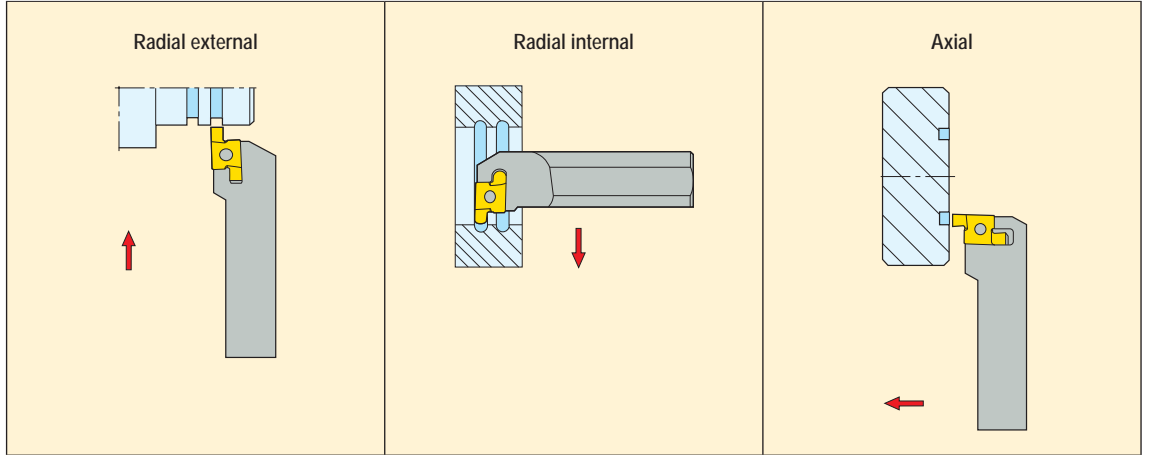

Toolholders

The toolholder system is based on the Snap Tap threading system. The toolholders have replaceable shims designed to protect the insert seat.

The system is intended for radial external and internal grooving and for axial grooving. The system enables axial grooves from 16 mm outside diameter and internal radial grooves down to 13 mm diameter to be turned.

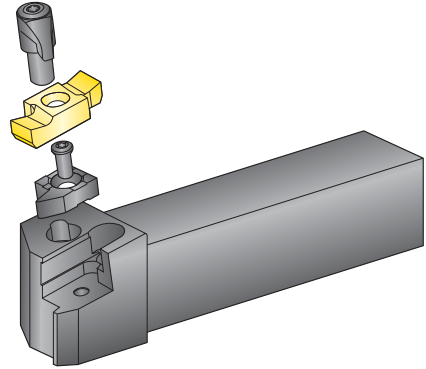

Inserts

The range of grooving inserts includes inserts for most groove profiles, such as circlip profiles, O-ring profiles, thread undercut and radius grooves. The range of grooving inserts can be used for grooves with a depth/width ratio of up to 1:1.

Inserts with designation FD can be used for grooves with a depth/width ratio of up to 2:1.

Lockring

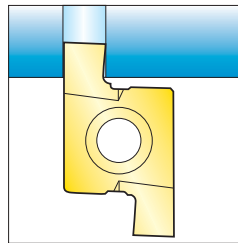

O-ring

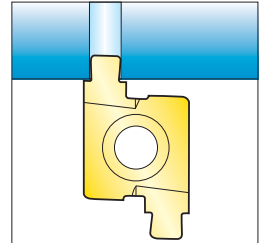

Thread undercut

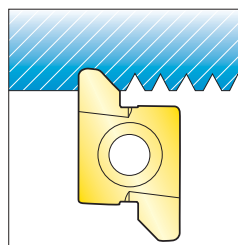

Radius

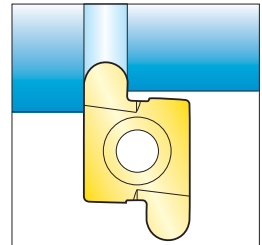

Grades

Grades	P					M					K					N				S				H				
	P01	P10	P20	P30	P40	P50	M01	M10	M20	M30	M40	K01	K10	K20	K30	K40	N01	N10	N20	N30	S01	S10	S20	S30	H01	H10	H20	H30
CP30																												
CP500																												

CP30

Wear resistant CVD-coated grade intended for grooving in a variety of workpiece materials. Provides good wear resistance and cutting speed capability in steel and cast iron.

CP500

Tough versatile PVD-coated micrograin grade intended for grooving in a variety of workpiece materials. Universal choice.

Ordering specification for custom made K-inserts

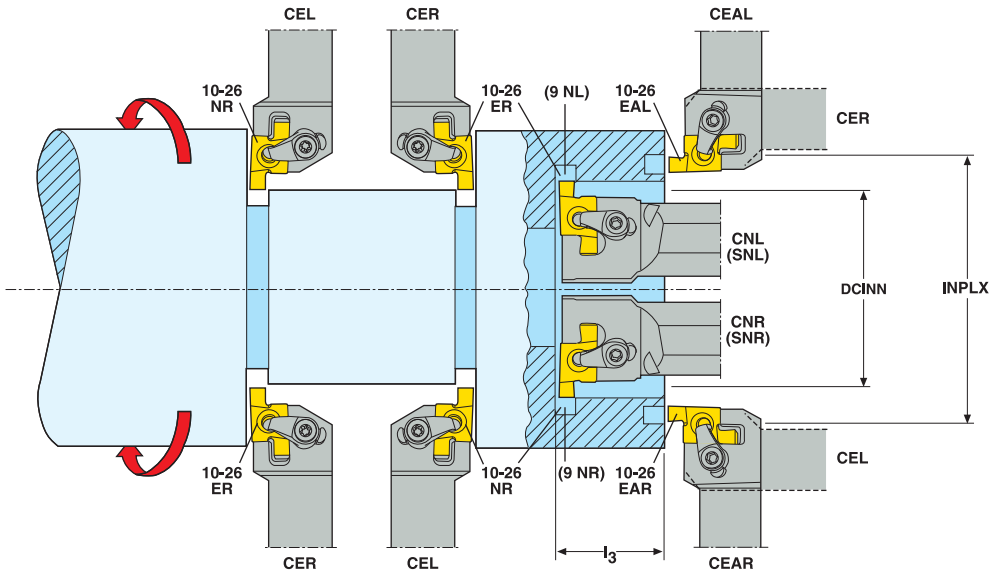

Internal grooving:

When considering operation NR and NL illustrated above (holder CNR and CNL), always state the diameter of the hole as well as the axial position of the groove = l_3 . In the case of small hole diameters, however, use holder SNR and SNL with insert 9NR and 9NL respectively.

Axial grooving:

With operation type EAR and EAL (holder CEAR and CEAL) the outer dimension of the groove (INPLX) must be stated.

Set-up machining recommendations

Set-up

- The mounting should be stable.
- The tool should be securely clamped and the overhang should be as small as possible.
- The centre height should never deviate by more than $\pm 0,1$ mm from the workpiece centre.

Internal grooving

- Decisive factors for ensuring vibration-free machining are the relationship between the toolholder overhang and its diameter, and the width of the grooving insert.
- In unfavourable circumstances, the cutting speed and feed rate should be reduced below the recommended values.

Grooving of radius grooves and grooves with trapezoidal cross-section

- In this type of grooving, different forms of chip problems often occur. The feed rate should therefore be reduced to obtain thin chips and avoid chip build-up and insert fracture.

Formulae for cutting data calculation are found in page(s) 47.

Special inserts for precision grooves

- Ground to specification using the insert blanks shown.
- Blanks available for grade CP30 and CP500.
- Please contact your local representative for price and delivery.

Tolerances for different groove profiles:

Tolerances				
a_r	a_p	rep	r	v°
$\pm 0,025$	$\pm 0,025$	$\pm 0,03$	$\pm 0,03$	$\pm 15'$

Inserts	Dimensions				Shim	Inserts
	l	d	a_p	a_r	Standard KX	
	9,0	6,350	2,7	2,70	–	9NR/NL
	9,0	6,350	2,7	2,70	KX10	10ER/NR 10EAR/EAL
	12,0	6,350	2,7	5,65	KX12	12ER/NR 12EAR/EAL
	14,0	9,525	4,2	4,40	KX14	14ER/NR 14EAR/EAL
	20,0	12,700	6,3	7,30	KX20	20ER/NR 20EAR/EAL
	26,0	15,875	10,0	10,10	KX26	26ER/NR 26EAR/EAL

Cutting speed, v_c (m/min)

In this section a recommended cutting speed is indicated under specified conditions.

Use the tables beginning on page(s) 688 to classify the workpiece material into a SMG

The cutting data tables provide a start value for feed rate (f) and cutting speed (v_c) for the selected cutting width (a_p).

The cutting data tables are based on grooving with full cutting width.

The recommended cutting speeds in the tables are calculated for 15 minutes tool life with use of external flood coolant.

In order to increase the accuracy towards the actual cutting conditions and requirements of the applications the recommendation is to use My Pages – Suggest on www.secotools.com

v_c = cutting speed (m/min)

a_p = insert width (mm)

f = feed rate (mm/rev)

CP30

SMG		$a_p = 0.5-2.0$		$a_p = 2.0-4.0$		$a_p = 4.0-6.0$		$a_p = 6.0-8.0$		$a_p = 8.0-10.0$	
		f	v_c	f	v_c	f	v_c	f	v_c	f	v_c
P1	CP30	0,095	190	0,15	165	0,17	155	0,20	145	0,22	140
P2	CP30	0,10	185	0,16	155	0,17	150	0,20	140	0,22	135
P3	CP30	0,095	160	0,15	135	0,17	130	0,19	125	0,20	120
P4	CP30	0,090	145	0,14	125	0,16	120	0,19	110	0,20	110
P5	CP30	0,090	135	0,14	120	0,16	110	0,18	105	0,20	105
P6	CP30	0,090	155	0,14	130	0,16	125	0,18	120	0,20	115
P7	CP30	0,090	145	0,14	125	0,16	120	0,18	115	0,20	110
P8	CP30	0,095	135	0,15	115	0,17	110	0,19	105	0,20	105
P11	CP30	0,090	140	0,14	120	0,16	115	0,18	110	0,20	105
M1	CP30	0,10	215	0,16	160	0,17	150	0,20	130	0,22	115
M2	CP30	0,090	180	0,14	140	0,16	130	0,18	115	0,20	105
M3	CP30	0,070	145	0,11	125	0,13	115	0,15	100	0,16	95
M4	CP30	0,065	110	0,10	100	0,11	95	0,13	85	0,14	80
M5	CP30	0,065	95	0,10	80	0,11	80	0,13	70	0,14	65

CP500

SMG		$a_p = 0.5-2.0$		$a_p = 2.0-4.0$		$a_p = 4.0-6.0$		$a_p = 6.0-8.0$		$a_p = 8.0-10.0$	
		f	v_c	f	v_c	f	v_c	f	v_c	f	v_c
P1	CP500	0,095	145	0,15	125	0,17	120	0,20	110	0,22	105
P2	CP500	0,10	140	0,16	120	0,17	115	0,20	110	0,22	105
P3	CP500	0,095	125	0,15	105	0,17	100	0,19	95	0,20	95
P4	CP500	0,090	110	0,14	95	0,16	90	0,19	85	0,20	80
P5	CP500	0,090	105	0,14	90	0,16	85	0,18	80	0,20	80
P6	CP500	0,090	120	0,14	100	0,16	95	0,18	90	0,20	90
P7	CP500	0,090	110	0,14	95	0,16	90	0,18	85	0,20	85
P8	CP500	0,095	105	0,15	90	0,17	85	0,19	80	0,20	80
P11	CP500	0,090	110	0,14	95	0,16	90	0,18	85	0,20	80
M1	CP500	0,10	165	0,16	120	0,17	115	0,20	100	0,22	90
M2	CP500	0,090	140	0,14	110	0,16	100	0,18	90	0,20	80
M3	CP500	0,070	115	0,11	95	0,13	85	0,15	80	0,16	75
M4	CP500	0,065	85	0,10	75	0,11	70	0,13	65	0,14	60
M5	CP500	0,065	70	0,10	65	0,11	60	0,13	55	0,14	50
K1	CP500	0,10	125	0,16	105	0,17	105	0,20	100	0,22	95
K2	CP500	0,090	115	0,14	95	0,16	85	0,18	80	0,20	75
K3	CP500	0,090	95	0,14	80	0,16	75	0,18	70	0,20	65
K4	CP500	0,090	90	0,14	75	0,16	70	0,18	65	0,20	60
K5	CP500	0,080	55	0,13	46	0,14	45	0,16	42	0,18	39
K6	CP500	0,090	80	0,14	70	0,16	65	0,18	65	0,20	60
K7	CP500	0,080	75	0,13	60	0,14	55	0,16	55	0,18	50
N11	CP500	0,13	85	0,20	70	0,22	70	0,26	65	0,28	60
S1	CP500	0,065	18	0,10	16	0,11	15	0,13	14	0,14	14
S2	CP500	0,065	16	0,10	14	0,11	13	0,13	13	0,14	12
S3	CP500	0,060	14	0,090	12	0,10	12	0,12	11	0,13	11

Toolholders for Shallow Grooves

Snap-Tap



• For insert programme, see page(s) 624, 626-629, 631

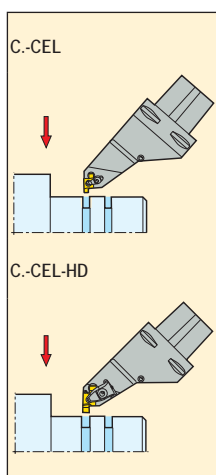
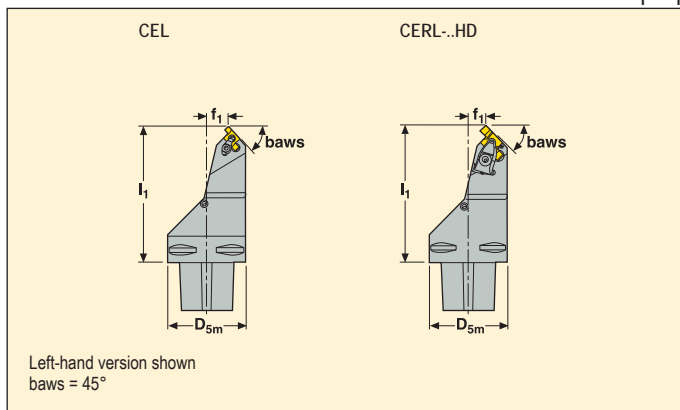

Capto size	Part No.	Dimensions in mm			KG	Icon
		D _{sm}	f ₁	l ₁		
C6	10/12 C6-CEL-20110-10	63	20	110	1,6	10.. / 12..
	14 C6-CEL-18110-14	63	18	110	1,7	14..
	20 C6-CEL-14110-20HD	63	14	110	1,7	20..
	26 C6-CEL-07110-26HD	63	7	110	1,7	26..

Spare Parts, Parts included in delivery

For holder	Cantilever clamp	Clamp key	Clamp kit	Clamp screw	Insert shim (K)	Shim screw	Spring
-10	–	T15P-2	CSP16-T15P	–	KX10-2	CS2507-T07P	–
-14	–	T15P-2	CSP16-T15P	–	KX14-2	CS3507-T09P	–
-20HD	CHD22	T20P-7	–	L86025-T20P	KX20-2	CS4009-T15P	S7616
-26HD	CHD27	T20P-7	–	L86025-T20P	KX26-2	C05012-T15P	S7616

Accessories*

Insert shim	Shim key
KX12-2	T07P-2
	T09P-2
	T15P-2
	T15P-2

Please check availability in current price and stock-list

*To be ordered separately
**Shim KX12-2 for insert 12..., to be ordered separately

Toolholders for Precision Grooves

Snap-Tap

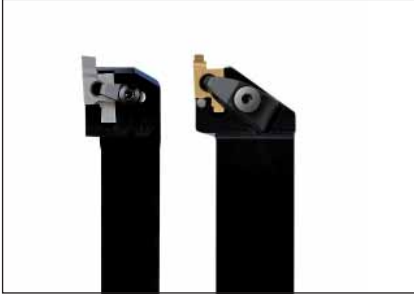

• For insert programme, see page(s) 624, 626-629, 631

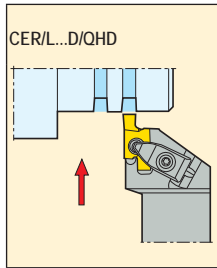
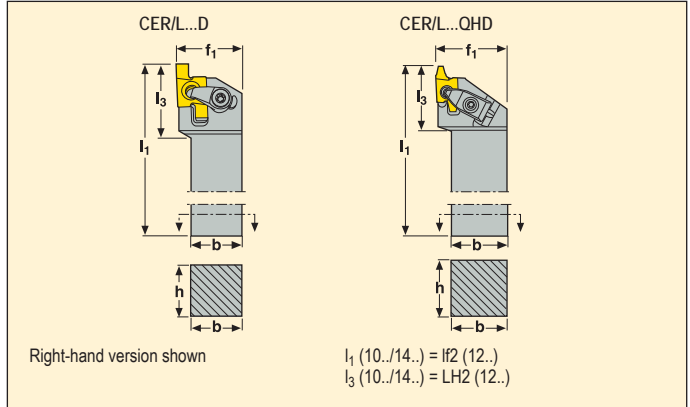

	Part No.	Dimensions in mm							KG	
		h	b	l ₁ 10../14..	lf2 12..	f ₁	l ₃ 10../14..	LH2 12..		
10/12	CER 1212M10D	12	12	150	153	16	22	24.5	0.2	10../ 12..
	1616H10D	16	16	100	103	16	22	24.5	0.2	10../ 12..
	2020K10D	20	20	125	128	25	22	24.5	0.4	10../ 12..
	2525M10D	25	25	150	153	32	22	24.5	0.8	10../ 12..
	3225P10D	32	25	170	173	32	23	25.5	1.1	10../ 12..
	CEL 1212M10D	12	12	150	153	16	22	24.5	0.2	10../ 12..
	1616H10D	16	16	100	103	16	22	24.5	0.2	10../ 12..
	2020K10D	20	20	125	128	25	22	24.5	0.4	10../ 12..
	2525M10D	25	25	150	153	32	22	24.5	0.8	10../ 12..
3225P10D	32	25	170	173	32	23	25.5	1.1	10../ 12..	
14	CER 2525M14QHD	25	25	150	–	32	26	–	0.8	14..
	3225P14QHD	32	25	170	–	32	26	–	1.1	14..
	3232P14QHD	32	25	170	–	32	26	–	1.4	14..
	CEL 2525M14QHD	25	25	150	–	32	26	–	0.8	14..

Spare Parts, Parts included in delivery

Accessories*

For holder	Cantilever clamp	Clamp key	Clamp kit	Clamp screw	Insert shim (K)	Shim screw	Spring	Insert shim	Shim key
..10D	–	T15P-2	CSP16-T15P	–	KX10-2	CS2507-T07P	–	KX12-2	T07P-2
..14QHD	CHD16	T15P-2	–	L85020-T15P	KX14-2	CS3507-T09P	S6912	–	T09P-2

Please check availability in current price and stock-list

*To be ordered separately
**Shim KX12-2 for insert 12.., to be ordered separately

Toolholders for Precision Grooves

Snap-Tap



• For insert programme, see page(s) 624, 626-629, 631

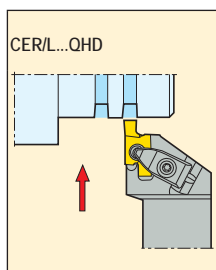
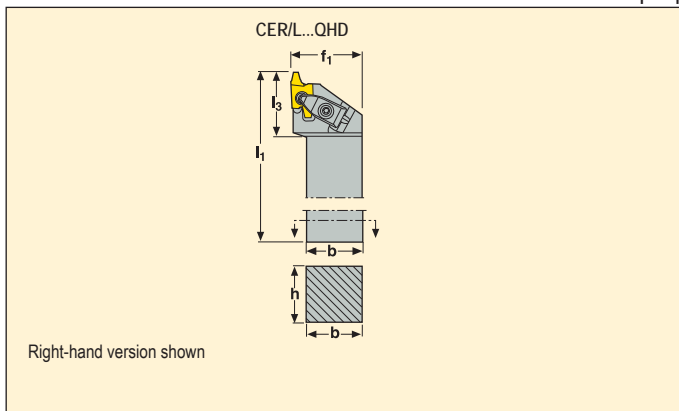

	Part No.	Dimensions in mm					KG	
		h	b	l ₁	f ₁	l ₃		
20	CER 2525M20QHD	25	25	150	32	34	0,8	20..
	3225P20QHD	32	25	170	32	34	1,1	20..
	3232P20QHD	32	32	170	40	34	1,4	20..
	CEL 2525M20QHD	25	25	150	32	34	0,8	20..
	3225P20QHD	32	25	170	32	34	1,1	20..
	3232P20QHD	32	32	170	40	34	1,4	20..
26	CER 2525M26QHD	25	25	150	40	44	0,9	26..
	3225P26QHD	32	25	170	40	44	1,2	26..
	3232P26QHD	32	32	170	40	44	1,4	26..
	CEL 2525M26QHD	25	25	150	40	44	0,9	26..
	3225P26QHD	32	25	170	40	44	1,2	26..
	3232P26QHD	32	32	170	40	44	1,4	26..

Spare Parts, Parts included in delivery

Accessories*

For holder	Cantilever clamp	Clamp key	Clamp screw	Insert shim (K)	Shim screw	Spring	Shim key	
..20QHD	CHD22	T20P-7	L86025-T20P	KX20-2	CS4009-T15P	S7616	T15P-2	
..26QHD	CHD27	T20P-7	L86025-T20P	KX26-2	C05012-T15P	S7616	T15P-2	

Please check availability in current price and stock-list

*To be ordered separately

Toolholders for Precision Grooves

Snap-Tap

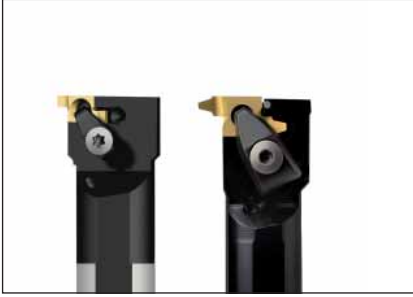

• For insert programme, see page(s) 624, 626-629, 631

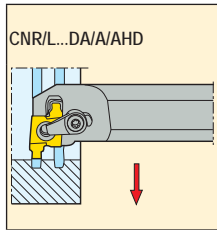
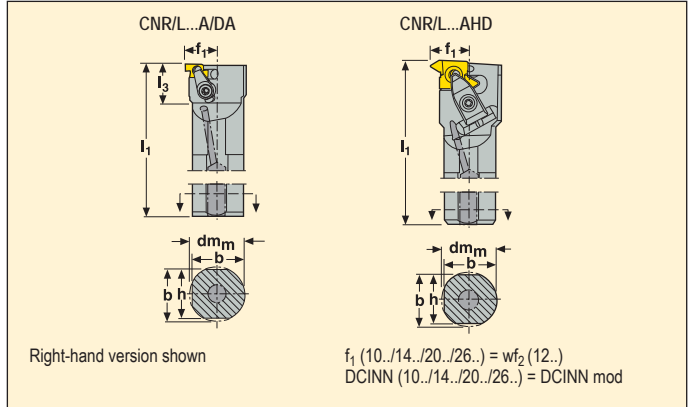

Part No.	Dimensions in mm										KG	
	dm _m	h	b	l ₁	f ₁	wf ₂ 12..	l ₃	DCINN*	DCINN* mod			
10/12	CNR 0020P10DA	20	18	19	170	13,5	16,5	26	26	29	0,4	10../12..
	0025R10DA	25	23	24	200	16,0	19,0	28	31	34	0,7	10../12..
	0032S10DA	32	30	31	250	19,5	22,5	31	38	41	1,4	10../12..
	CNL 0020P10DA	20	18	19	170	13,5	16,5	26	26	29	0,4	10../12..
	0025R10DA	25	23	24	200	16,0	19,0	28	31	34	0,7	10../12..
	0032S10DA	32	30	31	250	19,5	22,5	31	38	41	1,4	10../12..
14	CNR 0020P14A	20	18	19	170	15,0	–	32	30	–	0,4	14..
	0025R14A	25	23	24	200	17,5	–	45	34	–	0,7	14..
	0032S14A	32	30	31	250	21,0	–	48	40	–	1,4	14..
	0040T14A	40	37	39	300	25,0	–	50	48	–	2,6	14..
	CNL 0020P14A	20	18	19	170	15,0	–	32	30	–	0,4	14..
	0025R14A	25	23	24	200	17,5	–	45	34	–	0,7	14..
20	0032S14A	32	30	31	250	21,0	–	48	40	–	1,4	14..
	CNR 0025R20AHD	25	23	24	200	20,5	–	50	38	–	0,7	20..
	0032S20AHD	32	30	31	250	24,0	–	50	44	38	1,5	20..
	0040T20AHD	40	37	39	300	28,0	–	50	51	40	2,6	20..
	CNL 0025R20AHD	25	23	24	200	20,5	–	50	38	–	0,7	20..
26	0032S20AHD	32	30	31	250	24,0	–	50	44	38	1,4	20..
	CNR 0032S26AHD	32	30	31	250	27,0	–	61	50	50	1,5	26..
	0040T26AHD	40	37	39	300	31,0	–	60	55	50	2,6	26..
	0050U26AHD	50	47	49	350	36,0	–	62	65	–	4,8	26..
	0063V26AHD	63	60	62	400	42,5	–	64	80	63	8,9	26..
CNL 0040T26AHD	40	37	39	300	31,0	–	60	55	50	2,6	26..	

*DCINN – minimum bore diameter, see page 614

Spare Parts, Parts included in delivery

Accessories*

For holder	Cantilever clamp	Clamp key	Clamp kit	Clamp screw	Insert shim (K)	Shim screw	Spring	Insert shim	Shim key
..10	–	T15P-2	CSP16-T15P	–	KX10-2	CS2507-T07P	–	KX12-2	T07P-2
..14	–	T15P-2	CSP16-T15P	–	KX14-2	CS3507-T09P	–	–	T09P-2
..20	CHD22	T20P-7L	–	L86025-T20P	KX20-2	CS4009-T15P	S7616	–	T15P-2
..26	CHD27	T20P-7L	–	L86025-T20P	KX26-2	C05012-T15P	S7616	–	T15P-2

Please check availability in current price and stock-list

*To be ordered separately

**Shim KX12-2 for insert 12.., to be ordered separately

Inserts – Precision Grooves, O-ring Static

Tolerances:
 $a_p = +0,07/-0,03$
 $RETR/RETL = \pm 0,05$
 $rep = \pm 0,15$
 $a_r = \pm 0,025$
 Toolholder range, see page(s) 618-619, 621-622

Size	Dimensions in mm							
	a_p	t	W	l	RETR	RETL	rep	a_r
14..1.6	2,40	2,0	9,525	14	0,20	0,20	0,50	1,110
14..2.4	3,20	2,0	9,525	14	0,23	0,23	0,50	1,780
20..3.0	3,80	3,2	12,700	20	0,30	0,30	1,00	2,250
20..3.55	5,10	3,2	12,700	20	0,40	0,40	1,00	3,190
20..4.1	6,50	5,0	15,875	26	0,40	0,40	1,00	4,560
26..5.7	4,80	3,2	12,700	20	0,30	0,30	0,75	2,640

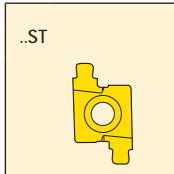

For O-ring		Standard	Part No. External right Internal left	Grades			Part No. Internal right External left	Grades		
mm	inch			Coated				Coated		
				CP30	CP500			CP30	CP500	
1,60	–	*	14ER 1.6ST	■		14NR 1.6ST	■			
2,40	–	*	2.4ST	■						
3,00	–	*	20ER 3.0ST	■		20NR 3.0ST	■			
4,10	–	*	4.1ST	■						
5,70	–	*	26ER 5.7ST	■		26NR 5.7ST	■			
3,55	0.140	**	20ER 3.55ST	■						

Standard
 * =
 SMS 1588
 BS 4518

** =
 ISO 3601
 DIN 3771
 BS 1806

■ Stock standard
 Subject to change refer to current price- and stock-list

LPGN

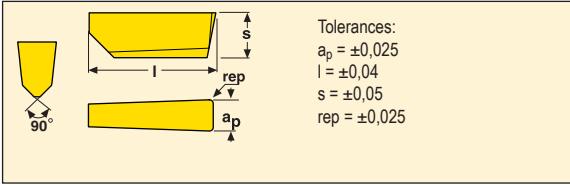

Size	Dimensions in mm			
	a_p	l	s	rep
1204	3,175	12,70	4,50	0,381
1906	6,350	19,05	6,10	0,381
2508	7,925	25,40	8,31	0,787

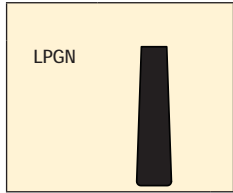

Inserts	Part No.	Grades				
		Uncoated				
LPGN		CW100				
LPGN	120404-03175E	■				
LPGN	190608-0635E	■				
LPGN	250808-07925E	■				

LPGN

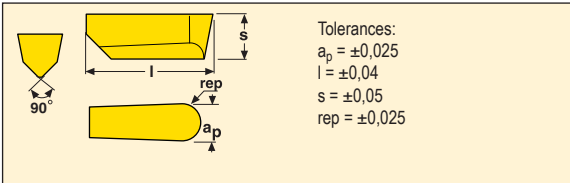

Size	Dimensions in mm			
	a_p	l	s	rep
1906	6,350	19,05	6,10	3,175



Inserts	Part No.	Grades				
		Uncoated				
LPGN...M0		CW100				
LPGN...M0	1906M0-0635E	■				

■ Stock standard
 Subject to change refer to current price- and stock-list

Tip sizes, see page(s) 70
 Edge preparation, see page(s) 67

Parting-off

Toolholders

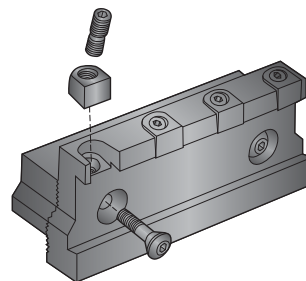
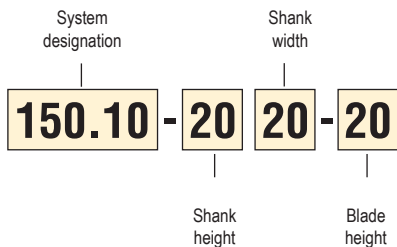

Blades

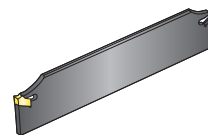
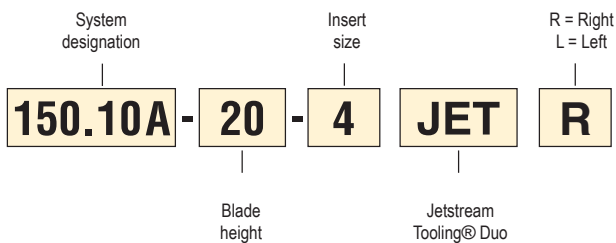

Inserts

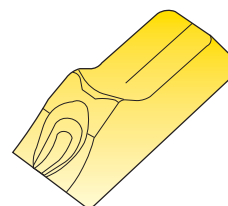
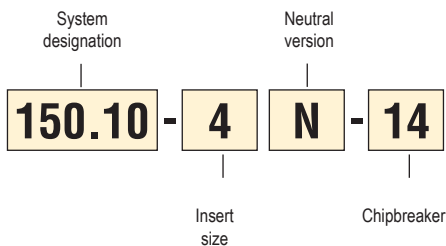

For more information on Jetstream Tooling® and accessories, please see page(s) 27, 684.

Parting-off, up to Ø160 mm

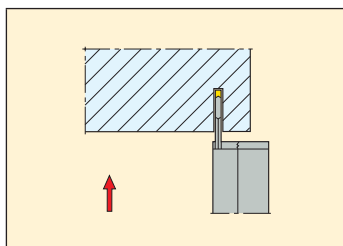

General

- Use the highest blade possible (size 25) for maximum stability.
- Use the shortest overhang possible for maximum stability and low risk of vibrations.
- Make sure that the tool is at 90° to the centre-line of the component to ensure part quality and good tool life.
- Ideally, parting-off is run with a sub-spindle or part-catcher. In this case the cutting edge will be protected by having the second spindle or a fixture picking up the workpiece.
- Parting-off without sub-spindle requires the feed rate to be reduced as the tool approaches centre (by up to 75% about 2 mm before the component centre – depending on workpiece diameter). May also be applied on tubes to reduce burr.
- A well-aimed and sufficient flow of coolant, ideally through the blades 150.10JET, will give long tool life and good surface finish.
- Smaller inserts reduce the material waste and thus reduce material cost. On the other hand wider inserts allow higher feed rates, which increases productivity. The optimum depends on the customer preference and priority.

Seco Jetstream Tooling® Duo holders, yet another innovation introduced to market, feature both a rake face and flank face jet, that may provide even better chip control and significantly longer tool life.



Toolholders

The Seco 150.10A parting-off system consists of a high speed steel blade which holds the insert and a holder which retains the blade. This provides maximum stability, while the hot strength of the high speed steel ensures that the insert will be securely retained even when the blade is hot.

Type 150.10..-20/25 basic holder

Intended for long, reversible high speed steel blades with a depth of cut of up to 160 mm diameter. The two-part toolholder facilitates clamping in machines with front clamping. The same holder is suitable for both right-hand and left-hand versions, since the blade can be positioned to the required length in either direction.

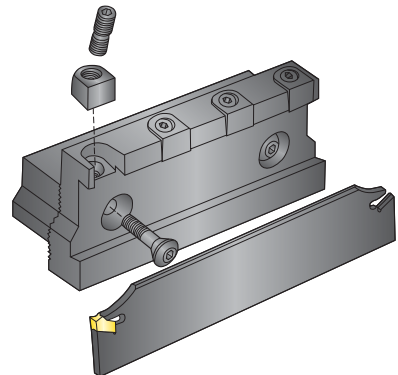

Type 150.10..-15 blade holder

Intended for short high speed steel blades for cutting depths up to 38 mm diameter. The high speed steel blade ensures excellent stability and, due to the compact design, is suitable for machines with limited space, such as automatic lathes.

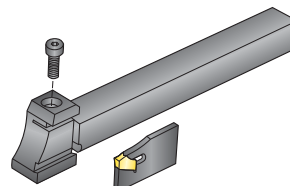

Inserts N-/ R- /L-

- Inserts in neutral version N are first choice since they normally achieve increased tool life, better chip control, high surface quality and allow higher cutting data compared to the handed (R-/L-) version.
- The R-/L-inserts have a setting angle of 6° in order to eliminate burrs and minimize the parting-off pip left on the workpiece. To reduce pip size with N-inserts, use the smallest width possible. The correct centre height is another major factor to avoid pips (control to ± 0.1 mm).
- When using R-/L-inserts, the feed rate should be reduced by approximately 30%.
- Convex or concave surfaces will be avoided, when using right or left hand inserts, by reducing the feed rate.

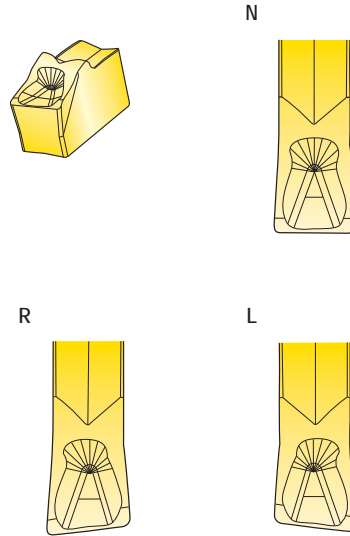

Chipbreakers

-12



- First choice for steel at low feed rates.
- 24° positive cutting rake angle.
- Excellent chipbreaking.

-14



- First choice for stainless steel.
- First choice for steel at medium-high feed rates.
- 15° positive cutting rake angle with sharp edge.

-16



- First choice for steel and cast iron in difficult conditions and/or high feed rates.
- 20° positive cutting rake angle.
- Strong protection chamfer.

Recommended feed rates

Insert width a_p (mm)	Chip-breaker	Radial infeed, f (mm/rev)					
		Type N insert			Type R/L insert		
		Recom. initial value	Recom. limit value		Recom. initial value	Recom. limit value	
			min	– max		min	– max
1,40	-12	–	–	–	–	–	–
	-14	0,05	0,04	0,12	–	–	–
	-16	0,06	0,04	0,12	–	–	–
2,0	-12	–	–	–	–	–	–
	-14	0,07	0,05	0,14	–	–	–
	-16	0,08	0,05	0,15	–	–	–
2,25	-12	–	–	–	–	–	–
	-14	0,09	0,05	0,16	–	–	–
	-16	0,10	0,05	0,20	–	–	–
2,5	-12	0,09	0,05	0,18	0,06	0,04	0,13
	-14	0,10	0,07	0,20	0,07	0,05	0,14
	-16	0,13	0,10	0,24	0,09	0,07	0,17
3,1	-12	0,10	0,05	0,20	0,07	0,04	0,14
	-14	0,13	0,08	0,24	0,09	0,06	0,17
	-16	0,18	0,12	0,28	0,13	0,08	0,20
4,1	-12	0,13	0,07	0,22	0,09	0,05	0,15
	-14	0,15	0,09	0,26	0,11	0,06	0,18
	-16	0,20	0,14	0,32	0,14	0,10	0,22
5,1	-12	0,15	0,08	0,26	0,11	0,06	0,18
	-14	0,18	0,10	0,34	0,13	0,07	0,24
	-16	0,23	0,16	0,40	0,16	0,11	0,28
6,3	-12	0,17	0,10	0,30	0,12	0,07	0,21
	-14	0,20	0,14	0,38	0,14	0,10	0,27
	-16	0,25	0,18	0,42	0,18	0,13	0,29

Grades

The chart below shows application areas for grades available in the Parting-off system 150.10.

The black areas in the chart indicate a grade's main ISO application groups and the white areas indicate other supplementary application groups.

ISO classification of the grades

Grades	Steel					Stainless steel				Cast iron				Non-ferrous metals				Superalloys and titanium				Hard materials						
	P					M				K				N				S				H						
	P01	P10	P20	P30	P40	P50	M01	M10	M20	M30	M40	K01	K10	K20	K30	K40	N01	N10	N20	N30	S01	S10	S20	S30	H01	H10	H20	H30
TGP35			●					○						○														
TGP45		●	●	●	●			○	○					○														
T25M			●	●	●			○	○					○														
T350M			●	●	●			○	○					○								●	●	●				
CP500			●	●	●			○	○					○								●	●	●				
CP600			○					○	○					○	○							○	○	○				
HX								○						○				○										

TGP35

Wear-resistant Duratomic® CVD-coated grade intended for parting-off of steel and cast iron at high cutting speeds.

TGP45

Wear-resistant Duratomic® CVD-coated grade intended for parting-off of steel and stainless steel at moderate to high cutting speeds.

T25M

Tough versatile CVD-coated grade intended for parting-off of steel, stainless steel and cast iron at moderate cutting speeds.

T350M

Tough versatile CVD-coated grade intended for parting-off in a variety of workpiece materials at moderate cutting speeds.

CP500

Tough, versatile PVD-coated micrograin grade intended for parting-off of steel, stainless steel, superalloys and titanium at low to moderate cutting speeds. First choice in stainless steel. Provides more wear resistance compared to CP600

CP600

Very tough PVD-coated fine-grain grade intended for parting-off of steel, stainless steel, superalloys and titanium at low cutting speeds. Well-suited in interrupted cuts. Universal choice.

HX

Uncoated wear resistant hard grade intended for parting-off of hardened steels, superalloys, titanium alloys and non-ferrous materials.

Parting-off – Secolor

To centre

Easy conditions Difficult conditions

12 CP500	16 CP600
14 CP500	16 CP600
12 TGP35	16 T25M
14 CP500	16 CP600
16 HX	14 CP600
16 HX	16 T350M





Easy conditions: pre-machined surface, small diameter, thin walls etc.
Difficult conditions: raw surface, large diameter, thick walls etc.

Tube

Easy conditions Difficult conditions

16 TGP45	16 CP600
14 CP500	16 CP600
12 TGP35	16 TGP45
14 CP500	16 CP600
16 HX	16 CP600
16 HX	16 T350M

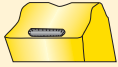
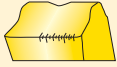
Troubleshooting

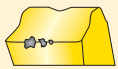
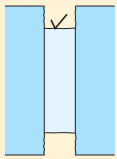
<p>Flank wear</p> 	<ul style="list-style-type: none"> • Reduce the cutting speed. • Select a more wear resistant grade. 	<p>Insert fracture</p> 	<ul style="list-style-type: none"> • Reduce the feed rate. • Select a tougher grade. • Select a stronger chipbreaker.
<p>Crater wear</p> 	<ul style="list-style-type: none"> • Use a coolant. • Select a more wear resistant grade. • Reduce the cutting speed. • Reduce the feed rate. 	<p>Comb cracks</p> 	<ul style="list-style-type: none"> • Reduce the cutting speed. • Reduce the feed rate. • Ensure that the coolant flow is adequate and constant. If not, shut off the coolant.
<p>Plastic deformation</p> 	<ul style="list-style-type: none"> • Use a coolant. • Select a more wear resistant grade. • Reduce the cutting speed. • Reduce the feed rate. 	<p>Built-up edge</p> 	<ul style="list-style-type: none"> • Increase the cutting speed. • Increase the feed rate. • Do not use coolant.
<p>Edge chipping</p> 	<ul style="list-style-type: none"> • Select a tougher grade. • Check the workpiece mounting. • Check the cutting speed. 	<p>Poor finish</p> 	<ul style="list-style-type: none"> • Reduce the feed rate. • Increase the cutting speed. • Use a coolant. • Improve the stability. • Check the alignment of the tool.

Change of insert

Inserts are changed with the aid of key 150.10A-150.

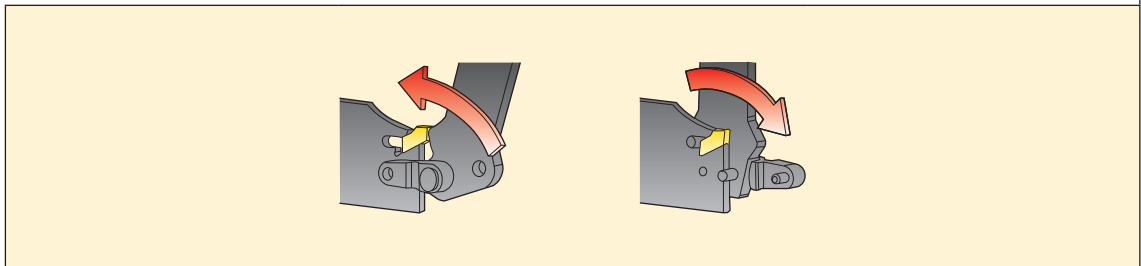

Cutting speed, v_c (m/min)

In this section a recommended cutting speed is indicated under specified conditions.

Use the tables beginning on page(s) 688 to classify the workpiece material into a SMG.

The cutting data tables provide a recommendation of chipbreaker and a start value for feed rate (f) and cutting speed (v_c) for selected cutting width (a_p).

The recommended cutting speeds in the tables are calculated for 15 minutes tool life with use of external flood coolant.

In order to increase the accuracy towards the actual cutting conditions and requirements of the applications the recommendation is to use My Pages – Suggest on www.secotools.com

v_c = cutting speed (m/min)

a_p = insert width (mm)

f = feed rate (mm/rev)

TGP35

SMG		$a_p = 2.5$		$a_p = 3$		$a_p = 4$		$a_p = 5-6$	
		f	v_c	f	v_c	f	v_c	f	v_c
P1	-16 TGP35	0,14	310	0,19	265	0,22	235	0,28	190
P2	-16 TGP35	0,14	305	0,20	250	0,22	230	0,28	185
P3	-16 TGP35	0,14	260	0,19	220	0,22	200	0,26	170
P4	-16 TGP35	0,13	235	0,18	200	0,20	185	0,26	150
P5	-16 TGP35	0,13	225	0,18	190	0,20	180	0,26	140
P6	-16 TGP35	0,13	255	0,18	215	0,20	200	0,26	160
P7	-16 TGP35	0,13	240	0,18	205	0,20	190	0,26	150
P8	-16 TGP35	0,14	220	0,19	185	0,22	165	0,26	140
P11	-16 TGP35	0,13	230	0,18	200	0,20	185	0,26	145
M1	-14 TGP35	0,10	180	0,13	160	0,15	145	0,19	120
M2	-14 TGP35	0,090	150	0,12	135	0,13	130	0,18	100
M3	-14 TGP35	0,075	120	0,095	110	0,11	105	0,14	90
M4	-14 TGP35	0,065	90	0,080	85	0,095	85	0,12	75
M5	-14 TGP35	0,065	75	0,080	75	0,095	70	0,12	65

TGP45

SMG		$a_p = 1.4$		$a_p = 2.0-2.5$		$a_p = 3$		$a_p = 4$		$a_p = 5-6$	
		f	v_c	f	v_c	f	v_c	f	v_c	f	v_c
P1	-16 TGP45	0,080	300	0,12	290	0,19	235	0,22	210	0,28	165
P2	-16 TGP45	0,080	290	0,13	275	0,20	220	0,22	205	0,28	165
P3	-16 TGP45	0,075	250	0,12	245	0,19	195	0,22	175	0,26	150
P4	-16 TGP45	0,075	220	0,12	215	0,18	180	0,20	165	0,26	130
P5	-16 TGP45	0,075	210	0,11	210	0,18	170	0,20	160	0,26	125
P6	-16 TGP45	0,070	230	0,11	235	0,18	190	0,20	175	0,26	140
P7	-16 TGP45	0,070	220	0,11	220	0,18	180	0,20	165	0,26	135
P8	-16 TGP45	0,075	210	0,12	205	0,19	165	0,22	145	0,26	125
P11	-16 TGP45	0,070	210	0,11	215	0,18	175	0,20	160	0,26	130
M1	-14 TGP45	0,075	170	0,095	165	0,13	140	0,15	130	0,19	105
M2	-14 TGP45	0,065	140	0,085	135	0,12	120	0,13	115	0,18	90
M3	-14 TGP45	0,055	105	0,070	105	0,095	100	0,11	95	0,14	80
M4	-14 TGP45	0,046	75	0,060	80	0,080	75	0,095	75	0,12	65
M5	-14 TGP45	0,046	60	0,060	65	0,080	65	0,095	60	0,12	55

T25M

SMG		ap = 2.25-2.5		ap = 3		ap = 4		ap = 5-6	
		f	v _c	f	v _c	f	v _c	f	v _c
P1	-16 T25M	0,14	250	0,19	210	0,22	190	0,28	150
P2	-16 T25M	0,14	245	0,20	200	0,22	185	0,28	145
P3	-16 T25M	0,14	210	0,19	175	0,22	160	0,26	135
P4	-16 T25M	0,13	190	0,18	160	0,20	150	0,26	120
P5	-16 T25M	0,13	180	0,18	155	0,20	140	0,26	115
P6	-16 T25M	0,13	200	0,18	170	0,20	160	0,26	130
P7	-16 T25M	0,13	190	0,18	165	0,20	150	0,26	120
P8	-16 T25M	0,14	175	0,19	150	0,22	135	0,26	115
P11	-16 T25M	0,13	185	0,18	160	0,20	145	0,26	115
M1	-14 T25M	0,10	145	0,13	125	0,15	115	0,19	95
M2	-14 T25M	0,090	120	0,12	105	0,13	100	0,18	80
M3	-14 T25M	0,075	95	0,095	90	0,11	85	0,14	75
M4	-14 T25M	0,065	70	0,080	70	0,095	65	0,12	60
M5	-14 T25M	0,065	60	0,080	60	0,095	55	0,12	50

T350M

SMG		ap = 2.0-2.25		ap = 2.5		ap = 3		ap = 4	
		f	v _c	f	v _c	f	v _c	f	v _c
P1	-16 T350M	0,12	245	0,14	230	0,19	195	0,22	175
P2	-16 T350M	0,13	230	0,14	225	0,20	185	0,22	170
P3	-16 T350M	0,12	205	0,14	195	0,19	165	0,22	145
P4	-16 T350M	0,12	180	0,13	175	0,18	150	0,20	140
P5	-16 T350M	0,11	175	0,13	165	0,18	145	0,20	130
P6	-16 T350M	0,11	195	0,13	190	0,18	160	0,20	150
P7	-16 T350M	0,11	185	0,13	175	0,18	150	0,20	140
P8	-16 T350M	0,12	170	0,14	165	0,19	140	0,22	125
P11	-16 T350M	0,11	180	0,13	170	0,18	145	0,20	135
M1	-14 T350M	0,095	135	0,10	135	0,13	120	0,15	110
M2	-14 T350M	0,085	115	0,090	110	0,12	100	0,13	95
M3	-14 T350M	0,070	90	0,075	90	0,095	85	0,11	80
M4	-14 T350M	0,060	65	0,065	65	0,080	65	0,095	60
M5	-14 T350M	0,060	55	0,065	55	0,080	55	0,095	50

CP500

SMG		ap = 1.4		ap = 2.0-2.5		ap = 3		ap = 4		ap = 5-6	
		f	v _c	f	v _c	f	v _c	f	v _c	f	v _c
P1	-16 CP500	0,080	205	0,12	180	0,19	150	0,22	140	0,28	125
P2	-16 CP500	0,080	200	0,13	170	0,20	145	0,22	140	0,28	125
P3	-16 CP500	0,075	175	0,12	150	0,19	125	0,22	120	0,26	110
P4	-16 CP500	0,075	155	0,12	130	0,18	115	0,20	110	0,26	95
P5	-16 CP500	0,075	145	0,11	130	0,18	110	0,20	105	0,26	90
P6	-16 CP500	0,070	170	0,11	145	0,18	120	0,20	115	0,26	105
P7	-16 CP500	0,070	160	0,11	140	0,18	115	0,20	110	0,26	100
P8	-16 CP500	0,075	145	0,12	125	0,19	105	0,22	100	0,26	90
P11	-16 CP500	0,070	155	0,11	135	0,18	110	0,20	105	0,26	95
M1	-14 CP500	0,075	235	0,095	225	0,13	190	0,15	175	0,19	145
M2	-14 CP500	0,065	190	0,085	185	0,12	160	0,13	155	0,18	120
M3	-14 CP500	0,055	145	0,070	145	0,095	135	0,11	130	0,14	110
M4	-14 CP500	0,046	105	0,060	110	0,080	105	0,095	100	0,12	90
M5	-14 CP500	0,046	90	0,060	90	0,080	90	0,095	85	0,12	75
K1	-16 CP500	0,080	190	0,13	165	0,20	140	0,22	135	0,28	125
K2	-16 CP500	0,075	165	0,11	140	0,18	115	0,20	105	0,26	90
K3	-16 CP500	0,075	140	0,11	120	0,18	95	0,20	90	0,26	80
K4	-16 CP500	0,075	130	0,11	115	0,18	90	0,20	85	0,26	75
K5	-16 CP500	0,065	80	0,10	70	0,16	55	0,18	55	0,22	48
K6	-16 CP500	0,075	120	0,11	105	0,18	90	0,20	85	0,26	80
K7	-16 CP500	0,065	105	0,10	90	0,16	75	0,18	70	0,22	60
N11	-14 CP500	0,095	125	0,12	115	0,16	105	0,19	95	0,24	85
S1	-14 CP500	0,046	26	0,060	24	0,080	22	0,095	21	0,12	19
S2	-14 CP500	0,046	22	0,060	21	0,080	19	0,095	18	0,12	17
S3	-14 CP500	0,044	20	0,055	18	0,075	17	0,085	16	0,12	14

CP600

SMG		ap = 1.4		ap = 2.0-2.5		ap = 3		ap = 4		ap = 5-6	
		f	v _c	f	v _c	f	v _c	f	v _c	f	v _c
M1	-14 CP600	0,075	240	0,095	220	0,13	180	0,16	150	0,19	130
M2	-14 CP600	0,065	200	0,085	185	0,12	155	0,15	130	0,18	110
M3	-14 CP600	0,055	155	0,070	150	0,095	135	0,12	115	0,14	105
M4	-14 CP600	0,046	110	0,060	115	0,085	105	0,10	95	0,12	85
M5	-14 CP600	0,046	95	0,060	95	0,085	90	0,10	80	0,12	70

HX

SMG		ap = 1.4		ap = 2.0-2.5		ap = 3		ap = 4		ap = 5-6	
		f	v _c	f	v _c	f	v _c	f	v _c	f	v _c
M1	-14 HX	0,075	140	0,095	125	0,13	115	0,15	110	0,19	100
M2	-14 HX	0,065	115	0,085	105	0,12	95	0,13	90	0,18	80
M3	-14 HX	0,055	90	0,070	85	0,095	75	0,11	75	0,14	65
M4	-14 HX	0,046	70	0,060	65	0,080	60	0,095	60	0,12	55
M5	-14 HX	0,046	60	0,060	55	0,080	50	0,095	48	0,12	44
K1	-16 HX	0,080	140	0,13	115	0,20	100	0,22	95	0,28	85
K2	-16 HX	0,075	120	0,11	105	0,18	90	0,20	85	0,26	75
K3	-16 HX	0,075	105	0,11	90	0,18	75	0,20	70	0,26	65
K4	-16 HX	0,075	100	0,11	85	0,18	70	0,20	70	0,26	60
K5	-16 HX	0,065	60	0,10	55	0,16	45	0,18	43	0,22	39
K6	-16 HX	0,075	85	0,11	75	0,18	65	0,20	60	0,26	55
K7	-16 HX	0,065	75	0,10	70	0,16	55	0,18	55	0,22	50
N1	-14 HX	0,095	410	0,12	380	0,16	340	0,19	315	0,24	285
N2	-14 HX	0,095	330	0,12	305	0,16	275	0,19	255	0,24	230
N3	-14 HX	0,095	220	0,12	205	0,16	180	0,19	170	0,24	155
N11	-14 HX	0,095	255	0,12	230	0,16	210	0,19	195	0,24	175
S1	-14 HX	0,046	27	0,060	25	0,080	23	0,095	22	0,12	20
S2	-14 HX	0,046	22	0,060	20	0,080	19	0,095	18	0,12	16
S3	-14 HX	0,044	19	0,055	18	0,075	16	0,085	16	0,12	14
S11	-14 HX	0,055	38	0,070	35	0,095	32	0,11	30	0,14	28
S12	-14 HX	0,055	29	0,070	27	0,095	25	0,11	23	0,14	21
S13	-14 HX	0,046	23	0,060	22	0,080	20	0,095	19	0,12	18
H5	-16 HX	0,050	45	0,080	39	0,12	34	0,14	32	0,17	30

Toolblock 150.10-..20/25 for Parting-off



- For insert programme, see page(s) 649-650

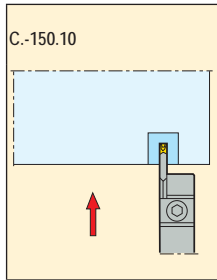
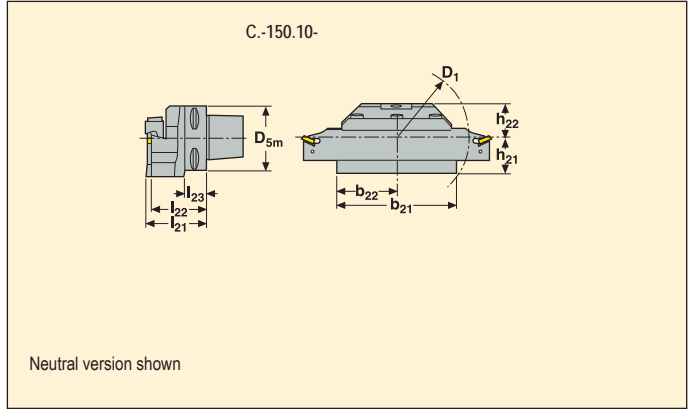

Capto size	Part No.	Dimensions in mm										KG
		D ₁	D _{5m}	b ₂₁	b ₂₂	h ₂₁	h ₂₂	l ₂₁	l ₂₂	l ₂₃		
C5	C5-150.10-40058-20	100	50	80	40	30,0	25,2	58	53	20	1,3	
C6	C6-150.10-60060-25	141	63	120	60	37,0	32,0	60	55	22	2,3	
C8	C8-150.10-60068-25	145	80	120	60	40,5	40,0	68	63	30	3,6	

Spare Parts, Parts included in delivery

For holder	Clamp	Clamp screw	Plug
-20	150.10-647	MC6S8X20	PL1308-H06
-25	150.10-648	MC6S8X25	PL1308-H06

Please check availability in current price and stock-list

Toolblock R/L150.10-..20/25 for Parting-off



• For insert programme, see page(s) 649-650

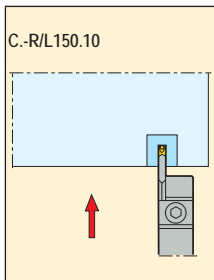
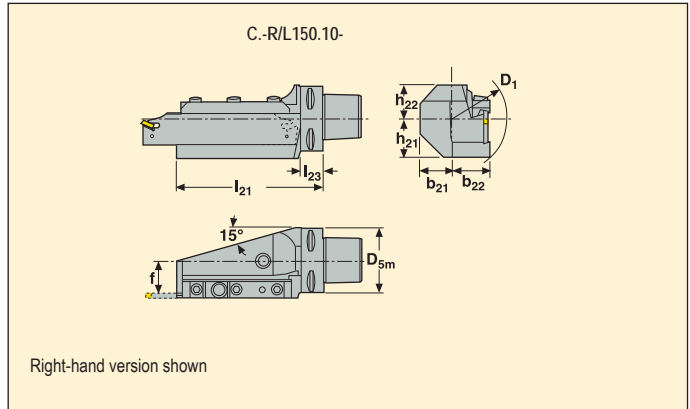

Capto size	Part No.	Dimensions in mm										KG
		D ₁	D _{5m}	b ₂₁	b ₂₂	f	h ₂₁	h ₂₂	l ₂₁	l ₂₃		
C5	C5-R150.10-31095-20	87	50	25,5	31,0	26,0	30,0	26,0	95	20	1,5	
	C5-L150.10-31095-20	87	50	25,5	31,0	26,0	30,0	26,0	95	20	1,5	
C6	C6-R150.10-37147-25	106	63	32,0	37,0	32,0	38,0	32,0	147	22	3,3	
	C6-L150.10-37147-25	106	63	32,0	37,0	32,0	38,0	32,0	147	22	3,3	
C8	C8-R150.10-46155-25	122	80	40,0	45,5	40,5	40,5	40,5	155	30	5,0	
	C8-L150.10-46155-25	122	80	40,0	45,5	40,5	40,5	40,5	155	30	5,0	

Spare Parts, Parts included in delivery

For holder	Clamp	Clamp screw	Plug
-20	150.10-647	MC6S8X20	PL1308-H06
-25	150.10-648	MC6S8X25	PL1308-H06

Please check availability in current price and stock-list

Toolblock R/L150.10-..15 and HSS-blade 150.10A-15 for Parting-off



• For insert programme, see page(s) 649-650

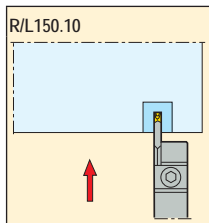
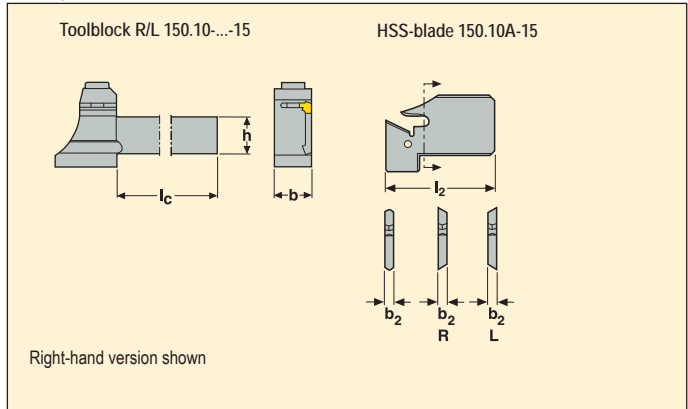

Part No.	Dimensions in mm						
	h	b	l _c	l ₂	b ₂	D _m max	
R150.10 -1010-15	10	10	136	–	–	–	0,2
-1212-15	12	12	136	–	–	–	0,2
-1616-15	16	16	81	–	–	–	0,3
-2020-15	20	20	106	–	–	–	0,5
-2525-15	25	25	106	–	–	–	0,7
L150.10 -1010-15	10	10	136	–	–	–	0,2
-1212-15	12	12	136	–	–	–	0,2
-1616-15	16	16	81	–	–	–	0,3
-2020-15	20	20	106	–	–	–	0,4
-2525-15	25	25	106	–	–	–	0,7
150.10A -15-1.4	–	–	–	33	1,20	38	0,1
-15-2	–	–	–	33	1,80	38	0,1
-15-2.5	–	–	–	33	2,00	38	0,1
-15-3	–	–	–	33	2,40	38	0,1
R150.10A -15-4	–	–	–	33	3,40	38	0,1
L150.10A -15-4	–	–	–	33	3,40	38	0,1

Spare Parts, Parts included in delivery

For holder	Locking key	Locking screw
R/L150.10-...-15	4SMS795	MC6S5X18
150.10A	–	–
R/L150.10A	–	–

Please check availability in current price and stock-list

Parting-off – Toolholders and blades

Toolblock R/L 150.10-..-20/25 and HSS-blade 150.10A-20/25 for Parting-off



• For insert programme, see page(s) 649-650

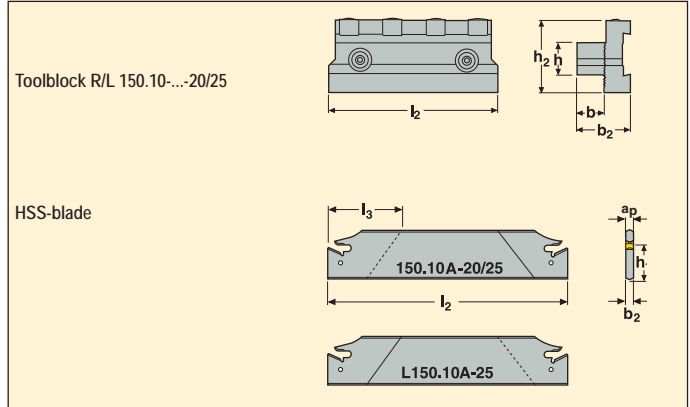

Part No.	Dimensions in mm									
	h	b	h ₁	h ₂	l ₂	b ₂	D _m max	l ₃		
150.10 -1616-20	16	16	–	42,1	100	35,75	–	–	0,7	–
-2020-20	20	20	–	42,1	100	39,75	–	–	0,8	–
150.10 -2520-25	25	20	–	54,0	125	39,75	–	–	1,3	–
-2525-25	25	25	–	54,0	125	44,75	–	–	1,4	–
-3232-25	32	32	–	54,0	125	51,75	–	–	1,8	–
150.10A -20-1.4	–	–	21,4	–	120	1,20	35	24	0,1	150.10-1.4..
-20-2	–	–	21,4	–	120	1,80	35	24	0,1	150.10-2..
-20-2.5	–	–	21,4	–	120	2,00	35	24	0,1	150.10-2.5..
-20-3	–	–	21,4	–	120	2,40	90	–	0,1	150.10-3..
-20-4	–	–	21,4	–	120	3,40	100	–	0,1	150.10-4..
-20-5	–	–	21,4	–	120	4,40	120	–	0,1	150.10-5..
-20-6	–	–	21,4	–	120	5,65	120	–	0,2	150.10-6..
150.10A -25-1.4	–	–	25,0	–	150	1,20	35	24	0,1	150.10-1.4..
-25-2	–	–	25,0	–	150	1,80	35	24	0,1	150.10-2..
-25-2.5	–	–	25,0	–	150	2,00	35	24	0,1	150.10-2.5..
-25-3	–	–	25,0	–	150	2,40	120	–	0,1	150.10-3..
-25-4	–	–	25,0	–	150	3,40	140	–	0,2	150.10-4..
-25-5	–	–	25,0	–	150	4,40	160	–	0,2	150.10-5..
-25-6	–	–	25,0	–	150	5,65	160	–	0,2	150.10-6..
L150.10A -25-1.4	–	–	24,9	–	150	1,20	35	24	0,1	150.10-1.4..

Spare Parts, Parts included in delivery

For holder	Key	Screw	Wedge clamp	Wedge screw
-20	4SMS795	MF6S6X25	150.10-646	150.10-650
-25	4SMS795	MF6S6X25	150.10-646	150.10-650

Please check availability in current price and stock-list

HSS-blade for parting-off, Jetstream Tooling® Duo

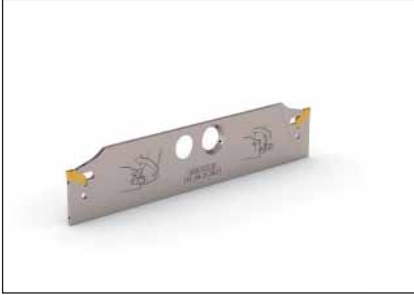

- For insert programme, see page(s) 649-650

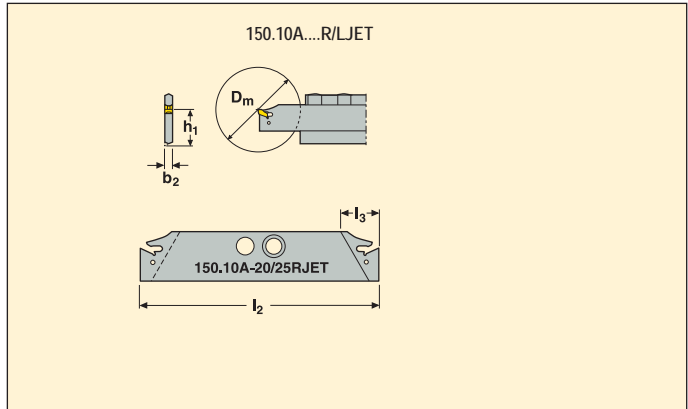

Part No.	Dimensions in mm					 KG	
	h_1	l_2	l_3	b_2	D_m		
150.10A-20 -2RJET	21,4	120	25	1,80	35,0	0,1	150.10-2..
-2LJET	21,4	120	25	1,80	35,0	0,1	150.10-2..
-2.5RJET	21,4	120	25	2,00	35,0	0,1	150.10-2.5..
-2.5LJET	21,4	120	25	2,00	35,0	0,1	150.10-2.5..
-3RJET	21,4	120	-	2,40	83,5	0,1	150.10-3..
-3LJET	21,4	120	-	2,40	83,5	0,1	150.10-3..
-4RJET	21,4	120	-	3,40	83,5	0,1	150.10-4..
-4LJET	21,4	120	-	3,40	83,5	0,1	150.10-4..
150.10A-25 -3RJET	25,0	150	-	2,40	113,5	0,1	150.10-3..
-3LJET	25,0	150	-	2,40	113,5	0,1	150.10-3..
-4RJET	25,0	150	-	3,40	113,5	0,2	150.10-4..
-4LJET	25,0	150	-	3,40	113,5	0,2	150.10-4..
-5RJET	25,0	150	-	4,40	113,5	0,2	150.10-5..
-5LJET	25,0	150	-	4,40	113,5	0,2	150.10-5..
-6RJET	25,0	150	-	5,65	113,5	0,2	150.10-6..
-6LJET	25,0	150	-	5,65	113,5	0,2	150.10-6..

Accessories

For holder	Coolant adapter	Coolant Kit	Key	Screw	Washer
-2, -2.5, -3	JET-CFP0611	150.10A-3-JET-KIT	150.10A-150	JET-CLS0608	JET-CS1115
-4	JET-CFP0613	150.10A-4-JET-KIT	150.10A-150	JET-CLS0608	JET-WM10
-5	JET-CFP0614	150.10A-5-JET-KIT	150.10A-150	JET-CLS0608	JET-WM10
-6	JET-CFP0615	150.10A-6-JET-KIT	150.10A-150	JET-CLS0608	JET-WM10

Please check availability in current price and stock-list

For more information on Jetstream Tooling® and accessories, please see page(s) 27-29 and 684.

Coolant adapter, Screw and Washer included in Coolant kit

Inserts – Parting-off, 150.10...-12 and 150.10...-14

Tolerances:
 $a_p = \pm 0,05$
 $a_p = \pm 0,08$

Size:
 1,4-2,5
 3-6

Toolholder range, see page(s)
 647-648

Size	Dimensions in mm		
	a_p	l_2	rep
1,4	1,40	9	0,15
2,0	2,00	9	0,15
2,25	2,25	9	0,15
2,5	2,50	9	0,17
3	3,10	9	0,19
4	4,10	9	0,23
5	5,10	9	0,26
6	6,35	9	0,30

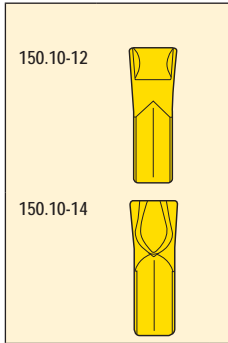

Inserts	Part No.	PSIRR°	PSIRL°	Grades																
				Coated						Uncoated										
				T25M	T350M	CP500	CP600	TCP35	TCP45	HX										
150.10-12	150.10 -2.5N-12	-	-	■	■	■	■	■	■											
	-2.5R6-12	6	-	■			■													
	-2.5L6-12	-	6	■			■													
	150.10 -3N-12	-	-	■	■	■	■	■	■											
	-3R6-12	6	-	■			■													
	-3L6-12	-	6	■			■													
	150.10 -4N-12	-	-	■	■	■	■	■	■											
	-4R6-12	6	-	■																
	-4L6-12	-	6	■																
	150.10 -5N-12	-	-	■					■											
	150.10 -6N-12	-	-	■					■											
	150.10-14	150.10 -1.4N-14	-	-			■	■					■							
150.10 -2.0N-14		-	-		■	■	■		■			■								
-2.25N-14		-	-		■	■	■		■			■								
-2.5N-14		-	-	■	■	■	■		■			■								
-2.5R6-14		6	-	■			■					■								
-2.5L6-14		-	6	■			■					■								
150.10 -3N-14		-	-	■	■	■	■	■	■			■								
-3R6-14		6	-	■			■					■								
-3L6-14		-	6	■			■					■								
150.10 -4N-14		-	-	■	■	■	■	■	■			■								
-4R6-14		6	-	■								■								
-4L6-14		-	6	■								■								
150.10 -5N-14		-	-	■		■	■													
150.10 -6N-14		-	-	■		■	■													

■ Stock standard
 Subject to change refer to current price- and stock-list



General information

The Seco X4 system (multi edge solution) comprises toolholders and inserts for external radial machining.

The system can be used for:

- Grooving
- Parting off

Seco X4 comes in combination with the unique Jetstream Tooling® Duo. A high pressure cooling system which provides directed coolant supply to the cutting edge by two streams: the first to the rake surface and the second to the clearance surface.



The X4 system provides several features:

- Four cutting edges
- Ability to pass free along a shoulder down to the centre
- Easy double access clamping system
- Easy indexing without total extraction of the screw
- Integrity safe in case of edge failure. The inserts can still be used with three broken passive edges.
- Good repeatability ($\pm 0,025$ mm)
- Jetstream Tooling® Duo – improves chip control and tool life of cutting edge



Set-up machining recommendations

The mounting should be stable.

The tool should be securely clamped and the overhang should be as small as possible.

The centre height should never deviate by more than $\pm 0,1$ mm from the workpiece centre.

Parting-off

An insert with a neutral edge (N) normally results in a longer useful life of the insert.

The useful life of the insert can be increased by reducing the feed rate or stopping the feed entirely before breakthrough.

Formulae for cutting data calculation can be found in page(s) 47

Seco Jetstream Tooling® Duo

Seco Jetstream Tooling® Duo holders, yet another innovation introduced to market, feature both a rake face and flank face jet, that may provide even better chip control and significantly longer tool life. For more information on Jetstream Tooling® and accessories, please see page(s) 27-29 and 684.



Troubleshooting

Troubleshooting for X4 inserts, see page(s) 639

X4 – Toolholder, Seco-Capto™

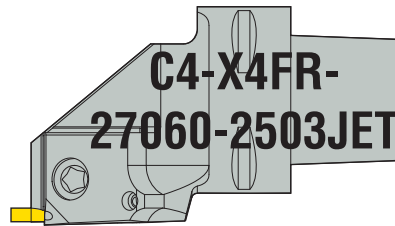

C4	- X4	F	R	27	060	- 25	03	JET
1	2	3	4	5	6	7	8	9

<p>1. Seco-Capto™ size</p> <p style="text-align: center;">D_{sm}</p>	<p>2. Tool system</p> <p>X4</p>	<p>3. Toolholder setting angle</p> <p>$F = 90^\circ$ $G = 0^\circ$</p>
<p>4. Version</p> <p>R = Right-hand version L = Left-hand version</p>	<p>5. Dimension f_1</p> <p style="text-align: center;">f_1</p>	<p>6. Dimension l_1</p> <p style="text-align: center;">l_1</p>
<p>7. Insert length</p> <p style="text-align: center;">l_2</p> <p>25 = 25 mm</p>	<p>8. Seat size</p> <p style="text-align: center;">ϕ</p> <p>03 = 3,1 mm</p>	<p>9. Cooling system</p> <p>JET = Jetstream Tooling® Duo</p>



X4	F	R	25	25	M	25	03	JET
1	2	3	4	5	6	7	8	9

<p>1. Tool system</p> <p>X4</p>	<p>2. Toolholder setting angle</p> <p>F = 90° G = 0°</p>	<p>3. Version</p> <p>R = Right-hand version L = Left-hand version</p>
<p>4. Shank height</p>	<p>5. Shank width</p>	<p>6. Tool length</p> <p>H = 100 mm K = 125 mm M = 150 mm</p>
<p>7. Insert length</p> <p>25 = 25 mm</p>	<p>8. Seat size</p> <p>03 = 3,1 mm</p>	<p>9. Cooling system</p> <p>JET = Jetstream Tooling® Duo</p>

X4 – Inserts

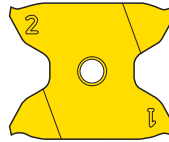

X4	G	K	25	03	010	- 0150	RR15	- MC
1	2	3	4	5	6	7	8	9

1. Tool system	2. Tolerances	3. Insert type								
X4	<p style="text-align: center;">Tolerance ± mm</p> <table border="1"> <thead> <tr> <th>Tol. class</th> <th>ap</th> <th>rep</th> <th>l</th> </tr> </thead> <tbody> <tr> <td>G</td> <td>0,025</td> <td>0,03</td> <td>0,025</td> </tr> </tbody> </table>	Tol. class	ap	rep	l	G	0,025	0,03	0,025	<p>K = four edges with chipbreaker</p>
Tol. class	ap	rep	l							
G	0,025	0,03	0,025							

4. Insert length	5. Seat size	6. Corner radius
<p>25 = 25 mm</p>	<p>03 = 3,1 mm</p>	<p>005 = 0,05 mm 010 = 0,10 mm 015 = 0,15 mm</p> <p>M0 = round</p>

7. Insert width	8. Version	9. Chipbreaker or geometry code
<p>0050 = 0,5 mm 0300 = 3 mm</p>		<p>MC = Chipbreaker for medium Parting-off and Grooving FG = Radial groove R = Round</p>

Grooving

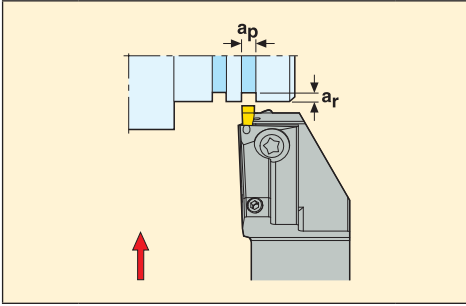

Maximum cutting depth a_r is limited relative to workpiece diameter to avoid contact between workpiece and toolholder.

Grooving – Cutting depth a_r

Cutting edge width a_p	Workpiece diameter, \varnothing mm									
	0-130	130-140	140-160	160-180	180-200	200-250	250-300	300-400	400-500	500-1000
0,5	2,6	2,6	2,6	2,6	2,6	2,6	2,6	2,6	2,6	2,6
1,0	4,3	4,3	4,3	4,3	4,3	4,3	4,3	4,3	4,3	4,0
1,5	6,5	6,4	6,1	5,9	5,5	5,0	5,0	4,5	4,5	4,0
2,0	6,5	6,4	6,1	5,9	5,5	5,0	5,0	4,5	4,5	4,0
2,5	6,5	6,4	6,1	5,9	5,5	5,0	5,0	4,5	4,5	4,0
3,0	6,5	6,4	6,1	5,9	5,5	5,0	5,0	4,5	4,5	4,0

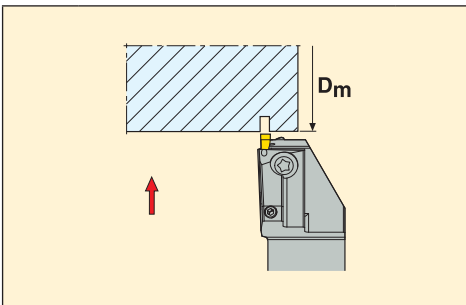

Parting-off



Parting-off – Maximum workpiece diameter, D_m

Cutting edge width a_p	Workpiece diameter, D_m
0,5	5,2
1,0	8,6
1,5	13,0
2,0	13,0
2,5	13,0
3,0	13,0

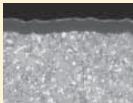
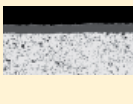
Coated grades

	<p>CP500</p>	<p>Tough PVD-coated micrograin grade intended for grooving, profiling and parting-off at moderate cutting speeds. Provides more wear resistance compared to CP600.</p> <p>(Ti,Al)N + TiN</p>
	<p>CP600</p>	<p>Very tough PVD-coated fine-grain grade, universal choice intended for grooving and parting-off at low to moderate cutting speeds. Well-suited in stainless steel and in interrupted cuts. Tougher alternative to CP500.</p> <p>(Ti,Al)N + TiN</p>
	<p>TGH1050</p>	<p>Very hard supermicrograin grade intended for partly hardened steel components as well as generally work-piece materials such as superalloys and cast-iron and due to remarkable edge toughness it also provides high performance in interrupted cuts and hard-surface removal.</p> <p>Ti-Al-Si-N nanolaminate coating</p>

Grades, PCBN

<p>CBN200</p> 	<p>Inserts with brazed tips, intended for hardened steels and pearlitic cast iron.</p> <p>Composition: 90% cBN content grade with an average grain size of 3-6 µm and a Al ceramic binder.</p> <p>Coating: No coating.</p>
---	--

Grades

The application area for each grade is shown in the chart below.

The black areas in the chart indicate a grade's main ISO application groups and the white areas indicate other supplementary application groups.

		P					M					K					N				S				H						
		P01	P10	P20	P30	P40	P50	M01	M10	M20	M30	M40	K01	K10	K20	K30	K40	N01	N10	N20	N30	S01	S10	S20	S30	H01	H10	H20	H30		
	CP500			●	●	●	●	●	●	●	●	●	●	●	●	●	●	●	●	●	●	●	●					●			
	CP600			●	●	●	●	●	●	●	●					●	●	●	●	●	●	●	●					●			
	TGH1050															●	●	●	●					●	●	●	●				
	CBN200															●	●	●	●									●	●	●	●

Feed rate recommendations for each cutting edge width

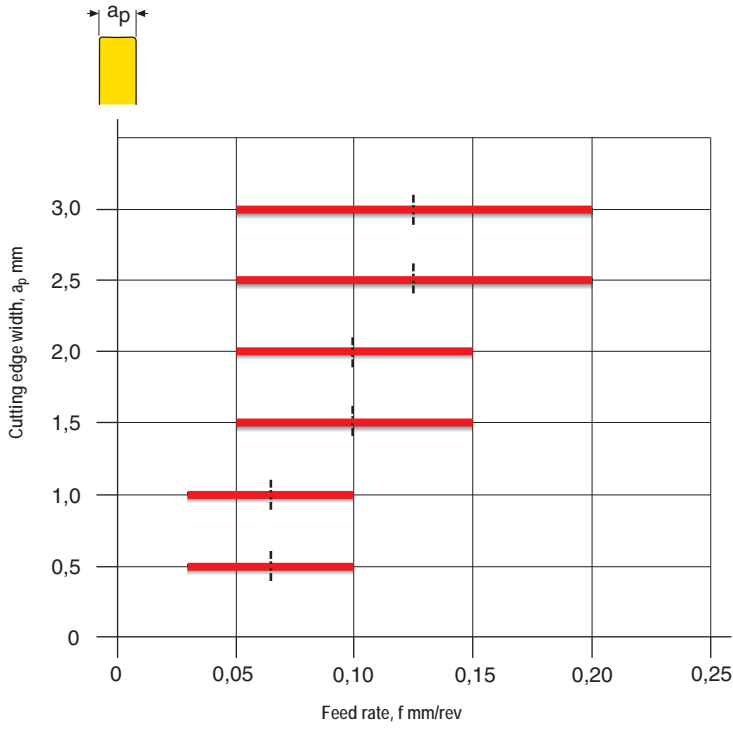

Dotted line indicates start value.

The feed rate recommendations in this diagram are valid for neutral inserts. For angled inserts, R/L, generally a reduction of 30% in the values is recommended.

Cutting speed, v_c (m/min)

In this section a recommended cutting speed is indicated under specified conditions.

Use the tables beginning on page(s) 688 to classify the workpiece material into a SMG.

The cutting data tables provide a recommendation of chipbreaker and a start value for feed rate (f) and cutting speed (v_c).

The cutting data tables are based on grooving with full cutting width (a_p).

The recommended cutting speeds in the tables are calculated for 15 minutes tool life with use of external flood coolant.

In order to increase the accuracy towards the actual cutting conditions and requirements of the applications the recommendation is to use My Pages – Suggest on www.secotools.com

v_c = cutting speed (m/min)

a_p = insert width (mm)

f = feed rate (mm/rev)

CP500

SMG		$a_p = 0.5-1.0$		$a_p = 1.5-2.0$		$a_p = 2.5-3.0$	
		f	v_c	f	v_c	f	v_c
P1	-MC CP500	0,075	180	0,12	155	0,15	140
P2	-MC CP500	0,075	180	0,12	150	0,15	135
P3	-MC CP500	0,075	155	0,11	130	0,14	120
P4	-MC CP500	0,070	135	0,11	115	0,14	105
P5	-MC CP500	0,070	130	0,11	110	0,14	100
P6	-MC CP500	0,070	145	0,11	125	0,13	115
P7	-MC CP500	0,070	140	0,11	120	0,13	110
P8	-MC CP500	0,075	130	0,11	110	0,14	100
P11	-MC CP500	0,070	135	0,11	115	0,13	105
M1	-MC CP500	0,075	205	0,12	175	0,15	150
M2	-MC CP500	0,070	165	0,11	145	0,14	125
M3	-MC CP500	0,055	125	0,085	120	0,11	110
M4	-MC CP500	0,050	90	0,075	95	0,095	85
M5	-MC CP500	0,050	75	0,075	80	0,095	75
K1	-MC CP500	0,075	170	0,12	145	0,15	130
K2	-MC CP500	0,070	145	0,11	120	0,14	110
K3	-MC CP500	0,070	125	0,11	100	0,14	90
K4	-MC CP500	0,070	115	0,11	100	0,14	85
K5	-MC CP500	0,065	70	0,10	60	0,12	55
K6	-MC CP500	0,070	105	0,11	90	0,14	85
K7	-MC CP500	0,065	90	0,10	75	0,12	70
N11	-MC CP500	0,10	110	0,15	90	0,19	85
S1	-MC CP500	0,050	22	0,075	19	0,095	18
S2	-MC CP500	0,050	19	0,075	17	0,095	16
S3	-MC CP500	0,046	17	0,070	15	0,090	14

CP600

SMG		ap = 0.5-1.0		ap = 1.5-2.0		ap = 2.5-3.0	
		f	v _c	f	v _c	f	v _c
P1	-MC CP600	0,075	170	0,12	145	0,15	130
P2	-MC CP600	0,075	165	0,12	140	0,15	130
P3	-MC CP600	0,075	145	0,11	125	0,14	115
P4	-MC CP600	0,070	130	0,11	110	0,14	100
P5	-MC CP600	0,070	125	0,11	105	0,14	95
P6	-MC CP600	0,070	140	0,11	115	0,13	110
P7	-MC CP600	0,070	130	0,11	110	0,13	105
P8	-MC CP600	0,075	120	0,11	105	0,14	95
P11	-MC CP600	0,070	125	0,11	105	0,13	100
M1	-MC CP600	0,075	190	0,12	165	0,15	140
M2	-MC CP600	0,070	155	0,11	140	0,14	120
M3	-MC CP600	0,055	115	0,085	115	0,11	105
M4	-MC CP600	0,050	85	0,075	85	0,095	80
M5	-MC CP600	0,050	70	0,075	75	0,095	70
K1	-MC CP600	0,075	160	0,12	135	0,15	125
K2	-MC CP600	0,070	135	0,11	115	0,14	100
K3	-MC CP600	0,070	115	0,11	95	0,14	85
K4	-MC CP600	0,070	110	0,11	90	0,14	80
K5	-MC CP600	0,065	65	0,10	55	0,12	50
K6	-MC CP600	0,070	100	0,11	85	0,14	80
K7	-MC CP600	0,065	85	0,10	70	0,12	65
N11	-MC CP600	0,10	100	0,15	85	0,19	80
S1	-MC CP600	0,050	21	0,075	18	0,095	17
S2	-MC CP600	0,050	18	0,075	16	0,095	15
S3	-MC CP600	0,046	16	0,070	14	0,090	13

Toolholders for inserts X4GK





• For insert programme, see page(s) 665-668

C.-X4FR/L...JET

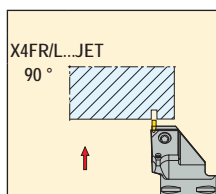

Right-hand version shown
 Right-hand holder must only be used with Right-hand insert (RN/RR/RL)
 Left-hand holder must only be used with Left-hand insert (LN/LR/LL)



Capto size	Part No.	Dimensions in mm			 KG	
		D _{sm}	l ₁	f ₁		
C4	C4-X4FR-27060-2503JET	40	60	27	0,7	X4GK25..RN/RR/RL..
	C4-X4FL-27060-2503JET	40	60	27	0,7	X4GK25..LN/LR/LL..
C5	C5-X4FR-35060-2503JET	50	60	35	0,9	X4GK25..RN/RR/RL..
	C5-X4FL-35060-2503JET	50	60	35	0,9	X4GK25..LN/LR/LL..
C6	C6-X4FR-45065-2503JET	63	65	45	1,2	X4GK25..RN/RR/RL..
	C6-X4FL-45065-2503JET	63	65	45	1,2	X4GK25..LN/LR/LL..

For a_p and a_r, see inserts page(s) 656

Spare Parts, Parts included in delivery

For holder	Clamp key	Clamp screw
		
-2503	T15P-7	L85020-T15P

Please check availability in current price and stock-list

Toolholders for inserts X4GK



• For insert programme, see page(s) 665-668

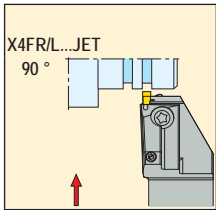
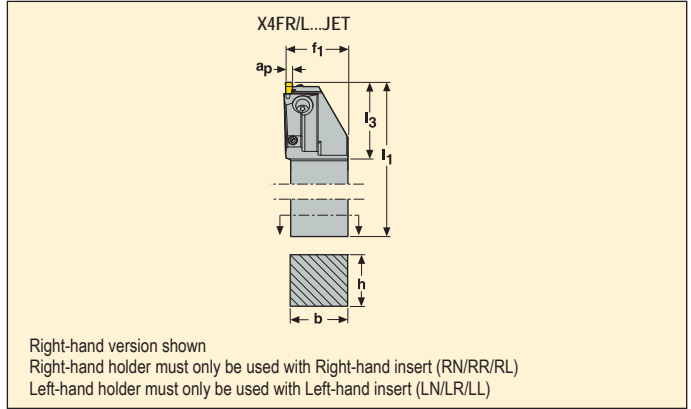

Part No.	Dimensions in mm					KG	
	h	b	l ₁	f ₁	l ₃		
X4FR 1616M2503JET	16	16	150	18	36	0,4	X4GK25..RN/RR/RL...
2020M2503JET	20	20	150	22	36	0,5	X4GK25..RN/RR/RL...
2525M2503JET	25	25	150	28	36	0,7	X4GK25..RN/RR/RL...
X4FL 1616M2503JET	16	16	150	18	36	0,4	X4GK25..LN/LR/LL...
2020M2503JET	20	20	150	22	36	0,5	X4GK25..LN/LR/LL...
2525M2503JET	25	25	150	28	36	0,7	X4GK25..LN/LR/LL...

For ap and a, see inserts page(s) 656

Spare Parts, Parts included in delivery

For holder	Clamp key	Clamp screw	Plug
-2503	T15P-7	L85020-T15P	JET-P1/8-5MM

Please check availability in current price and stock-list
 For more information on Jetstream Tooling® and accessories, please see page(s) 27-29 and 684.

X4 – Toolholders, external

Toolholders for inserts X4GK



- For insert programme, see page(s) 665-668

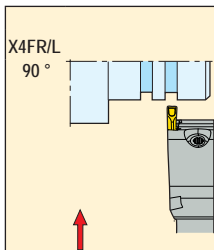
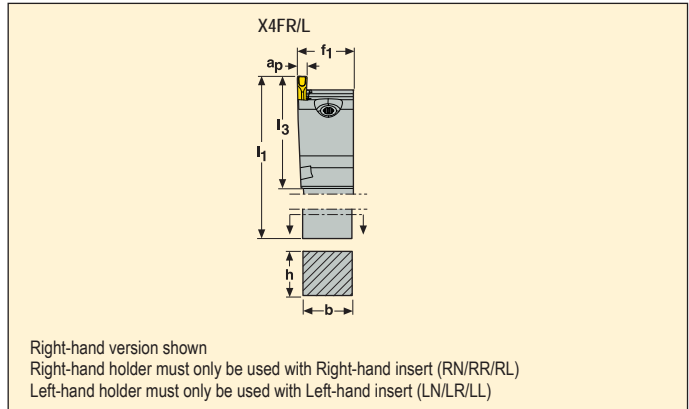

Part No.	Dimensions in mm					KG	
	h	b	l ₁	f ₁	l ₃		
X4FR 2020M2503	20	20	150	22	36	–	X4GK25..RN/RR/RL...
1212K2503	12	12	125	15	37	0,2	X4GK25..RN/RR/RL...
1616K2503	16	16	125	18	37	0,3	X4GK25..RN/RR/RL...
X4FL 2020M2503	20	20	150	22	36	–	X4GK25..LN/LR/LL...
1616K2503	16	16	125	18	37	0,3	X4GK25..LN/LR/LL...
1212K2503	12	12	125	15	37	0,2	X4GK25..LN/LR/LL...

For a_p and a_r, see inserts page(s) 656

Spare Parts, Parts included in delivery

For holder	Clamp key	Clamp screw
-2503	T15P-7	L85020-T15P

Please check availability in current price and stock-list

Toolholders for inserts X4GK



• For insert programme, see page(s) 665-669

X4FR...ITX

Right-hand version shown
 Right-hand holder must only be used with Right-hand insert (RN/RR/RL)
 Left-hand holder must only be used with Left-hand insert (LN/LR/LL)

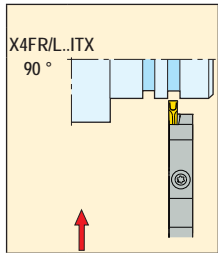

Part No.	Dimensions in mm					KG	
	h	b	l ₁	f ₁	l ₃		
X4FR 26ITX2503R	26	8	120	8	47	0,2	X4GK25..RN/RR/RL...
32ITX2503R	32	8	120	8	47	0,3	X4GK25..RN/RR/RL...
X4FL 26ITX2503R	26	8	120	8	47	0,2	X4GK25..LN/LR/LL...
32ITX2503R	32	8	120	8	47	0,3	X4GK25..LN/LR/LL...
X4FR 26ITX2503L	26	8	120	8	47	0,2	X4GK25..RN/RR/RL...
32ITX2503L	32	8	120	8	47	0,3	X4GK25..RN/RR/RL...
X4FL 26ITX2503L	26	8	120	8	47	0,2	X4GK25..LN/LR/LL...
32ITX2503L	32	8	120	8	47	0,3	X4GK25..LN/LR/LL...

For a_p and a, see inserts page(s) 656

Spare Parts, Parts included in delivery

For size	Clamp key	Clamp screw
26-32	T09P-3	L84017-T09P

Front view

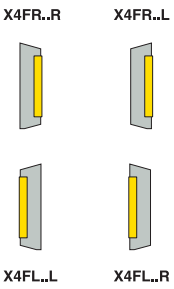

Please check availability in current price and stock-list

X4GK

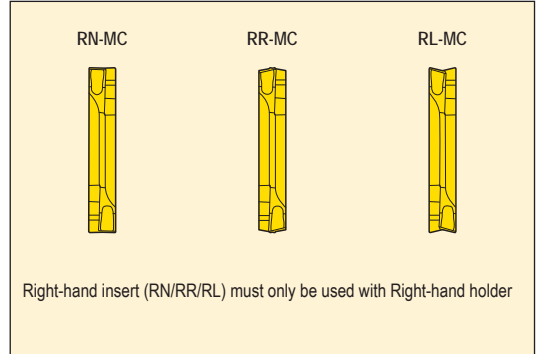
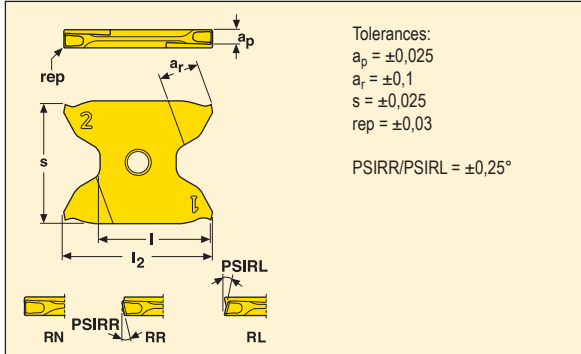

Inserts	Part No.	PSIRR°	PSIRL°	Dimensions in mm						Grades		
				a_p	a_r^*	l	l_2	s	rep	Coated		
										CP500	CP600	TCH1050
X4GK..RN-MC	X4GK 2503005-0050RN-MC	0	0	0,5	2,6	19,0	25,44	20,40	0,05		■	■
	2503005-0100RN-MC	0	0	1,0	4,3	19,0	25,44	20,40	0,05		■	■
	2503010-0150RN-MC	0	0	1,5	6,5	19,0	25,44	20,40	0,10	■	■	■
	2503010-0200RN-MC	0	0	2,0	6,5	19,0	25,44	20,40	0,10	■	■	■
	2503015-0250RN-MC	0	0	2,5	6,5	19,0	25,43	20,39	0,15	■	■	■
	2503015-0300RN-MC	0	0	3,0	6,5	19,0	25,43	20,39	0,15	■	■	■
	2503020-0150RN-MC	0	0	1,5	6,5	19,0	25,44	20,40	0,20	■		
	2503020-0200RN-MC	0	0	2,0	6,5	19,0	25,44	20,40	0,20	■		
	2503030-0250RN-MC	0	0	2,5	6,5	19,0	25,43	20,39	0,30	■		
2503030-0300RN-MC	0	0	3,0	6,5	19,0	25,43	20,39	0,30	■			
X4GK..RR-MC	X4GK 2503005-0100RR15-MC	15	0	1,0	4,3	19,0	25,40	20,36	0,05		■	
	2503005-0150RR15-MC	15	0	1,5	6,5	19,0	25,37	20,34	0,05	■		
	2503010-0150RR15-MC	15	0	1,5	6,5	19,0	25,37	20,34	0,10	■	■	
	2503010-0200RR15-MC	15	0	2,0	6,5	19,0	25,35	20,32	0,10		■	
	2503015-0250RR15-MC	15	0	2,5	6,5	18,9	25,32	20,30	0,15		■	
	2503015-0300RR06-MC	6	0	3,0	6,5	18,9	25,31	20,28	0,15		■	
X4GK..RL-MC	X4GK 2503005-0100RL15-MC	0	15	1,0	4,3	19,0	25,44	20,40	0,05		■	
	2503010-0150RL15-MC	0	15	1,5	6,5	19,0	25,43	20,39	0,10	■	■	
	2503010-0200RL15-MC	0	15	2,0	6,5	19,0	25,43	20,39	0,10		■	
	2503015-0250RL15-MC	0	15	2,5	6,5	19,0	25,43	20,39	0,15		■	
	2503015-0300RL06-MC	0	6	3,0	6,5	19,0	25,43	20,39	0,15		■	

■ Stock standard

Subject to change refer to current price- and stock-list

* Maximum cutting depth a_r is limited relative to workpiece diameter to avoid contact between workpiece and toolholder, see guide pages

X4GK

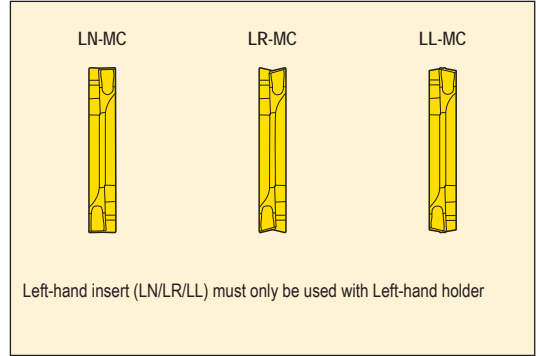
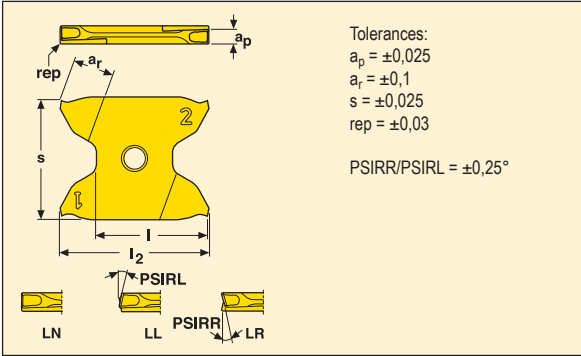

Inserts	Part No.	PSIRR°	PSIRL°	Dimensions in mm						Grades					
				a _p	a _r *	l	l ₂	s	rep	Coated					
										CP500	CP600	TGHT050			
X4GK..LN-MC	X4GK 2503005-0050LN-MC	0	0	0,5	2,6	19,0	25,44	20,40	0,05		■	■			
	2503005-0100LN-MC	0	0	1,0	4,3	19,0	25,44	20,40	0,05		■	■			
	2503010-0150LN-MC	0	0	1,5	6,5	19,0	25,44	20,40	0,10	■	■	■			
	2503010-0200LN-MC	0	0	2,0	6,5	19,0	25,44	20,40	0,10	■	■	■			
	2503015-0250LN-MC	0	0	2,5	6,5	19,0	25,43	20,39	0,15	■	■	■			
	2503015-0300LN-MC	0	0	3,0	6,5	19,0	25,43	20,39	0,15	■	■	■			
	2503020-0150LN-MC	0	0	1,5	6,5	19,0	25,44	20,40	0,20	■					
	2503020-0200LN-MC	0	0	2,0	6,5	19,0	25,44	20,40	0,20	■					
	2503030-0250LN-MC	0	0	2,5	6,5	19,0	25,43	20,39	0,30	■					
	2503030-0300LN-MC	0	0	3,0	6,5	19,0	25,43	20,39	0,30	■					
X4GK..LR-MC	X4GK 2503005-0100LR15-MC	15	0	1,0	4,3	19,0	25,44	20,40	0,05		■				
	2503010-0150LR15-MC	15	0	1,5	6,5	19,0	25,43	20,39	0,10	■	■				
	2503010-0200LR15-MC	15	0	2,0	6,5	19,0	25,43	20,39	0,10		■				
	2503015-0250LR15-MC	15	0	2,5	6,5	19,0	25,43	20,39	0,15		■				
	2503015-0300LR06-MC	6	0	3,0	6,5	19,0	25,43	20,39	0,15		■				
X4GK..LL-MC	X4GK 2503005-0100LL15-MC	0	15	1,0	4,3	19,0	25,40	20,36	0,05		■				
	2503005-0150LL15-MC	0	15	1,5	6,5	19,0	25,37	20,34	0,05		■				
	2503010-0150LL15-MC	0	15	1,5	6,5	19,0	25,37	20,34	0,10	■	■				
	2503010-0200LL15-MC	0	15	2,0	6,5	19,0	25,35	20,32	0,10		■				
	2503015-0250LL15-MC	0	15	2,5	6,5	18,9	25,32	20,30	0,15		■				
	2503015-0300LL06-MC	0	6	3,0	6,5	18,9	25,31	20,28	0,15		■				

■ Stock standard

Subject to change refer to current price- and stock-list

* Maximum cutting depth a_r is limited relative to workpiece diameter to avoid contact between workpiece and toolholder, see guide pages

X4GK

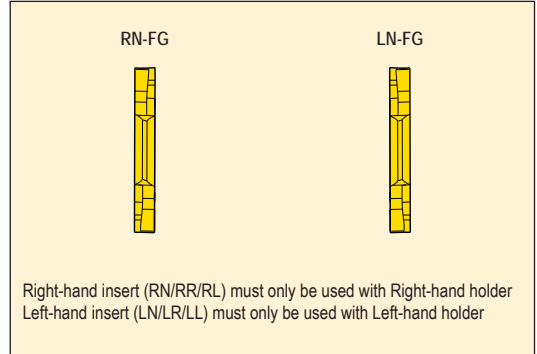
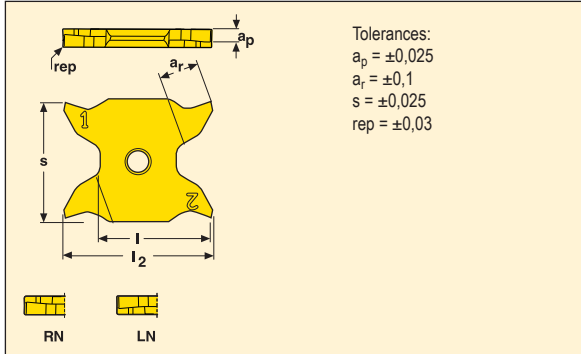

Inserts	Part No.	Dimensions in mm						Grades					
		a_p	a_r^*	l	l_2	s	rep	Coated					
								CP500	CP600	TGH1050			
X4GK..RN-FG for circlip	X4GK 2503010-0115RN-FG	1,15	4,3	19,0	25,44	20,40	0,10	■					
	2503010-0135RN-FG	1,35	4,3	19,0	25,44	20,40	0,10	■					
	2503010-0165RN-FG	1,65	6,5	19,0	25,44	20,40	0,10	■					
	2503010-0190RN-FG	1,90	6,5	19,0	25,44	20,40	0,10	■					
	2503015-0215RN-FG	2,15	6,5	19,0	25,43	20,39	0,15	■					
	2503015-0265RN-FG	2,65	6,5	19,0	25,43	20,39	0,15	■					
X4GK..RN-FG	X4GK 2503005-0050RN-FG	0,50	2,6	19,0	25,44	20,40	0,05			■			
	2503005-0100RN-FG	1,00	4,3	19,0	25,44	20,40	0,05			■			
	2503010-0150RN-FG	1,50	6,5	19,0	25,44	20,40	0,10			■			
	2503010-0200RN-FG	2,00	6,5	19,0	25,44	20,40	0,10			■			
	2503015-0250RN-FG	2,50	6,5	19,0	25,44	20,40	0,15			■			
	2503015-0300RN-FG	3,00	6,5	19,0	25,44	20,40	0,15			■			
X4GK..LN-FG for circlip	X4GK 2503010-0115LN-FG	1,15	4,3	19,0	25,44	20,40	0,10	■					
	2503010-0135LN-FG	1,35	4,3	19,0	25,44	20,40	0,10	■					
	2503010-0165LN-FG	1,65	6,5	19,0	25,44	20,40	0,10	■					
	2503010-0190LN-FG	1,90	6,5	19,0	25,44	20,40	0,10	■					
	2503015-0215LN-FG	2,15	6,5	19,0	25,43	20,39	0,15	■					
	2503015-0265LN-FG	2,65	6,5	19,0	25,43	20,39	0,15	■					
X4GK..RN-FG	X4GK 2503005-0050LN-FG	0,50	2,6	19,0	25,44	20,40	0,05			■			
	2503005-0100LN-FG	1,00	4,3	19,0	25,44	20,40	0,05			■			
	2503010-0150LN-FG	1,50	6,5	19,0	25,44	20,40	0,10			■			
	2503010-0200LN-FG	2,00	6,5	19,0	25,44	20,40	0,10			■			
	2503015-0250LN-FG	2,50	6,5	19,0	25,44	20,40	0,15			■			
	2503015-0300LN-FG	3,00	6,5	19,0	25,44	20,40	0,15			■			

■ Stock standard

Subject to change refer to current price- and stock-list

* Maximum cutting depth a_r is limited relative to workpiece diameter to avoid contact between workpiece and toolholder, see guide pages

X4G

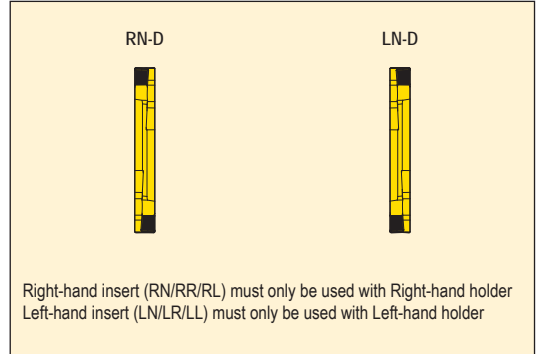
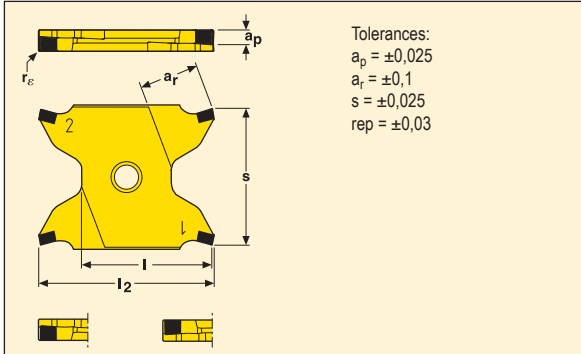

Inserts	Part No.	Dimensions in mm						Grades				
		a_p	a_r^*	l	l_2	s	rep	Coated				
X4G..RN-D	X4G 250315S-0215RN-D	2,15	6,5	19	25	20,361	0,15	■				
X4G..LN-D	X4G 250315S-0215LN-D	2,15	6,5	19	25	20,361	0,15	■				

■ Stock standard

Subject to change refer to current price- and stock-list

* Maximum cutting depth a_r is limited relative to workpiece diameter to avoid contact between workpiece and toolholder, see guide pages

Selection of VDI clamping unit

Internal/Toolholder Right Clamping unit LC	External/Toolholder Right Clamping unit RC	Internal/Toolholder Right Clamping unit RC	External/Toolholder Right Clamping unit LC
Internal/Toolholder Right	External/Toolholder Right	Internal/Toolholder Right	External/Toolholder Right

Note: The polygon socket has to be rotated 180°

Selection of VDI clamping unit

Internal/Toolholder Left Clamping unit LC	External/Toolholder Left Clamping unit RC	Internal/Toolholder Left Clamping unit RC	External/Toolholder Left Clamping unit LC
Internal/Toolholder Left	External/Toolholder Left	Internal/Toolholder Left	External/Toolholder Left

Note: The polygon socket has to be rotated 180°

Selection of clamping unit 2000/3000/2085

	<p>Internal/Toolholder Right NC 2000/3000 Upside-down</p>	<p>External/Toolholder Right RC 2085 Upside-down</p>
	<p>Internal/Toolholder Right NC 2000/3000</p>	<p>External/Toolholder Right RC 2085</p>

Selection of clamping unit 2000/3000/2085

	<p>Internal/Toolholder Left NC 2000/3000</p>	<p>External/Toolholder Left LC 2085</p>
	<p>Internal/Toolholder Left NC 2000/3000 Upside-down</p>	<p>External/Toolholder Left LC 2085 Upside-down</p>

2000 = cylindrical type with drawbar, 3000 = cylindrical type with screw, 2085 = shank type.

Clamping unit 2090 for special applications

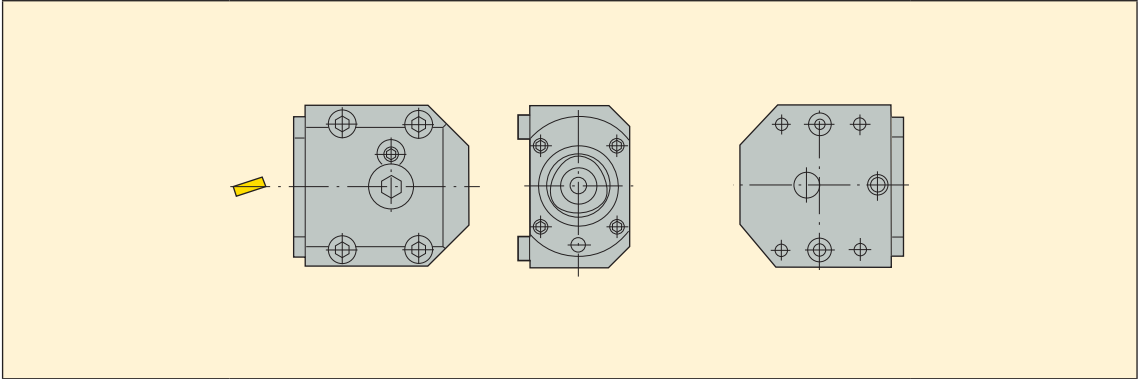

Design instruction™ for application of clamping unit RC/LC 2090

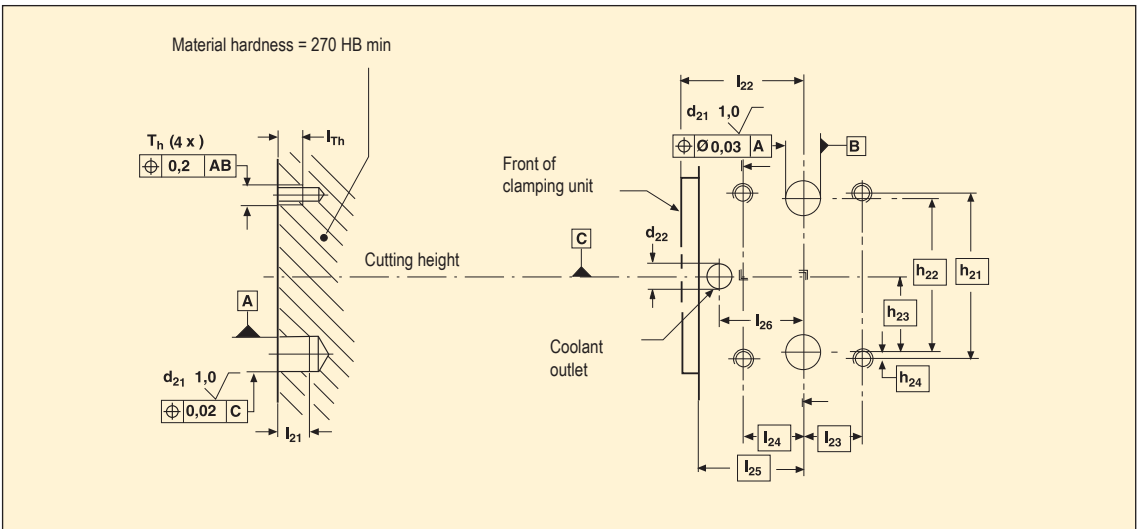

Seco-Capto™ size	Part No.	Dimensions in mm													
		d ₂₁ H7	d ₂₂	h ₂₁	h ₂₂	h ₂₃	h ₂₄	l ₂₁ min	l ₂₂	l ₂₃	l ₂₄	l ₂₅	l ₂₆	l _{Th} min	T _h
C3	C3-R/LC2090-19039M	12	5	42	39	19,5	1,5	8,5	39	19,0	19,0	33,5	28	7,5	M6
C4	C4-R/LC2090-24043A	16	7	60	5	27,5	2,5	11,0	43	19,0	19,0	36,5	30	11,0	M8
C5	C5-R/LC2090-32048A	20	7	70	62	31,0	4,0	12,0	48	21,0	21,0	39,5	33	13,0	M10
C6	C6-R/LC2090-42060	25	10	82	71	35,5	5,5	20,0	60	24,5	24,5	50,0	41	12,0	M10
C8	C8-R/LC2090-50088	32	11	110	92	46,0	9,0	20,0	88	43,0	43,0	76,0	63	14,5	M12

Toolholders

A large range of Seco-Capto toolholders is available:
 For external and internal turning with negative inserts.
 For external and internal turning with positive inserts.
 For external and internal turning with MDT inserts.
 For external and internal threading.

For selection of toolholder use the guidelines for conventional tools.

Cover plug

A cover plug should always be used to protect the ground surfaces of the connecting sleeve from dirt or damage on the clamping units, when they do not have a cutting unit coupled or when they are held in stock.

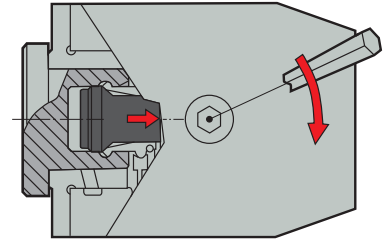

Clamping force

In order to obtain the necessary clamping force (F) the clamping unit should be tightened to the torque value (Mv) as recommended in the table below.

Torque Mv		
Size	Nm	Lbft
C3	35	26
C4	50	37
C5	70	52
C6	90	67
C8	130	96

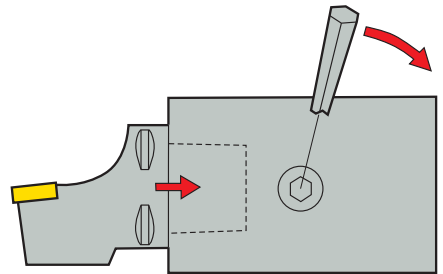

Turning the cutting tool 180°

If the entire clamping unit has to be rotated 180°, the polygon socket should be rotated 180°.

1. Loosen the screws (2).
2. Dismantle the polygon socket. Use the special tool as described on page(s) 685 (ordered separately).
3. Move the guiding pin to the opposite side of the clamping unit.
4. Rotate the polygon socket 180° and reassemble. Tap carefully with a plastic mallet.

Lubrication

All manual clamping units are lubricated with BP Energrease ACS-2 prior to delivery (Alternative MOBIL Temp Shc 32 or STATOIL Beacon 325). The lubrication should be checked every six months. New grease can be applied via the cam.

1. Remove the screw (1).
2. Assemble grease nipple 5692 012-01.
3. Pump in grease with grease gun until it begins to seep out around the key handle at the cam.
4. Remove grease nipple.
5. Replace screw (1) into the cam.

Note: Clamping unit must be clamped during lubrication.

Straight shank type



- How to select Clamping unit, see page(s) 671
- Spare Parts, see page(s) 679

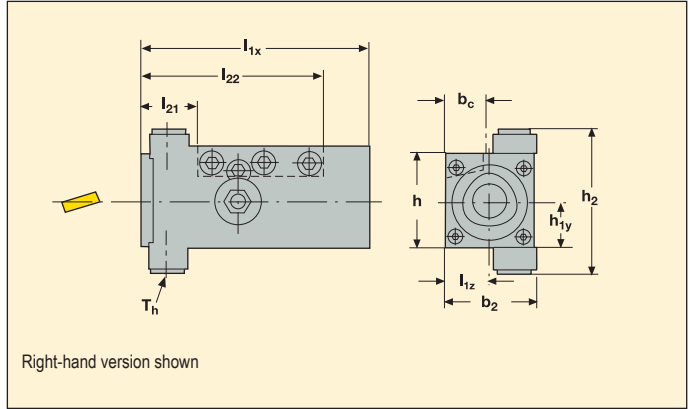

Capto size	Shank	h mm	Part No.	Dimensions in mm									KG
				h _{1y}	l _{1x}	l _{f1}	l _{f2}	b ₂	l _{1z}	b _c	h ₂	T _n	
C3	2020	40	C3-LC2085-4038M	20	95	78,5	25,0	38	19	20	62	G1/8	1,04
	2020	40	C3-RC2085-4038M	20	95	78,5	25,0	38	19	20	62	G1/8	1,05
C4	2525	50	C4-LC2085-5048	25	125	101,0	30,5	48	24	25	54	G1/8	2,02
	2525	50	C4-RC2085-5048	25	125	101,0	30,5	48	24	25	54	G1/8	2,06
C5	3232	64	C5-LC2085-6464	32	145	118,0	36,0	64	32	32	68	G1/8	4,08
	3232	64	C5-RC2085-6464	32	145	118,0	36,0	64	32	32	68	G1/8	4,06

Please check availability in current price and stock-list

VDI type angled DIN69880



- How to select Clamping unit, see page(s) 670
- Spare Parts, see page(s) 681

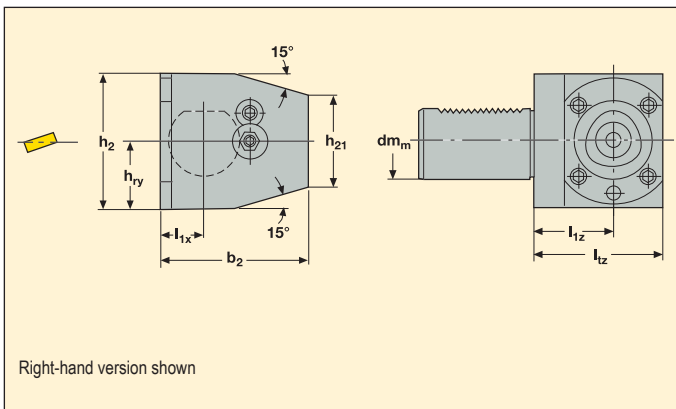

Capto size	VDI dm _m	Part No.	Dimensions in mm							KG
			l _{1z}	l _{2z}	l _{1x}	b ₂	h ₂	h _{fy}	h _f	
C3	30	C3-RC2030-41020M	41	60	20	74	57	30	38	1,9
	30	C3-LC2030-41020M	41	60	20	74	57	30	38	1,9
	30	C3-RC2030-41030M	41	60	30	73	57	30	41	2,0
	30	C3-LC2030-41030M	41	60	30	73	57	30	41	2,0
C4	40	C4-RC2040-51030M	51	75	30	86	75	38	54	3,8
	40	C4-LC2040-51030M	51	75	30	86	75	38	54	3,8
	40	C4-RC2040-51040M	51	75	40	86	75	38	60	4,0
	40	C4-LC2040-51040M	51	75	40	86	75	38	60	4,0
C5	40	C5-RC2040-53030M	53	85	30	99	82	41	47	4,9
	40	C5-LC2040-53030M	53	85	30	99	82	41	47	4,9
	40	C5-RC2040-53040M	53	85	40	99	82	41	53	5,0
	40	C5-LC2040-53040M	53	85	40	99	82	41	53	5,0
	50	C5-RC2050-53030M	53	85	30	99	86	43	59	5,8
	50	C5-LC2050-53030M	53	85	30	99	86	43	59	5,8
	50	C5-RC2050-53040M	53	85	40	99	86	43	65	6,0
	50	C5-LC2050-53040M	53	85	40	99	86	43	65	6,0
	60	C5-RC2060-43040M	43	75	40	99	94	53	76	6,8
	60	C5-LC2060-43040M	43	75	40	99	94	53	76	6,8
C6	60	C6-RC2060-53040	53	95	40	122	105	53	70	9,6
	60	C6-LC2060-53040	53	95	40	122	105	53	70	9,6

Please check availability in current price and stock-list

VDI type straight DIN69880



- How to select Clamping unit, see page(s) 670
- Spare Parts, see page(s) 682

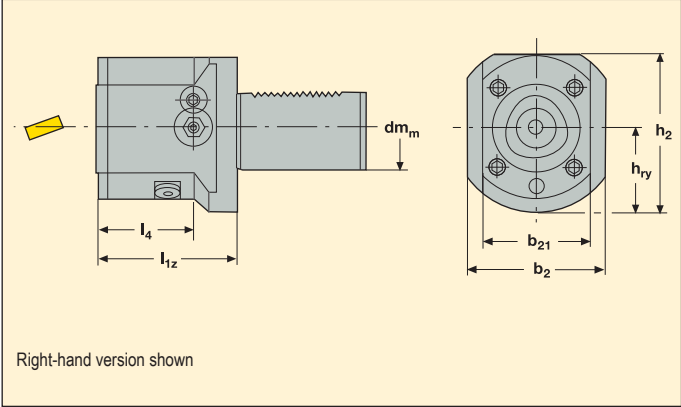

Capto size	VDI dm_m	Part No.	Dimensions in mm						 KG
			l_{1z}	h_f	b_2	l_z	h_2	h_{fy}	
C3	30	C3-RC2030-00060M	60	44	50	38	61	34	1,1
	30	C3-LC2030-00060M	60	44	50	38	61	34	1,1
C4	40	C4-RC2040-00075M	75	53	75	48	75	41	2,2
	40	C4-LC2040-00075M	75	53	75	48	75	41	2,2
C5	40	C5-RC2040-00085M	85	72	83	64	82	41	3,3
	40	C5-LC2040-00085M	85	72	83	64	82	41	3,3
C4	50	C4-RC2050-00065M	65	39	70	70	83	49	2,6
	50	C4-LC2050-00065M	65	39	70	70	83	49	2,6
C5	60	C5-RC2060-00075M	75	16	80	75	100	58	5,2
	60	C5-LC2060-00075M	75	16	80	75	100	58	5,2
C5	50	C5-RC2050-00085M	85	61	83	85	91	49	4,0
	50	C5-LC2050-00085M	85	61	83	85	91	49	4,0
C6	60	C6-RC2060-00095	95	50	84	95	111	58	6,9
	60	C6-LC2060-00095	95	50	84	95	111	58	6,9

Please check availability in current price and stock-list

Manually operated clamping unit – Type 2085

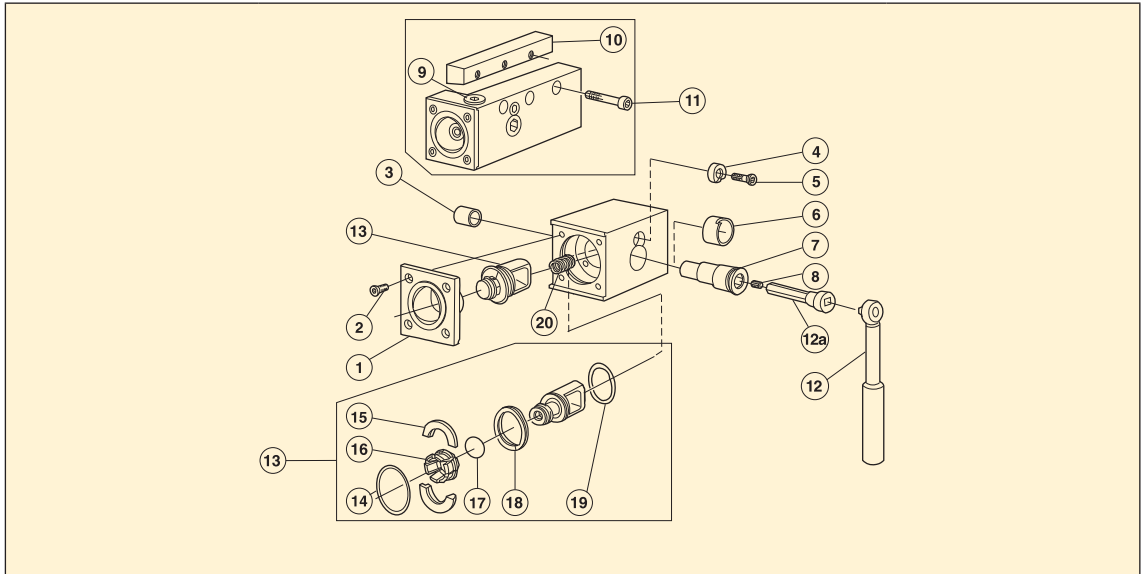

Size	1 Sleeve	2 Screw (4x)	3 Bushing	4 Locking washer	5 Screw
C3	5252 015-01	416.1-834	3823 010-101	5541 030-01	416.1-834
C4	5252 015-02	5513 020-26	3823 010-122	5541 030-02	416.1-834
C5	5252 015-03	5513 020-14	3823 010-162	5541 030-03	5513 020-14

Size	6 Bushing	7 Cam shaft	8 Screw	9 Plug	10 Metric wedge
C3	5638 022-01	5333 025-01	3214 010-355	3611 005-180	5431 115-01
C4	5638 022-02	5333 025-02	3214 010-355	3611 005-180	5431 115-02
C5	5638 022-03	5333 025-03	3214 010-355	3611 005-180	5431 115-03

Size	11 Screw	12 Torque wrench	12a Adapter	20 Compression spring
C3	3212 010-362	BT-TK-02	5680 035-05	5561 001-71
C4	3212 010-364	C-TK-01	5680 035-06	5561 001-41
C5	3212 010-416	C-TK-01	5680 035-07	5561 001-41

Draw bar set

Parts included in draw bar set

Size	13 Draw bar set	14 Spiral retaining ring	15 Holder ring (set of 2)	16 Segment (set of 6)	17 O-ring	18 Flat wire spring	19 O-ring
C3	5461 100-101	5545 039-01	5546 001-16	5549 120-08	5641 005-01	5561 015-02	5641 005-15
C4	5461 100-111	5545 039-03	5546 001-20	5549 120-06	5641 005-05	5561 015-03	5641 005-19
C5	5461 100-121	5545 039-02	5546 001-17	5549 120-07	5641 005-06	5561 015-04	5641 005-16

Manually operated clamping unit – Type 2000

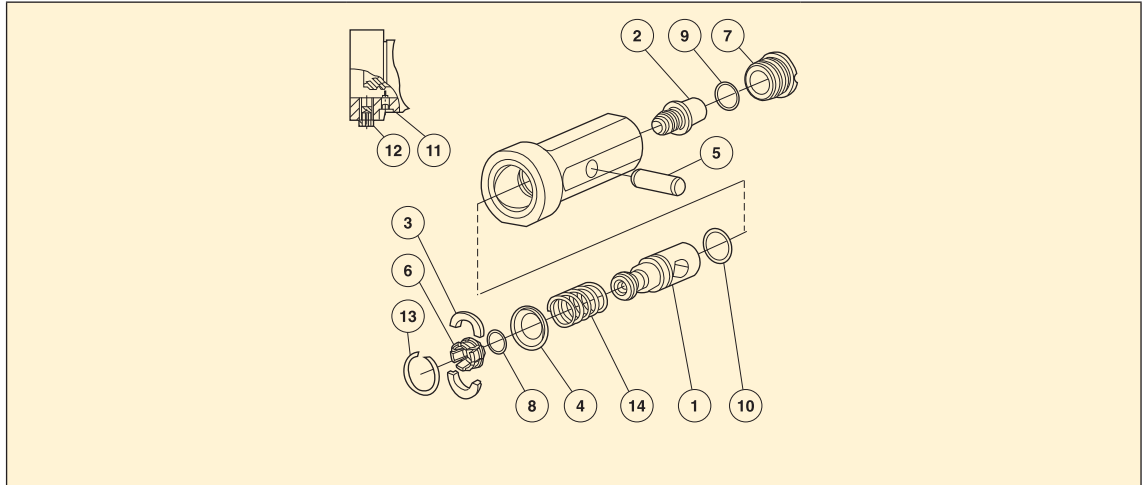

Size	1 Drawbar	2 Clamping screw	3 Holder ring (set of 2)	4 Ring	5 Support pin	6 Segment (set of 6)	7 Thread ring	8 O-ring
C3	5461 105-01	5519 105-01	5546 002-01	5541 028-01	5552 032-01	5549 120-08	5512 091-03	5641 005-01
C4	5461 105-02	5519 105-02	5546 002-02	5541 028-02	5552 032-02	5549 120-06	5512 091-01	5641 005-05
C5	5461 105-03	5519 105-03	5546 002-03	5541 028-03	5552 032-03	5549 120-07	5512 091-02	5641 005-06

Size	9 Drawbar	10 Clamping screw	11 Holder ring (set of 2)	12 Ring	13 Support pin	14 Segment (set of 6)	Key (size, mm)
C3	3671 010-118	3671 010-124	3214 020-204	3611 005-180	5545 042-01	5561 001-52	3021 013-080 (8,0)
C4	3671 010-120	3671 010-126	3214 020-255	3611 005-180	3421 105-026	5561 001-53	5680 010-03 (10,0)
C5	3671 010-124	3671 010-128	3214 020-255	3611 005-180	3421 105-032	5561 001-54	5680 010-04 (12,0)

Manually operated clamping unit – Type 3000

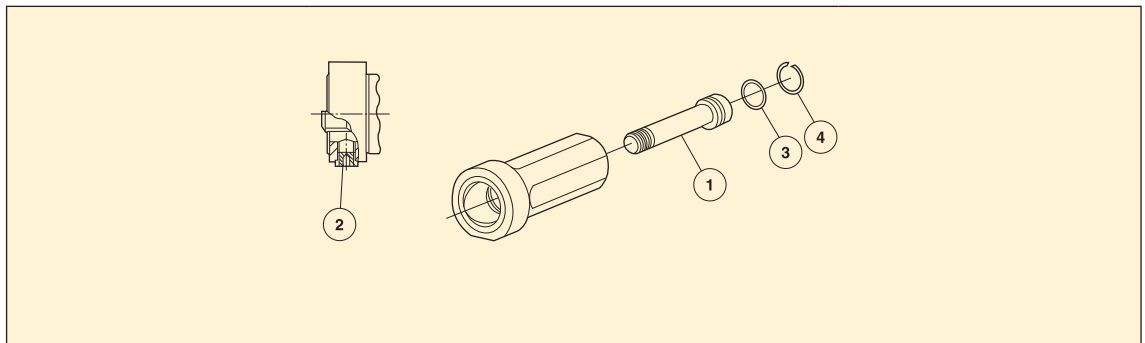

Size	1 Clamping screw	2 Blind plug	3 O-ring	4 Retaining ring	Key (size, mm)
C3	5512 096-01	3611 005-180	3671 010-020	5545 040-03	3021 013-080 (8,0)
C4	5512 096-02	3611 005-180	3671 010-022	5545 040-05	5680 010-03 (10,0)
C5	5512 096-03	3611 005-180	3671 010-024	5545 040-06	5680 010-04 (12,0)

Manually operated clamping unit – VDI angled design, DIN 69880

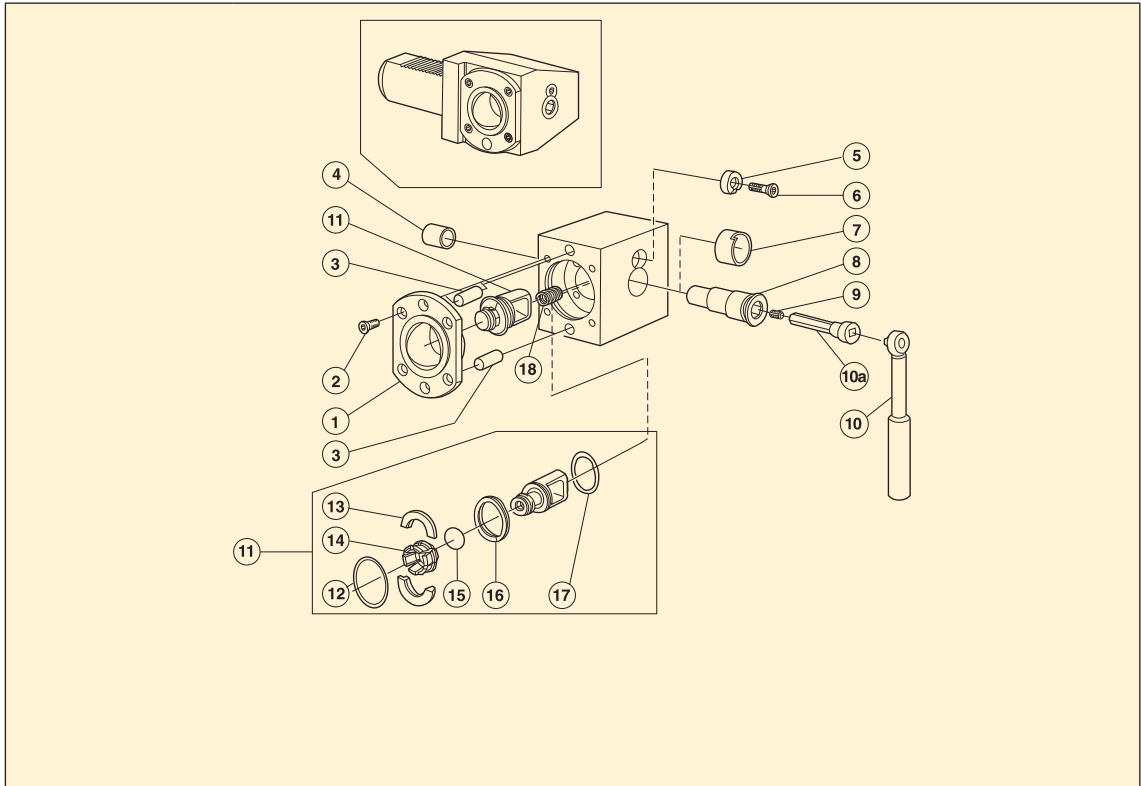

Size	1 Sleeve	2 Screw (4x)	3 Pin	4 Bushing	5 Locking washer	6 Screw
C3	5252 010-01	416.1-834	3111 050-558	3823 010-101	5541 030-01	416.1-834
C4	5252 010-02	5513 020-26	3111 050-610	3823 010-122	5541 030-02	416.1-834
C5	5252 010-03	5513 020-14	3111 050-661	3823 010-162	5541 030-03	5513 020-14
C6	5252 010-04	3213 010-410	3111 050-715	3823 010-183	5541 030-04	5513 020-14

Size	7 Bushing	8 Cam shaft	9 Screw	10 Torque wrench	10a Adapter	18 Compression spring
C3	5638 022-01	5333 025-01	3214 010-355	BT-TK-02	5680 035-05	5561 001-71
C4	5638 022-02	5333 025-02	3214 010-355	C-TK-01	5680 035-06	5561 001-41
C5	5638 022-03	5333 025-03	3214 010-355	C-TK-01	5680 035-07	5561 001-41
C6	5638 022-04	5333 025-04	3214 010-355	C-TK-01	5680 035-07	5561 001-41

Draw bar set

Parts included in draw bar set

Size	11 Draw bar set	12 Spiral retaining ring	13 Holder ring (set of 2)	14 Segment (set of 6)	15 O-ring	16 Flat wire spring	17 O-ring
C3	5461 100-101	5545 039-01	5546 001-16	5549 120-08	5641 005-01	5561 015-02	5641 005-15
C4	5461 100-111	5545 039-03	5546 001-20	5549 120-06	5641 005-05	5561 015-03	5641 005-19
C5	5461 100-121	5545 039-02	5546 001-17	5549 120-07	5641 005-06	5561 015-04	5641 005-16
C6	5461 100-131	5545 039-04	5546 001-18	5549 120-04	5641 005-04	5561 015-05	5641 005-17

Manually operated clamping unit – VDI straight design, DIN 69880

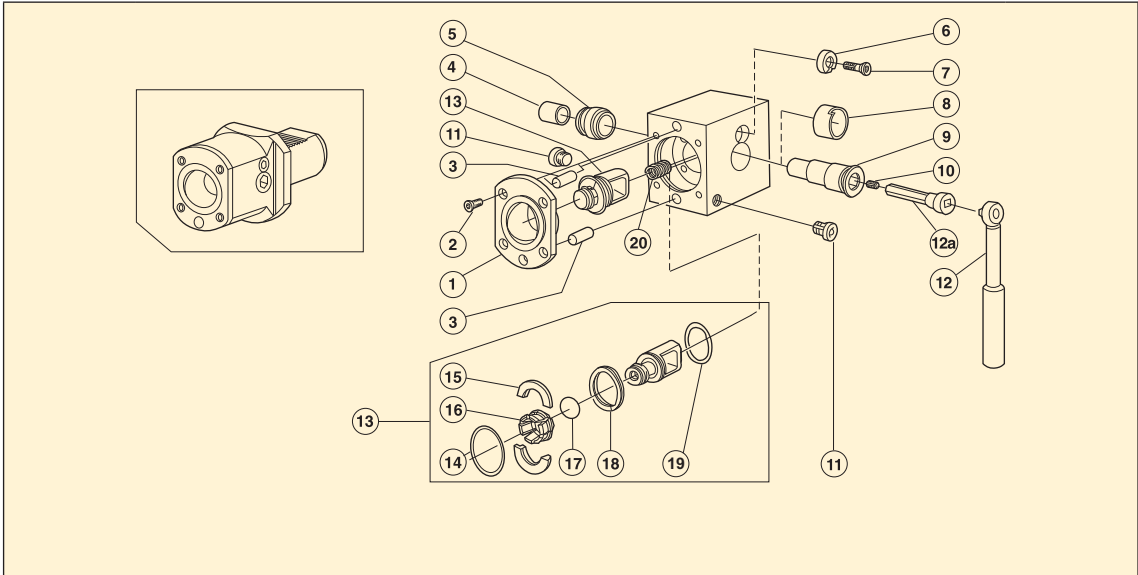

Size	1 Sleeve	2 Screw (4x)	3 Pin	4 Bushing	5 Sleeve
C3	5252 010-01	416.1-834	3111 050-558	3823 010-101	5638 024-01
C4	5252 010-02	5513 020-26	3111 050-610	3823 010-122	5638 024-02
C5	5252 010-03	5513 020-14	3111 050-661	3823 010-162	5638 024-03
C6	5252 010-04	3213 010-410	3111 050-715	3823 010-183	5638 024-04

Size	6 Locking washer	7 Screw	8 Bushing	9 Cam shaft	10 Screw
C3	5541 030-01	416.1-834	5638 022-01	5333 025-01	3214 010-355
C4	5541 030-02	416.1-834	5638 022-02	5333 025-02	3214 010-355
C5	5541 030-03	5513 020-14	5638 022-03	5333 025-03	3214 010-355
C6	5541 030-04	5513 020-14	5638 022-04	5333 025-04	3214 010-355

Size	11 Plug	12 Torque wrench	12a Adapter	20 Compression spring
C3	3611 005-180	BT-TK-02	5680 035-05	5561 001-71
C4	3611 005-180	C-TK-01	5680 035-06	5561 001-41
C5	3611 005-180	C-TK-01	5680 035-07	5561 001-41
C6	3611 005-140	C-TK-01	5680 035-07	5561 001-41

Draw bar set

Parts included in draw bar set

Size	13 Draw bar set	14 Spiral retaining ring	15 Holder ring (set of 2)	16 Segment (set of 6)	17 O-ring	18 Flat wire spring	19 O-ring
C3	5461 100-101	5545 039-01	5546 001-16	5549 120-08	5641 005-01	5561 015-02	5641 005-15
C4	5461 100-111	5545 039-03	5546 001-20	5549 120-06	5641 005-05	5561 015-03	5641 005-19
C5	5461 100-121	5545 039-02	5546 001-17	5549 120-07	5641 005-06	5561 015-04	5641 005-16
C6	5461 100-131	5545 039-04	5546 001-18	5549 120-04	5641 005-04	5561 015-05	5641 005-17

Manually operated clamping unit – Type 2090

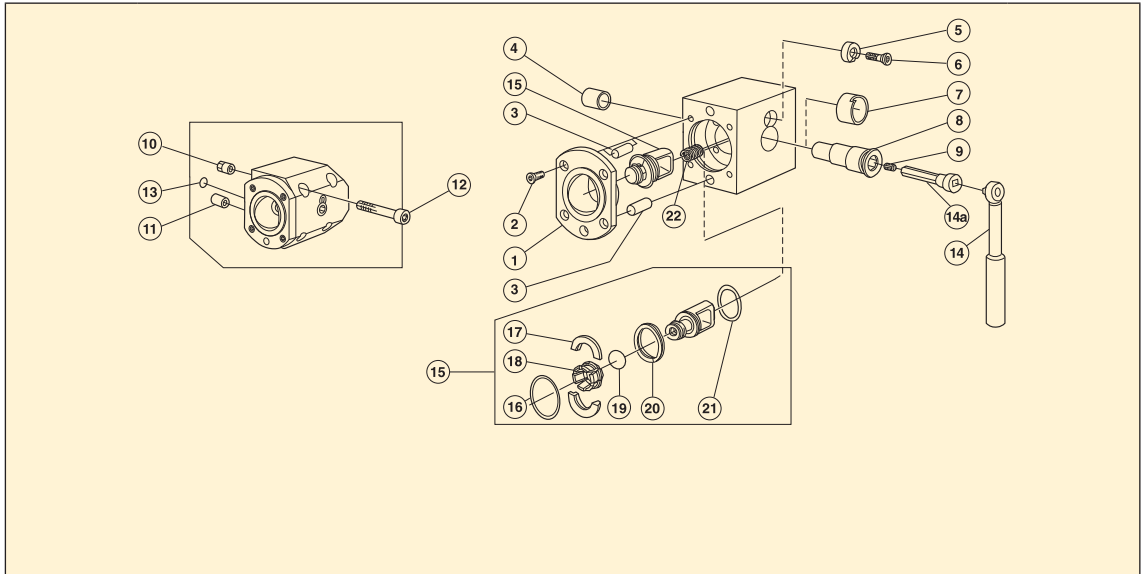

Size	1 Sleeve	2 Screw (4x)	3 Pin	4 Bushing	5 Locking washer	6 Screw
C3	5252 010-01	416.1-834	3111 050-558	3823 010-101	5541 030-01	416.1-834
C4	5252 010-02	5513 020-26	3111 050-610	3823 010-122	5541 030-02	416.1-834
C5	5252 010-03	5513 020-14	3111 050-661	3823 010-162	5541 030-03	5513 020-14
C6	5252 010-04	3213 010-410	3111 050-715	3823 010-183	5541 030-04	5513 020-14
C8	5252 010-05	3213 010-462	3111 050-769	3823 010-225	5541 030-05	5513 020-14

Size	7 Bushing	8 Cam shaft	9 Screw	10 Locating pin	11 Dowel pin	12 Screw
C3	5638 022-01	5333 025-01	3214 010-355	5552 063-05	5552 061-07	3212 010-363
C4	5638 022-02	5333 025-02	3214 010-355	5552 063-07	5552 061-09	3212 010-414
C5	5638 022-03	5333 025-03	3214 010-355	5552 063-06	5552 061-08	3212 010-466
C6	5638 022-04	5333 025-04	3214 010-355	5552 063-03	5552 061-05	3212 010-469
C8	5638 022-05	5333 025-05	3214 010-355	5552 063-04	5552 061-06	3212 010-521



Size	13 O-ring	14 Torque wrench	14a Adapter	22 Compression spring		
C3	5641 001-22	BT-TK-02	5680 035-05	5561 001-71		
C4	3671 010-114	C-TK-01	5680 035-06	5561 001-41		
C5	3671 010-114	C-TK-01	5680 035-07	5561 001-41		
C6	3671 010-119	C-TK-01	5680 035-07	5561 001-41		
C8	3671 010-119	C-TK-02	5680 035-07	5561 001-41		

Draw bar set

Parts included in draw bar set











Size	15 Draw bar set	16 Spiral retaining ring	17 Holder ring (set of 2)	18 Segment (set of 6)	19 O-ring	20 Flat wire spring	21 O-ring
C3	5461 100-101	5545 039-01	5546 001-16	5549 120-08	5641 005-01	5561 015-02	5641 005-15
C4	5461 100-111	5545 039-03	5546 001-20	5549 120-06	5641 005-05	5561 015-03	5641 005-19
C5	5461 100-121	5545 039-02	5546 001-17	5549 120-07	5641 005-06	5561 015-04	5641 005-16
C6	5461 100-131	5545 039-04	5546 001-18	5549 120-04	5641 005-04	5561 015-05	5641 005-17
C8	5461 100-141	5545 039-05	5546 001-19	5549 120-05	5641 005-07	5561 015-06	5641 005-18

Hoses, Part No. ordering code includes spare parts

Connection type	Part No.	Length (mm)
Straight fitting 	JET-HOSE150SS	150
	JET-HOSE200SS	200
	JET-HOSE250SS	250
	JET-HOSE300SS	300
Banjo fitting 	JET-HOSE150BS	150
	JET-HOSE200BS	200
	JET-HOSE250BS	250
	JET-HOSE300BS	300
Banjo-to-Banjo fitting 	JET-HOSE150BB	150
	JET-HOSE200BB	200
	JET-HOSE250BB	250
	JET-HOSE300BB	300

All hoses are pressure rated to a maximum of 275 bar (3990 psi)
Please check availability in current price and stock-list

Spare Parts, Parts included in delivery

Part No.		...SS	...BS	...BB
JET-CFP1/8BSP		■	■	■
JET-CBP15		■	■	■
JET-AD1/8BSP		■	■	
JET-ADM10		■		
JET-BBM10			■	■
JET-BB1/8BSP			■	■
JET-C1/4-1/8BSP			■	■
JET-P1/8-5mm		■	■	■
JET-WM10*		■	■	■
JET-ORING10X1**		■	■	■

Pack of 2, except *Pack of 20

**Not suitable for use in inducer

For assembly instructions, see page(s) 29

Torque wrench

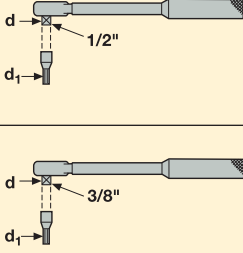

Size	Nm	Part No.	Spare Parts		
			Adapter*	d	d ₁
C3	35	BT-TK-02	5680 035-05	3/8"	8
C4	50	C-TK-01	5680 035-06	1/2"	10
C5	70	C-TK-01	5680 035-07	1/2"	12
C6	90	C-TK-01	5680 035-07	1/2"	12
C8	130	C-TK-02	5680 035-07	1/2"	12

*To be ordered separately

Sliding hammer for dismantling the polygon socket

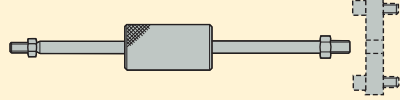

Size	Part No.
C3	CC-ET-01
C4	CC-ET-01
C5	CC-ET-02
C6	CC-ET-02
C8	CC-ET-02

Tool for dismantling the polygon socket on manual clamping unit

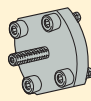

Size	Part No.	Spare Parts	
		Centre	Periphery
C3	C3-WDT-01M	3214 030-463	5512 040-03
C4	C4-WDT-01M	3214 030-464	5512 040-04
C5	C5-WDT-01M	3214 030-516	5512 040-05
C6	C6-WDT-01M	3214 030-516	5512 040-06
C8	C8-WDT-01	3214 030-516	5512 072-01

Grease nipple



Size	Part No.
C3	5692 012-01
C4	5692 012-01
C5	5692 012-01
C6	5692 012-01
C8	5692 012-01

Cover plug



Size	Part No.	
	Type 3000	Other types
C3	C3-CP-11	C3-CP-01
C4	C4-CP-11	C4-CP-01
C5	C5-CP-11	C5-CP-01
C6	-	C6-CP-01
C8	-	C8-CP-01

Torque values for clamping screws

Torque value for each screw is shown below

Screw designation	Torque Nm	Torque key
110.26-655	10,0	–
117.26-655	4,0	–
117.26-657	3,0	H00-2530
170.26-655	6,0	H00T-4060
C02205-T07P	0,9	T00-07P09
C02505-T07P	0,9	T00-07P09
C02506-T07P	0,9	T00-07P09
C03007-T09P	2,0	T00-09P20
C03508-T15P	3,0	T00-15P30
C03509-T15P	3,0	T00-15P30
C03510-T15P	3,0	T00-15P30
C03511-T09P	3,0	–
C03512-T15P	3,0	T00-15P30
C04008-T15P	3,5	T00-15P35
C04010-T15P	3,5	T00-15P35
C04011-T15P	3,5	T00-15P35
C04014-T15P	3,5	T00-15P35
C04512-T15P	5,0	T00-15P50
C04518-T15P	5,0	T00-15P50
C05010-T20P	5,0	T00-20P50
C05012-T15P	5,0	T00-15P50
C05013-T20P	5,0	T00-20P50
C05018-T20P	5,0	T00-20P50
C11804-T06P	0,5	T00-06P05
C46017-T20P	6,0	T00T-20P60
C82204-T06P	0,5	T00-06P05
CC05	0,9	H00-1509
CC08P-V13	2,0	T00-09P20
CC09P-D11	2,0	T00-09P20
CC12P-S12	3,5	T00-15P35
CC14	6,0	H00T-4060
CC16	10,0	–
CC17P	10,0	–
CC17P-06	10,0	–
CC17P-09	10,0	–
CC20P	10,0	–
CC20P-V13	10,0	–
CD09-S09	2,0	T00-09P20
CD12-S12	3,5	T00-15P35
CD16-C16	5,0	T00-20P50
CD19-S19	5,0	T00-20P50
CD19-V16	5,0	T00-20P50
CSC8015-T20P	5,0	T00-20P50
CSC1015-T20P	5,0	T00-20P50
CSP16-T15P	2,0	T00-15P20
CSP22-T25P	3,0	T00-15P30
CSP27-T25P	6,0	T00T-25P60

Screw designation	Torque Nm	Torque key
L84017-T09P	2,0	T00-09P20
L85011-T15P	5,0	T00-15P50
L85017-T09P	2,0	T00-09P20
L85020-T15P	4,0	–
L86025-T20P	6,5	–
LD1035-T25P	6,0	T00T-25P60
LD5020-T09P	2,0	T00-09P20
LD6020-T15P	3,0	T00-15P30
LD6021-T09P	2,0	T00-09P20
LD6024-T20P	2,0	–
LD6025-T15P	3,0	T00-15P30
LD6026-T09P	2,0	T00-09P20
LD8025-T25P	6,0	T00T-25P60
LD8030-T25P	6,0	T00T-25P60
LS0512	2,5	–
LS0613	3,0	H00-2530
LS0616	3,0	H00-2530
LS0818	4,0	–
LS0822	4,0	–
MC6S4X14	3,5	–
MC6S4X18	3,5	–
MC6S5X14	5,0	H00T-4050
MC6S5X18	5,0	H00T-4050
MN0909L-T09P	2,0	T00-09P20
MN1215L-T15P	3,0	T00-15P30
MN1215R-T15P	3,0	T00-15P30
MN1215S-T15P	3,0	T00-15P30
MN1215T-T15P	3,0	T00-15P30
MN1515-T15P	3,0	T00-15P30
MN1515SL-T15P	3,0	T00-15P30
MN1520-T20P	6,0	T00T-20P60
MN1920-T20P	6,0	T00T-20P60
MN1925-T25P	5,0	T00T-25P50
MN2525-T25P	6,0	T00T-25P60
PL1403-T09P	2,5	T00-09P20
TCEI0409	3,5	–
TCEI0509	6,0	H00T-4060
TCEI0513	6,0	H00T-4060
TCEI0609	8,0	H00T-5080
TCEI0613	8,0	H00T-5080
TCEI0614	8,0	H00T-5080
TCEI0620	8,0	H00T-5080
TCEI0815	10,0	H00T-60100
TCEI0825	10,0	H00T-60100
TCEI1020	15,0	–
WS1620-T20P	3,5	T00-20P35
WS1920-T20P	3,5	T00-20P35
WS2325-T25P	5,0	T00T-25P50

For the Seco range of torque keys, please see next page.

Torque key range

The range of torque keys with fixed torque values are available, in combinations key grip/torque value for insert locking, for most of the Seco turning products.

By using a torque key you always ensure the correct tightening force when mounting the insert. The torque value is given on page(s) 686 for each screw.

Torque keys are calibrated according to ISO 6789.

Code key: T00-15P35

T00 = Torque screwdriver type for Torx Plus blade



T00T = Torque T-handle type for Torx Plus blade

H00 = Torque screwdriver for hexagonal blade



H00T = Torque T-handle type for hexagonal blade

15P = Torx Plus size



35 = Torque value 3,5 Nm

Torque key*	Replaceable blade	Torque Plus size	Torque value
			
T00-06P05	T00-06P	T06P	0,5 Nm
T00-07P05	T00-07P	T07P	0,5 Nm
T00-07P09	T00-07P	T07P	0,9 Nm
T00-08P12	T00-08P	T08P	1,2 Nm
T00-09P09	T00-09P	T09P	0,9 Nm
T00-09P12	T00-09P	T09P	1,2 Nm
T00-09P20	T00-09P	T09P	2,0 Nm
T00-10P20	T00-10P	T10P	2,0 Nm
T00-10P30	T00-10P	T10P	3,0 Nm
T00-15P20	T00-15P	T15P	2,0 Nm
T00-15P30	T00-15P	T15P	3,0 Nm
T00-15P35	T00-15P	T15P	3,5 Nm
T00-15P50	T00-15P	T15P	5,0 Nm
T00-20P35	T00-20P	T20P	3,5 Nm
T00-20P50	T00-20P	T20P	5,0 Nm



*Including blade

Torque key*	Replaceable blade	Torque Plus size	Torque value
			
T00T-15P50	T00T-15P	T15P	5,0 Nm
T00T-20P50	T00T-20P	T20P	5,0 Nm
T00T-20P60	T00T-20P	T20P	6,0 Nm
T00T-20P80	T00T-20P	T20P	8,0 Nm
T00T-25P50	T00T-25P	T25P	5,0 Nm
T00T-25P60	T00T-25P	T25P	6,0 Nm
T00T-25P80	T00T-25P	T25P	8,0 Nm
T00T-30P80	T00T-30P	T30P	8,0 Nm

*Including blade

Torque key*	Replaceable blade	Hexagonal size	Torque value
			
H00-1305	H00-1.3	1,3 mm	0,5 Nm
H00-1505	H00-1.5	1,5 mm	0,5 Nm
H00-1509	H00-1.5	1,5 mm	0,9 Nm
H00-2009	H00-2.0	2,0 mm	0,9 Nm
H00-2016	H00-2.0	2,0 mm	1,6 Nm
H00-2020	H00-2.0	2,0 mm	2,0 Nm
H00-2512	H00-2.5	2,5 mm	1,2 Nm
H00-2530	H00-2.5	2,5 mm	3,0 Nm
H00-2535	H00-2.5	2,5 mm	3,5 Nm
H00-3020	H00-3.0	3,0 mm	2,0 Nm
H00-4030	H00-4.0	4,0 mm	3,0 Nm

*Including blade

Torque key*	Replaceable blade	Hexagonal size	Torque value
			
H00T-3050	H00T-3.0	3 mm	5,0 Nm
H00T-4050	H00T-4.0	4 mm	5,0 Nm
H00T-4060	H00T-4.0	4 mm	6,0 Nm
H00T-5080	H00T-5.0	5 mm	8,0 Nm
H00T-60100	H00T-6.0	6 mm	10,0 Nm

*Including blade

Please observe that the blades are not interchangeable between screwdriver type and T-handle type.

Torx Plus® is a registered trade mark belonging to Camcar-Textron (USA)

SMG version 2 – Introduction

The foundation for SMG v2 is a classification of workpiece materials based on their type rather than their relative machinability and consequently it contains workpiece materials like composites. It is comprehensive enough, but still easy to identify which SMG a particular material belongs.

Each SMG has a specific material standard in a specific condition assigned as reference to allow easy adjustment of cutting data for any actual material compared to any Seco reference material see page(s) 49.

As example the reference materials EN C45E for SMG P4 and EN 42 CrMo 4 for both SMG P5 and SMG H5 see further details in the following tables.

Steels, ferritic and martensitic stainless steels

SMG	Description	Properties	Reference
P1	Free-cutting steels	$360 < R_m < 880$	11 SMn30 $R_m = 385 \text{ N/mm}^2$
P2	Low alloy ferritic steels, $C < 0.25\% \text{wt}$ Low alloy weldable general structural steels	$320 < R_m < 600$	S235JRG2 $R_m = 420 \text{ N/mm}^2$
P3	Ferritic & ferritic/pearlitic steels, $C < 0.25\% \text{wt}$ Weldable general structural steels Case hardening steels	$430 < R_m < 610$	16 MnCr 5 $R_m = 550 \text{ N/mm}^2$
P4	Low alloy general structural steels, $0.25\% < C < 0.67\% \text{wt}$ Low alloy Quench & Temper steels	$520 < R_m < 1200$	C 45E $R_m = 660 \text{ N/mm}^2$
P5	Structural steels, $0.25\% < C < 0.67\% \text{wt}$ Quench & Temper steels	$550 < R_m < 1200$	42 CrMo 4 $R_m = 700 \text{ N/mm}^2$
P6	Low alloy through hardening steels, $C > 0.67\% \text{wt}$ Low alloy spring and bearing steels	$520 < R_m < 1200$	C 100S $R_m = 600 \text{ N/mm}^2$
P7	Through hardening steels, $C > 0.67\% \text{wt}$ Spring and bearing steels	$600 < R_m < 1200$	100 Cr 6 $R_m = 650 \text{ N/mm}^2$
P8	Tool steels High Speed Steels (HSS)	$600 < R_m < 1200$	X 40 CrMoV 5 1 $R_m = 700 \text{ N/mm}^2$
P11	Ferritic & martensitic stainless steels	$415 < R_m < 1200$	X 20 Cr 13 $R_m = 675 \text{ N/mm}^2$

Free-cutting, austenitic and duplex stainless steels

SMG	Description	Properties	Reference
M1	Free-cutting austenitic stainless steels		X 10 CrNiS 18 9
M2	Low alloy austenitic stainless steels		X 5 CrNi 18 9
M3	Medium alloy austenitic stainless steels		X 2 CrNiMo 18 14 3
M4	High alloy austenitic and duplex stainless steels		X 2 CrNiMoN 22 5 3
M5	Difficult high alloy austenitic and duplex stainless steels		X 2 CrNiMoN 25 7 4

Cast irons

SMG	Description	Properties	Reference
K1	Grey cast irons (GCI)		EN-GJL-250
K2	Compacted graphite irons (CGI)		EN-GJV-400
K3	Malleable cast irons (MCI)		EN-GJMB-550-4
K4	Nodular cast irons (SGI)		EN-GJS-500-7
K5	Austempered ductile irons (ADI)		EN-GJS-1000-5
K6	Austenitic lamellar cast irons		EN-GJLA-XNiCuCr15-6-2
K7	Austenitic nodular cast irons		EN-GJSA-XNiMn23-4

Non-ferrous metals

SMG	Description	Properties	Reference
N1	Aluminum alloys, Si < 9%		AW-7075
N2	Aluminum alloys, 9% < Si < 16%		AC-44200 Si = 12%
N3	Aluminum alloys, Si > 16%		AlSi17Cu5
N11	Copper alloys		CW614N

Superalloys and titanium

SMG	Description	Properties	Reference
S1	Iron based superalloys		Disalloy
S2	Cobalt based superalloys		Stellite 21
S3	Nickel based superalloys		Inconel 718
S11	Titanium, low alloyed, (α)		Ti
S12	Titanium, medium alloyed, ($\alpha+\beta$)		TiAl6V4
S13	Titanium, high alloyed, (near β and β)		Ti10V2Fe3Al

Hard materials

SMG	Description	Properties	Reference
H3	Case hardened steels	58 < HRC < 62	16 MnCr 5 60 HRC
H5	Quenched & Tempered steels	38 < HRC < 56	42 CrMo 4 50 HRC
H7	Quenched & Tempered steels Bearing steels	56 < HRC < 64	100 Cr 6 60 HRC
H8	Tool steels High Speed Steels	38 < HRC < 64	X 40 CrMoV 5 1 50 HRC
H11	Martensitic stainless steels	38 < HRC < 50	X 20 Cr 13 45 HRC
H12	Precipitation hardened stainless steels	33 < HRC < 50	X 5 CrNiCuNb 16 4 35 HRC
H21	Manganese steels	23 < HRC < 64	X 120 Mn 12 50 HRC
H31	White cast irons	50 < HRC < 64	EN-GJN-HV600(XCr11) 55 HRC

Other difficult materials

SMG	Description	Properties	Reference
PM1	Low alloy PM materials		F-0008 Fe-0.7C
PM2	Medium alloy PM materials		FLC-4608 Fe2Cu1.8Ni0.5Mo0.2Mn0.8C
PM3	High alloy PM materials Exhaust valve seat materials		
HF1	Hard facing alloys Welded or plasma deposited iron based alloys		
HF2	Hard facing alloys Welded or plasma deposited cobalt and nickel based alloys		
CC1	Sintered tungsten carbide		G50

Plastics and Composites

SMG	Description	Properties	Reference
TS1	Thermosetting polymers		Urea formaldehyde (UF)
TS2	Thermosetting Carbon fiber composites		T300 T700 T800 HTA-S IMA - Epoxy (M21)...
TS3	Thermosetting Glass fiber composites		Epoxy - HX..(42..)/E glass (7781...)...
TS4	Thermosetting Aramide fibre composites		Kevlar 49
TP1	Thermoplastic polymers		Polycarbonate (PC)
TP2	Thermoplastic Carbon fiber composites		PPS/PEEK - T300..
TP3	Thermoplastic Glass fiber composites		PPS/PEEK - E glass or A glass...
TP4	Thermoplastic Aramide fibre composites		

Graphite

SMG	Description	Properties	Reference
GR1	Graphite		R 8500

SMG

SMG	EN	EN-Nr	W.-Nr	DIN	AFNOR	BS	UNI	JIS	SS	UNS
P1	11 SMn30	1.0715	1.0715	9 SMn 28	S 250	230 M 07	CF 9 SMn 28	SUM 22	1912	G12130
	11 SMnPb30	1.0718	1.0718	9 SMnPb 28	S 250 Pb		CF 9 SMnPb 28	SUM 22 L	1914	G12134
	10 S 20	1.0721	1.0721	10 S 20	10 F 1	210 M 15	CF 10 S 20			
			1.0722	10 SPb 20	10 PbF 2		CF 10 SPb 20			
	15 SMn13	1.0725	1.0723	15 S 20		210 A 15		SUM 32	1922	
	35 S20	1.0726	1.0726	35 S 20	35 MF 4	212 M 36			1957	G11400
	46 S20	1.0727	1.0727	46 S 20	45 MF 4	212 M 44			1973	G11460
	11 SMn37	1.0736	1.0736	9 SMn 36	S 300	240 M 07	CF 9 SMn 36			G12150
	11 SMnPb 37	1.0737	1.0737	9 SMnPb 36	S 300 Pb		CF 9 SMnPb 36		1926	G12144
	S235JR	1.0037	1.0037	St 37-2	E 24-2		Fe 360 B	STKM 12 C	1311	
	S235JRG2	1.0038	1.0116	St 37-3	E 24-3, E 24-4	4360-40 C	Fe 360 D FF		1312, 1313	
S275J2G3	1.0144	1.0144	St 44-3 N	E 28-3, E 28-4	4360-43 C	Fe 430 D FF	SM 41 C	1412, 1414		
C 10	1.0301	1.0301	C 10	AF 34 C 10, XC 10	045 M 10	C 10	S 10 C		G10100	
		1.0401	C 15	AF3 7 C 12, XC 18	080 M 15	C 15, C 16		1350	G10170	
C22+N	1.0402	1.0402	C 22	C 20	050 A 20	C 20, C 21		1450	G10200	
S355JR	1.0570	1.0570	St 52-3	E 36-3, E 36-4	4360-50 C	Fe 510 B	SM 50 YA	2172, 2132		
C 15R	1.1141	1.1141	Ck 15	XC 15, XC 18	080 M 15	C 15, C 16	S 15 C, S 15 CK	1370	G10170	
		1.1158	Ck 25	XC 25	060 A 25	C 25	S 25 C		G10250	
		1.2162	21 MnCr 5	20 NC 5			SCR 420 H			
16 Mo 3	1.5415	1.5415	15 Mo 3	15 D 3	1501-240	16 Mo 3		2912		
		1.5423	16 Mo 5		1503-245-420	16 Mo 5	SB 450 M		G45200	
14 NiCr 14	1.5752	1.5752	14 NiCr 14	12 NC 15	655 M 13		SNC 815 (H)		G33106	
		1.5919	15 CrNi 6	16 NC 6	S 107	16 CrNi 4				
18 NiCrMo 7 6	1.6587	1.6587	18 CrNiMo 7 6	18 NCD 6	820 A 16	18 NiCrMo 7				
16 MnCr 5	1.7131	1.7131	16 MnCr 5	16 MC 5	527 M 17	16 MnCr 5	SCR 415	2511	G51170	
16 MnCrS 5	1.7139	1.7139	16 MnCrS 5							
20 MnCr 5	1.7147	1.7147	20 MnCr 5	20 MC 5		20 MnCr 5	SMnC 420 (H)		G51200	
20 MnCrS 5	1.7149	1.7149	20 MnCrS 5	20 MnCrS 5			SMnC 21 H			
13 CrMo 4 5	1.7335	1.7335	13 CrMo 4 4	15 CD 3,5	1501-620 Gr. 27	14 CrMo 4 5		2216		
		1.7337	16 CrMo 4 4	15 CD 4,5	1501-620 Gr. 27	14 CrMo 4 5		2216		
10 CrMo 9 10	1.7380	1.7380	10 CrMo 9 10	10 CD 9,10	1501-622 Gr. 31	12 CrMo 9 10		2218	J21890	
C35+N		1.0501	C 35	AF 55 C 35	060 A 35	C 35		1550	G10350	
E 335	1.0503	1.0503	C 45	AF 65 C 45	80 M 46	C 45	S 45 C	1650	G10430	
C40+N		1.0511	C 40	AF 60 C 40	080 M 40	C 40	S 40 C			
E 360	1.0070	1.0535	St 70-2	A 70-2		Fe 690		1655		
C60+N	1.0601	1.0601	C 60	CC 55	080 A 62	C 60			G10600	
		1.1157	40 Mn 4	35 M 5	150 M 36				G10390	
G 28 Mn6	1.1165	1.1165	30 Mn 5		120 M 36		SMn 1 H, SCMn 2		G13300	
G 28 Mn6+QT	1.1165	1.1167	36 Mn 5	40 M 5	150 M 36		SMn 438 (H), SCMn 3	2120	G13350	
C 35E	1.1181	1.1181	Ck 35	XC 38 H1	080 M 36	C 35	S 35 C	1572	G10340	
C 45E	1.1191	1.1191	Ck 45	XC 42	080 M 46	C 45	S 45 C	1672	G10420	
C 60E	1.1221	1.1221	Ck 60	XC 60	080 A 62	C 60	S 58 C	1665, 1678	G10640	
		1.1740	C 60 W	Y3 55			SK 7			
55 SiCr7	1.7100	1.0904	55 Si 7	55 S 7	250 A 53	55 Si 8		2085, 2090		
42 CrMo 4	1.7225	1.1201	42 CrMo 4	42 CD 4	708 M 40	42 CrMo 4	SCM 440 (H)	2244	G41400	
42 CrMo 4	1.7225	1.1201	42 CrMo 4	42 CD 4	708 M 40	42 CrMo 4	SCM 440 (H)	2244	G41400	
		1.2330	35 CrMo 4	34 CD 4	708 A 37	35 CrMo 4		2234	T51620	
		1.2542	45 WCrV 7		BS 1	45 WCrV 8 KU		2710	T41901	
		1.2714	56 NiCrMoV 7		BH 224-5	56 NiCrMoV7-KU	SKT 4		T61206	
		1.5121	46 MnSi 4							
		1.5710	36 NiCr 6	35 NC 6	640 A 35					
		1.5736	36 NiCr 10	35 NC 11		35 NiCr 9	SNC 631 (H)			
36CrNiMo4+TA	1.6511	1.6511	36 CrNiMo 4	40 NCD 3	816 M 40	38 NiCrMo 4 (KB)			G98400	
34 CrNiMo 6	1.6582	1.6582	34 CrNiMo 6	35 NCD 6	817 M 40	35 NiCrMo 6 (KW)	SNCM 447	2541		
34 Cr 4	1.7033	1.7033	34 Cr 4	32 C 4	530 A 32	34 Cr 4 (KB)	SCR 430 (H)		G51320	
41 Cr 4	1.7035	1.7035	41 Cr 4	42 C 4	530 M 40	41 Cr 4	SCR 440 (H)		G51400	
25 CrMo 4	1.7218	1.7218	25 CrMo 4	25 CD 4 S	708 M 25	25 CrMo 4 (KB)	SCM 425	2225	G41300	
		1.7361	32 CrMo 12	30 CD 12	722 M 24	32 CrMo 12		2240		
50 CrV 4	1.8159	1.8159	50 CrV 4	50 CV 4	735 A 50	51 CrV 4	SUP 10	2230	H61500	
41 CrAlMo 7 10	1.8509	1.8509	41 CrAlMo 7	40 CAD 6.12	905 M 39	41 CrAlMo 7	SACM 645	2940	K24065	
C 67S	1.1231	1.1231	Ck 67	XC 68	060 A 67	C 70		1770	G10700	
C 100S	1.1274	1.1274	Ck 101		060 A 96		SUP 4	1870	G10950	
C 105U	1.1545	1.1545	C 105 W1	Y1 105		C 100 KU		1880		
		1.1645	C 105 W2	Y1 105		C 100 KU	SK 3			
		1.1663	C 125 W	Y2 120		C 120 KU	SK 2			

SMG

U.N.E./I.H.A.	AISI / ASTM	GOST	Misc. Brands	Condition	Structure
	1213			Annealed	
	12 L 13			Annealed	
	1108			Annealed	
	11 L 08			Annealed	
				Annealed	
	1140	40		Annealed	
	1146			Annealed	
	1215			Annealed	
	12 L 14			Annealed	
		16D		Annealed	
	A 573 Gr. 58	18kp		Annealed	
	A 573 Gr. 70	St14kP		Annealed	
	1010	10		Annealed	
F.1110	1015	15		Annealed	
	1023	20		Annealed	
		17G1S		Annealed	
F.1511	1015	15		Annealed	
F.1120	1025	25		Annealed	
				Annealed	
	A 204 Gr. A			Annealed	
	4520			Annealed	
	3310, 9314	20X2H4A		Annealed	
	4320			Annealed	
				Annealed	
F.1516	5115	12KHn2		Annealed	
		18HG		Annealed	
	5120	20KH		Annealed	
	5120 H	20KH		Annealed	
	A 182-F11, F12	12KHM		Annealed	
	A 387 Gr. 12 Cl. 2			Annealed	
F.155	A 182-F22	12KH8		Annealed	
F.1130	1035	35		Annealed	
F.5110	1045	45		Annealed	
	1040	40		Annealed	
F.1150	1055	55		Annealed	
	1060	60		Annealed	
	1039	40G		Annealed	
	1330	30G2		Annealed	
F.411	1335	35G2		Annealed	
F.1135	1035	35		Annealed	
F.1140	1045	45		Annealed	
F.1150	1064	60		Annealed	
	1060	60		Annealed	
F.144	9255	55S2		Annealed	
F.1252	4142, 4140	38HM		Annealed	
F.1252	4142, 4140	38HM		Quenched & Tempered	
F.1250	4135	35KHM		Annealed	
F.5241	S1	5KHV2S		Annealed	
	L6	5KHNV		Annealed	
	5045			Annealed	
	3135			Quenched & Tempered	
	3435			Annealed	
	9840			Quenched & Tempered	
F.1280	4340	38H2N2MA		Annealed	
	5132	35KH		Quenched & Tempered	
	5140	40H		Quenched & Tempered	
F.1251	4130	20KHM		Quenched & Tempered	
				Quenched & Tempered	
F.143	6150	50KHFA		Quenched & Tempered	
F.1740	A 355 Cl. A			Annealed	
F.5103	1070	70		Annealed	
F.5117	1095			Annealed	
F.5118	W1	U10A		Annealed	
		U10		Annealed	
	W1	U13		Annealed	

SMG

SMG	EN	EN-Nr	W.-Nr	DIN	AFNOR	BS	UNI	JIS	SS	UNS	
P7	107 CrV 3	1.2210	1.2210	115 CrV 3	100 C 3		107 CrV 3 KU			T61202	
			1.2510	100 MnCrV 4	90 MWCV 5	BO 1	95 MnWCr 5 KU	SKS 3	2140	T31501	
	90 MnCrV 8	1.2842	1.2842	90 MnCrV 8	90 MV 8	BO 2	90 MnVCr 8 KU			T31502	
	100 Cr 6	1.3505	1.3505	100 Cr 6	100 C 6	534 A 99	100 Cr 6	SUJ 2	2258	G51986	
P8	X 210 Cr 12	1.2080	1.2080	X 210 Cr 12	Z 200 C 12	BD 3	X 210 Cr 13 KU	SKD 1		T30403	
			1.2343	X 38 CrMoV 5 1	Z 38 CDV 5	BH 11	X 37 CrMoV 5 1 KU	SKD 6		T20811	
	X 40 CrMoV 5 1	1.2344	1.2344	X 40 CrMoV 5 1	Z 40 CDV 5	BH 13	X 40 CrMo 5 1 1 KU	SKD 61	2242	T20813	
	X 100 CrMoV 5	1.2363	1.2363	X 100 CrMoV 5 1	Z 100 CDV 5	BA 2	X 100 CrMoV 5 1 KU	SKD 12	2260	T30102	
			1.2365	X 32 CrMoV 3 3	32 DCV 28	BH 10	30 CrMoV 12 27 KU	SKD 7		T20810	
			1.2436	X 210 CrW 12			X 215 CrW 12 1 KU	SKD 2		2312	
			1.2601	X 165 CrMoV 12			X 165 CrMoV 12 KU			2310	
			1.2713	55 NiCrMoV 6	55 NCDV 7			SKT 4			T61206
	HS 6-5-2-5	1.3243	1.3243	S 6-5-2-5	Z 85 WDKCV 06-05-05-04-02		HS 6-5-2-5	SKH 55		2723	
	HS 2-10-1-8	1.3247	1.3247	S 2-10-1-8	Z 110 DKCW 09-08-04	BM 42	HS 2-9-1-8	SKH 51			T11342
	HS 18-1-2-5	1.3255	1.3255	S 18-1-2-5	Z 80 WKCV 18-05-04-01	BT 4	HS 18-1-1-5	SKH 3			T12004
	HS 6-5-2	1.3343	1.3343	S 6-5-2	Z 85 WDCV 06-05-04-02	BM 2	HS 6-5-2	SKH 9, SKH 51	2722		T11302
HS 2-9-2	1.3348	1.3348	S 2-9-2	Z 100 DCWV 09-04-02-02		HS 2-9-2	SKH 58		2782	T11307	
HS 18-0-1	1.3355	1.3355	S 18-0-1	Z 80 WCV 18-04-01	BT 1	HS 18-0-1	SKH 2			T12001	
P11	X 6 Cr 13	1.4000	1.4000	X 6 Cr 13	Z 6 C 12	403 S 17	X 6 Cr 13	SUS 403	2301	S41008	
	X 12 Cr 13	1.4006	1.4006	X 10 Cr 13	Z 10 C 13	410 S 21	X 12 Cr 13	SUS 410	2302	S41000	
	X 6 Cr 17	1.4016	1.4016	X 6 Cr 17	Z 8 C 17	430 S 15	X 8 Cr 17	SUS 430	2320	S43000	
	X 20 Cr 13	1.4021	1.4021	X 20 Cr 13	Z 20 C 13	420 S 37	X 20 Cr 13	SUS 420 J 1	2303	S42000	
	X 39 Cr 13	1.4031	1.4031	X 40 Cr 13	Z 40 C 14	420 S 45	X 40 Cr 14	SUS 420	2304	S40280	
	X 70 CrMo 15	1.4109	1.4109	X 65 CrMo 14	Z 70 D 14			SUS 440 A		S44002	
	X 90 CrMoV 18	1.4112	1.4112	X 90 CrMoV 18	Z 2 CND 18 05	409 S 19	X CrTi 12	SUS 440 B	2327	S44003	
	X 105 CrMo 17	1.4125	1.4125	X 105 CrMo 17	Z 100 CD 17		X 105 CrMo 17	SUS 440 C		S44004	
	X 3 CrNiMo 13 3	1.4313	1.4313	X 5 CrNi 13 4	Z 5 CN 13.4	425 C 11	X 6 CrNi 13 04	SCS 5		2385	J91540
	X 18 CrN 28	1.4749	1.4749	X 18 CrN 28	Z 18 C 25					2322	S44600
M1	X 10 CrNiS 18 9	1.4305	1.4305	X 10 CrNiS 18 9	Z 10 CNF 18.09	303 S 31	X 10 CrNi 18 09	SUS 303	2346	S30300	
M2	X 12 CrNi 18 8	1.4300	1.4300	X 12 CrNi 18 8	Z 12 CN 18	302 S 25		SUS 302	2331	S30200	
	X 5 CrNi 18 9	1.4301	1.4301	X 6 CrNi 18 10	Z 6 CN 18.09	304 S 31	X 5 CrNi 18 11	SUS 304	2333	S30400	
	X 2 CrNi 19 11	1.4306	1.4306	X 2 CrNi 19 11	Z 2 CN 18.10	304 S 12	X 3 Cr Ni 18 11	SUS 304 L	2352	S30403	
	X 9 CrNi 18 8	1.4310	1.4310	X 12 CrNi 17 7	Z 12 CN 17.07	301 S 21	X 12 CrNi 17 07	SUS 301		(2331)	S30100
	X 5 CrNiMo 17 12 2	1.4401	1.4401	X 5 CrNiMo 17 12 2	Z 3 CND 17.11.1	316 S 31	X 5 CrNiMo 17 12	SUS 316	2347	S31600	
	X 6 CrNiNb 18 10	1.4550	1.4550	X 6 CrNiNb 18 10	Z 6 CNNb 18.10	347 S 31	X 6 CrNiNb 18 11	SUS 347	2338	S34700	
M3	X 2 CrNiN 18 10	1.4311	1.4311	X 2 CrNiN 19 11	Z 2 CN 18 10 Az	304 S 62	X 2 CrNiN 18 11	SUS 304 LN	2371	S30453	
	X 12 CrNi 25 21	1.4335	1.4335	X 12 CrNi 25 21	Z 12 CN 25.20	310 S 24	X 6 CrNi 26 20	SUH 310, SUS 310 S	2361	S31008	
	X 2 CrNiMoN 17 13 3	1.4429	1.4429	X 2 CrNiMoN 17 13 3	Z 2 CND 17.13 Az	316 S 62	X 2 CrNiMoN 17 13 3	SUS 316 LN	2375	S31653	
	X 2 CrNiMo 18 14 3	1.4435	1.4435	X 2 CrNiMo 18 14 3	Z 2 CND 17.13	316 S 12	X 2 CrNiMo 17 13 2	SCS 16, SUS 316 L	2353	S31603	
	X 3 CrNiMo 18 12 3	1.4466	1.4466	X 5 CrNi 18 15		317 S 16	X 5 CrNi 18 15	SUS 317	2366	S31700	
X 9 CrNiSiN 21 11 2	1.4835	1.4893	X 9 CrNiSiN 21 11 2		310 S 31				2368	S30815	
M4	X 2 CrNiMoSi 19 5	1.4424	1.4417	X 2 CrNiMoSi 19 5	Z 2 CND 18.05.03					2376	S31500
	X 3 CrNiMo 27 5 2	1.4460	1.4460	X 4 CrNiMo 27 5 2	Z 3 CND 25.7 Az		X 3 CrNiMo 27 5 2	SUS 329 J 1	2324	S32900	
	X 2 CrNiMoN 22 5 3	1.4462	1.4462	X 2 CrNiMoN 22 5	Z 2 CND 22.05 Az	332 S 15	X 2 CrNiMoN 22 5		2377	S31803	
	X 2 NiCrMoCu 25 20 5	1.4539	1.4539	X 2 NiCrMoCu 25 20 5	Z 2 NCDU 25 20	904 S 13			2562	N08904	
M5	X 2 CrNiMoN 25 7 4	1.4410	1.4410	X 2 CrNiMoN 25 7 4	Z 3 CND 25.07 Az		X 2 CrNiMoN 25 7 4		2328	S32750	
	X 1 CrNiMoN 20 18 7	1.4547	1.4529	X 1 CrNiMoN 20 18 7	Z 1 CNDU 20.18.05 Az		X 1 CrNiMoN 20 18 7		2778	S31254	
	X 6 NiCrTiMoV 25 15	1.4534	1.4534	X 3 CrNiMoAl 13 8 2						S13800	
		1.4540	1.4540	X 4 CrNiCuNb 16 4	Z 4 CNUNb 16.4 M						S15500
	X 3 CrNiMoAl 13 8 2	1.4568	1.4568	X 7 CrNiAl 17 7	Z 9 CAN 17.7	301 S 81	X 7 CrNiAl 17 7	SUS 631	2388	S17700	
	X 1 CrNiMoN 25 22 8	1.4652	1.4652	X 2 CrNiMoN 25 22 7							S32654
X 10 NiCrAlTi 32 20	1.4876	1.4876	X 10 NiCrAlTi 32 20	Z 10 NC 32.21			NCF 800			N08800	
X 5 CrNiCuNb 16 4	1.4980	1.4943	X 4 NiCrTi 25 15	Z 6 NCTDV 25.15	HR 51		SUH 660	2570		S66286	

SMG

U.N.E./ I.H.A.	AISI / ASTM	GOST	Misc. Brands	Condition	Structure
F.520L	L2	11KHf		Annealed	
F.5220	O1	9KHVG		Annealed	
	O2	9G2F		Annealed	
F.5230	52100	SHKH15		Annealed	
F.5212	D3	KH12		Annealed	
	H11	4KH5MFS		Annealed	
F.5318	H13	4KH5MF1S		Annealed	
F.5227	A2	9KH5VF		Annealed	
	H10	3KH3M3F		Annealed	
F.5213		KH12		Annealed	
		KH12MF		Annealed	
F.520.S	L6	5KHNM		Annealed	
F.5613	M35	R6M5K5		Annealed	
	M42	R2AM9K5		Annealed	
	T4	R18K5F2		Annealed	
F.5603	M2	R6M5		Annealed	
	M7			Annealed	
	T1	R18		Annealed	
	403	08KH13		Annealed	Ferrite
F.3401	410, CA-15	12KH13, 08KH13		Annealed	Martensite
F.3113	430	12KH17		Annealed	Ferrite
F.5261	420	20KH13		Annealed	Martensite
F.3404	420	40KH13		Annealed	Martensite
	440 A			Annealed	Martensite
	440 B	95KH18		Annealed	Martensite
	440 C	95KH18		Annealed	Martensite
			F6NM	Annealed	Martensite
	446	15KH28		Annealed	Ferrite
F.3508	303	12KH19N9		Annealed	Austenite
	302	12KH18N9		Annealed	Austenite
F.3504	304, 304 H	08KH18N10		Annealed	Austenite
F.3504	304 L	03KH18N11		Annealed	Austenite
F.3517	301	07KH16N6		Annealed	Austenite
F.3534	316	08KH17H13M2T		Annealed	Austenite
F.3524	347	08KH18N12B		Annealed	Austenite
F.3541	304 LN	03KH18N11		Annealed	Austenite
	310 S	12KH25N20		Annealed	Austenite
	316 LN	03KH16N15M3		Annealed	Austenite
F.3533	316 L	03KH17N14M3		Annealed	Austenite
	317	08KH17H15M3T		Annealed	Austenite
			253 MA	Annealed	Austenite
			3RE60	Annealed	Duplex
	329			Annealed	Duplex
	329 LN		SAF 2205	Annealed	Duplex
	904L			Annealed	Super austenite
	F 53		SAF 2507	Annealed	Super duplex
			254 SMO	Annealed	Super austenite
	XM-13		PH13-8Mo	Solution treated	Austenite
	XM-12		15-5-PH	Solution treated	Martensite
	AMS 5528	09KH17N7YU1		Solution treated	Austenite/ferrite
			654 SMO	Annealed	Super austenite
			Alloy 800	Annealed	Austenite
	660		A286	Solution treated	Austenite

SMG

SMG	EN	EN-Nr	W.-Nr	DIN	AFNOR	BS	UNI	JIS	SS	UNS
K1	EN-GJL-150	0.6150	0.6150	GG-15	Fl 15 D	Grade 150	G15	FC 150	01 15-00	F11601
	EN-GJL-200	0.6200	0.6200	GG-20	Fl 20 D	Grade 220	G20	FC 200	01 20-00	F12101
	EN-GJL-215			GG-220 HB					02 19	
	EN-GJL-250	0.6250	0.6250	GG-25	Fl 25 D	Grade 260	G25	FC 250	01 25-00	F12401
	EN-GJL-300	0.6300	0.6300	GG-30	Fl 30 D	Grade 300	G30	FC 300	01 30-00	F13101
EN-GJL-350	0.6350	0.6350	GG-35	Fl 35 D	Grade 350	G35	FC 350	01 35-00	F13502	
K2	EN-GJV-300			GJV-300						
	EN-GJV-350			GJV-350						
	EN-GJV-400			GJV-400						
	EN-GJV-450			GJV-450						
EN-GJV-500			GJV-500							
K3	EN-GJMB-550-4	0.8155		GTS-55-04	P 540/5	P 540/5	P 55-04	PCMP55-04	08 54-00	F24130
K4	EN-GJS-350-22	0.7033	0.7033	GGG-35.3	FGS 370-17	Grade 350/22		FCD 350-22L	07 17-15	
	EN-GJS-400-15	0.7040	0.7040	GGG-40	FGS 400-12	Grade 420/12	GS 400-12	FCD 400-18L	07 17-02	F32800
	EN-GJS-400-18	0.7043	0.7043	GGG-40.3	FGS 370-17	Grade 370/17	GSO 42/17		07 17-12	F32800
	EN-GJS-500-7	0.7050	0.7050	GGG-50	FGS 500-7	Grade 500/7	GS 500-7	FCD 500-7	07 27-02	F33800
	EN-GJS-600-3	0.7060	0.7060	GGG-60	FGS 600-3	Grade 600/3	GS 600-3	FCD 600-3	07 32-03	F34100
	EN-GJS-700-2	0.7070	0.7070	GGG-70	FGS 700-2	Grade 700/2	GS 700-2	FCD 700-2	07 37-01	F34800
K5	-									ADI grade 5
	EN-GJS-1000-5			GJS-1000-5						ADI grade 2
	EN-GJS-1200-2			GJS-1200-2						ADI grade 3
	EN-GJS-1400-1			GJS-1400-1						ADI grade 4
EN-GJS-800-8			GJS-800-8						ADI grade 1	
K6	EN-GJLA-XNiCr 20-2	0.6660	0.6660	GGL-NiCr 20 2	FGL N20 Cr2	Grade F2			05 23-00	F41002
	EN-GJLA-XNiCr 30-3	0.6676	0.6676	GGL-NiCr 30 3	FGL N30 Cr3	Grade F3				F41004
	EN-GJLA-XNiCuCr15-6-2	0.6655	0.6655	GGL-NiCuCr 15 6 2	FGL Ni15 Cu6 Cr2	Grade F1				F41000
K7	EN-GJSA-XNi35	0.7683	0.7683	GGG-Ni 35	FGS Ni35					F43006
	EN-GJSA-XNiCr20-2	0.7660	0.7660	GGG-NiCr 20 2	FGS N20 Cr2	Grade S2				F43000
	EN-GJSA-XNiCr30-3	0.7676	0.7676	GGG-NiCr 30 3	FGS N30 Cr3	Grade S3				F43003
	EN-GJSA-XNiMn13-7	0.7652	0.7652	GGG-NiMn 13 7	FGS Ni13 Mn7	Grade S6			07 72-00	-
	EN-GJSA-XNiMn23-4	0.7673	0.7673	GGG-NiMn 23 4	FGS Ni23 Mn4	Grade S2M				F43010
N1	AW-1050A	Al99.5	3.0255	Al99.5	A-5/1050A	1B		(A1050)	4007	AA1050A
	AW-3103	AlMn1	3.0515	AlMn1		N3			4054	AA3103
	AW-3003	AlMn1Cu	3.0517	AlMn1Cu	A-M1/3003			A3003		AA3003
	AW-2014	AlCuSiMn	3.1255	AlCuSiMn	A-U4SG/2014	H15			4338	AA2014
	AW-2011	AlCuBiPb	3.1655	AlCuBiPb	A-USPbBi/2011	FC1		A2011	4355	AA2011
	AC-46200	AlSi8Cu3(Si)	3.2161	G-AlSi8Cu3					4251	A13800
	AC-42000		3.2341	G-AlSi6Mg	A-S7G	LM25	3599	AC 4C	4244	
	AW-6060	AlMgSi0.5	3.3206	AlMgSi0.5	A-GS/6060	(H9)			4103	AA6060
	AW-6063	AlMgSi0.7	3.3210	AlMgSi0.7	A-GSUC/6061	(H10)		(A6063)	4104,4107	AA6005
	AW-5005	AlMg1	3.3315	AlMg1	A-G0.6	N41			4106	AA5005
	AW-7020	AlZn4.5Mg1	3.4335	AlZn4.5Mg1	A-Z5G/7020	H17			4425	AA7020
	AW-7075		3.4365	AlZnMgCu1.5	A-Z5GJ/7075	2L95/2L96		A7075		AA7075
	MN65120	MgSe3Zn2Zr1	3.5103	G-MgSe3Zn2Zr1	ZRE1	MAG6-TE				M12330
	MG-P-63	MgAl6Zn	3.5612	G-MgAl6Zn	G-A6-Z1	MAG-E-121				M11600
	MG-P-61	MgAl8Zn	3.5812	G-MgAl8Zn	(G-A7-Z1)					
	N2	AW-6082	AlMgSi1	3.2315	AlMgSi1	A-SGM0.7/6082	H30			4212
AC-43400		AlSi10Mg(Fe)	3.2381	G-AlSi10Mg	A-S10G	LM9			4253	A13600
AC-44200		AlSi12	3.2382	GD-AlSi12						
N3		AlSi17Cu5						ADC14		
N11	CC331G		2.0940.01	CuAl10Fe	CuAl10Fe	AB1			5710	C95200
	CC333G		2.0975.01	CuAl10Ni	CuAl10Ni5Fe5	AB2			5716	C95500
			2.0872	CuNi10Fe1Mn	CuNi10Fe1Mn	CN102			5667	C70600
				CuNi10Zn45						
			2.0790	CuNi18Zn19Pb	CuNi18Zn19Pb1					C76300
	CW352H		2.1176	CuPb10Sn	CuSn10Pb10	LB2			5640	C93700
	CC480K		2.1050.01	CuSn10	CuSn10	CT1			5443	C90700
			2.1087	CuSn10Zn					5458	C90500
	CW452K	CuSn6	2.1020	CuSn6	CuSn6	PB103		C5191	5428	C51900
	CW502L	CuZn15	2.0240	CuZn15	CuZn15	CZ102		C2300	5112	C23000
	CW706R	CuZn28Sn1	2.0470	CuZn28Sn1	CuZn29Sn1				5220	C44300
	CW508L	CuZn37	2.0321	CuZn37			CZ108		5150	C27200
	CW717R	CuZn38Sn1	2.0530	CuZn38Sn1						C46400
	CW614N	CuZn39Pb3	2.0401	CuZn39Pb3	CuZn39Pb3	CZ121			5170	C38500
	CW612N	CuZn40Pb2	2.0402	CuZn40Pb2	CuZn39Pb2	CZ120			5168	C37800
	CW622N	CuZn44Pb2	2.0410	CuZn44Pb2		CZ104			5272	C68700

SMG

SMG	EN	EN-Nr	W-Nr	DIN	AFNOR	BS	UNI	JIS	SS	UNS	
S1											
S2											
S3	NiMo30		2.4810							N10002	
	NiMo16Cr15W		2.4819							N10276	
	NiCr19Fe19Nb5Mo3		2.4668							N07718	
			2.4669							N07750	
	NiCr20TiAl		2.4631							N07080	
	NiCr19Co18Mo4Ti3Al3									N07500	
			2.4654							N07001	
			3.7024								
S11										R54620	
										R56320	
S12	TiAl6V4		3.7164							R56400	
S13				TiV10Fe2Al3							
H3	16 MnCr 5	1.7131	1.7131	16 MnCr 5	16 MC 5	527 M 17	16 MnCr5	SCR 415	2511	G51170	
H5	42 CrMo 4	1.7225	1.1201	42 CrMo 4	42 CD 4	708 M40	42 CrMo 4	SCM 440 (H)	2244	G41400	
	C 67S	1.1231	1.1231	Ck 67	XC 68	060 A 67	C 70		1770	G10700	
	C 75S	1.1248	1.1248	Ck 75	XC 75	060 A 78	C 75		1774, 1778	G10780	
	C 100S	1.1274	1.1274	Ck 101		060 A 96		SUP 4	1870	G10950	
	C 105U	1.1545	1.1545	C 105 W1	Y1 105				1880		
			1.2550	60 WCrV 7	55 WC 20			55 WCrV 8 KU			
55 Cr 3	1.7176	1.7176	55 Cr 3	55 C 3	527 A 60	55 Cr 3	SUP 9 (A)	2253	G51550		
H7	107 CrV 3	1.2210	1.2210	115 CrV 3	100 C 3		107 CrV 3 KU			T61202	
			1.2510	100 MnCrW 4	90 MWCV 5	BO 1	95 MnWCr 5 KU	SKS 3	2140	T31501	
	90 MnCrV 8	1.2842	1.2842	90 MnCrV 8	90 MV 8	BO 2	90 MnVCr 8 KU			T31502	
100 Cr 6	1.3505	1.3505	100 Cr 6	100 C 6	534 A 99	100 Cr 6	SUJ 2	2258	G51986		
H8	X 40 CrMoV 5 1	1.2344	1.2344	X 40 CrMoV 5 1	Z 40 CDV 5	BH 13	X 40 CrMo 5 1 1 KU	SKD 61	2242	T20813	
	X 100 CrMoV 5	1.2363	1.2363	X 100 CrMoV 5 1	Z 100 CDV 5	BA 2	X 100 CrMoV 5 1 KU	SKD 12	2260	T30102	
	X 155 CrVMo 12 1		1.2379	X 155 CrVMo 12 1	Z 160 CDV 12	BD 2	X 155 CrVMo 12 1 KU	SKD 11		T30402	
			1.2436	X 210 CrW 12			X 215 CrW 12 1 KU	SKD 2		2312	
			1.2601	X 165 CrMoV 12			X 165 CrMoW 12 KU			2310	
			1.2713	55 NiCrMoV 6	55 NCDV 7			SKT 4			T61206
	HS 6-5-2-5	1.3243	1.3243	S 6-5-2-5	Z 85 WDKCV 06-05-05-04-02		HS 6-5-2-5	SKH 55	2723		
	HS 2-10-1-8	1.3247	1.3247	S 2-10-1-8	Z 110 DKCWV 09-08-04	BM 42	HS 2-9-1-8	SKH 51			T11342
	HS 6-5-2	1.3343	1.3343	S 6-5-2	Z 85 WDCV 06-05-04-0	BM 2	HS 6-5-2	SKH 9, SKH 51	2722		T11302
	HS 18-0-1	1.3355	1.3355	S 18-0-1	Z 80 WCV 18-04-01	BT 1	HS 18-0-1	SKH 2			T12001
H11	X 20 Cr 13	1.4021	1.4021	X 20 Cr 13	Z 20 C 13	420 S 37	X 20 Cr 13	SUS 420 J 1	2303	S42000	
	X 70 CrMo 15	1.4109	1.4109	X 65 CrMo 14	Z 70 D 14			SUS 440 A		S44002	
	X 90 CrMoV 18	1.4112	1.4112	X 90 CrMoV 18	Z 2 CND 18 05	409 S 19	X CrTi 12	SUS 440 B	2327	S44003	
	X 105 CrMo 17	1.4125	1.4125	X 105 CrMo 17	Z 100 CD 17		X 105 CrMo 17	SUS 440 C		S44004	
	X 3 CrNiMoAl 13 8 2	1.4534	1.4534	X 3 CrNiMoAl 13 8 2						S13800	
H12	X 5 CrNiCuNb 16 4	1.4548	1.4542	X 5 CrNiCuNb 17 4	Z 6 CNU 17.4			SCS 24, SUS 630		S17400	
	X 7 CrNiAl 17 7	1.4568	1.4568	X 7 CrNiAl 17 7	Z 9 CAN 17.7	301 S 81	X 7 CrNiAl 17 7	SUS 631	2388	S17700	
	X 6 NiCrTiMoV 25 15	1.4980	1.4943	X 4 NiCrTi 25 15	Z 6 NCTDV 25.15	HR 51		SUH 660	2570	S66286	
	X 120 Mn 12	1.3401	1.3401	X 120 Mn 12	Z 120 M 12	BW 10		SC MnH 1	2183		
H31	EN-GJN-HV520	0.9620	G-X330 NiCr 4 2	FB Ni4 Cr2 BC	Grade 2 A	Grade 2 A			05 12-00	F45001	
	EN-GJN-HV550	0.9625	G-X260 NiCr 4 2	FB Ni4 Cr2 HC	Grade 2 B	Grade 2 B			05 13-00	F45000	
	EN-GJN-HV600(XCr11)	0.9630	G-X300 CrNiSi 9 5 2	FB Cr9 Ni5	Grade 2 C, D, E	Grade 2 C, D, E			04 57-00	F45003	

SMG

U.N.E./I.H.A.	AISI / ASTM	GOST	Misc. Brands	Condition	Structure
			Discolloy	Precipitation hardened	
			Haynes 25		
			Stellite 21		
			Stellite 31		
			Hastelloy C		
		KHN65MV	Hastelloy C-276		
			IN 100		
			Inconel 718		
			Inconel X-750	Solution treated	
			Nimonic 80A		
			René 41		
			Udimet 500		
			Waspalloy		
			Ti	Commercially pure	Ti (α)
	AMS 4919		Ti 6-2-4-2	Annealed	Ti (α)
	AMS 4943		Ti 3Al-2.5V (grd 9)	Annealed	Ti (α + β)
	AMS 4920, Grd 5	VT6	Ti 6Al-4V	Annealed	Ti (α + β)
	AMS 4986		Ti 10V-2Fe-3Al	Annealed	Ti (β)
F.1516	5115	12KHN2		Case hardened	
F.1252	4142, 4140	38HM		Quenched & Tempered	
F.5103	1070	70		Quenched & Tempered	
F.5107	1078, 1080	75		Quenched & Tempered	
F.5117	1095			Quenched & Tempered	
F.5118	W 1	U10A		Quenched & Tempered	
	S1	5KHV2SF		Quenched & Tempered	
	5155			Quenched & Tempered	
F.520L	L2	11KHF		Quenched & Tempered	
F.5220	O1	9KHVG		Quenched & Tempered	
	O2	9G2F		Quenched & Tempered	
F.5230	52100	SHKH15		Quenched & Tempered	
F.5318	H13	4KH5MF1S		Quenched & Tempered	
F.5227	A2	9KH5VF		Quenched & Tempered	
F.5211	D2	KH12MF		Quenched & Tempered	
F.5213		KH12		Quenched & Tempered	
		KH12MF		Quenched & Tempered	
F.520.S	L6	5KHNM		Quenched & Tempered	
F.5613	M35	R6M5K5		Quenched & Tempered	
	M42	R2AM9K5		Quenched & Tempered	
F.5603	M2	R6M5		Quenched & Tempered	
	T1	R18		Quenched & Tempered	
F.5261	420	20KH13		Quenched & Tempered	Martensite
	440 A			Quenched & Tempered	Martensite
	440 B	95KH18		Quenched & Tempered	Martensite
	440 C	95KH18		Quenched & Tempered	Martensite
	XM-13		PH13-8Mo	Precipitation hardened	Martensite
	630		17-4-PH	Precipitation hardened	Martensite
	AMS 5528	09KH17N7YU1	17-7-PH	Precipitation hardened	Austenite/ferrite
	660		A286	Precipitation hardened	Austenite
	A128 Grade A				
	A532 IB (NiCr-LC)		Ni-Hard 2		White cast iron
	A532 IA (NiCr-HC)		Ni-Hard 1		White cast iron
	A532 ID (Ni-HiCr)		Ni-Hard 4		White cast iron

Cemented carbide inserts and insert carriers

Cemented carbide inserts and cemented carbide insert carriers from Seco Tools are not included in the product range intended for the following requirements. Nevertheless Seco Tools can make the following declaration.

These products meet all requirements in RoHS (Restriction of the use of certain Hazardous Substances in electrical and electronic equipment), WEEE (Waste Electrical & Electronic Equipment) and ELV (End of Life Vehicles) requirements.

Products do not contain mercury, lead, hexavalent chromium, cadmium, CFC, HCFC, flame retardants or solvents in concentrations that exceed specifications in the regulations.

Regrinding:

Wet or dry grinding can produce potentially hazardous dusts or mists that can irritate skin, eyes, nose, throat and result in lung damage or disease. To avoid injury use proper safety precautions and protective equipment.

Disposal:

Seco Tools will buy back used inserts and solid carbide tools for recycling. Inserts and solid carbide tools should be separated from other metal waste (steel, aluminium, copper etc).

All packing material is fully recyclable.

CBN and PCD inserts

Inserts from Seco Tools are not included in the product range intended for the following requirements. Nevertheless Seco Tools can make the following declaration.

This product meets all requirements in RoHS (Restriction of the use of certain Hazardous Substances in electrical and electronic equipment), WEEE (Waste Electrical & Electronic Equipment) and ELV (End of Life Vehicles) requirements.

Products do not contain mercury, lead, hexavalent chromium, cadmium, CFC, HCFC, flame retardants or solvents in concentrations that exceed specifications in the regulations.

Regrinding:

Wet or dry grinding can produce potentially hazardous dusts or mists that can irritate skin, eyes, nose, throat and result in lung damage or disease. To avoid injury use proper safety precautions and protective equipment.

Disposal:

Seco Tools will buy back used CBN- or PCD-tipped inserts for recycling. Inserts should be separated from other metal waste (steel, aluminium, copper etc). Solid CBN-inserts may be discarded as landfill waste.

All packing material is fully recyclable.

Black oxide insert carriers

Insert carriers from Seco Tools are not included in the product range intended for the following requirements. Nevertheless Seco Tools can make the following declaration.

This product meets all requirements in RoHS (Restriction of the use of certain Hazardous Substances in electrical and electronic equipment), WEEE (Waste Electrical & Electronic Equipment) and ELV (End of Life Vehicles) requirements.

Products do not contain mercury, lead, hexavalent chromium, cadmium, CFC, HCFC, flame retardants or solvents in concentrations that exceed specifications in the regulations.

Disposal:

Used insert carriers may be sent for recycling together with ordinary steel waste (swarf and discarded steel scrap) for recycling.

All packing material is fully recyclable.

Cermet inserts

Inserts from Seco Tools are not included in the product range intended for the following requirements. Nevertheless Seco Tools can make the following declaration.

This product meets all requirements in RoHS (Restriction of the use of certain Hazardous Substances in electrical and electronic equipment), WEEE (Waste Electrical & Electronic Equipment) and ELV (End of Life Vehicles) requirements.

Cermet grade C15M inserts do contain nickel and will leach nickel when in contact with the skin. Amount of leaching is higher than specified in norm SS-EN 1811 Reference test method for release of nickel from products intended to come into direct and prolonged contact with the skin. These norms are intended for products that are in direct and prolonged contact with the skin and are therefore not directly applicable for cermet inserts. Persons with known allergic reactions to nickel are advised to wear protective gloves when handling cermet inserts.

Regrinding:

Wet or dry grinding can produce potentially hazardous dusts or mists that can irritate skin, eyes, nose, throat and result in lung damage or disease. To avoid injury use proper safety precautions and protective equipment.

Disposal:

Used inserts may be recycled. Inserts should be separated from other metal waste (steel, aluminium, copper, etc) including cemented carbide inserts.

All packing material is fully recyclable.

Nickel coated insert carriers

Insert carriers from Seco Tools are not included in the product range intended for the following requirements. Nevertheless Seco Tools can make the following declaration.

This product meets all requirements in RoHS (Restriction of the use of certain Hazardous Substances in electrical and electronic equipment), WEEE (Waste Electrical & Electronic Equipment) and ELV (End of Life Vehicles) requirements.

Products do not contain mercury, lead, hexavalent chromium, cadmium, CFC, HCFC, flame retardants or solvents in concentrations that exceed specifications in the regulations.

Insert carriers do contain nickel and will leach nickel when in contact with the skin. Amount of leaching is not higher than norm SS-EN 1811 Reference test method for release of nickel from products intended to come into direct and prolonged contact with the skin.

These norms are intended for products that are in direct and prolonged contact with the skin and are therefore not directly applicable for insert carriers. Persons with known allergic reactions to nickel are advised to wear protective gloves when handling nickel coated insert carriers.

Disposal:

Used tools maybe sent for recycling together with ordinary steel waste (swarf and discarded steel scrap) for recycling.

All packing material is fully recyclable.

Intentionally added alloying elements

Grade	Cemented carbide										Coating						
	W	Ti	Ta	Nb	Co	Cr	Ni	Mo	C	N	Ti	Al	C	N	O	Si	Nb
CP20	■				■				■		■			■			
CP200	■				■	■			■		■	■		■			
CP300	■	■	■	■	■				■		■	■		■			
CP500	■				■	■			■		■	■		■			
CP600	■				■	■			■		■	■		■			
C15M	■	■	■	■	■		■	■	■	■							
CF	■		■		■		■	■	■								
CM	■		■		■		■	■	■								
DP2000	■		■	■	■				■		■	■	■	■	■		
DP3000	■	■	■	■	■				■	■	■	■	■	■	■		
F15M	■				■	■			■		■	■		■			
F25M	■	■	■	■	■				■		■	■		■			
F30M	■				■	■			■		■	■		■			
F40M	■				■	■			■		■	■		■			
HX	■		■		■				■								
H02	■		■		■	■			■								
H15	■				■	■			■								
H25	■				■	■			■								
KX	■				■	■			■								
MH1000	■				■	■			■		■	■		■			
MK1500	■		■		■				■		■	■	■	■	■		
MK2050	■		■		■	■			■		■	■	■	■		■	
MM4500	■				■	■			■		■	■	■	■	■		
MP1020	■	■		■	■				■		■	■	■	■	■		
MP1500	■		■	■	■				■		■	■	■	■	■		
MP2500	■		■	■	■				■		■	■	■	■	■		
MP3000	■				■	■			■		■	■	■	■	■		
MS2500	■		■	■	■				■		■	■	■	■	■		
MS2050	■				■	■			■		■	■	■	■	■		■
RX1500	■		■		■		■	■	■		■	■	■	■	■		
RX2000	■		■		■	■			■		■	■	■	■	■		
T350M	■		■	■	■				■		■	■	■	■	■		
T25M	■		■	■	■				■		■	■	■	■	■		
TGK1500	■		■		■				■		■	■	■	■	■		
TGP25	■	■	■	■	■				■		■	■	■	■	■		
TGP35	■		■	■	■				■		■	■	■	■	■		
TGP45	■		■	■	■				■		■	■	■	■	■		
TH1000	■				■	■			■		■	■	■	■	■		■
TH1500	■				■	■			■		■	■	■	■	■		
TK1001	■				■	■			■		■	■	■	■	■		
TK2001	■		■		■	■			■		■	■	■	■	■		
TM2000	■	■	■	■	■				■	■	■	■	■	■	■		
TM4000	■	■	■	■	■				■	■	■	■	■	■	■		
TP0500	■	■	■	■	■				■		■	■	■	■	■		
TP0501	■	■	■	■	■	■			■		■	■	■	■	■		
TP1020	■	■	■	■	■				■	■	■	■	■	■	■		
TP1030	■	■	■	■	■				■	■	■	■	■	■	■		■
TP1500	■	■	■	■	■				■	■	■	■	■	■	■		
TP1501	■	■	■	■	■				■	■	■	■	■	■	■		
TP200	■	■	■	■	■				■	■	■	■	■	■	■		
TP2500	■	■	■	■	■				■	■	■	■	■	■	■		
TP2501	■	■	■	■	■	■			■	■	■	■	■	■	■		
TP40	■		■	■	■				■		■	■	■	■	■		
TS2000	■				■	■			■		■	■	■	■	■		
TS2500	■		■		■				■		■	■	■	■	■		
T250D	■				■	■			■		■	■	■	■	■		
T400D	■				■	■			■		■	■	■	■	■		
T100R	■		■		■	■			■		■	■	■	■	■		
T60M	■	■	■	■	■				■		■	■	■	■	■		
883	■		■		■				■								
890	■				■	■			■								